

# CRIMP ATTACHMENTS FOR FLEXIBLE AND SEMI-RIGID CABLE

For Cable Group Legend, see page 19

MCX COAXIAL CONNECTORS

## RIGHT ANGLE CRIMP PLUG — FLEXIBLE CABLE

P.N.	Cable Group	Finish	Insulation	Impedance	Crimp Tool
252114	01	Nickel	Teflon	50	A
252115	01	Gold	Teflon	50	A
252122	01A	Nickel	Teflon	50	A
252123	01A	Gold	Teflon	50	A
252100	05	Nickel	Teflon	50	B
252102	05	Gold	Teflon	50	B
252118	05A	Nickel	Teflon	50	C
252119	05A	Gold	Teflon	50	C
252100-75	06	Nickel	Teflon	75	B
252102-75	06	Gold	Teflon	75	B
252118-75	06A	Nickel	Teflon	75	C
252119-75	06A	Gold	Teflon	75	C
252134	14	Nickel	Teflon	50	B
252135	14	Gold	Teflon	50	B

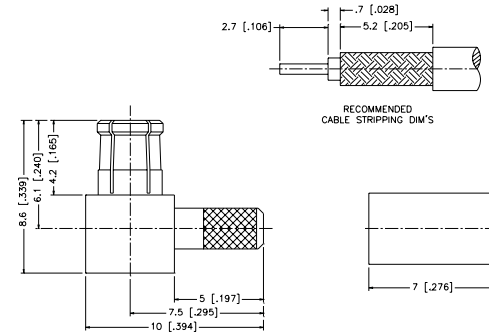
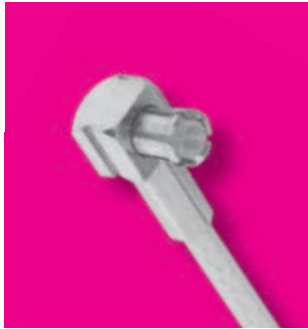

## RIGHT ANGLE SOLDER PLUG — SEMI-RIGID CABLE

P.N.	Cable Group	Finish	Insulation	Impedance	Crimp Tool
252112	10	Nickel	Teflon	50	N/A
252113	10	Gold	Teflon	50	N/A
252108	11	Nickel	Teflon	50	N/A
252109	11	Gold	Teflon	50	N/A
252158	13	Gold	Teflon	50	N/A

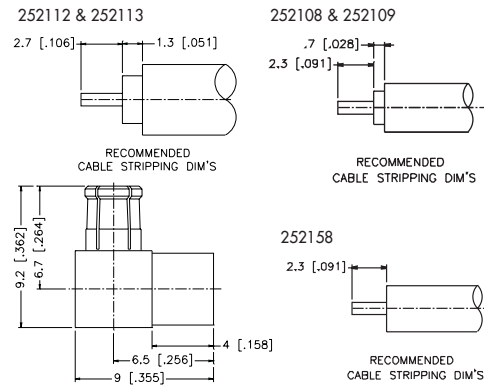
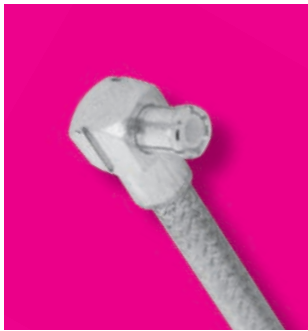

## STRAIGHT CRIMP JACK — FLEXIBLE CABLE

P.N.	Cable Group	Finish	Insulation	Impedance	Crimp Tool
252138	05	Nickel	Teflon	50	B
252139	05	Gold	Teflon	50	B
252164	05A	Nickel	Teflon	50	C
252165	05A	Gold	Teflon	50	C
252136	14	Nickel	Teflon	50	B
252137	14	Gold	Teflon	50	B
252138-75	06	Nickel	Teflon	75	B
252139-75	06	Gold	Teflon	75	B
252164-75	06A	Nickel	Teflon	75	C
252165-75	06A	Gold	Teflon	75	C

