



**SANYO Semiconductors**

# DATA SHEET

An ON Semiconductor Company

## LV24020LP — Bi-CMOS IC Ultra-compact FM tuner IC for mobile set

### Overview

The LV24020LP is FM tuner IC's that requires absolutely no external components.

They incorporates not only the FM tuner functions as well in a compact VQLP package with dimensions of only 5mm×5mm×0.8mm.

These IC's are simply ideal for incorporating FM tuner functions into mobile phones and other small mobile set where space is always at a premium.

### Functions

- FM FE
- FM IF
- MPX Stereo Decoder
- Tuning

### Features

- No external components
- No alignments necessary
- Fully integrated low IF selectivity and demodulation
- Built in adjacent channel interference total reduction (no 114kHz, no 190kHz)
- Due to new tuning concept, the tuning is independent of the channel spacing
- Very high sensitivity due to integrated low noise RF input amplifier
- Very low power Standby mode. No power switch circuitry required
- MPX output for RDS application
- 3-wire bus interface (Data, Clock, NR-W)
- Digital AFC - Tuner locks to frequency after tuning sequence
- 8 level programmable Soft Mute
- 8 level programmable Stereo Blend
- In combination with the host, fast, low power operation of preset mode, manual search, automatic search and automatic preset store are possible
- Covers all Japanese, European and US bands

■ Any and all SANYO Semiconductor Co.,Ltd. products described or contained herein are, with regard to "standard application", intended for the use as general electronics equipment. The products mentioned herein shall not be intended for use for any "special application" (medical equipment whose purpose is to sustain life, aerospace instrument, nuclear control device, burning appliances, transportation machine, traffic signal system, safety equipment etc.) that shall require extremely high level of reliability and can directly threaten human lives in case of failure or malfunction of the product or may cause harm to human bodies, nor shall they grant any guarantee thereof. If you should intend to use our products for new introduction or other application different from current conditions on the usage of automotive device, communication device, office equipment, industrial equipment etc. , please consult with us about usage condition (temperature, operation time etc.) prior to the intended use. If there is no consultation or inquiry before the intended use, our customer shall be solely responsible for the use.

■ Specifications of any and all SANYO Semiconductor Co.,Ltd. products described or contained herein stipulate the performance, characteristics, and functions of the described products in the independent state, and are not guarantees of the performance, characteristics, and functions of the described products as mounted in the customer's products or equipment. To verify symptoms and states that cannot be evaluated in an independent device, the customer should always evaluate and test devices mounted in the customer's products or equipment.

# LV24020LP

## Specifications

### Maximum Ratings at Ta = 25°C

Parameter	Symbol	Conditions	Ratings	Unit
Maximum supply voltage	V <sub>CC</sub> max	Analog block supply voltage	6.0	V
	V <sub>DD</sub> max	Digital block supply voltage	5.0	V
Digital input voltage	V <sub>IN1</sub> max	Clock, Data, NR_W	V <sub>DD</sub> +0.3	V
	V <sub>IN2</sub> max	External_clk_in	V <sub>DD</sub> +0.3	V
Allowable power dissipation	P <sub>d</sub> max	Ta ≤ 70°C	140	mW
Operating temperature	T <sub>opr</sub>		-20 to +70	°C
Storage temperature	T <sub>stg</sub>		-40 to +125	°C

### Operating Condition at Ta = 25°C

Parameter	Symbol	Conditions	Ratings	Unit
Recommended supply voltage	V <sub>CC</sub>	Analog block supply voltage	3.0	V
	V <sub>DD</sub>	Digital block supply voltage	3.0	V
Operating supply voltage range	V <sub>CC</sub> op		2.7 to 5.0	V
	V <sub>DD</sub> op		2.5 to 4.0	V
	V <sub>IO</sub> op	Interface supply voltage	1.8 to 4.0	V

Note: Power supply voltage V<sub>IO</sub> equal V<sub>DD</sub>, or V<sub>IO</sub> < V<sub>DD</sub> (V<sub>IO</sub> ≤ V<sub>DD</sub>)

### Interface Conditions at Ta = -20 to +70°C, V<sub>SS</sub> = 0V

Parameter	Symbol	Conditions	Ratings			Unit
			min	typ	max	
Supply voltage	V <sub>DD</sub>		2.5		4.0	V
Digital part input	V <sub>IH</sub>	High level input voltage range	0.7V <sub>DD</sub>		V <sub>DD</sub>	V
	V <sub>IL</sub>	Low level input voltage range	0		0.6	V
Digital part output	I <sub>OL</sub>	Low level output current	2.0			mA
	V <sub>OL</sub>	Low level output voltage I <sub>OL</sub> =2mA			0.6	V
Clock input frequency	f <sub>clk</sub>	3wire_bus (29pin) clock frequency			0.7	MHz
External clock frequency	f <sub>clk_ext</sub>	CLK_IN (31pin) frequency	32k		14M	Hz

Note: CLK\_IN (31pin) can input sign wave.

## LV24020LP

**Operating Characteristics** at Ta = 25°C, VCC=3.0V, VDD=3.0V, VOL=14, Soft Mute/Stereo=off

VOL=14 –Block2 register09h Volume\_Bit 3-0 = 0010

Parameter	Symbol	Conditions	Ratings			Unit
			min	typ	max	
Operational supply current	ICCA	Analog Block at 60dB $\mu$ input The 23pin is measured		14	17	mA
	ICCD	Digital Block at 60dB $\mu$ input The 27, 40 pins are measured.	0.2	0.4	0.8	mA
Standby supply current	ICCA	Analog standby mode The 23 pin is measured.		3	30	$\mu$ A
	ICCD	Digital standby mode The 27, 40 pins are measured.		3	30	$\mu$ A
FM coverd frq	F_range		76		108	MHz
[FM receiving characteristics ; MONO]: fc=80MHz, fm=1kHz, 22.5kHzdev. soft_stereo, soft_mute, Buss, Treble are all OFF.						
Input limiting voltage	-3dB LS	V <sub>IN</sub> =60dB $\mu$ standard for a -3dB input		13	19	dB $\mu$ V EMF
Practical sensitivity	QS1	for 30dB signal to noise ratio input De-emphasis is 75 $\mu$ s SG open		10	16	dB $\mu$ V EMF
Practical sensitivity	QS2	for 26dB signal to noise ratio input De-emphasis is 75 $\mu$ s SG close		1.25		$\mu$ V
Demodulator output level	V <sub>O</sub>	V <sub>IN</sub> =60dB $\mu$ , 11pin output level	50	90	130	mV
Channel balance	CB	V <sub>IN</sub> =60dB $\mu$ , ratio of 11pin to 12pin output level	-2	0	2	dB
Signal to noise ratio	S/N	V <sub>IN</sub> =60dB $\mu$ , 11pin output level	48	58		dB
Total harmonic distortion 1 (MONO)	THD1	V <sub>IN</sub> =60dB $\mu$ , 22.5kHzdev, 11pin output		0.4	1.5	%
Total harmonic distortion 2 (MONO)	THD2	V <sub>IN</sub> =60dB $\mu$ , 75kHzdev, 11pin output		1.3	3	%
Field strength level	FS	Input level for FS1 to FS2	8	18	27	dB $\mu$
Muting attenuation	Mute-Att	V <sub>IN</sub> =60dB $\mu$ , 11pin output level	60	70		dB
[FM receiving characteristics ; STEREO]: fc=80MHz, fm=1kHz, V <sub>IN</sub> =60dB $\mu$ V, L+R=30% (22.5kHzdev), Pilot=10% (7.5kHzdev)						
Separation	SEP	L-mod,11pin→12pin output level	20	35		dB
Total harmonic distortion (STEREO)	THD-ST	Main-mod (L+R), 11pin/12pin output, IHF_BPF		0.6	1.8	%

# LV24020LP

## Package Dimensions

unit : mm (typ)

3302A

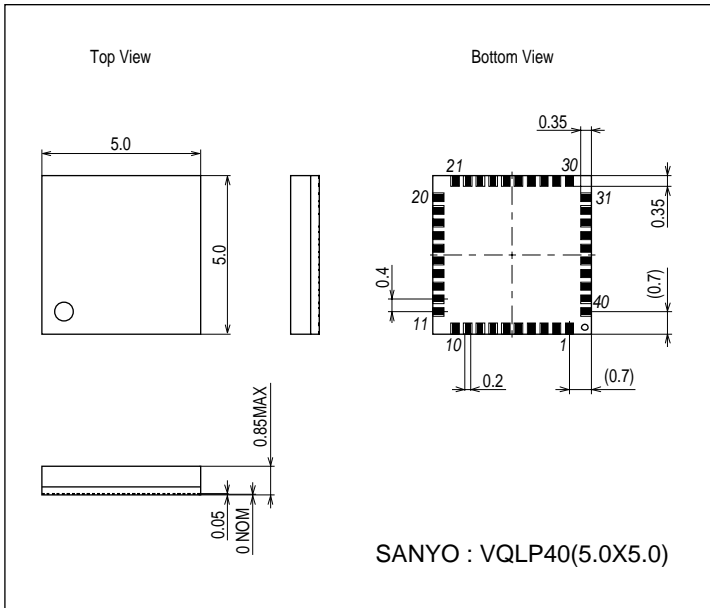

## Pin Assignment

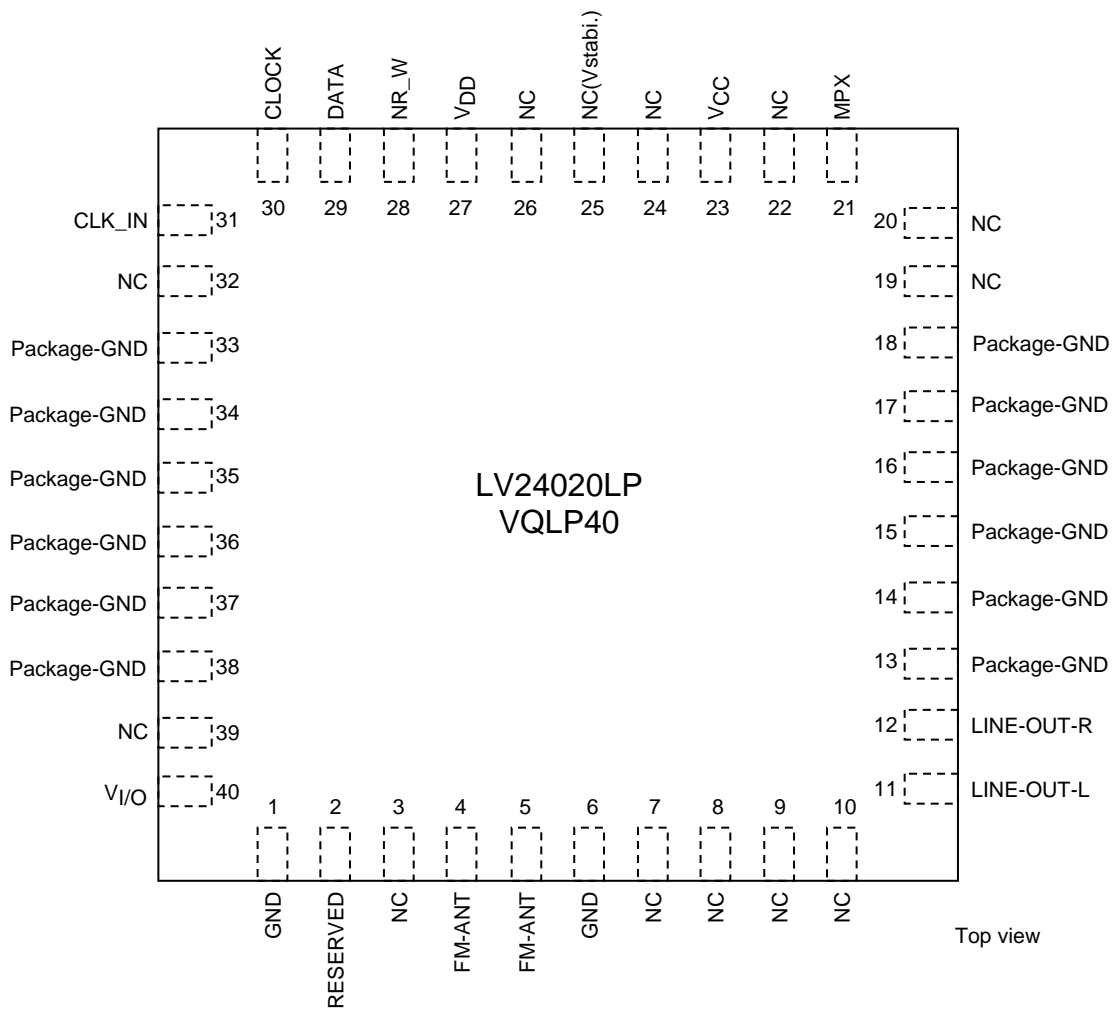

## LV24020LP

### VQLP40 package Pin Description

Pin	LV24020LP	Description	Remark	DC_bias
1	GND	GND (Analog and Digital GND)		
2	RESERVED		Do not connect	
3	NC			
4	FM-ANT1	Antenna input		
5	FM-ANT2	Antenna GND	Connect to GND	
6	GND	GND (Analog and Digital GND)		
7	NC			
8	NC			
9	NC			
10	NC			
11	LINE-OUT-L	Radio Lch Line-output		1.2V
12	LINE-OUT-R	Radio Rch Line-output		1.2V
13	Package-GND	GND for Package-shield		
14	Package-GND	GND for Package-shield		
15	Package-GND	GND for Package-shield		
16	Package-GND	GND for Package-shield		
17	Package-GND	GND for Package-shield		
18	Package-GND	GND for Package-shield		
19	NC			
20	NC			
21	MPX	MPX-signal output		V <sub>CC</sub> -0.3V
22	NC			
23	V <sub>CC</sub>	Analog supply voltage		
24	NC			
25	V <sub>stabi.</sub>	Stabilizer voltage		2.7V
26	NC			
27	V <sub>DD</sub>	Digital supply voltage		
28	NR_W	Digital interface Read/Write		
29	DATA	Digital interface DATA		
30	CLOCK	Digital interface Clock		
31	CLK_IN	Reference clock-source input for measurement	Connect to GND if not used	
32	NC			
33	Package-GND	GND for Package-shield		
34	Package-GND	GND for Package-shield		
35	Package-GND	GND for Package-shield		
36	Package-GND	GND for Package-shield		
37	Package-GND	GND for Package-shield		
38	Package-GND	GND for Package-shield		
39	NC			
40	V <sub>I/O</sub>	Digital interface supply voltage		

# LV24020LP

## Block Diagram

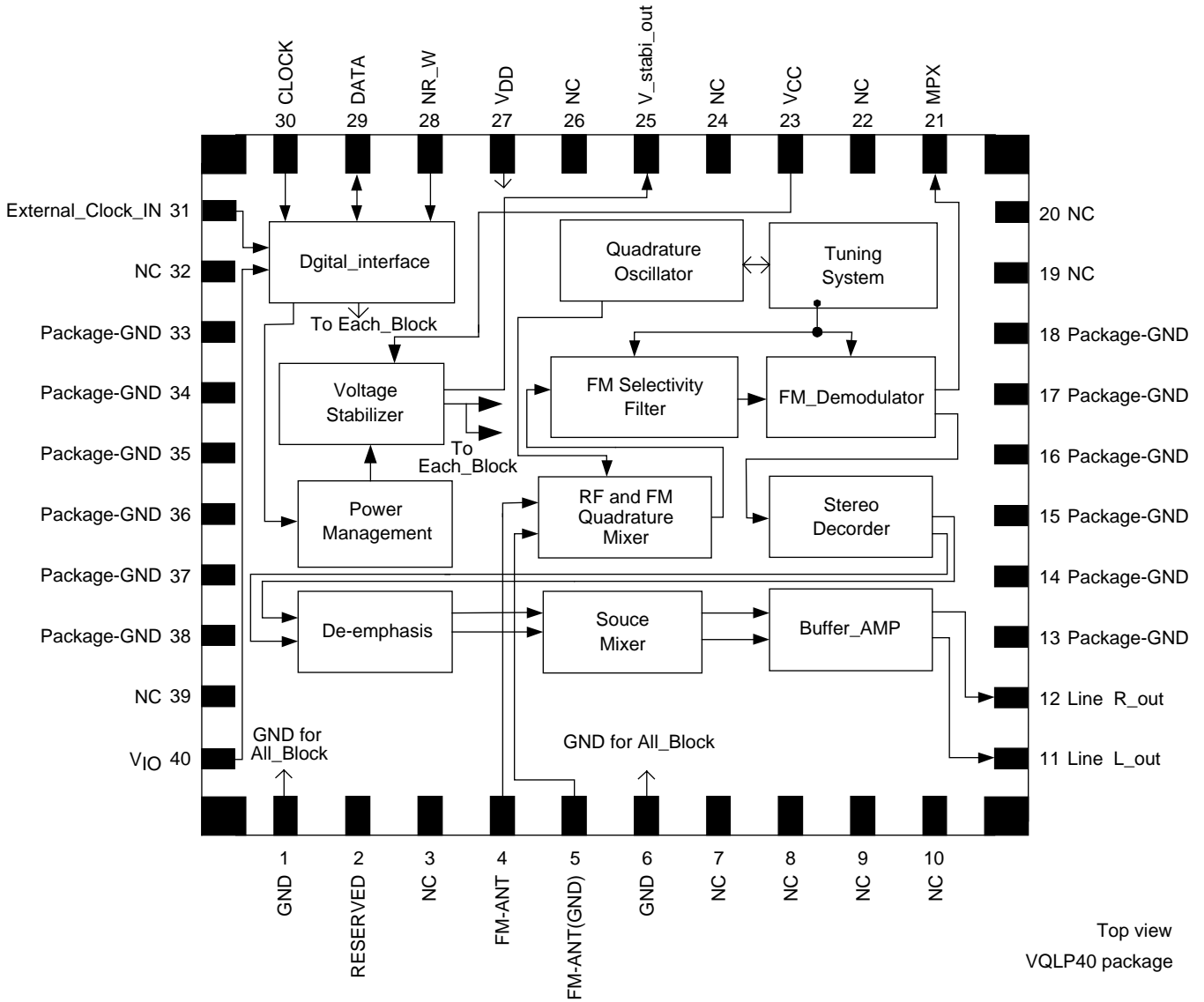

Top view  
VQLP40 package

ILV000223

# LV24020LP

## Measurement Circuit

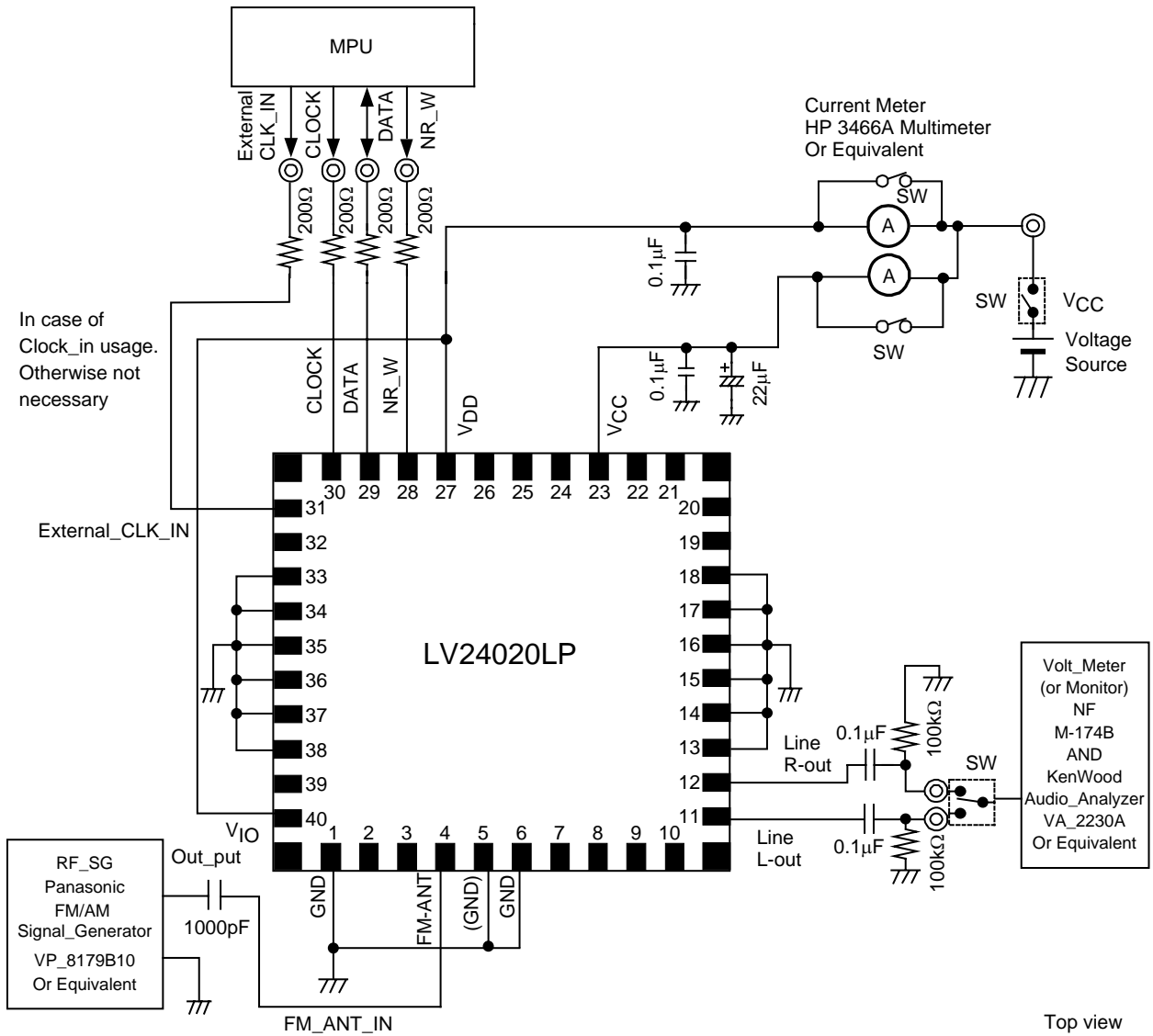

Top view  
VQLP40 package

ILV000224

Application Circuit

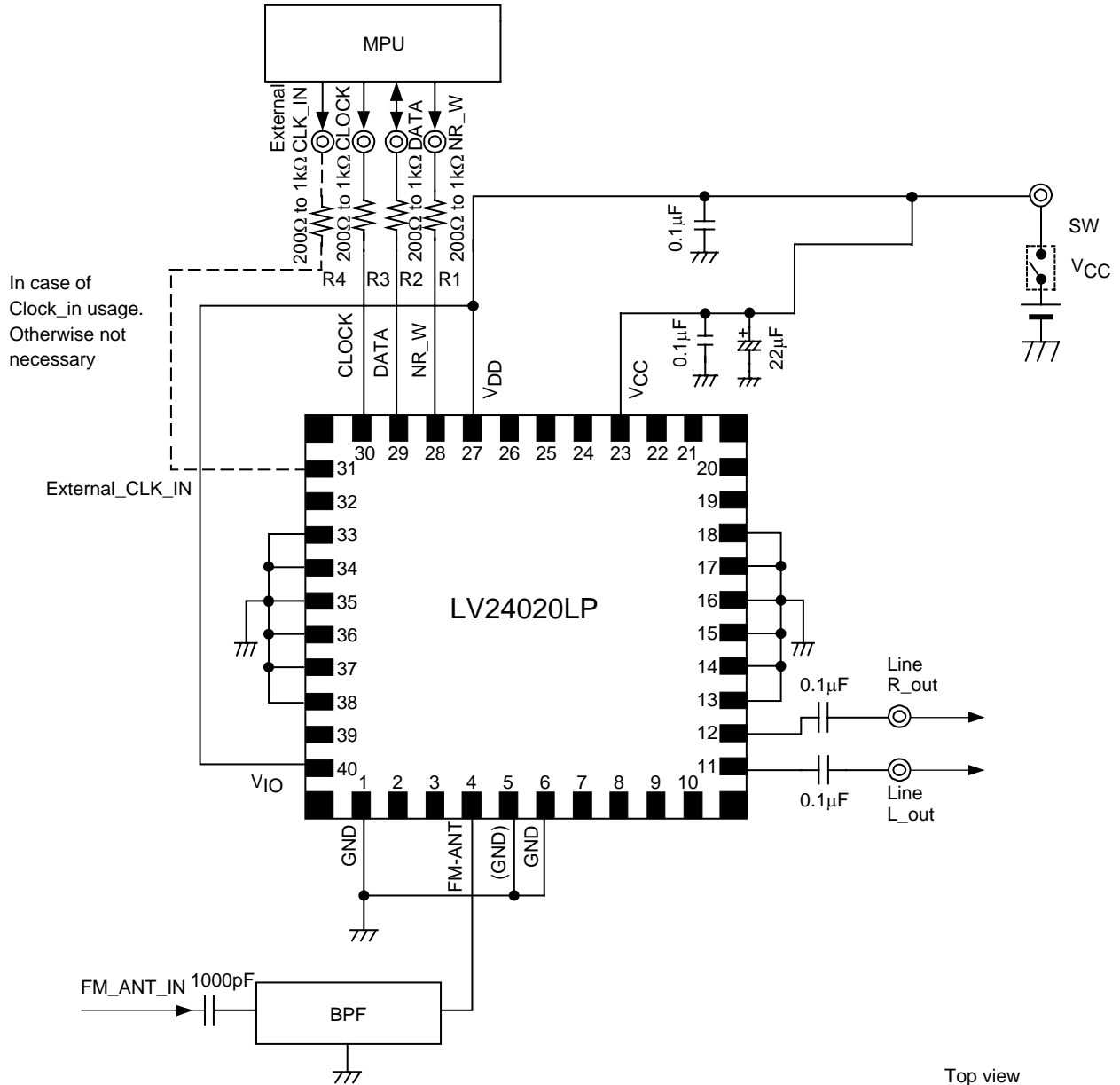

Top view  
VQLP40 package

ILV000225

Note1: Vale of External Component is just reference. Please set most suitable value under Aactual\_operation.

Note2: In case of necessary about BPF for FM\_in, Please take Consideration of most suitable\_value.

Note3: We recommend to put R1, R2, R3, R4 for interface between MPU and IC.

Note4: Please put Capacitor Between V<sub>DD</sub> and GND also, put Capacitor Between V<sub>CC</sub> and GND as shown on application.

- SANYO Semiconductor Co.,Ltd. assumes no responsibility for equipment failures that result from using products at values that exceed, even momentarily, rated values (such as maximum ratings, operating condition ranges, or other parameters) listed in products specifications of any and all SANYO Semiconductor Co.,Ltd. products described or contained herein.
- SANYO Semiconductor Co.,Ltd. strives to supply high-quality high-reliability products, however, any and all semiconductor products fail or malfunction with some probability. It is possible that these probabilistic failures or malfunction could give rise to accidents or events that could endanger human lives, trouble that could give rise to smoke or fire, or accidents that could cause damage to other property. When designing equipment, adopt safety measures so that these kinds of accidents or events cannot occur. Such measures include but are not limited to protective circuits and error prevention circuits for safe design, redundant design, and structural design.
- In the event that any or all SANYO Semiconductor Co.,Ltd. products described or contained herein are controlled under any of applicable local export control laws and regulations, such products may require the export license from the authorities concerned in accordance with the above law.
- No part of this publication may be reproduced or transmitted in any form or by any means, electronic or mechanical, including photocopying and recording, or any information storage or retrieval system, or otherwise, without the prior written consent of SANYO Semiconductor Co.,Ltd.
- Any and all information described or contained herein are subject to change without notice due to product/technology improvement, etc. When designing equipment, refer to the "Delivery Specification" for the SANYO Semiconductor Co.,Ltd. product that you intend to use.
- Upon using the technical information or products described herein, neither warranty nor license shall be granted with regard to intellectual property rights or any other rights of SANYO Semiconductor Co.,Ltd. or any third party. SANYO Semiconductor Co.,Ltd. shall not be liable for any claim or suits with regard to a third party's intellectual property rights which has resulted from the use of the technical information and products mentioned above.

This catalog provides information as of January, 2012. Specifications and information herein are subject to change without notice.