

MALE-MALE ADAPTER SLIDE-SNAP TYPE
BOARD TO BOARD 10MM

R223.703.050

Series : MMBX

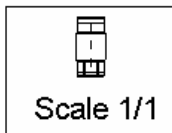
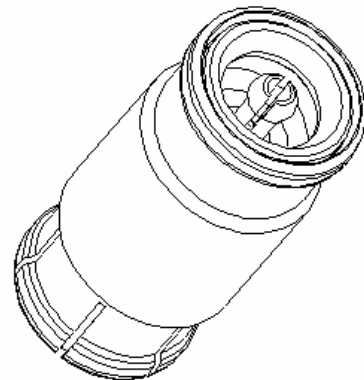
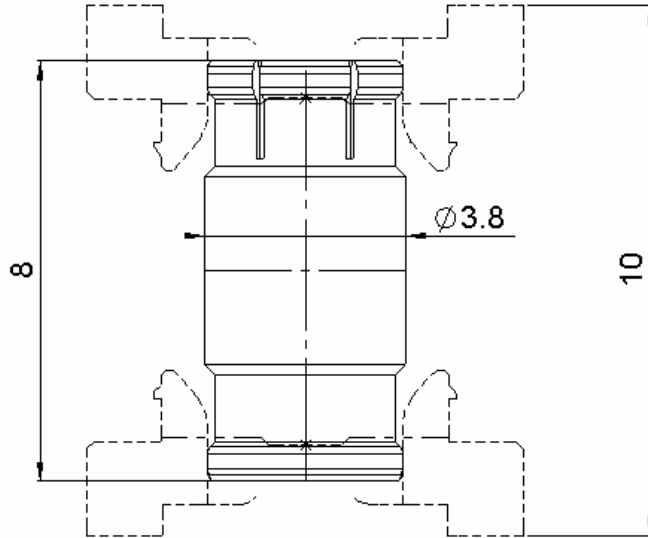

All dimensions are in mm.

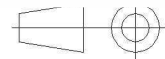

COMPONENTS	MATERIALS	PLATING (µm)
BODY	BRONZE	NPGR
CENTER CONTACT	BERYLLIUM COPPER	NPGR
OUTER CONTACT	-	-
INSULATOR	PTFE	
GASKET		
OTHERS PARTS		
-	-	-
-	-	-

Issue : 0906 C

In the effort to improve our products, we reserve the right to make changes judged to be necessary.



MALE-MALE ADAPTER SLIDE-SNAP TYPE

R223.703.050

BOARD TO BOARD 10MM

Series : MMBX

PACKAGING

SPECIFICATION

Standard	Unit	Other
100	'W' option	Contact us

ELECTRICAL CHARACTERISTICS

ENVIRONMENTAL

Impedance	50	Ω
Frequency	0-12.4	GHz
VSWR	1.083* + 0.0000	x F(GHz) Maxi
Insertion loss	TBD	\sqrt{F} (GHz) dB Maxi
RF leakage	- (100**)	- F(GHz)) dB Maxi
Voltage rating	330	Veff Maxi
Dielectric withstanding voltage	500	Veff mini
Insulation resistance	1000	M Ω mini

Operating temperature	-55/+155	$^{\circ}$ C
Hermetic seal	NA	Atm.cm3/s
Panel leakage	NA	

OTHER CHARACTERISTICS

Assembly instruction

Others :

* to 6 GHz

** Interface MMBX only, up to 2.5 GHz

PCB to PCB -50 dB up to 2.5 GHz

MECHANICAL CHARACTERISTICS

Center contact retention		
Axial force – Mating end	10	N mini
Axial force – Opposite end	10	N mini
Torque	NA	N.cm mini
Recommended torque		
Mating	NA	N.cm
Panel nut	NA	N.cm
Mating life	100	Cycles mini
Weight	0.2970	g

Issue : 0906 C

In the effort to improve our products, we reserve the right to make changes judged to be necessary.

RADIALL 