

| Photo Stem color : Ivory | Dimensions | Mounting Hole Dimensions | Circuit Diagram |
 | Packing Specifications | Soldering Conditions | Products Line of Knob |

PRINT

Top push type

Part number	SKEGACA010	
Type	Snap-in	
Operating force	0.78N	
Operating direction	Top push	
Travel	1mm	
Operating life (1mA 5V DC)	100,000 cycles	
Initial contact resistance	1kΩ max.	
Stem color	Ivory	
Stem	Joint stem	
Series type	Soft feeling type	
Operating temperature range	-20°C to +70°C	
Rating (max.)	5mA 12V DC	
Rating (min.)	10μA 1V DC	
Electrical performance	Insulation resistance	100MΩ min. 100V DC for 1min.
	Voltage proof	250V AC for 1 min.
Durability	Vibration	10 to 55 to 10Hz/min., the amplitude is 1.5mm for all the frequencies, in the 3 direction of X, Y and Z for 2 hours respectively
Environmental performance	Cold	-30±2°C for 96h
	Dry heat	80±2°C for 96h
	Damp heat	60±2°C, 90 to 95%RH for 96h
Minimum order unit (pcs.)	Japan	1,000
	Export	1,000



Photo Stem color : Ivory

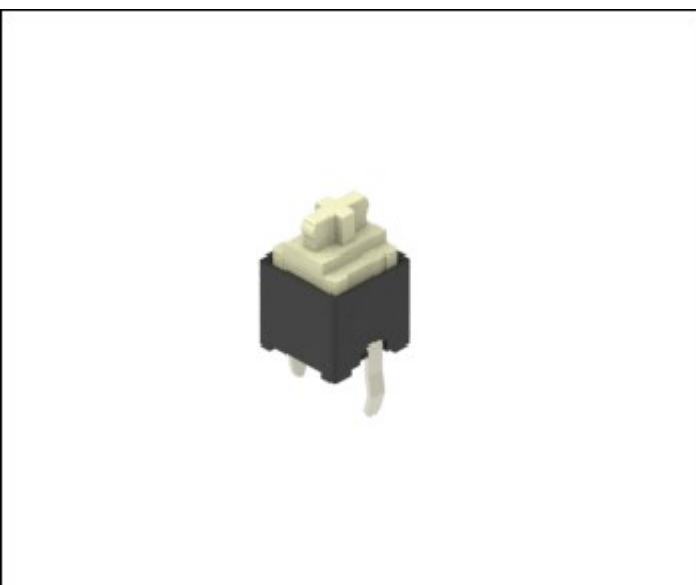

Dimensions

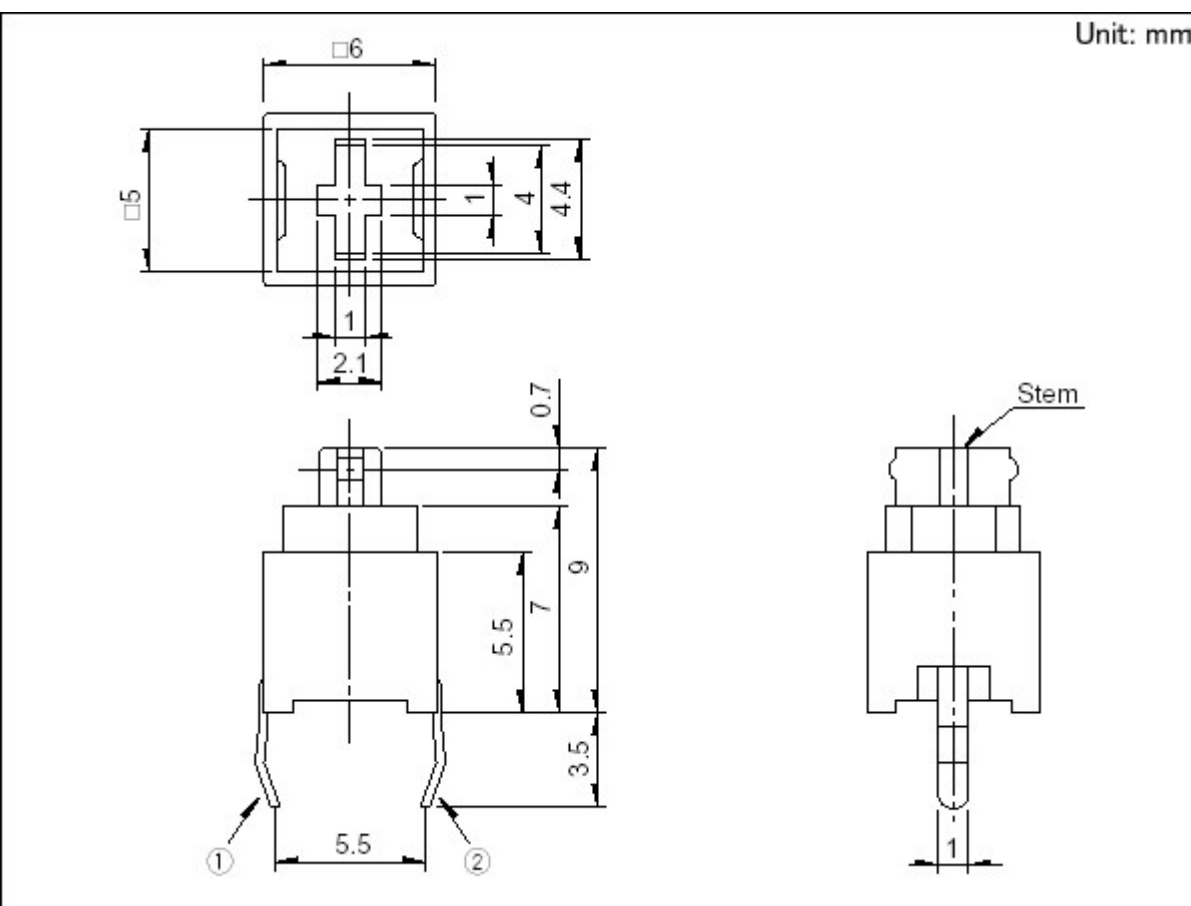

Mounting Hole Dimensions



2- ϕ 1.25 holes

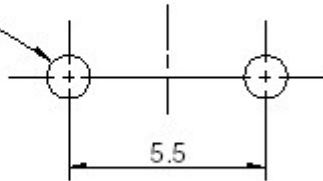

Viewed from mounting face.

Circuit Diagram

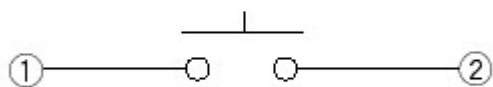

Packing Specifications

Bulk

Number of packages 1 case / Japan 10,000
(pcs.)

1 case / export
packing 30,000

Export package measurements (mm) 309×476×347

Soldering Conditions

Conditions for Auto-dip

Items	Condition
Flux built-up	Mounting surface should not be exposed to flux
Preheating temperature	Ambient temperature of the soldered surface of PC board. 100°C max.
Preheating time	45s max.
Soldering temperature	255°C max.
Duration of immersion	5s max.
Number of soldering	2 times max.

Manual Soldering

Items	Condition
Soldering temperature	350°C max.
Duration of soldering	3s max.
Capacity of soldering iron	20W max.

1. Consult with us for availability of TACT switch™ washing.
2. Prevent flux penetration from the top side of the TACT switch™.
3. Switch terminals and a PC board should not be coated with flux prior to soldering.
4. The second soldering should be done after the switch returns to normal temperature.
5. Use the flux with a specific gravity of at least 0.81.
(EC-19s-8 by TAMURA Corporation, or their equivalents.)

Products Line of Knob

Dimensions (Unit: mm)

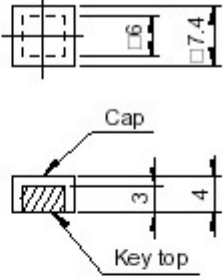
			
		Cap	
Clear	SK2AA00540		
Keytop		Keytop + Cap	
Red	SK2AA00310	SK2AA00360	
Blue	SK2AA00320	SK2AA00370	
Ivory	SK2AA00330	SK2AA00380	
Black	SK2AA00340	SK2AA00390	
Yellow	SK2AA00350	SK2AA00400	

Label dimensions (Unit: mm)

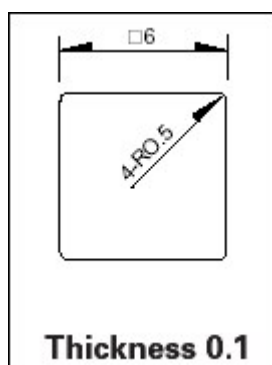

1. The knob will be delivered together with the switch but packed separately.
2. The label is not included.

Notes are common to this series/models.

1. This site catalog shows only outline specifications. When using the products, please obtain formal specifications for supply.

2. Please use 1.6mm thick PC boards. (For horizontal type, 1.0mm)

3. Please place purchase orders per minimum order unit (integer).

4. This products can be used in vehicles.

Although these products are designed to perform over a wide operating temperature range, please ensure that you receive and read the formal delivery specifications before use.

Inquiries about Products

 **Inquiry**