



### Features

- Data rates up to 250 Mbps
- Large-area Si photodiode
- TIA with AGC
- Hermetically sealed package (MIL-STD 883)
- Single 3.3 V power supply

### Applications

- Plastic Optical Fiber (POF) based optical communication links
- IEEE Fast Ethernet
- IEEE 1394b Firewire
- Automotive, Industrial and Residential Networking

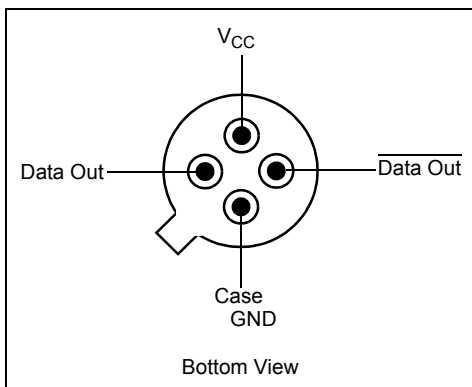

**Figure 1 - Pin-out Diagram**

### Ordering Information

ZL60038TBDE, TO-46 with lens

*The ZL60038 is also available assembled in standard optical receptacles:*

ZL60038TDDE, in ST receptacle  
 ZL60038TEDE, in SC receptacle  
 ZL60038TFDE, in FC receptacle  
 ZL60038TGDE, in SMA receptacle

*In addition the ZL60038 can also be supplied in customer-specific receptacles, on request*

**-40°C to +85°C**

### Description

The ZL60038 is a compact optical receiver designed for 650-nm plastic optical fiber (POF) based optical communication systems with data rates up to 250 Mbps.

The optical receiver is assembled in a single compact TO-46 package and contains an optimized large-area Si PIN photodiode in combination with a transimpedance amplifier (TIA) with automatic gain control (AGC). The receiver operates using a single 3.3 V power supply. It is designed for use with large-core POF with core sizes up to 980 μm. Such optical fiber types are often found in Automotive, Industrial and Residential networks.

Reliability assurance is based on Telcordia GR-468-CORE and the part is compliant to the EU directive 2002/95/EC issued 27 January 2003 [RoHS].

**Optical and Electrical Characteristics**

Parameter	Symbol	Min.	Typ.	Max.	Unit	Test condition
Sensitivity (BER $10^{-12}$ )	S		-24	-22	dBm	ER = $\infty$ Note 1
Optical Saturation (BER $10^{-12}$ )	$P_{sat}$	3			dBm	ER = 10dB, Note 1
Output Voltage amplitude, differential ( $P_{in} = -22$ dBm)	$\Delta V_{OL}$		200		mV, pp	Note 1, See Figure 3
Output Voltage amplitude, differential ( $P_{in} = -3$ dBm)	$\Delta V_{OH}$		500		mV, pp	Note 1, See Figure 3
Bandwidth (3 dB <sub>el</sub> )	$f_C$		160		MHz	$P_{in} = -10$ dBm
Noise-Equivalent Power	NEP		-40		dBm	Note 2
Output Resistance (single-ended)	$R_O$		50		$\Omega$	
Power Supply Current	$I_{DD}$		20	30	mA	
Power Dissipation	$P_D$		70	100	mW	
Focal distance (from top TO-lens)	$L_{focal}$		1.3		mm	

**Test conditions:** Case Temperature, 25°C / Supply Voltage, 3.3V /  $R_L = 1000 \Omega$  differential / Plastic Optical Fiber: 980/1000  $\mu$ m, Step-index N.A. = 0.48 / Wavelength,  $\lambda = 650$  nm

Note 1: Measured using  $2^7-1$  PRBS pattern at 125 Mbps

Note 2: Measured with STM-1 filter on electrical output, i.e., 116 MHz.

**Recommended Operating Conditions**

Parameter	Symbol	Min.	Typ.	Max	Unit
Supply Voltage	$V_{CC}$	3.05		3.55	V
Output Differential Load (Note 3)	$R_L$	80	1000		$\Omega$
Operating Temperature	$T_{op}$	-40		85	°C
Signalling Rate (Note 4)	$f_D$			250	Mbps

Note 3: Typical value corresponds to the load presented by a following post-amplifier

Note 4: Data pattern having maximum run-length and DC-balance shifts no greater than those found in a PRBS-7 pattern.

**Absolute Maximum Ratings**

Functional operation is not guaranteed under these conditions. Exceeding these ratings may cause permanent damage. (Note limits need not necessarily be applied together).

Parameter	Symbol	Min.	Max.	Unit
Supply Voltage	$V_{CC}$	0	4.5	V
Storage Temperature	$T_{stg}$	-55	125	°C
Soldering Temperature (Note 5)	$T_{sld}$		260	°C

Note 5: 2 mm from case for 10 seconds.

Additional Information

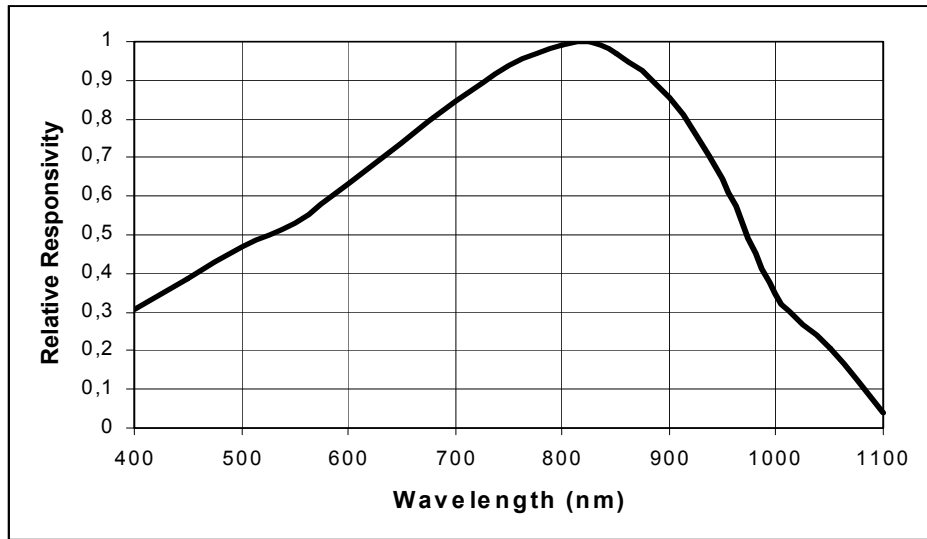

Figure 2 - Relative Responsivity vs. Wavelength

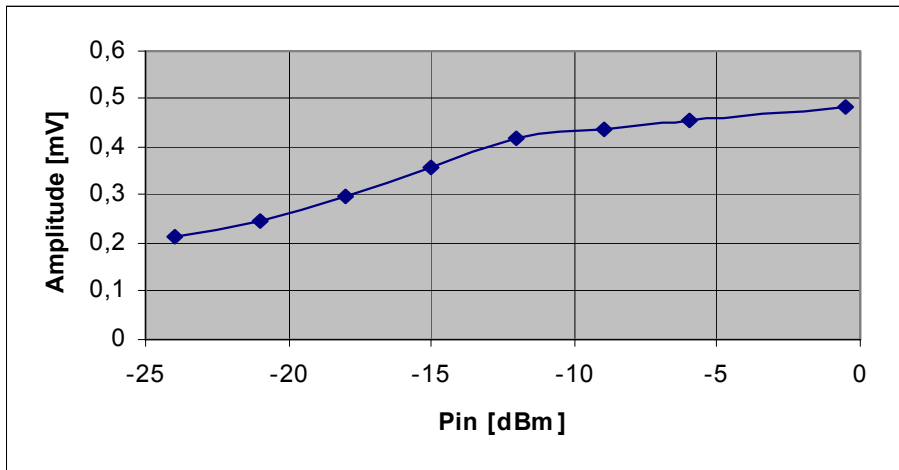

Figure 3 - Differential Output Voltage Amplitude vs. Optical Input Power

## Application Guidelines

### ESD Handling



The receiver is sensitive to electrostatic discharges. When handling the device, precaution for ESD sensitive devices should be taken. These precautions include use of ESD protected work area with wrist straps, controlled work benches, floors etc.

### Host Board Layout Example

Included in the example of a Host Board Layout (Figure 4) are power supply decoupling capacitors. These are recommended for optimal performance of the receiver. A filter is also included to minimise power supply noise.

A recommended post-amplifier is shown, namely Maxim MAX3969. Alternative post-amplifiers may also be used by the customer.

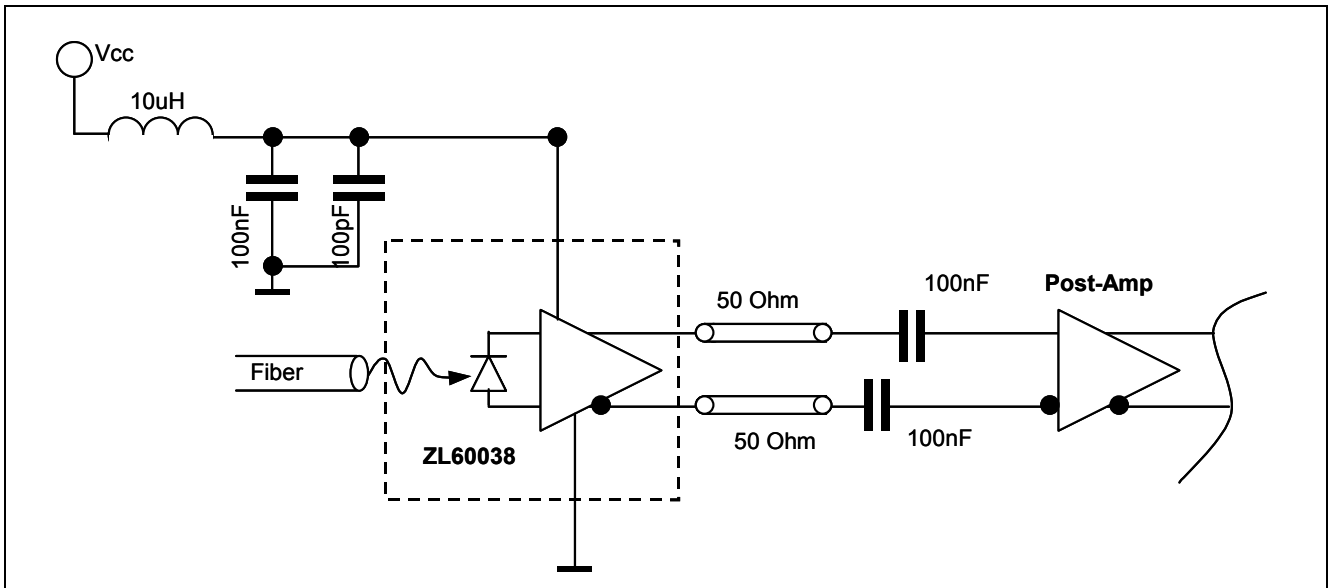
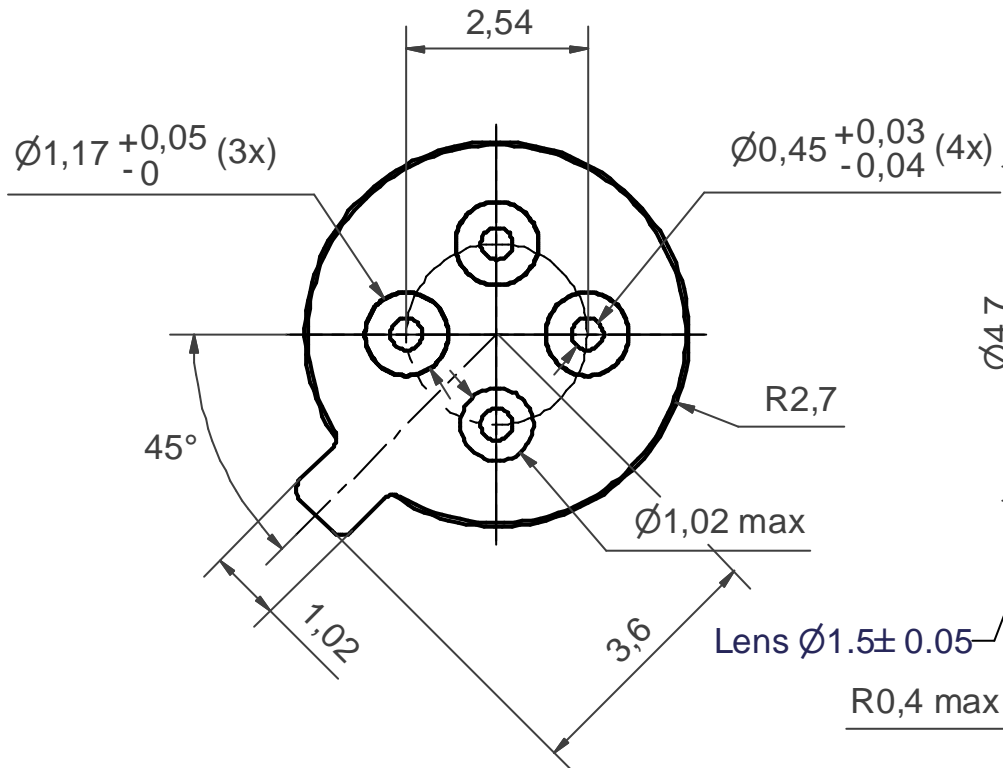
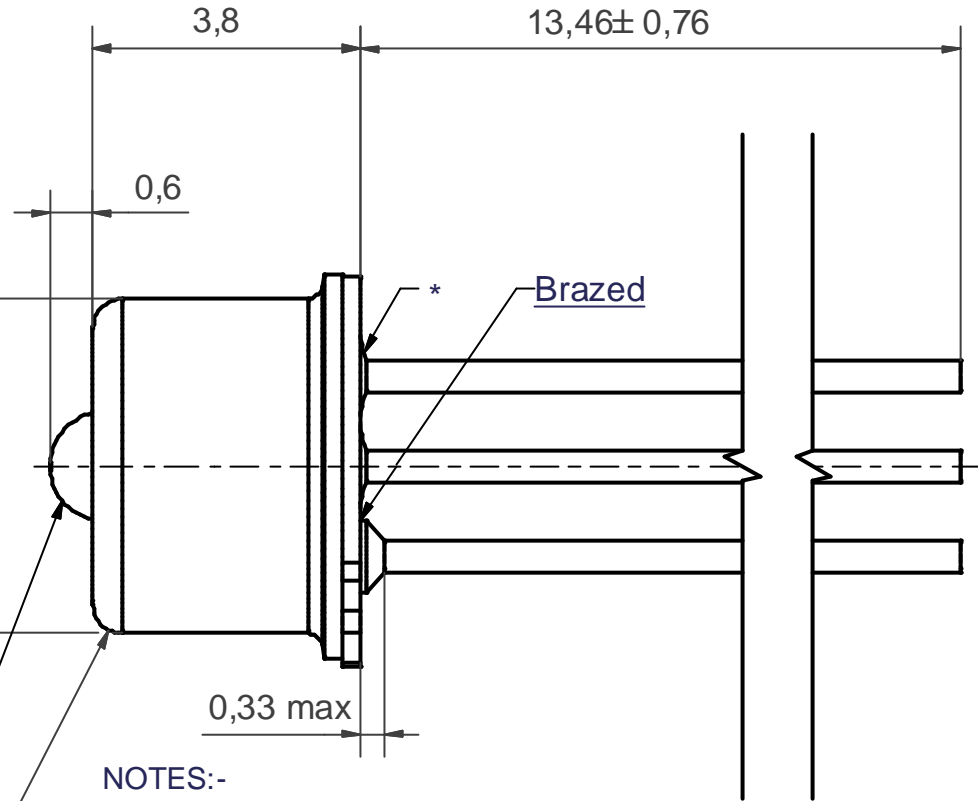

Figure 4 - Host Board Layout Example

# BOTTOM VIEW ( 10 : 1 )



# SIDE VIEW



**NOTES:-**

- 1. All dimensions in mm.
- 2. General tol. ISO-2768-mK.
- 3. Coating: Case: Ni 1,5-2,5  $\mu$ m.  
Header: Ni min 0,5  $\mu$ m / Au min 1,5  $\mu$ m.

\* 0,25 max glass overmould (3x)

© Zarlink Semiconductor 2002. All rights reserved.

ISSUE	1			
ACN	JS004078R1A			
DATE	22-MAR-03			
APPRD.	TD/BE			



	Package code <b>TB</b>
Previous package codes	Drawing type Package drawing, TO-46 with lens
	Title <b>JS004078</b>



**For more information about all Zarlink products  
visit our Web Site at  
[www.zarlink.com](http://www.zarlink.com)**

Information relating to products and services furnished herein by Zarlink Semiconductor Inc. or its subsidiaries (collectively "Zarlink") is believed to be reliable. However, Zarlink assumes no liability for errors that may appear in this publication, or for liability otherwise arising from the application or use of any such information, product or service or for any infringement of patents or other intellectual property rights owned by third parties which may result from such application or use. Neither the supply of such information or purchase of product or service conveys any license, either express or implied, under patents or other intellectual property rights owned by Zarlink or licensed from third parties by Zarlink, whatsoever. Purchasers of products are also hereby notified that the use of product in certain ways or in combination with Zarlink, or non-Zarlink furnished goods or services may infringe patents or other intellectual property rights owned by Zarlink.

This publication is issued to provide information only and (unless agreed by Zarlink in writing) may not be used, applied or reproduced for any purpose nor form part of any order or contract nor to be regarded as a representation relating to the products or services concerned. The products, their specifications, services and other information appearing in this publication are subject to change by Zarlink without notice. No warranty or guarantee express or implied is made regarding the capability, performance or suitability of any product or service. Information concerning possible methods of use is provided as a guide only and does not constitute any guarantee that such methods of use will be satisfactory in a specific piece of equipment. It is the user's responsibility to fully determine the performance and suitability of any equipment using such information and to ensure that any publication or data used is up to date and has not been superseded. Manufacturing does not necessarily include testing of all functions or parameters. These products are not suitable for use in any medical products whose failure to perform may result in significant injury or death to the user. All products and materials are sold and services provided subject to Zarlink's conditions of sale which are available on request.

Purchase of Zarlink's I2C components conveys a licence under the Philips I2C Patent rights to use these components in an I2C System, provided that the system conforms to the I2C Standard Specification as defined by Philips.

Zarlink, ZL, the Zarlink Semiconductor logo and the Legerity logo and combinations thereof, VoiceEdge, VoicePort, SLAC, ISLIC, ISLAC and VoicePath are trademarks of Zarlink Semiconductor Inc.

**TECHNICAL DOCUMENTATION - NOT FOR RESALE**

---