

BIPOLAR ANALOG INTEGRATED CIRCUIT

μ PC4574GR-9LG

QUAD ULTRA LOW-NOISE, WIDEBAND, OPERATIONAL AMPLIFIER

DESCRIPTION

The μ PC4574GR-9LG is an ultra low noise, high slew rate quad operational amplifier specifically designed for audio, instrumentation, and communication circuits. The low noise and high frequency capabilities make it ideal for preamps and active filters for instrumentation and professional audio.

FEATURES

- Ultra low noise
- High slew rate
- Wide bandwidth
- Internal frequency compensation

ORDERING INFORMATION

Part Number	Package
μ PC4574GR-9LG-A	14-pin plastic TSSOP (5.72 mm (225))
μ PC4574GR(5)-9LG-A	14-pin plastic TSSOP (5.72 mm (225))

EQUIVALENT CIRCUIT (1/4 Circuit)

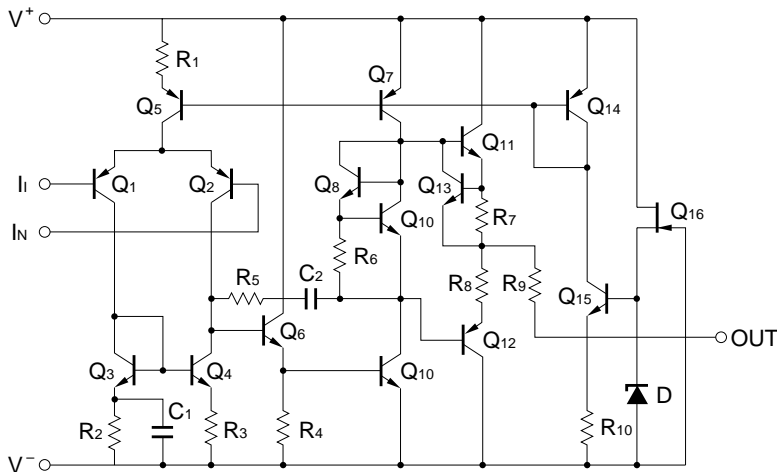

PIN CONFIGURATION (Top View)

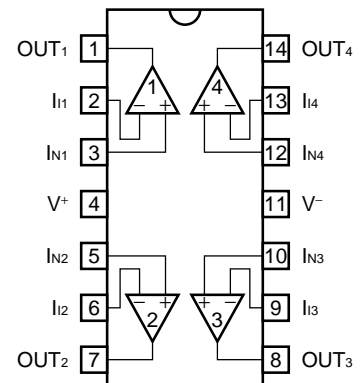

The information in this document is subject to change without notice. Before using this document, please confirm that this is the latest version.
 Not all products and/or types are available in every country. Please check with an NEC Electronics sales representative for availability and additional information.

ABSOLUTE MAXIMUM RATINGS (T_A = 25°C)

Parameter	Symbol	Ratings	Unit
Voltage between V ⁺ and V ⁻ ^{Note1}	V ⁺ - V ⁻	-0.3 to +36	V
Differential Input Voltage	V _{ID}	±30	V
Input Voltage ^{Note2}	V _I	V ⁻ -0.3 to V ⁺ +0.3	V
Output Voltage ^{Note3}	V _O	V ⁻ -0.3 to V ⁺ +0.3	V
Power Dissipation ^{Note4}	P _T	550	mW
Output Short Circuit Duration ^{Note5}		10	sec
Operating Ambient Temperature	T _A	-40 to +85	°C
Storage Temperature	T _{stg}	-55 to +125	°C

Notes 1. Reverse connection of supply voltage can cause destruction.

2. The input voltage should be allowed to input without damage or destruction. Even during the transition period of supply voltage, power on/off etc., this specification should be kept. The normal operation will establish when the both inputs are within the Common Mode Input Voltage Range of electrical characteristics.

3. This specification is the voltage which should be allowed to supply to the output terminal from external without damage or destructive. Even during the transition period of supply voltage, power on/off etc., this specification should be kept. The output voltage of normal operation will be the Output Voltage Swing of electrical characteristics.

4. Power dissipation is specified with mounting on the glass epoxy printed wiring board as follows, and ambient temperature condition is 46°C or less.

Board size : 100 mm square Thickness : 1.6 mm Copper area : 15% of mounting area (single side)

Thermal deleting factor is -7.0 mV/°C when operating ambient temperature is higher than 46°C.

5. Pay careful attention to the total power dissipation not to exceed the absolute maximum ratings, Note4.

RECOMMENDED OPERATING CONDITIONS

Parameter	Symbol	MIN.	TYP.	MAX.	Unit
Supply Voltage	V [±]	±4		±16	V
Output Current	I _o			±10	mA
Source Resistance	R _s			50	kΩ
Capacitive Load (A _v = +1)	C _L			100	pF

μPC4574GR-9LG

ELECTRICAL CHARACTERISTICS (T_A = 25°C, V[±] = ±15 V)

Parameter	Symbol	Conditions	MIN.	TYP.	MAX.	Unit
Input Offset Voltage	V _{IO}	R _S ≤ 50 Ω		±0.3	±5	mV
Input Offset Current ^{Note6}	I _{IO}			±10	±200	nA
Input Bias Current ^{Note6}	I _B			500	1000	nA
Large Signal Voltage Gain	A _V	R _L ≥ 2 kΩ, V _O = ±10 V	30000	300000		
Supply Current ^{Note7}	I _{CC}	I _O = 0 A		8.5	12	mA
Common Mode Rejection Ratio	CMR		80	100		dB
Supply Voltage Rejection Ratio	SVR		80	100		dB
Output Voltage Swing	V _{OM}	R _L ≥ 10 kΩ	±12	±13.4		V
		R _L ≥ 2 kΩ	±10	+12.8 -12.4		V
Common Mode Input Voltage Range	V _{ICM}		±12	±14		V
Slew Rate	SR	R _L ≥ 2 kΩ	4	6		V/μs
Gain Band Width Product	GBW	f _o = 100 kHz	10	14		MHz
Unity Gain Frequency	f _{unity}	open loop		7		MHz
Phase Margin	φ _{unity}	open loop		50		degree
Total Harmonic Distortion	THD	V _O = 3 V _{r.m.s.} , f = 20 Hz to 20 kHz (Fig.1)		0.002		%
Input Equivalent Noise Voltage	V _n	RIAA (Fig.2)		1.2		μV _{r.m.s.}
		FLAT+JIS A, R _S = 100 Ω (Fig.3)		0.53	0.65	μV _{r.m.s.}
Input Equivalent Noise Voltage Density	e _n	f _o = 10 Hz, R _S = 100 Ω		5.5		nV/√Hz
		f _o = 1 kHz, R _S = 100 Ω		5.0		nV/√Hz
Input Equivalent Noise Current Density	i _n	f _o = 1 kHz		0.7		pA/√Hz
Channel Separation		f = 20 Hz to 20 kHz		120		dB

Notes 6. Input bias currents flow out from IC. Because each currents are base current of PNP-transistor on input stage.

7. This current flows irrespective of the existence of use.

μPC4574GR(5)-9LG

ELECTRICAL CHARACTERISTICS (T_A = 25°C, V[±] = ±15V)

Parameter	Symbol	Conditions	MIN.	TYP.	MAX.	Unit
Input Offset Voltage	V _{IO}	R _S ≤ 50 Ω		±0.3	±1	mV
Input Offset Current ^{Note6}	I _{IO}			±10	±60	nA
Input Bias Current ^{Note6}	I _B			500	650	nA
Large Signal Voltage Gain	A _V	R _L ≥ 2 kΩ, V _O = ±10 V	50000	300000		
Supply Current ^{Note7}	I _{CC}	I _O = 0 A		8.5	11	mA
Common Mode Rejection Ratio	CMR		85	100		dB
Supply Voltage Rejection Ratio	SVR		85	100		dB
Output Voltage Swing	V _{OM}	R _L ≥ 10 kΩ	±13	±13.4		V
		R _L ≥ 2 kΩ	±11.5	+12.8 -12.4		V
Common Mode Input Voltage Range	V _{ICM}		±13	±14		V
Slew Rate	SR	R _L ≥ 2 kΩ	4	6		V/μs
Gain Band Width Product	GBW	f _o = 100 kHz	10	14		MHz
Unity Gain Frequency	f _{unity}	open loop		7		MHz
Phase Margin	φ _{unity}	open loop		50		degree
Total Harmonic Distortion	THD	V _O = 3 V _{r.m.s.} , f = 20 Hz to 20 kHz (Fig.1)		0.002		%
Input Equivalent Noise Voltage	V _n	RIAA (Fig.2)		1.2		μV _{r.m.s.}
		FLAT+JIS A, R _S = 100 Ω (Fig.3)		0.53	0.65	μV _{r.m.s.}
Input Equivalent Noise Voltage Density	e _n	f _o = 10 Hz, R _S = 100 Ω		5.5		nV/√Hz
		f _o = 1 kHz, R _S = 100 Ω		5.0		nV/√Hz
Input Equivalent Noise Current Density	i _n	f _o = 1 kHz		0.7		pA/√Hz
Channel Separation		f = 20 Hz to 20 kHz		120		dB

Notes 6. Input bias currents flow out from IC. Because each currents are base current of PNP-transistor on input stage.

7. This current flows irrespective of the existence of use.

MEASUREMENT CIRCUIT

Fig.1 Total Harmonic Distortion Measurement Circuit

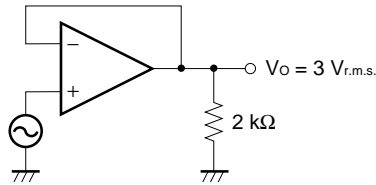

Fig.2 Noise Measurement Circuit (RIAA)

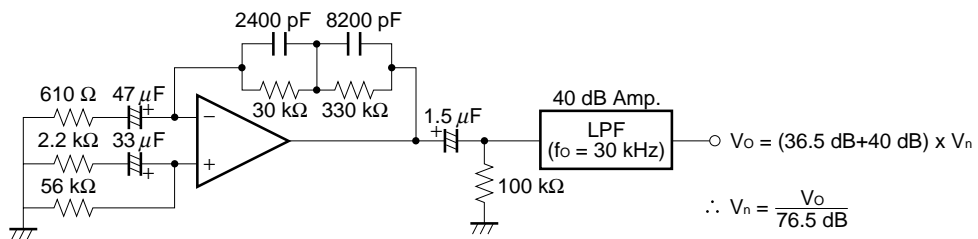
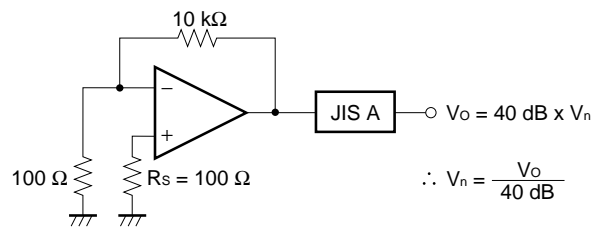
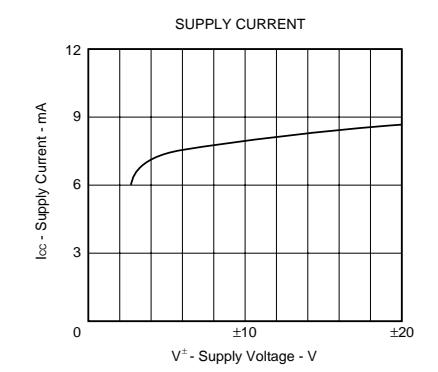
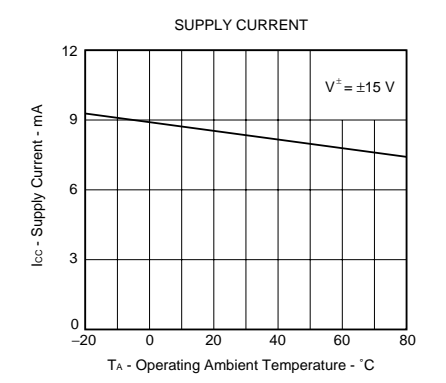
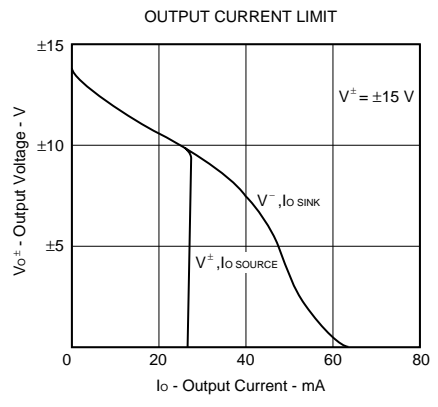
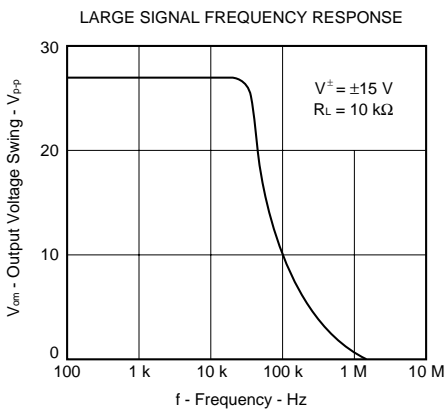
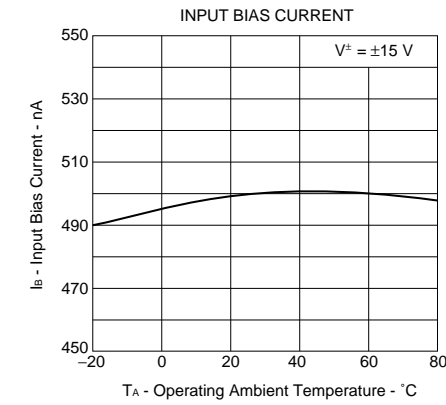
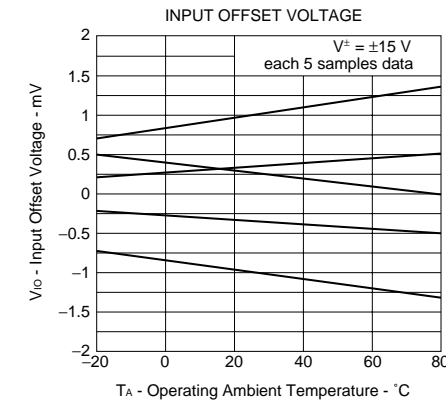
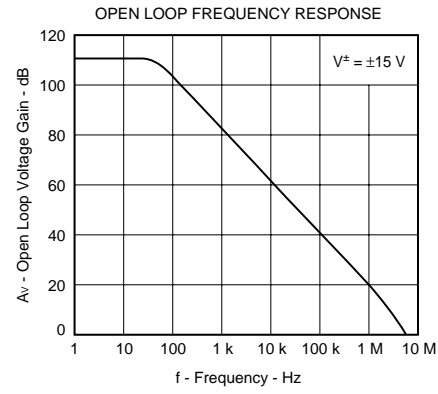
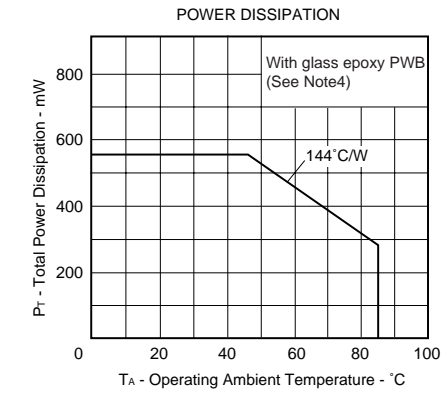
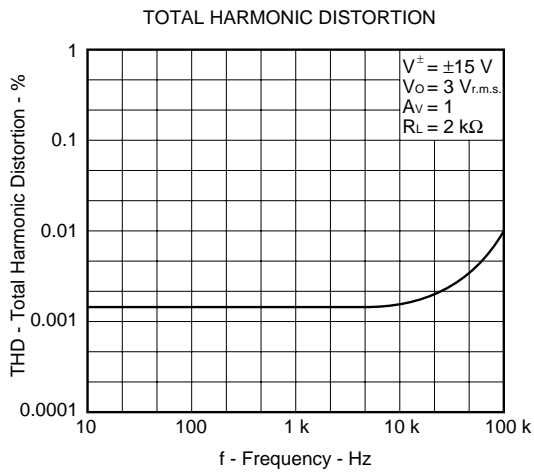
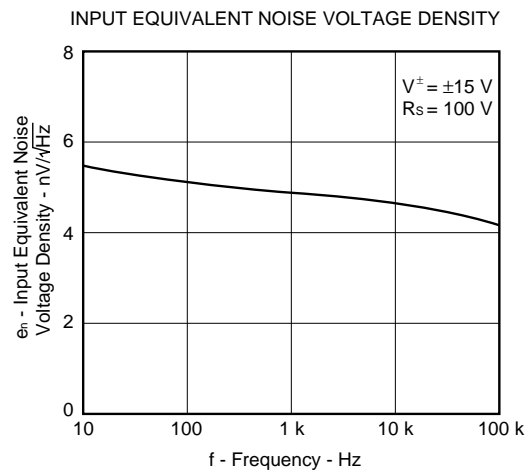
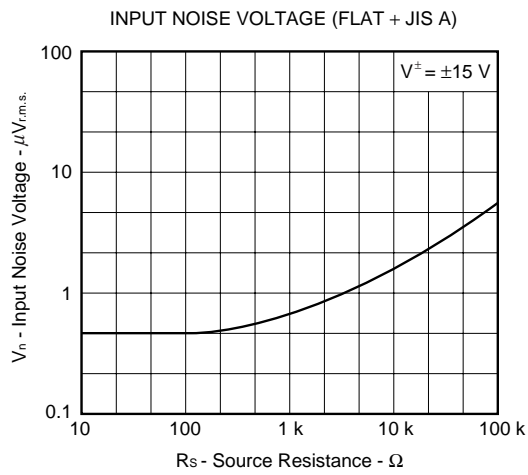
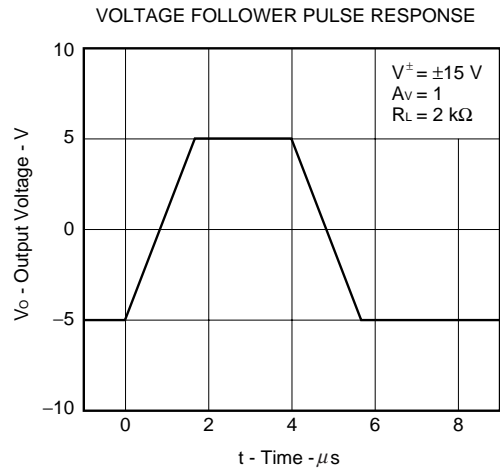
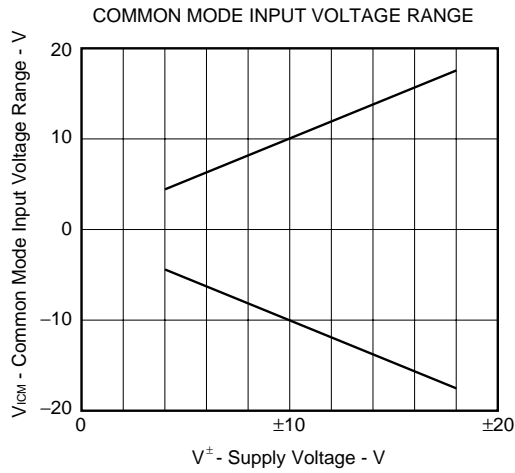

Fig.3 Flat Noise Measurement Circuit (FLAT+JIS A)



TYPICAL PERFORMANCE CHARACTERISTICS ($T_A = 25^\circ\text{C}$, TYP.)





PACKAGE DRAWING (Unit: mm)

14-PIN PLASTIC TSSOP (5.72mm (225))

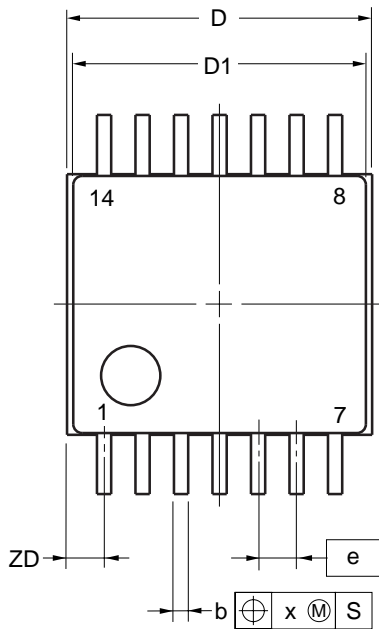

detail of lead end

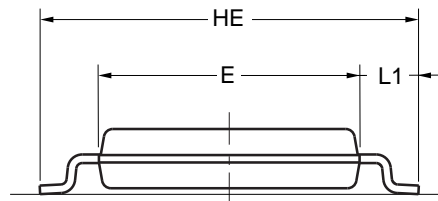
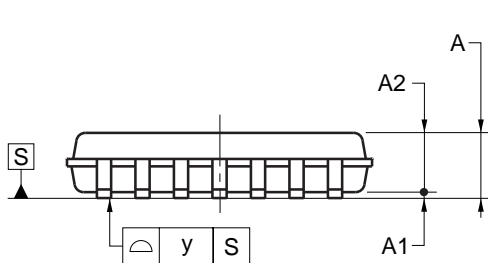
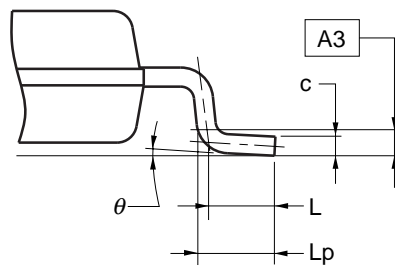

(UNIT:mm)

ITEM	DIMENSIONS
D	5.15±0.15
D1	5.00±0.10
E	4.40±0.10
HE	6.40±0.20
A	1.20 MAX.
A1	0.10±0.05
A2	1.00±0.05
A3	0.25
b	0.24 ^{+0.06} _{-0.05}
c	0.145±0.055
L	0.50
Lp	0.60±0.15
L1	1.00±0.20
θ	3° ^{+5°} _{-3°}
e	0.65
x	0.10
y	0.10
ZD	0.625

P14GR-65-9LG

NOTE

Each lead centerline is located within 0.10mm of its true position at maximum material condition.

© NEC Electronics Corporation 2005

RECOMMENDED SOLDERING CONDITIONS

The μPC4574GR-9LG should be soldered and mounted under the following recommended conditions.

For soldering methods and conditions other than those recommended below, contact an NEC Electronics sales representative.

For technical information, see the following website.

Semiconductor Device Mount Manual (<http://www.necel.com/pkg/en/mount/index.html>)

Process	Conditions	Symbol
Infrared Ray Reflow	Peak temperature: 260°C or below (Package surface temperature), Reflow time: 60 seconds or less (at 220°C or higher), Maximum number of reflow processes: 1 time.	IR60-00-3
Wave Soldering	Solder temperature: 260°C or below, Flow time: 10 seconds or less, Maximum number of flow processes: 1 time, Pre-heating temperature: 120°C or below (Package surface temperature).	WS60-00-1
Partial Heating Method	Pin temperature: 350°C or below, Heat time: 3 seconds or less (Per each side of the device).	P350

Caution Apply only one kind of soldering condition to a device, except for "partial heating method", or the device will be damaged by heat stress.

• **The information in this document is current as of November, 2006. The information is subject to change without notice. For actual design-in, refer to the latest publications of NEC Electronics data sheets or data books, etc., for the most up-to-date specifications of NEC Electronics products. Not all products and/or types are available in every country. Please check with an NEC Electronics sales representative for availability and additional information.**

• No part of this document may be copied or reproduced in any form or by any means without the prior written consent of NEC Electronics. NEC Electronics assumes no responsibility for any errors that may appear in this document.

• NEC Electronics does not assume any liability for infringement of patents, copyrights or other intellectual property rights of third parties by or arising from the use of NEC Electronics products listed in this document or any other liability arising from the use of such products. No license, express, implied or otherwise, is granted under any patents, copyrights or other intellectual property rights of NEC Electronics or others.

• Descriptions of circuits, software and other related information in this document are provided for illustrative purposes in semiconductor product operation and application examples. The incorporation of these circuits, software and information in the design of a customer's equipment shall be done under the full responsibility of the customer. NEC Electronics assumes no responsibility for any losses incurred by customers or third parties arising from the use of these circuits, software and information.

• While NEC Electronics endeavors to enhance the quality, reliability and safety of NEC Electronics products, customers agree and acknowledge that the possibility of defects thereof cannot be eliminated entirely. To minimize risks of damage to property or injury (including death) to persons arising from defects in NEC Electronics products, customers must incorporate sufficient safety measures in their design, such as redundancy, fire-containment and anti-failure features.

• NEC Electronics products are classified into the following three quality grades: "Standard", "Special" and "Specific".

The "Specific" quality grade applies only to NEC Electronics products developed based on a customer-designated "quality assurance program" for a specific application. The recommended applications of an NEC Electronics product depend on its quality grade, as indicated below. Customers must check the quality grade of each NEC Electronics product before using it in a particular application.

"Standard": Computers, office equipment, communications equipment, test and measurement equipment, audio and visual equipment, home electronic appliances, machine tools, personal electronic equipment and industrial robots.

"Special": Transportation equipment (automobiles, trains, ships, etc.), traffic control systems, anti-disaster systems, anti-crime systems, safety equipment and medical equipment (not specifically designed for life support).

"Specific": Aircraft, aerospace equipment, submersible repeaters, nuclear reactor control systems, life support systems and medical equipment for life support, etc.

The quality grade of NEC Electronics products is "Standard" unless otherwise expressly specified in NEC Electronics data sheets or data books, etc. If customers wish to use NEC Electronics products in applications not intended by NEC Electronics, they must contact an NEC Electronics sales representative in advance to determine NEC Electronics' willingness to support a given application.

(Note)

(1) "NEC Electronics" as used in this statement means NEC Electronics Corporation and also includes its majority-owned subsidiaries.

(2) "NEC Electronics products" means any product developed or manufactured by or for NEC Electronics (as defined above).