

Standard Products

VRG8653/VRG8654

Dual Voltage Regulator, 3.0 Amp, Positive & Negative Low Dropout (LDO), Adjustable Radiation Tolerant

www.aeroflex.com/voltreg

October 24, 2011



AEROFLEX
A passion for performance.

FEATURES

- Manufactured using  Linear Technology Corporation® Space Qualified RH1084 and RH1185 die
- Radiation performance
 - Total dose \geq 100 krad (Si)
- Two-Independent voltage regulators
- Thermal shutdown
- Adjustable Output Voltages
- **Positive** regulator features (RH1084)
 - Output voltage adjustable: 1.25V to 23V
 - Dropout voltage: 1.80V at 3.0A
 - 3-Terminal
 - Output current: 3.0A
 - Voltage reference: 1.25V +2%, -3.2%
 - Load regulation: 0.35% max
 - Line regulation: 0.25% max
 - Ripple rejection: >60dB
- **Negative** regulator features (RH1185)
 - Output voltage adjustable: -2.37 to -25V
 - Dropout voltage: 1.05V at 3.0A
 - 5-Terminal
 - Output current: 3.0A
 - Voltage reference: -2.370V \pm 3.5%
 - Load regulation: 0.8% max
 - Line regulation: 0.02% max
 - Ripple rejection: >60dB
- **Packaging** – Hermetic metal
 - Thru-hole or Surface mount
 - 8 Leads, .755"L x .415"W x .200"Ht
 - Power package
 - Weight - 6 gm max
- Designed for aerospace and high reliability space applications
- **Aeroflex Plainview's Radiation Hardness Assurance Plan is DLA Certified to MIL-PRF-38534, Appendix G.**

DESCRIPTION

The Aeroflex Plainview VRG8653/54 consists of one Positive Adjustable (RH1084) and one Negative Adjustable (RH1185) LDO voltage regulator, both capable of supplying 3.0A over the output voltage range as defined under recommended operating conditions. The VRG8653/54 offers excellent line and load regulation specifications and ripple rejection. There is full electrical isolation between the regulators and each regulator to the package.

Dropout ($V_{IN} - V_{OUT}$) decreases at lower load currents for both regulators.

The VRG8653/54 serves a wide variety of applications including SCSI-2 Active Terminator, High Efficiency Linear Regulators, Post Regulators for Switching Supplies, Constant Current Regulators, Battery Chargers and Microprocessor Supply.

The VRG8653/54 has been specifically designed to meet exposure to radiation environments. The VRG8653 is configured for a Thru-Hole 8 lead metal power package and the VRG8654 is configured for a Surface Mount 8 lead metal power package. It is guaranteed operational from -55°C to +125°C. Available screened in accordance with MIL-PRF-38534, the VRG8653/54 is ideal for demanding military and space applications.

For detailed performance characteristic curves, applications information and typical applications see the latest  Linear Technology Corporation® data sheets for their RH/LT1084 and RH/LT1185, which is available on-line at www.linear.com.

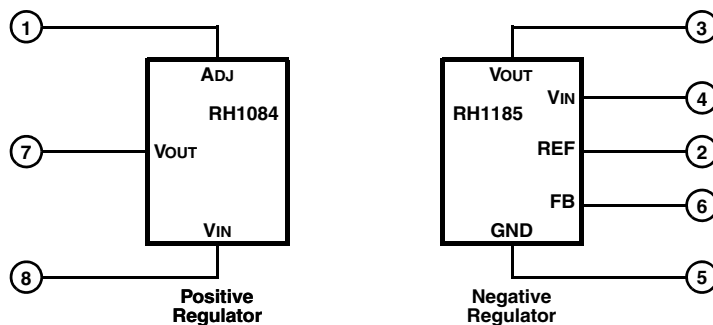

FIGURE 1 – SCHEMATIC

ABSOLUTE MAXIMUM RATINGS

PARAMETER	RANGE		UNITS
	RH1084	RH1185	
Input Voltage	+25	-35	VDC
Lead temperature (soldering 10 Sec)	300		°C
Input Output Differential	25	30	VDC
Load Current, maximum	+6.0	-4.5	A
Feedback & Reference Voltage	-	-7	VDC
Output Voltage	+25	-30	VDC
ESD (MIL-STD-883, M3015, Class 2)	2000 to 3999		V
Operating Junction Temperature Range	-55 to +150		°C
Storage Temperature Range	-65 to +150		°C
Thermal Resistance, Junction to case θ_{jc}	5		°C/W

NOTICE: Stresses above those listed under "Absolute Maximums Rating" may cause permanent damage to the device. These are stress rating only; functional operation beyond the "Operation Conditions" is not recommended and extended exposure beyond the "Operation Conditions" may effect device reliability.

RECOMMENDED OPERATING CONDITIONS

PARAMETER	RANGE		UNITS
	RH1084	RH1185	
Output Voltage Range	1.25 to 23	-2.37 to -25	VDC
Input Output Differential	1.8 to 24	1.05 to 29	VDC
Case Operating Temperature Range	-55 to +125		°C

ELECTRICAL PERFORMANCE CHARACTERISTICS

UNLESS OTHERWISE SPECIFIED: $-55^{\circ}\text{C} \leq T_C \leq +125^{\circ}\text{C}$

PARAMETER	SYM	CONDITIONS ($P \leq P_{MAX}$)	MIN	MAX	UNITS
RH1084 Positive LDO section only 1/					
Reference Voltage 2/, 3/	V_{REF}	$1.5V \leq (V_{IN} - V_{OUT}) \leq 15V, 10mA \leq I_{OUT} \leq 3.0A$	1.210	1.275	V
Line Regulation 2/, 3/	$\frac{\Delta V_{OUT}}{\Delta V_{IN}}$	$I_{LOAD} = 10mA, 1.5V \leq (V_{IN} - V_{OUT}) \leq 15V$	-	0.25	%
Load Regulation 2/, 3/	$\frac{\Delta V_{OUT}}{\Delta I_{OUT}}$	$10mA \leq I_{OUT} \leq 3.0A, (V_{IN} - V_{OUT}) = 3V$	-	0.35	%
Dropout Voltage 2/, 4/	V_{DROP}	$\Delta V_{REF} = 1\%, I_{OUT} = 3.0A$	-	1.8	V
Adjust Pin Current 2/	-		-	120	μA
Adjust Pin Current Change 2/	-	$10 mA \leq I_{OUT} \leq 3.0A, 1.5V \leq (V_{IN} - V_{OUT}) \leq 15V$	-	5	μA
Minimum Load Current 5/	I_{MIN}	$(V_{IN} - V_{OUT}) = 25V$	-	10	mA
Current Limit	I_{CL}	$(V_{IN} - V_{OUT}) = 5V$	5.25		A
Ripple Rejection 3/	-	$I_{OUT} = 3.0A, (V_{IN} - V_{OUT}) = 3V, f = 120Hz, C_{ADJ} = C_{OUT} = 25\mu F$	60	-	dB
Thermal Regulation	-	30ms pulse, $T_C = +25^{\circ}\text{C}$	-	0.015	%/W
V_{REF} Long-Term Stability 5/	-	Burn In: $T_C = +125^{\circ}\text{C}$ @ 1000hrs minimum, tested @ 25°C	-	1.0	%

ELECTRICAL PERFORMANCE CHARACTERISTICS (con't)

UNLESS OTHERWISE SPECIFIED: $-55^{\circ}\text{C} \leq T_C \leq +125^{\circ}\text{C}$

PARAMETER	SYM	CONDITIONS (P ≤ P _{MAX})	MIN	MAX	UNITS
RH1185 Negative LDO section only 9/					
Reference Voltage (At pin 6) 2/	V _{REF}	1mA ≤ I _{OUT} ≤ 3A, V _{IN} - V _{OUT} = 1.2V to 28V, V _{OUT} = -5V	-2.29	-2.45	V
Dropout Voltage 2/, 6/	V _{DROP}	I _{OUT} = 0.5A, V _{OUT} = -5V	-	0.425	V
		I _{OUT} = 3A, V _{OUT} = -5V	-	1.05	V
Line Regulation 2/, 10/	$\frac{\Delta V_{OUT}}{\Delta V_{IN}}$	1.0V ≤ V _{IN} - V _{OUT} ≤ 20V, V _{OUT} = -5V	-	0.02	%/V
Load Regulation 2/, 10/	$\frac{\Delta V_{OUT}}{\Delta I_{OUT}}$	5mA ≤ I _{OUT} ≤ 3A, V _{IN} - V _{OUT} = 1.5V to 10V, V _{OUT} = -5V	-	0.8	%
Minimum Input Voltage 2/, 7/	V _{IN MIN}	I _{OUT} = 3A, V _{OUT} = V _{REF}	-	-4.50	V
Internal Current Limit (See Graph for Guaranteed Curve - See Figure 6) 2/, 13/	I _{CL}	1.5V ≤ V _{IN} - V _{OUT} ≤ 10V	3.3	4.55	A
		V _{IN} - V _{OUT} = 15V	2.0	4.5	A
		V _{IN} - V _{OUT} = 20V	1.0	3.1	A
		V _{IN} - V _{OUT} = 30V 5/	0.2	1.6	A
External Current Limit 2/	I _{LIM}	R _{LIM} = 5KΩ, (V _{IN} - V _{OUT}) = 1.5V 12/	2.7	3.7	A
		R _{LIM} = 15KΩ, (V _{IN} - V _{OUT}) = 1.5V 12/	0.9	1.6	A
Quiescent Supply Current 2/, 8/	I _Q	I _{OUT} = 5mA, V _{OUT} = V _{REF} , -4V ≤ V _{IN} ≤ -25V	-	3.5	mA
Supply Current Change with Load 2/	I _{QA}	V _{IN} - V _{OUT} = V _{SAT} 11/	-	35	mA/A
		V _{IN} - V _{OUT} ≥ 2V	-	21	mA/A
Ripple Rejection	-	I _{OUT} = 3.0A, V _{IN} - V _{OUT} = 3V, f = 120Hz,	60	-	dB
Thermal Regulation (See application information LT1185) 5/	-	V _{IN} - V _{OUT} = 10V, I _{OUT} = 5mA to 2A, T _C = +25°C	-	0.014	%/W

Notes

- 1/ The manufacturer's output current rating for the RH1084MK positive regulator integrated circuit is 5.0 Amps. For Compliance with the Current Density specification of MIL-STD-883 Rev. C, the electrical performance characteristics are specified at an output current of 3.0 Amps.
- 2/ Specification derated to reflect total dose exposure to 100krads (Si) at +25°C.
- 3/ Line and load regulation are guaranteed up to the maximum power dissipation of 25W. Power dissipation is determined by the input/output differential voltage and the output current. Guaranteed maximum power dissipation will not be available over the full input/output voltage range.
- 4/ Dropout voltage is specified over the full output current range of the device.
- 5/ Not tested. Shall be guaranteed by design, characterization, or correlation to other tested parameters.
- 6/ Dropout voltage is tested by reducing input voltage until the output drops 1% below its nominal value. Tests are done at 0.5A and 3A. The power transistor looks basically like a pure resistance in this range so that minimum differential at any intermediate current can be calculated by interpolation; V_{DROPOUT} = 0.25V + (0.25Ω x I_{OUT}). For load current less than 0.5A, see Figure 4.
- 7/ "Minimum input voltage" is limited by base emitter voltage drive of the power transistor section, not saturation as measured in Note 6. For output voltages below 4V, "minimum input voltage" specification may limit dropout voltage before transistor saturation limitation.
- 8/ Supply current is measured on the ground pin, and does not include load current, R_{LIM}, or output divider current.
- 9/ The 25W power level is guaranteed for an input-output voltage of 8.3V to 17V. At lower voltages the 3A limit applies, and at higher voltages the internal power limiting may restrict regulator power below 25W.
- 10/ Line and load regulation are measured on a pulse basis with a pulse width of 2ms, to minimize heating. DC regulation will be affected by thermal regulation and temperature coefficient of the reference.
- 11/ V_{SAT} is the maximum specified dropout voltage; 0.25V + (0.25Ω x I_{OUT}).
- 12/ Current limit is programmed with a resistor from REF pin to GND pin. R_{LIM} = 15KΩ/I_{LIM}.
- 13/ Pulsed @ <10% duty cycle @ +25°C

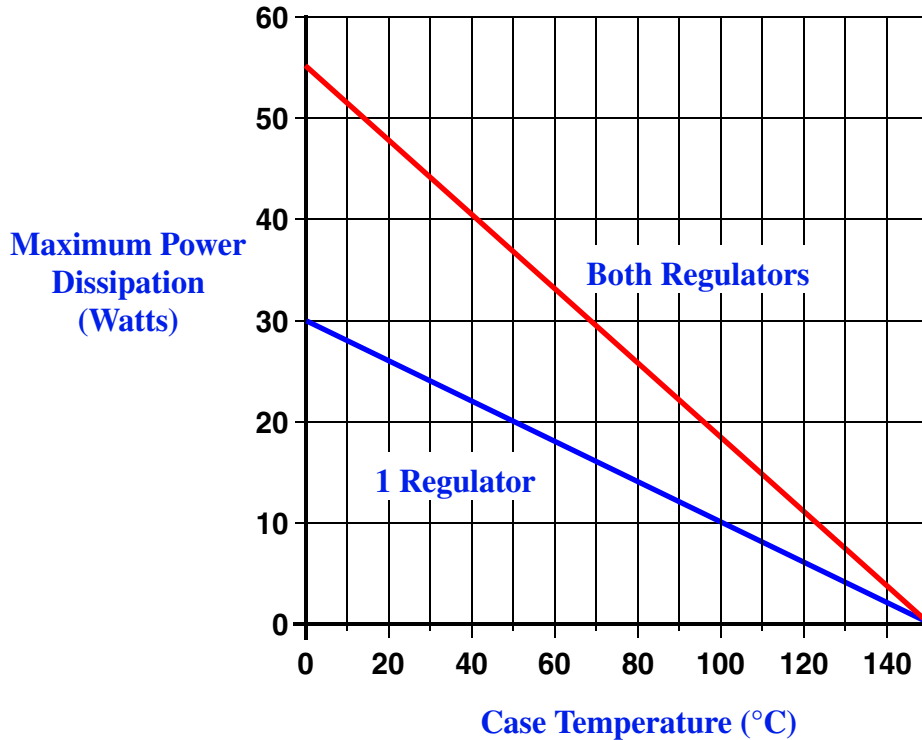

FIGURE 2 – MAXIMUM POWER vs CASE TEMPERATURE

The maximum Power dissipation is limited by the thermal shutdown function of each regulator chip in the VRG8653/54. The graph above represents the achievable power before the chip shuts down. The first line in the graph represents the maximum power dissipation of the VRG8653/54 with one regulator on (the other off) and the other line represents both regulators on dissipating equal power. If both regulators are on and one regulator is dissipating more power than the other, the maximum power dissipation of the VRG8653/54 will fall between the two lines. This graph is based on the maximum junction temperature of 150°C and a thermal resistance (Θ_{JC}) of 5°C/W.

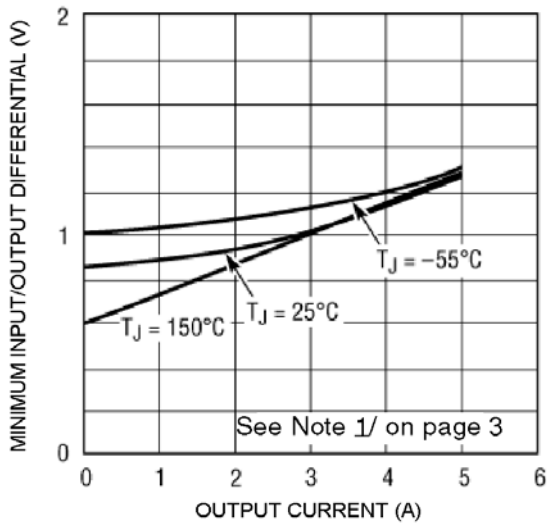

FIGURE 3 – RH1084 DROPOUT VOLTAGE TYPICAL CURVE

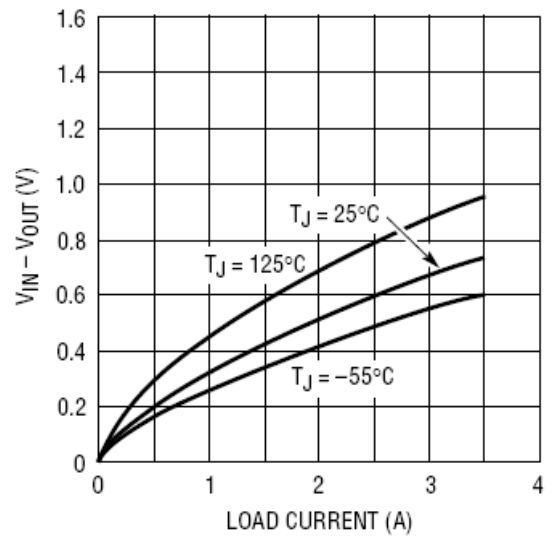

FIGURE 4 – RH1185 DROPOUT VOLTAGE TYPICAL CURVE

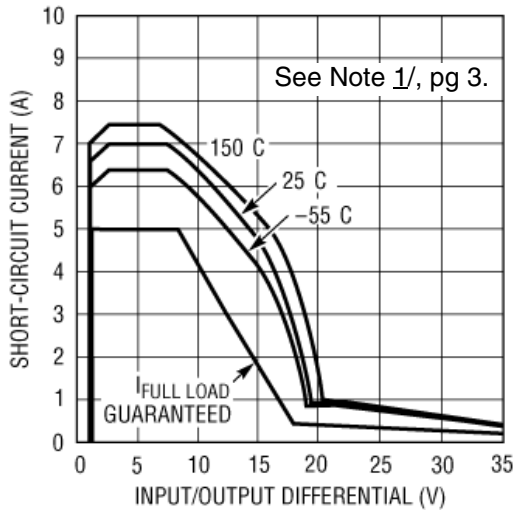

FIGURE 5 – RH1084 SHORT CIRCUIT CURRENT

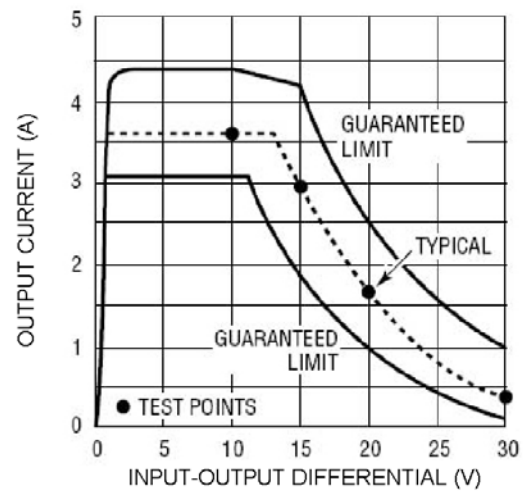

FIGURE 6 – RH1185 INTERNAL CURRENT LIMIT

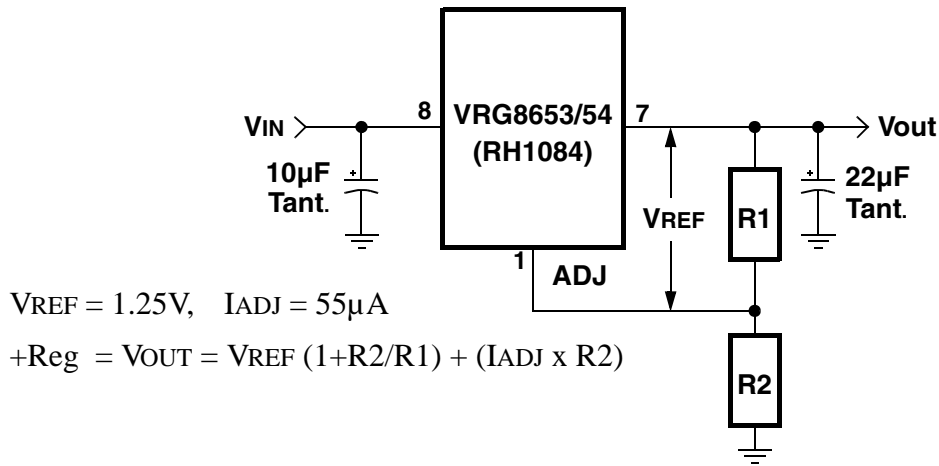

FIGURE 7 – BASIC RH1084 POSITIVE ADJUSTABLE REGULATOR APPLICATION

The RH1185 output voltage is set by two external resistors. Internal reference voltage is trimmed to 2.37V so that a standard 1% 2.37k resistor (R1) can be used to set divider current at 1mA. R2 is then selected from:

$$R2 = \frac{(V_{OUT} - 2.37) R1}{V_{REF}}$$

for $R1 = 2.37k$ and $V_{REF} = 2.37V$, this reduces to:

$$R2 = \frac{V_{OUT} - 2.37}{10^{-3}}$$

suggested values of 1% resistors are shown.

V_{OUT}	$R2$ WHEN $R1 = 2.37k$
2.5V	130Ω
3.3V	930Ω
5V	2.67k
12V	9.76k
15V	12.7k

SETTING OUTPUT VOLTAGE

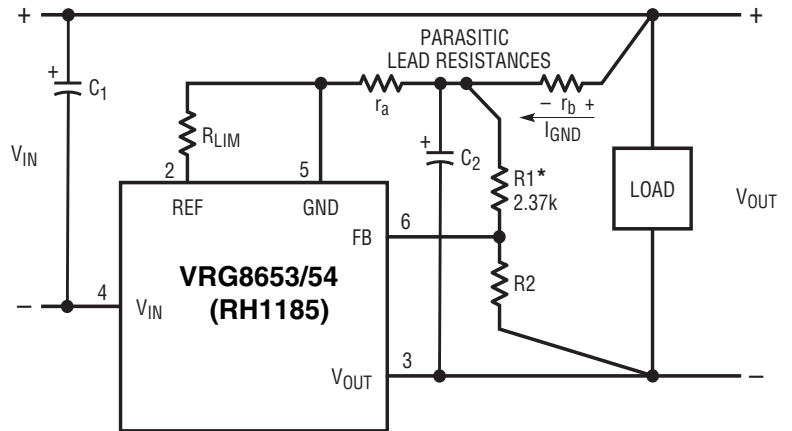

*R1 SHOULD BE CONNECTED DIRECTLY TO GROUND LEAD, NOT TO THE LOAD, SO THAT $r_a \approx 0\Omega$. THIS LIMITS THE OUTPUT VOLTAGE ERROR TO $(I_{GND})(r_b)$. ERRORS CREATED BY r_a ARE MULTIPLIED BY $(1 + R2/R1)$. NOTE THAT V_{OUT} INCREASES WITH INCREASING GROUND PIN CURRENT. R2 SHOULD BE CONNECTED DIRECTLY TO LOAD FOR REMOTE SENSING. $C1 = C2 \geq 2\mu F$ Tantalum.

R1 & R2 LOCATION & PROPER CONNECTION OF POSITIVE SENSE LEAD

FIGURE 8 – BASIC RH1185 NEGATIVE ADJUSTABLE REGULATOR APPLICATION

TABLE I – PIN NUMBERS vs FUNCTION

PIN	FUNCTION
1	POS_ADJ_1
2	NEG_REF_2
3	NEG_VOUT_2
4	NEG_VIN_2
5	NEG_GND_2
6	NEG_FB_2
7	POS_VOUT_1
8	POS_VIN_1

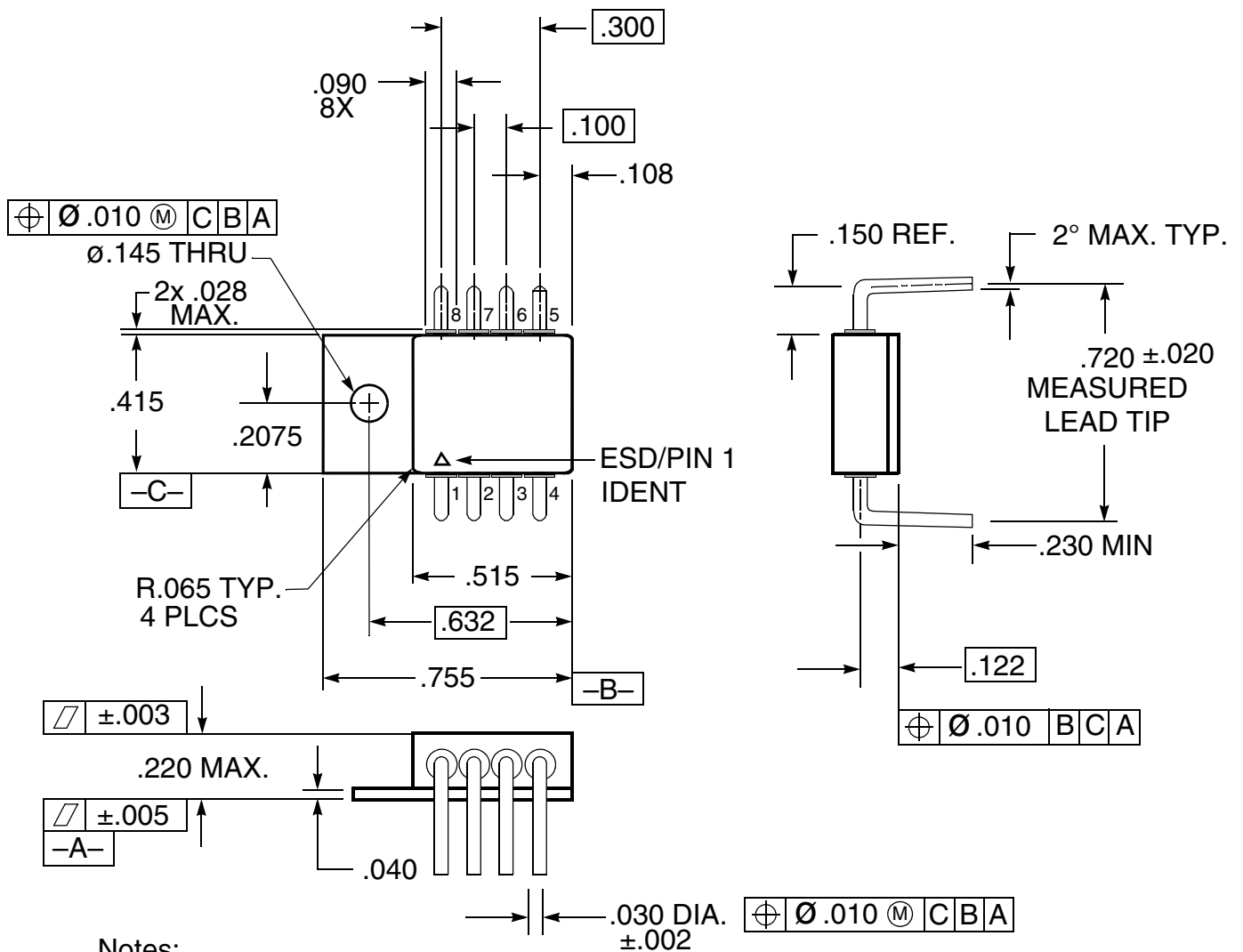

Notes:

1. Dimension Tolerance: $\pm .005$ inches
2. Package contains BeO substrate
3. Case electrically isolated

FIGURE 9 – VRG8653 PACKAGE OUTLINE — THRU-HOLE POWER PACKAGE

ORDERING INFORMATION

MODEL	DLA SMD #	SCREENING	PACKAGE
VRG8653-7	-	Commercial Flow, +25°C testing only	8 Lead Thru-Hole Power Pkg
VRG8653-S	-	Military Temperature, -55°C to +125°C Screened in accordance with the individual Test Methods of MIL-STD-883 for Space Applications	
VRG8653-201-1S	5962-1021301KUC	DLA SMD Pending	
VRG8653-201-2S	5962-1021301KUA		
VRG8654-7	-	Commercial Flow, +25°C testing only	8 Lead Surface Mount Power Pkg
VRG8654-S	-	Military Temperature, -55°C to +125°C Screened in accordance with the individual Test Methods of MIL-STD-883 for Space Applications	
VRG8654-201-1S	5962-1021301KZC	DLA SMD Pending	
VRG8654-201-2S	5962-1021301KZA		

EXPORT CONTROL:

This product is controlled for export under the International Traffic in Arms Regulations (ITAR). A license from the U.S. Department of State is required prior to the export of this product from the United States.

EXPORT WARNING:

Aeroflex's military and space products are controlled for export under the International Traffic in Arms Regulations (ITAR) and may not be sold or proposed or offered for sale to certain countries. (See ITAR 126.1 for complete information.)

PLAINVIEW, NEW YORK
Toll Free: 800-THE-1553
Fax: 516-694-6715

INTERNATIONAL
Tel: 805-778-9229
Fax: 805-778-1980

NORTHEAST
Tel: 603-888-3975
Fax: 603-888-4585

SE AND MID-ATLANTIC
Tel: 321-951-4164
Fax: 321-951-4254

WEST COAST
Tel: 949-362-2260
Fax: 949-362-2266

CENTRAL
Tel: 719-594-8017
Fax: 719-594-8468



www.aeroflex.com info-ams@aeroflex.com

Aeroflex Microelectronic Solutions reserves the right to change at any time without notice the specifications, design, function, or form of its products described herein. All parameters must be validated for each customer's application by engineering. No liability is assumed as a result of use of this product. No patent licenses are implied.



Our passion for performance is defined by three attributes represented by these three icons: solution-minded, performance-driven and customer-focused

 and the Linear Technology logo are registered trademarks and RH1084 & RH1185 are a copyright of Linear Technology Corporation.