

NOTE: The document identifier and heading has been changed on this page to reflect that this is a performance specification. There are no other changes to this document. The document identifier on subsequent pages has not been changed, but will be changed the next time this document is revised.

MIL-PRF-39012/67B  
24 September 1986  
SUPERSEDING  
MIL-C-39012/67A  
28 July 1983

### PERFORMANCE SPECIFICATION

#### CONNECTORS, PLUGS, ELECTRICAL, COAXIAL, RADIO FREQUENCY, SERIES SMB (CABLED, SOCKET CONTACT, CLASS 2)

This specification is approved for use by all Departments and Agencies of the Department of Defense.

The requirements for acquiring the connectors described herein shall consist of this specification sheet and the latest issue of MIL-PRF-39012.

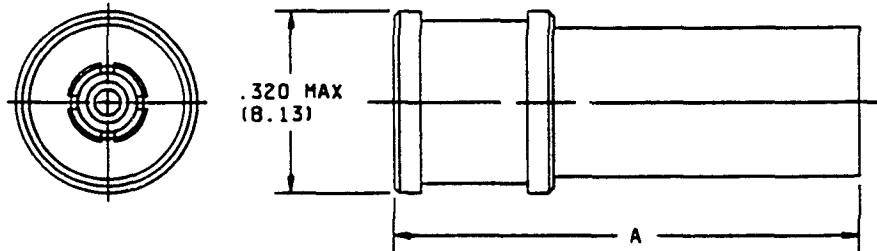

#### NOTES:

1. Dimensions are in inches.
2. Metric equivalents are in parentheses.
3. Metric equivalents are given for general information only.
4. For dimension "A" see table I.
5. Wrench flats to accommodate standard wrench per FED-STD-H28, appendix 10.
6. Dimension "A" defines the maximum length of connector when assembled to cable.
7. Maximum overall diameter of the connector is .320 (8.13 mm).
8. All undimensioned pictorial representations are for reference purposes only.

FIGURE 1. General configuration.

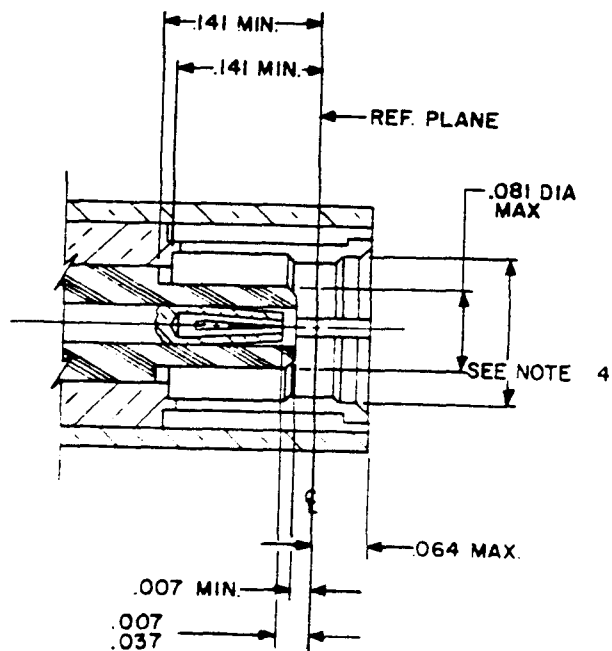

INCHES	MM
.007	.18
.019	.48
.021	.53
.037	.94
.064	1.63
.081	2.06
.117	2.97
.141	3.58

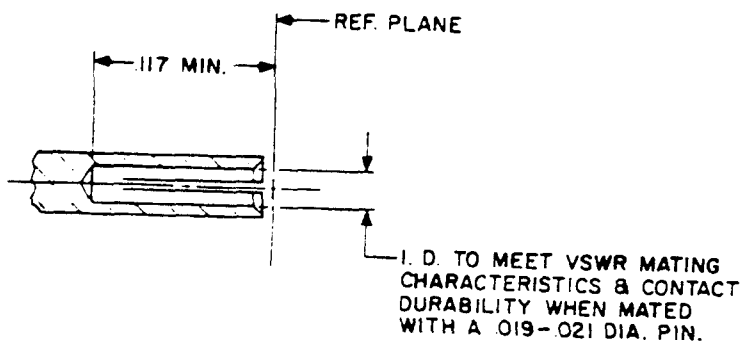

NOTES:

1. Dimensions are in inches.
2. Metric equivalents are given for general information only.
3. Method of slotting of inner contact optional.
4. Must meet the longitudinal force requirements of force to engage and disengage when mated with its mating gage per figure 4.
5. All undimensioned pictorial representations are for reference purposes only.

FIGURE 2. Mating dimensions for socket terminations.

TABLE I. Part numbers, usage cross-reference, basic overall dimensions.

Part number	Applicable cable no. $\cong$	Typical mating connector (optional hardware) $\frac{1}{2}$	Dimensions	Inches (millimeters) maximum $\frac{3}{4}$
CATEGORY A - FIELD SERVICEABLE (NO SPECIAL TOOLS REQUIRED)				
M39012/67-0003 $\frac{4}{5}$	M17/93-RG178* $\emptyset$ M17/169-00001 $\emptyset$	M39012/68-0003 M39012/70-0003	A	.88 (22.35)
M39012/67-0004 $\frac{4}{5}$	M17/119-RG174 M17/173-00001 $\emptyset$ M17/113-RG316* $\emptyset$ M17/172-00001 $\emptyset$ M17/94-RG179 $\Delta$ $\emptyset$	M39012/68-0004 M39012/70-0004	A	.88 (22.35)
M39012/67-0103 $\frac{4}{5}$	M17/93-RG178* $\emptyset$ M17/169-00001 $\emptyset$	M39012/68-0103 M39012/70-0103	A	.88 (22.35)
M39012/67-0104 $\frac{4}{5}$	M17/119-RG174 M17/173-00001 $\emptyset$ M17/113-RG316* $\emptyset$ M17/172-00001 $\emptyset$ M17/94-RG179 $\Delta$ $\emptyset$	M39012/68-0104 M39012/70-0104	A	.88 (22.35)
CATEGORY C - FIELD REPLACEABLE (MIL-C-22520/5-01 BASIC CRIMPING TOOL) $\frac{6}{7}$				
M39012/67-0011 $\frac{4}{5}$	M17/93-RG178* $\emptyset$ M17/169-00001 $\emptyset$	M39012/68-0011 M39012/70-0011	A	1.10 (27.94)
M39012/67-0012 $\frac{4}{5}$	M17/119-RG174 $\Sigma$ M17/173-00001 $\Sigma$ $\emptyset$ M17/113-RG316* $\emptyset$ $\Sigma$ M17/172-00001 $\Sigma$ $\emptyset$ M17/94-RG179 $\Delta$ $\emptyset$ $\Sigma$	M39012/68-0012 M39012/70-0012	A	1.10 (27.94)

See footnotes at end of table.

TABLE I. Part numbers, usage cross-reference, basic overall dimensions - Continued.

Part number	Applicable cable no. $\equiv$	Typical mating connector (optional hardware) $\frac{1/}{2/}$	Dimensions	Inches (millimeters) maximum $\frac{3/}{6/}$
CATEGORY C - FIELD REPLACEABLE (MIL-C-22520/5-01 BASIC CRIMPING TOOL)				
M39012/67-0016 $\frac{4/}{}$	M17/93-RG178* $\frac{\infty}{}$ M17/169-00001 $\frac{\infty}{\phi}$	M39012/68-0016 M39012/70-0016	A	1.10 (27.94)
M39012/67-0017 $\frac{4/}{}$	M17/119-RG174 $\frac{\Delta}{}$ M17/173-00001 $\frac{\Delta}{\phi}$ M17/113-RG316* $\frac{\infty}{\Sigma}$ M17/172-00001 $\frac{\Delta}{\phi}$ M17/94-RG179 $\frac{\Delta}{\phi}$	M39012/68-0017 M39012/70-0017	A	1.10 (27.94)

- $\frac{1/}{}$  Optional hardware part numbers are in parentheses.
- $\frac{2/}{}$  Mating connector part numbers are for reference only. All mating connectors may not be listed.
- $\frac{3/}{}$  Millimeters are in parentheses.
- $\frac{4/}{}$  These connectors have captivated center contacts.
- $\frac{5/}{}$  Connector bodies shall be gold-plated per MIL-G-45204, type II, class 1.
- $\frac{6/}{}$  Category C connectors are assembled by means of the applicable crimping tool per MIL-C-22520 to the specified cable stripped in accordance with figure 3 herein.
- $\equiv$  The RG cables are specified with the basic number. The latest version of each cable shall be applicable.
- \*
- $\frac{\infty}{}$  Cable to be used when performing tests requiring cable except as in notes  $\frac{\Delta}{}$  and  $\frac{\phi}{}$ .
- $\frac{\Delta}{}$  Cable to be used for the +200°C thermal shock tests.
- $\frac{\Delta}{}$  These are not 50-ohm cables, therefore, when attached to the specified connectors, VSWR, RF leakage and insertion loss are not applicable.
- $\frac{\infty}{}$  M22520/5-33 Closure B or M22520/5-03 Closure B.
- $\frac{\Sigma}{}$  M22520/5-35 Closure B or M22520/5-03 Closure A.
- $\frac{\phi}{}$  Caution is directed to the application of this cable above 400 MHz. Attenuation is tested only at 400 MHz. SRL and power handling capabilities are not stipulated herein.

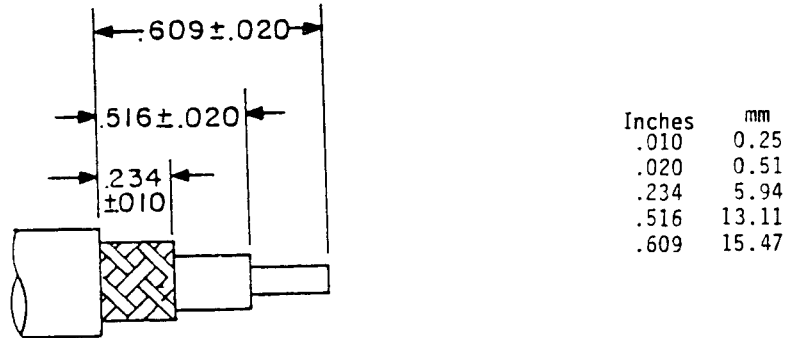

## NOTES:

1. Dimensions are in inches.
2. Metric equivalents are given for general information only.

FIGURE 3. Recommended cable stripping dimensions for category C connectors.

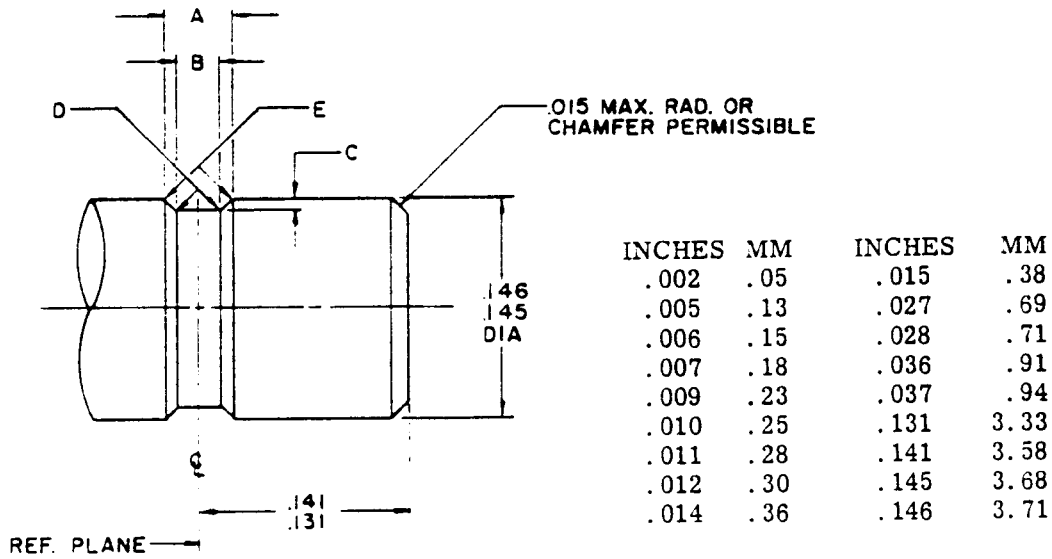

	A	B	C	D	E
GAUGE #1	.037 .036	.015 .014	.010 .009	.005 MAX RAD	.006 .002 RAD
GAUGE #2	.028 .027	.012 .011	.007 .006	.005 MAX RAD	.006 .002 RAD

NOTES:

1. Dimensions are in inches.
2. Metric equivalents are given for general information only.
3. Gage No. 1 to be used for longitudinal force initial engagement, and maximum engagement requirement after 500 cycles.
4. Gage No. 2 to be used for minimum disengagement requirement after 500 cycles of mating and unmating.
5. Material - steel with a  $\sqrt{16}$  finish.

FIGURE 4. Test gage for force to engage and disengage.

## ENGINEERING DATA:

Nominal impedance: 50 ohms.

Frequency range: 0 to 4 GHz.

Voltage rating:

<u>Cables</u>	<u>Voltage max (at sea level)</u> <u>V rms</u>	<u>Voltage max (70,000 ft)</u> <u>V rms</u>
M17/93-RG178, M17/169-00001	250	60
M17/119-RG174, M17/173-00001, M17/94-RG179, M17/113-RG316, M17/172-00001	335	85

Temperature rating: -65°C to +165°C.

## REQUIREMENTS:

Dimensions and configuration: See figure 1.

Force to engage and disengage:

Longitudinal force: 14 pounds maximum.

Torque: Not applicable.

Coupling proof torque: Not applicable.

Inspection conditions: Torque not applicable.

Mating characteristics: See figure 2 for dimensions.

Center contact (socket):

Oversize test pin: .0215 diameter minimum (nonclosed entry contacts only).

Insertion depth: .050 minimum.

Number of insertions: One.

Insertion force test:

Steel test pin diameter: .021 minimum.

Test pin finish: 16 microinches.

Insertion force: 2.5 pounds maximum.

Withdrawal force test:

Steel test pin diameter: .019 maximum.

Withdrawal force: 1 ounce minimum.

Test pin finish: 16 microinches.

Hermetic seal: Not applicable.

Leakage (pressurized connectors): Not applicable.

Insulation resistance: Method 302, test condition 3, MIL-STD-202. 1,000 megohms minimum.

Center contact retention: 4.0 pounds minimum axial force.

Torque: Not applicable.

Resistance to test prod damage: Not applicable.

Corrosion (salt spray): Method 101, test condition B, MIL-STD-202.

Voltage standing wave ratio (VSWR): From 500 MHz to 4 GHz, or approximately 90 percent of upper cutoff frequency of the cable, whichever is lower.

<u>Cables</u>	<u>VSWR</u>
M17/93-RG178	1.30 + .04 F (GHz)
M17/119-RG174, M17/113-RG316	1.25 + .04 F (GHz)

Swept frequency VSWR test setup:

Item 5: VSWR shall be less than  $1.05 + .0025 F$  (F in GHz).

Item 16: VSWR shall be less than  $1.05 + .0025 F$  (F in GHz).

Second step of VSWR checkout procedure: VSWR shall be less than  $1.10 + .01 F$  (F in GHz).

Group B inspection: VSWR shall be less than  $1.08 + .017 F$  (F in GHz).

Qualification and group C inspection: VSWR shall not exceed 1.15.

Connector durability:

Insertion and withdrawal force: 500 cycles minimum at 12 cycles per minute maximum. The connector shall meet the mating characteristics and force to engage and disengage requirements.

Initial: 14 pounds maximum.

Final: 14 pounds maximum engage and disengage; 2 pounds minimum disengagement.

Contact resistance: In milliohms maximum:

	<u>Initial</u>	<u>After environment</u>
Center contact:	6.0	8.0
Outer contact:	1.0	1.5
Braid to body:	1.0	Not applicable

Dielectric withstanding voltage: Method 301 of MIL-STD-202.

<u>Cables</u>	<u>V rms (at sea level)</u>
M17/93-RG178, M17/169-00001	750
M17/119-RG174, M17/173-00001, M17/94-RG179, M17/113-RG316, M17/172-00001	1,000

Vibration, high frequency: Method 204, test condition B, MIL-STD-202.

Shock (specified pulse): Method 213, test condition B, MIL-STD-202.

Thermal shock: Method 107, test condition B, MIL-STD-202, except test high temperature shall be +85°C. High temperature shall be +200°C for connectors using +200°C cables (see table I or table III).



Moisture resistance: Not applicable.

Corona level:

Altitude: 70,000 feet.

<u>Cables</u>	<u>Volts (min)</u>
M17/93-RG178, M17/169-00001	185
M17/119-RG174, M17/173-00001, M17/94-RG179, M17/113-RG316, M17/172-00001	250

RF high potential withstanding voltage:

Frequency: 5 MHz.

Leakage current: Not applicable.

<u>Cables</u>	<u>Volts rms</u>
M17/93-RG178, M17/169-00001	500
M17/119-RG174, M17/173-00001, M17/94-RG179, M17/113-RG316, M17/172-00001	700

Cable retention force: The cable retention force shall be as specified in table II.

TABLE II. Cable retention force.

Cable dielectric outer diameter	Noncrimp	Crimp
	single braid Center contact Captive	single braid Center contact Captive
<u>Inches (max)</u>	<u>Pounds (min)</u>	<u>Pounds (min)</u>
.036	13	13
.066	25	25

Coupling mechanism retention force: Not applicable.

RF leakage: -55 dB minimum, tested at a frequency between 2 and 3 GHz.

Insertion loss: .30 dB maximum at 1.5 GHz.

Part number: M39012/67- (dash number from table I or III, as applicable).

Group qualification and retention testing: See table IV.

Cross-reference of part numbers: See table V.

TABLE III. Category B - Nonfield replaceable (special tools may be required).

Not for Air Force or Navy use. For OEM use only.
--

Part number	Applicable cable no. $\equiv$	Typical mating connector (optional hardware) 1/ 2/	Dimensions	Inches (millimeters) maximum <u>3/</u>
M39012/67B0008 4/ 5/	M17/93-RG178* $\emptyset$ M17/169-00001 $\emptyset$	M39012/6880008 M39012/7080008	A	1.10 (27.94)
M39012/67B0009 4/ 5/	M17/119-RG174 M17/173-00001 $\emptyset$ M17/113-RG316* $\emptyset$ M17/172-00001 $\emptyset$	M39012/6880009 M39012/7080009	A	1.10 (27.94)
M39012/67B0010 4/ 5/	M17/94-RG179 $\Delta$ * $\emptyset$	M39012/6880010 M39012/7080010	A	1.10 (27.94)
M39012/67B0013 4/	M17/93-RG178* $\emptyset$ M17/169-00001 $\emptyset$	M39012/6880013 M39012/7080013	A	1.10 (27.94)
M39012/67B0014 4/	M17/119-RG174 M17/173-00001 $\emptyset$ M17/113-RG316* $\emptyset$ M17/172-00001 $\emptyset$	M39012/6880014 M39012/7080014	A	1.10 (27.94)
M39012/67B0015 4/	M17/94-RG179 $\Delta$ * $\emptyset$	M39012/6880015 M39012/7080015	A	1.10 (27.94)

1/ Optional hardware part numbers are in parentheses.

2/ Mating connector part numbers are for reference only. All mating connectors may not be listed.

3/ Millimeters are in parentheses.

4/ These connectors have captivated center contacts.

5/ Connector bodies shall be gold-plated per MIL-G-45204, type II, class 1.

$\equiv$  The RG cables are specified with the basic number. The latest version of each cable shall be applicable.

\* Cable to be used when performing tests requiring cable except as in notes  $\emptyset$  and  $\Delta$ .

$\emptyset$  Cable to be used for the +200°C thermal shock tests.

$\Delta$  These are not 50-ohm cables, therefore, when attached to the specified connectors, VSWR, RF leakage and insertion loss are not applicable.

$\emptyset$  Caution is directed to the application of this cable above 400 MHz. Attenuation is tested only at 400 MHz. SRL and power handling capabilities are not stipulated herein.

TABLE IV. Group qualification and retention testing.

Group	Submission and retention of qualification of any of the following connectors <u>1/</u>	Qualifies the following connectors
I	M39012/67-0003	M39012/67-0003 M39012/67-0103 <u>2/</u>
II	M39012/67-0004	M39012/67-0004 M39012/67-0104 <u>2/</u>
III	M39012/6780008	M39012/6780008 M39012/6780013 <u>2/</u>
IV	M39012/6780009	M39012/6780009 M39012/6780010 M39012/6780014 <u>2/</u> M39012/6780015 <u>2/</u>
V	M39012/6780010	M39012/6780010 M39012/6780015 <u>2/</u>
VI	M39012/67-0011	M39012/67-0011 M39012/67-0016 <u>2/</u>
VII	M39012/67-0012	M39012/67-0012 M39012/67-0017 <u>2/</u>

1/ For qualification retention, where more than one part is listed in a group in this column, data may be supplied on any of those parts in order to retain qualification for those parts in the corresponding right hand column.

2/ Corrosion (salt spray) and contact resistance data must be submitted to DESC-EQP before qualification approval may be granted.

NOTE: If a connector manufacturer produces a connector which meets all the requirements for two or more connector part numbers (within the same series), the manufacturer may receive qualification approval for two or more connector part numbers by qualifying the one connector. It is not necessary that such connectors be in the same group. Each connector, however, must be marked with its own appropriate part number. For group qualification, the connectors must be of similar design. Qualification of connectors qualifies connectors of the same body material and finish only.

TABLE V. Cross-reference of part numbers.

Preferred part number M39012/67 <u>1/</u>	Substitute for part number or type designation
-0003	M39012/67-0001
-0004	M39012/67-0002
80008	M39012/67-0008, M39012/67-0005
80009	M39012/67-0009, M39012/67-0006
80010	M39012/67-0010, M39012/67-0007

1/ The new "B" part numbers will be required marking six months after the date of this specification. The previous part number may be used in the interim.

Revision letters are not used to denote changes due to the extensiveness of the changes.

## Custodians:

Army - CR  
Navy - EC  
Air Force - 85

## Preparing activity:

Army - CR

## Agent:

DLA - ES

## Review activities:

Army - EA, MI  
Navy - SH  
Air Force - 11, 17, 80, 99  
DLA - ES

(Project 5935-3553-1)

## User activities:

Army - AT, AV  
Navy - AS, MC, OS  
Air Force - 19