

SVH SERIES

NEC's SVH series solid tantalum capacitors have been developed for automotive application.

Compared to the conventional type (R series), the higher reliability and higher performance have been built in the same case size with NEC's original technologies.

FEATURES

The SVH-series has the highest level of reliability and performance in the tantalum chip capacitors as shown below.

- Damp Heat, Steady state : 85°C, 85% RH, 1000 hours
- Rapid Change of Temperature : -55°C to +125°C, 1000 cycles
- Resistance to Soldering Heat : 260°C, 10 sec (Fully Immersed to Solder)
- Failure Rate : 0.5 %/1000 hours (at 85°C, Rated Voltage Applied)

APPLICATIONS

- Automotive Electronics
- Other electronic equipment that requires high reliability and performance

OUTLINE DRAWINGS AND DIMENSIONS

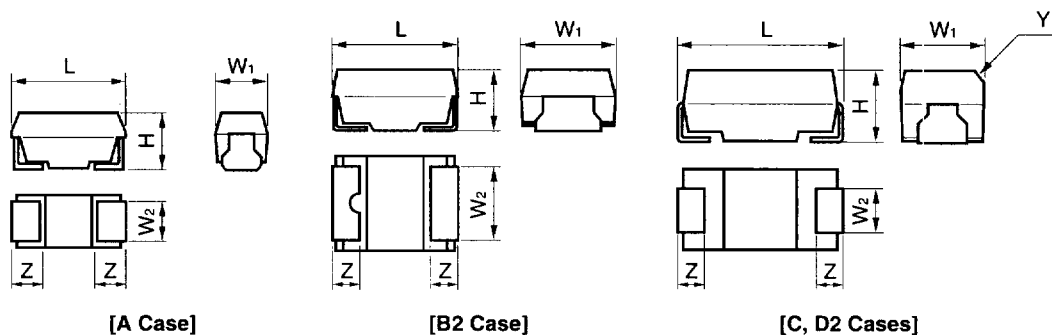

Unit : mm (inch)

Case Size	EIA Code	L	W ₁	W ₂	H	Z	Y
A	3216	3.2±0.2 (0.126±0.008)	1.6±0.2 (0.063±0.008)	1.2±0.1 (0.047±0.004)	1.6±0.2 (0.061±0.008)	0.8±0.3 (0.031±0.012)	—
B2	3528	3.2±0.2 (0.138±0.008)	2.8±0.2 (0.110±0.008)	2.3±0.1 (0.091±0.004)	1.9±0.2 (0.075±0.008)	0.8±0.3 (0.031±0.012)	—
C	6032	6.0±0.3 (0.236±0.012)	3.2±0.3 (0.126±0.012)	2.2±0.1 (0.087±0.004)	2.5±0.3 (0.098±0.012)	1.3±0.3 (0.051±0.012)	0.4C (0.016)
D2	—	5.8±0.3 (0.228±0.012)	4.6±0.2 (0.181±0.012)	2.4±0.1 (0.094±0.004)	3.2±0.3 (0.126±0.012)	1.3±0.3 (0.051±0.012)	—

MARKING

— Top View —

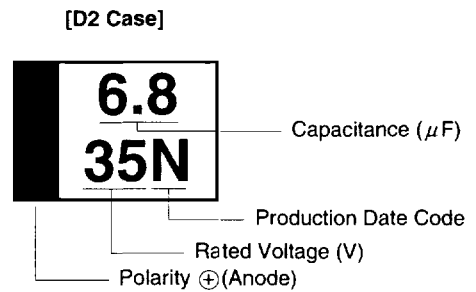
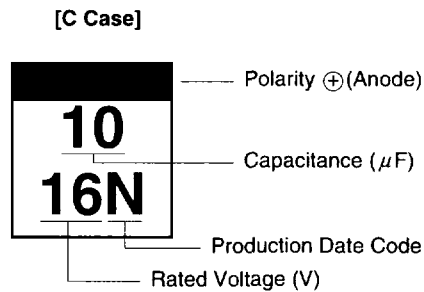
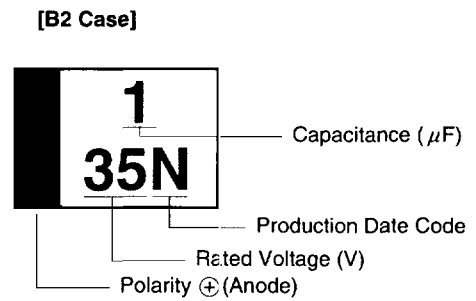
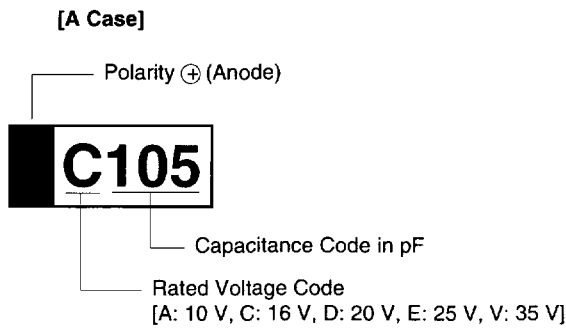

— Bottom View —
(for A Case)

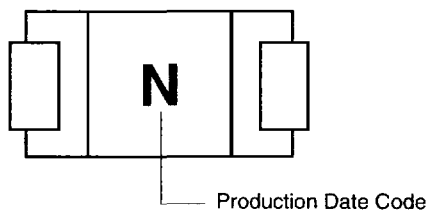

[Production Date Code]

Year \ Month	Jan.	Feb.	Mar.	Apr.	May	Jun.	Jul.	Aug.	Sep.	Oct.	Nov.	Dec.
1998	N	P	Q	R	S	T	U	V	W	X	Y	Z
1999	a	b	c	d	e	f	g	h	j	k	l	m
2000	n	p	q	r	s	t	u	v	w	x	y	z
2001	A	B	C	D	E	F	G	H	J	K	L	M

Date code will resume beginning in 2002.

PRODUCT LINE UP AND CASE SIZE

Rated voltage (V dc) Capacitance (μF)	10 V	16 V	20 V	25 V	35 V
0.1					A
0.15					A
0.22					A
0.33					A
0.47				A	B2
0.68			A		B2
1		A			B2
1.5		A		B2	C
2.2	A		B2		C
3.3		B2			C
4.7	B2			C	D2
6.8			C		D2
10		C		D2	
15	C		D2		
22		D2			
33	D2				

PART NUMBERING SYSTEM

- Bulk -

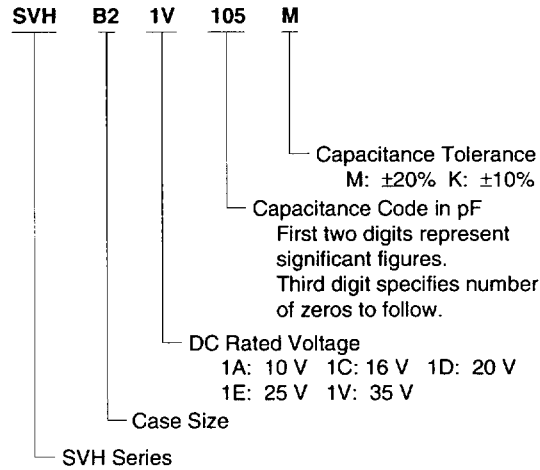

- Tape and Reel -

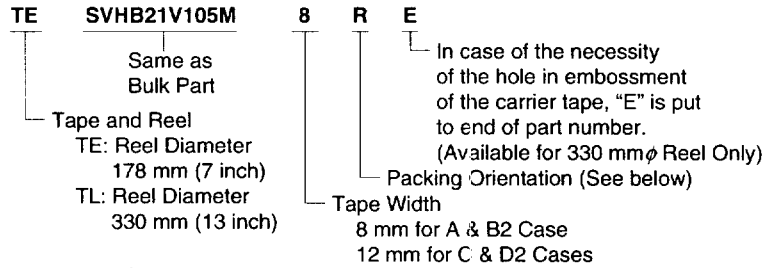

- Packing Orientation -

R: Orientation

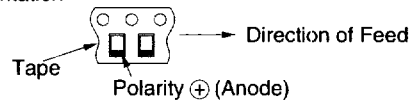

L: Orientation

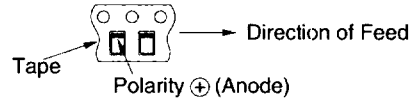

PERFORMANCE CHARACTERISTICS

Item		Specification					Test Method
Operating Temperature Range		-55 to +125°C					
Rated Voltage		10	16	20	25	35	Vdc Temperature: 85°C
Surge Voltage		13	20	26	33	46	Vdc Temperature: 85°C
Category Voltage		6.3	10	13	16	22	Vdc Temperature: 125°C (*1)
Capacitance Range		0.1 to 33 μF					Frequency: 120 Hz
Capacitance Tolerance		±20% (±10%)					
Leakage Current (L.C.)		0.01 CV (μA) or 0.5 μA whichever is greater					5 min, after rated voltage applied
Tangent of Loss Angle (tan δ)		0.1 to 4.7 μF: 0.04 max. 6.8 to 33 μF: 0.06 max.					Frequency: 120 Hz
Surge Voltage Test		ΔC/C : ±5% tan δ : Initial Requirement L.C. : Initial Requirement					Temperature: 8.5°C Surge Voltage for 30 sec. Series Resistance: 1 kΩ Discharge Voltage for 5 min. 30 sec. 1000 cycles
Characteristics at High and Low Temperature	Temp.	-55°C		+85°C		+125°C	Step 1: 20°C Step 2: -55°C Step 3: 20°C Step 4: 85°C Step 5: 125°C Step 6: 20°C
	ΔC/C	0, -12%		+12, 0%		+15, 0%	
	tan δ	0.1 to 4.7 μF: 0.08 max. 6.8 to 33 μF: 0.10 max.		Initial Requirement		0.1 to 4.7 μF: 0.06 max. 6.8 to 33 μF: 0.08 max.	
	L.C.	-		0.1 CV or 5 μA whichever is greater		0.125 CV or 6.25 μA whichever is greater	
Rapid Change of Temperature		ΔC/C : ±10% tan δ : Initial Requirement L.C. : Initial Requirement					-55 to +125°C 1000 cycles
Resistance to Soldering Heat		ΔC/C : ±5% tan δ : Initial Requirement L.C. : Initial Requirement					Fully immersion to solder, 260°C, 10 sec.
Damp Heat, Steady State		ΔC/C : 10% tan δ : Initial Requirement × 1.5 L.C. : Initial Requirement					Temperature: 85°C 85% RH 1000 hours
Endurance		ΔC/C : ±10% tan δ : Initial Requirement L.C. : Initial Requirement × 1.25					Temperature: 85°C Rated Voltage Applied Temperature: 125°C Category Voltage Applied 2000 hours
Failure Rate		λ ₀ = 0.5 %/1000H					

LEGEND

CV : Product of capacitance in μF and voltage in V
 ΔC/C: Capacitance Change Ratio

*1: Category voltage at 85°C or more is calculated by following expression.

$$U_T = U_R - \frac{U_R - U_C}{40} (T - 85)$$

U_R : Rated Voltage
 U_C : Category Voltage at 125°C

DC Rated Voltage @85°C (125°C) Vdc	Capacitance @20°C, 120 Hz μF	Case Size	Part Number	Leakage Current @20°C μA Max.	tan δ @20°C, 120 Hz % Max.
10 (6.3)	2.2	A	SVHA1A225M	0.5	4
	4.7	B2	SVHB21A475M	0.5	4
	15	C	SVHC1A156M	1.5	6
	33	D2	SVHD21A335M	3.3	6
16 (10)	1	A	SVHA1C105M	0.5	4
	1.5	A	SVHA1C155M	0.5	4
	3.3	B2	SVHB21C335M	0.5	4
	10	C	SVHC1A106M	1.6	6
	22	D2	SVHD21A226M	3.5	6
20 (13)	0.68	A	SVHA1D684M	0.5	4
	2.2	B2	SVHB21D225M	0.5	4
	6.8	C	SVHC1D685M	1.4	6
	15	D2	SVHD21D156M	3.0	6
25 (16)	0.47	A	SVHA1E474M	0.5	4
	1.5	B2	SVHB21E155M	0.5	4
	4.7	C	SVHC1E475M	1.1	4
	10	D2	SVHD21E106M	2.5	6
35 (22)	0.1	A	SVHA1V104M	0.5	4
	0.15	A	SVHA1V154M	0.5	4
	0.22	A	SVHA1V224M	0.5	4
	0.33	A	SVHA1V334M	0.5	4
	0.47	B2	SVHB21V474M	0.5	4
	0.68	B2	SVHB21V684M	0.5	4
	1	B2	SVHB21V105M	0.5	4
	1.5	C	SVHC1V155M	0.5	4
	2.2	C	SVHC1V225M	0.7	4
	3.3	C	SVHC1V335M	1.2	4
	4.7	D2	SVHD21V475M	1.6	4
	6.8	D2	SVHD21V685M	2.3	6

CHARACTERISTICS DATA

Rapid Change of Temperature (-55 to +125°C)

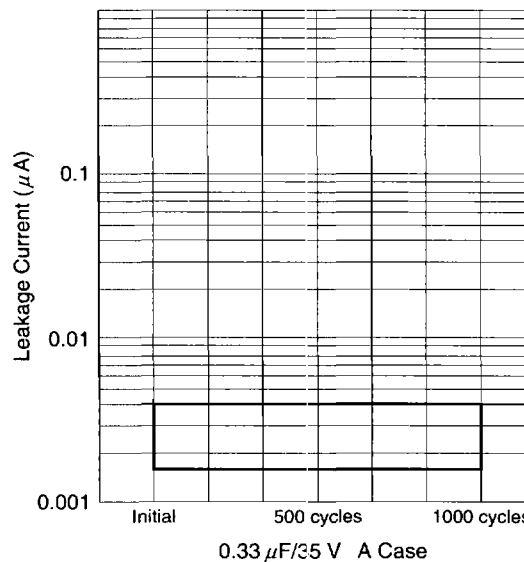
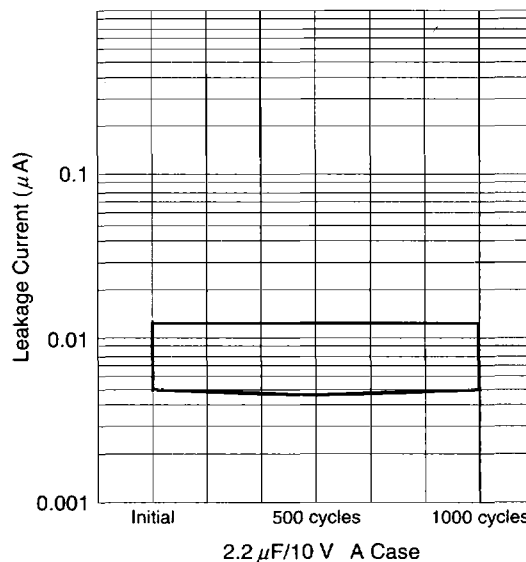
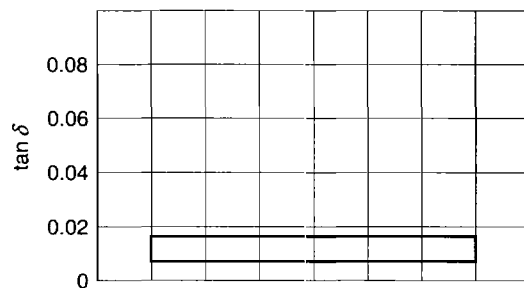
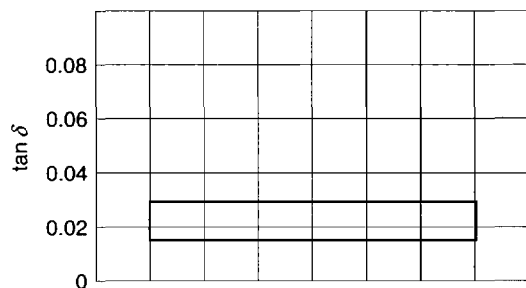
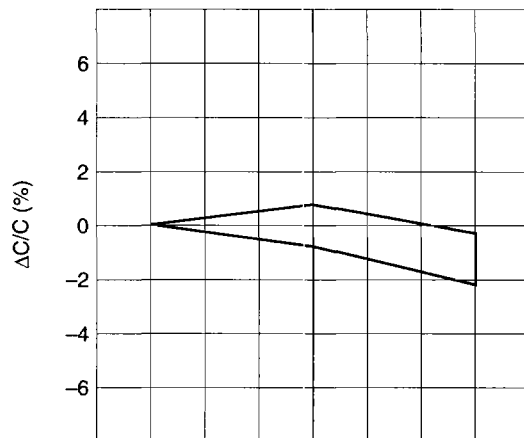
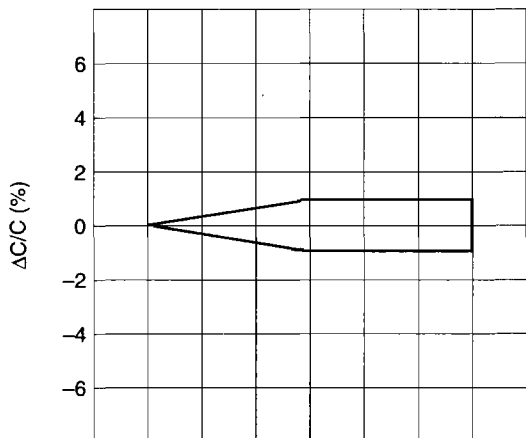

Rapid Change of Temperature (-55 to +125°C)

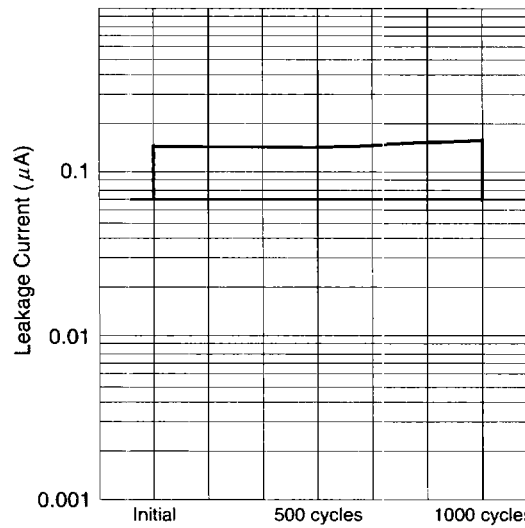
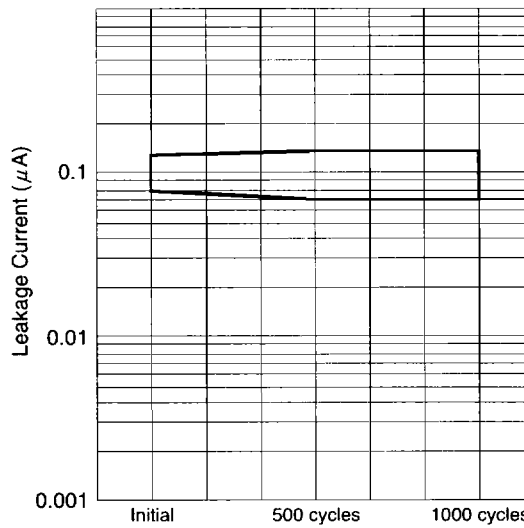
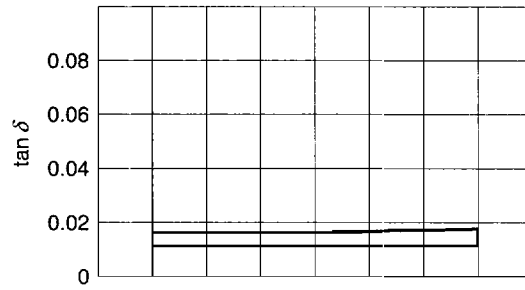
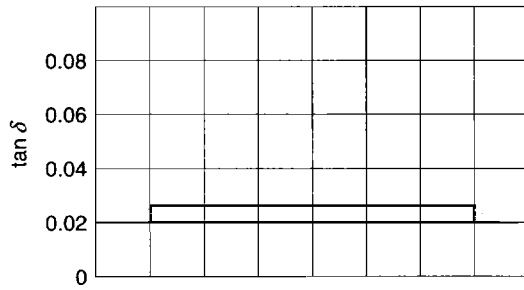
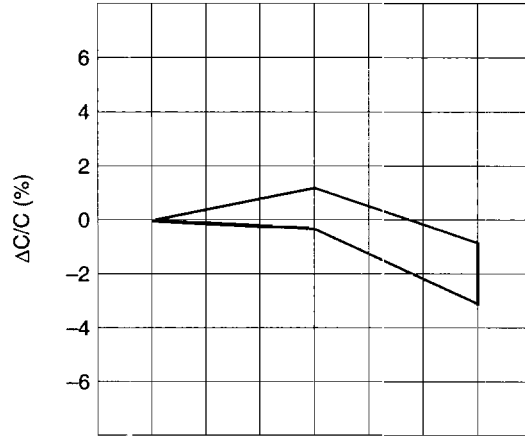
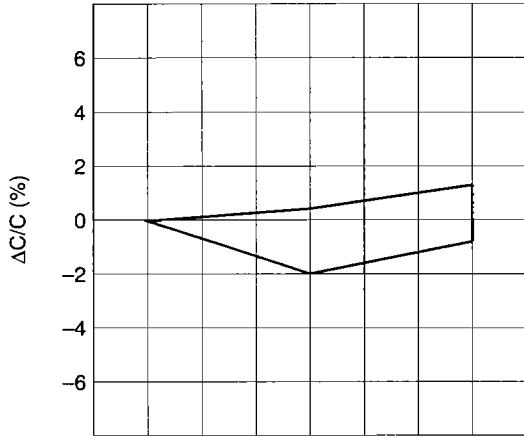

33 μF/10 V D2 Case

6.8 μF/35 V D2 Case

Damp Heat, Steady State (85°C, 85% RH)

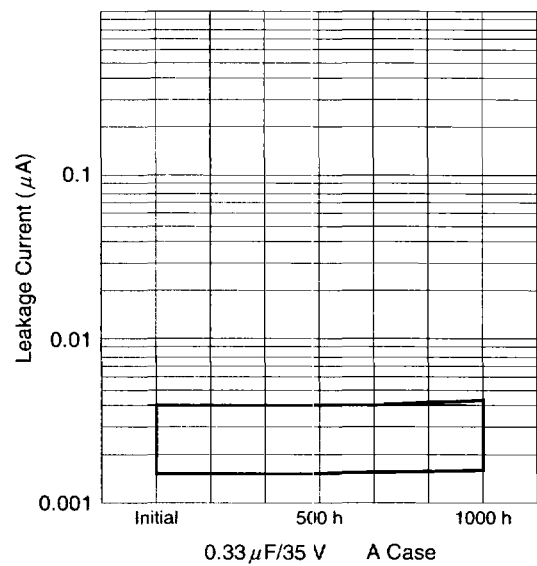
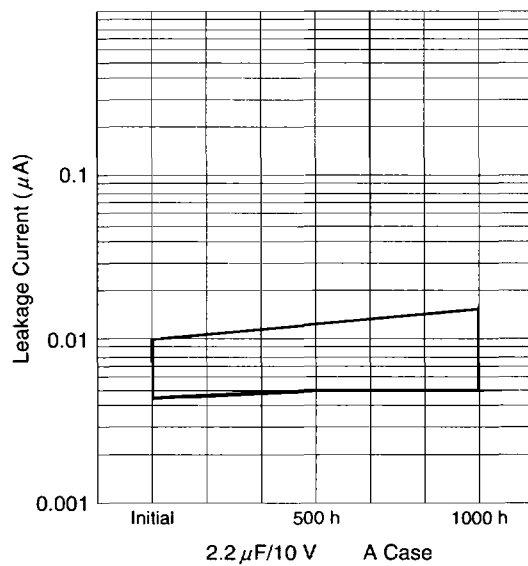
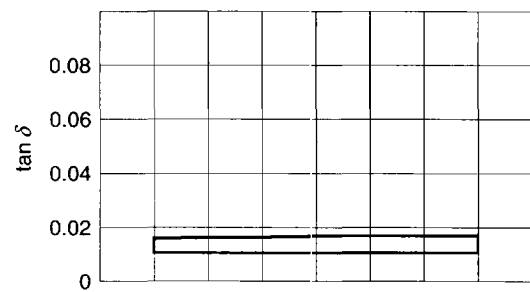
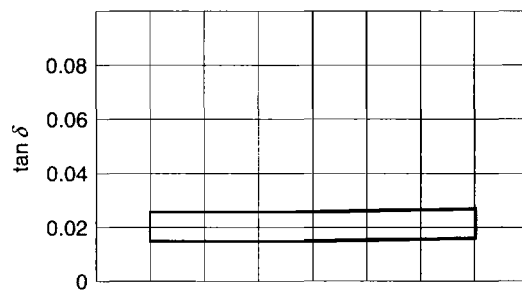
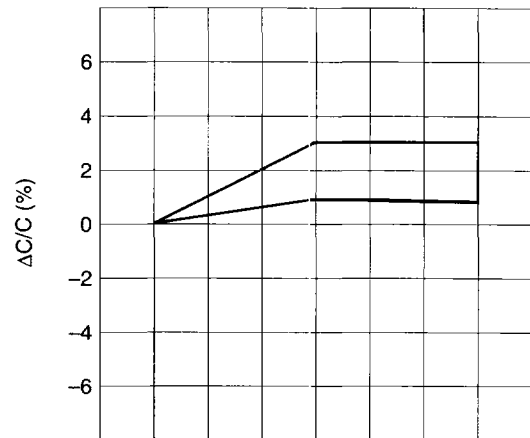
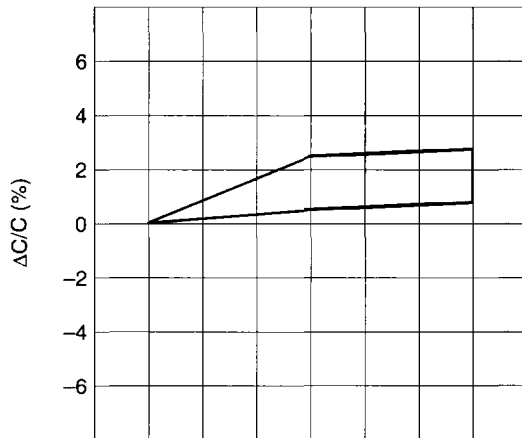

Damp Heat, Steady State (85°C, 85% RH)

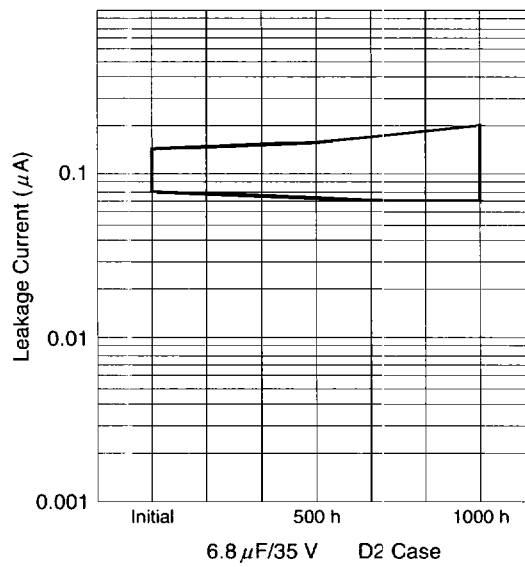
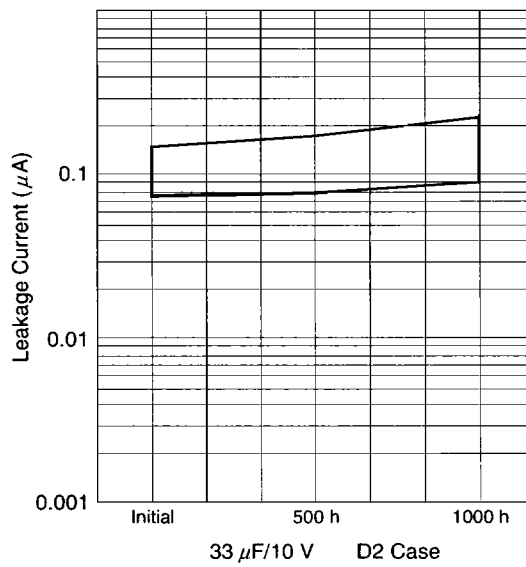
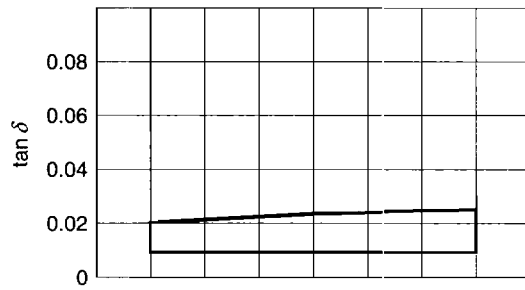
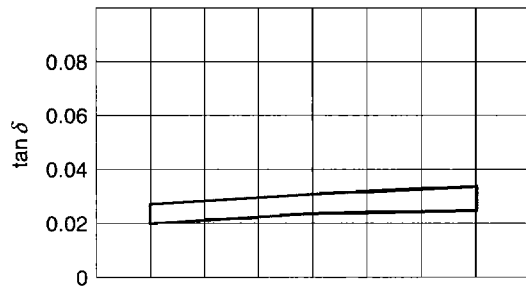
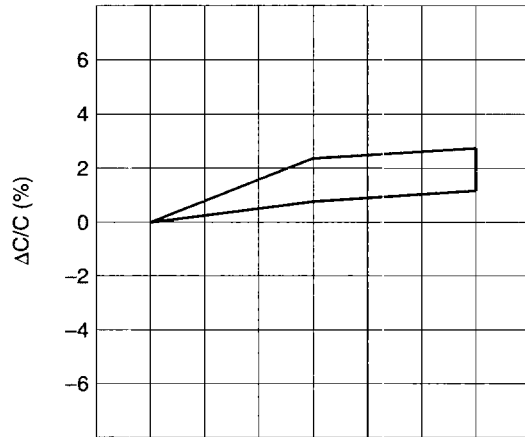
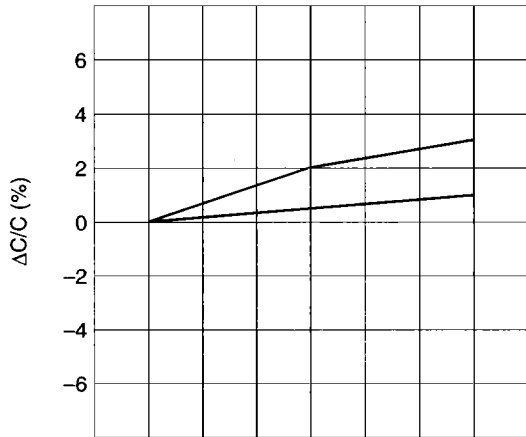

Endurance (85°C, Rated Voltage × 1.3 Applied)
(Reference Data)

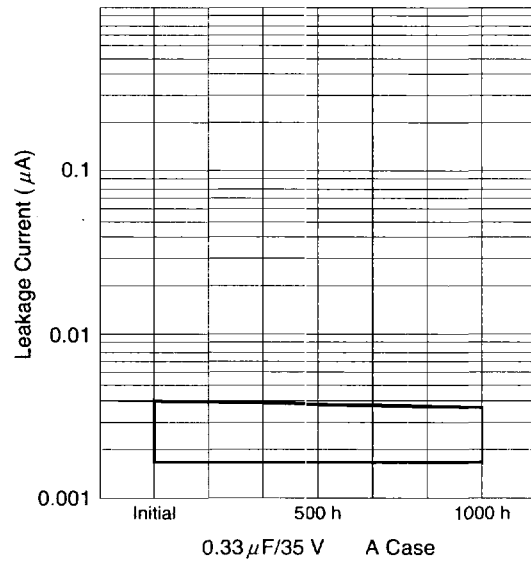
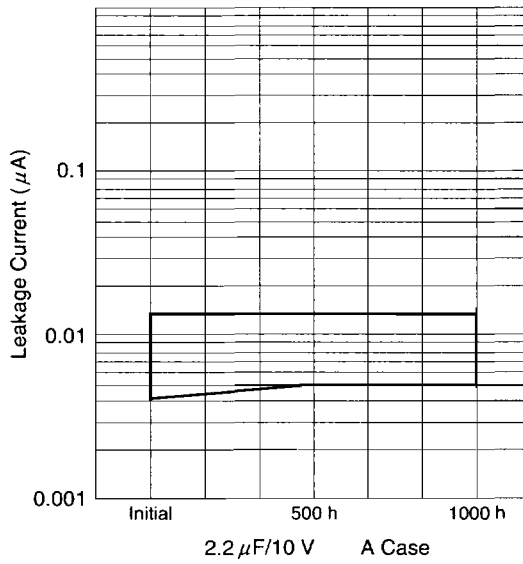
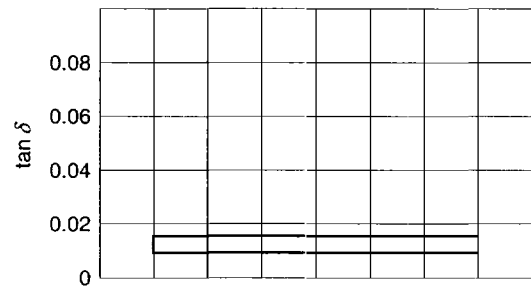
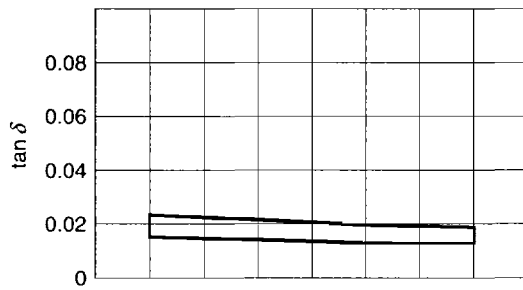
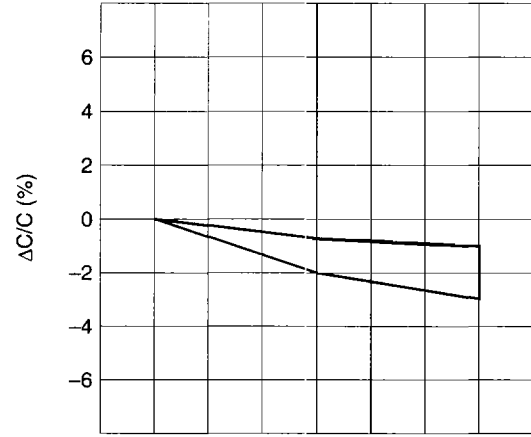
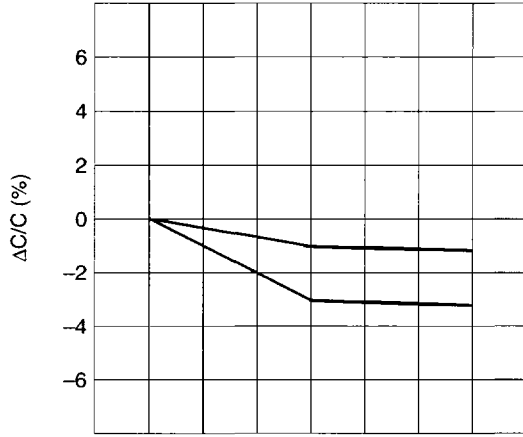

Impedance – Frequency Characteristics

