

HALO Electronics has developed this standard series of extended temperature range, 12 pin SMD Line Interface Modules to meet the isolation and impedance matching requirements for T1, E1 CEPT and PRI ISDN applications. UL60950 and EN60950 recognized. Non-standard designs are also available.

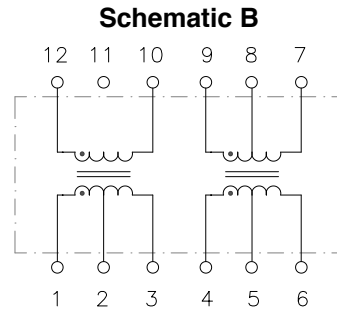
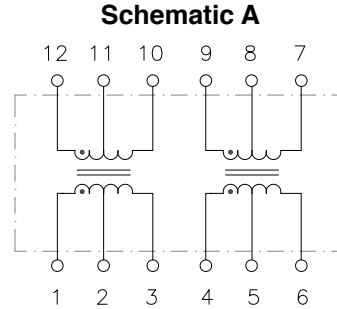
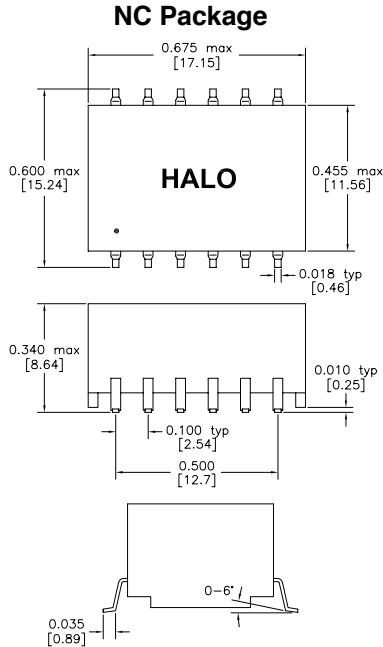

Electrical Specifications @ 25°C

Isolation Voltage:	1,500 Vrms
PRI OCL:	1.5mH Typ.
Leakage Inductance:	0.5µH Max.
PRI DCR:	0.9Ω Max.
Crosstalk (0.1- 10 MHz):	-60dB Typ.
Temperature Range:	(-40°C to +85°C)

Patented Construction

US Pat Nbrs:	5,656,985	6,297,721 B1
	6,297,720 B1	6,320,489 B1
	6,344,785 B1	6,662,431 B1

Part Number	Schematic	Turns Ratio PRI : SEC (±2%)	Cw/w (pF max)	Primary Pins
TG04-1505NCRL	A	1CT:1CT & 1CT:1CT	35	1-3 & 4-6
TG23-1505NCRL	A	1CT:2.42CT & 1CT:2.42CT	40	1-3 & 4-6
TG24-S001NCRL	A	1CT:1.36CT & 1CT:1.36CT	40	12-10 & 4-6
TG26-1505NCRL	A	1CT:2CT & 1CT:2CT	35	12-10 & 4-6
TG27-1505NCRL	A	1CT:2CT & 1CT:1.36CT	35	12-10 & 4-6
TG28-1505NCRL	A	1CT:1CT & 1CT : 1.36CT	35	12-10 & 4-6
TG35-1505NCRL	A	1CT:1.15CT & 1CT:1CT	35	12-10 & 4-6
TG38-1505NCRL	A	1CT:1.15CT & 1CT:1.15CT	35	1-3 & 4-6
TG42-1505NCRL	A	1CT:1.41CT & 1CT:1.41CT	40	12-10 & 4-6
TG63-1505NCRL	B	1:1.15CT & 1CT:2CT	35	12-10 & 4-6
TG64-1505NCRL	A	1CT:1:1.26 & 1CT:2CT	35	12-10 & 4-6
TG74-1505NCRL	A	1CT:1CT & 1CT : 2CT	35	12-10 & 4-6