

**80 OUTPUT BIT MAP LCD EXTENSION DRIVER****■ GENERAL DESCRIPTION**

The NJU6453A is a 80 output bit map LCD extension driver to display graphics or characters combine with NJU6452A.

It contains 2,560 bit display data RAM, microprocessor interface circuits, instruction decoder, and 80-segment driver.

The bit image display data sent from 8- or 16-bit MPU are stored in the display data RAM and drives segment of Dot Matrix LCD Panel synchronized with the NJU6452A common timing.

When the NJU6453A combine with the NJU6452A, the display capacity expand to 16 x 141 dots of graphics or 28-character 2-line with icon of 5 x 8 dots character display.

Furthermore, the wide operating voltage and low current consumption are useful apply to the battery operated items.

**■ PACKAGE OUTLINE**

NJU6453AC

**5****■ FEATURES**

- Direct Correspondence between Display Data RAM and LCD Pixel
- Display Data RAM - 2,560 bits 80 x 8 x 4
- Direct Interface with 8- or 16-bit MPU  
(Both of 68 and 80 type MPU can connect directly)
- Extension Driver of NJU6452A
- Read Out From the Display Data RAM
- 80-segment Driver
- Programmable Duty Ratio ; 1/16 or 1/32 Duty
- Useful Instruction Set  
Display Data Read/Write, Display ON/OFF Cont, Display Data RAM Address Set, Status Read, Display Starting Line Set, Static Drive ON/OFF, Duty Ratio Setting, and Read Modify Write,
- Low Power Consumption
- Operating Voltage --- 2.4V~6.0V
- LCD Driving Voltage --- 3.0V~13.5V
- Package Outline --- Chip
- C-MOS Technology



■ PAD LOCATION

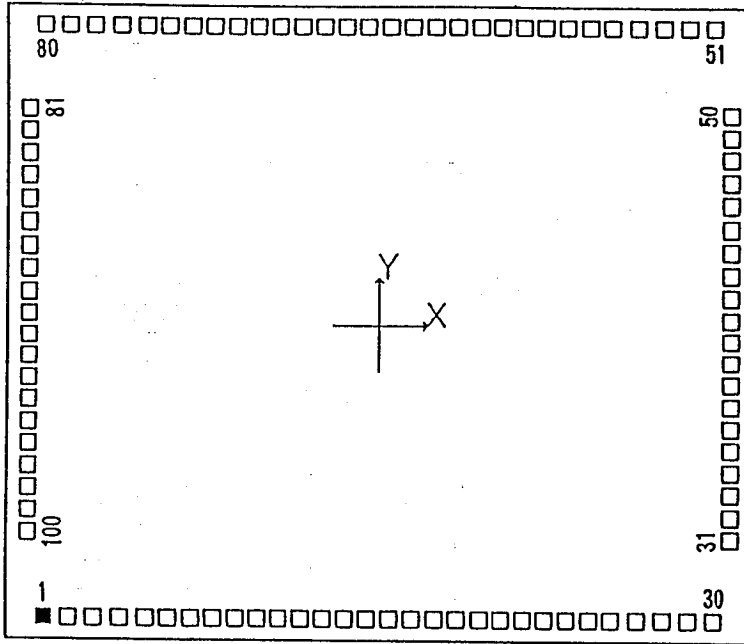

Chip Center X=0um, Y=0um  
Chip Size 4860um x 4160um  
Chip Thickness 400um ± 30um  
Pad Size 92um x 92um



■ PAD COORDINATES

Chip Size 4860um x 4160um(Chip Center X=0um,Y=0um)

No.	Terminal Name	X=(um)	Y=(um)
1	SEG <sub>71</sub>	-2130	-1865
2	SEG <sub>70</sub>	-1970	-1865
3	SEG <sub>69</sub>	-1810	-1865
4	SEG <sub>68</sub>	-1650	-1865
5	SEG <sub>67</sub>	-1490	-1865
6	SEG <sub>66</sub>	-1330	-1865
7	SEG <sub>65</sub>	-1190	-1865
8	SEG <sub>64</sub>	-1050	-1865
9	SEG <sub>63</sub>	- 910	-1865
10	SEG <sub>62</sub>	- 770	-1865
11	SEG <sub>61</sub>	- 630	-1865
12	SEG <sub>60</sub>	- 490	-1865
13	SEG <sub>59</sub>	- 350	-1865
14	SEG <sub>58</sub>	- 210	-1865
15	SEG <sub>57</sub>	- 70	-1865
16	SEG <sub>56</sub>	70	-1865
17	SEG <sub>55</sub>	210	-1865
18	SEG <sub>54</sub>	350	-1865
19	SEG <sub>53</sub>	490	-1865
20	SEG <sub>52</sub>	630	-1865
21	SEG <sub>51</sub>	770	-1865
22	SEG <sub>50</sub>	910	-1865
23	SEG <sub>49</sub>	1050	-1865
24	SEG <sub>48</sub>	1190	-1865
25	SEG <sub>47</sub>	1330	-1865
26	SEG <sub>46</sub>	1490	-1865
27	SEG <sub>45</sub>	1650	-1865
28	SEG <sub>44</sub>	1810	-1865
29	SEG <sub>43</sub>	1970	-1865
30	SEG <sub>42</sub>	2130	-1865
31	SEG <sub>41</sub>	2213	-1354
32	SEG <sub>40</sub>	2213	-1214
33	SEG <sub>39</sub>	2213	-1074
34	SEG <sub>38</sub>	2213	- 934
35	SEG <sub>37</sub>	2213	- 794
36	SEG <sub>36</sub>	2213	- 654
37	SEG <sub>35</sub>	2213	- 514
38	SEG <sub>34</sub>	2213	- 374
39	SEG <sub>33</sub>	2213	- 234
40	SEG <sub>32</sub>	2213	- 94
41	SEG <sub>31</sub>	2213	46
42	SEG <sub>30</sub>	2213	186
43	SEG <sub>29</sub>	2213	326
44	SEG <sub>28</sub>	2213	466
45	SEG <sub>27</sub>	2213	606
46	SEG <sub>26</sub>	2213	746
47	SEG <sub>25</sub>	2213	886
48	SEG <sub>24</sub>	2213	1026
49	SEG <sub>23</sub>	2213	1166
50	SEG <sub>22</sub>	2213	1306

No.	Terminal Name	X=(um)	Y=(um)
51	SEG <sub>21</sub>	2130	1865
52	SEG <sub>20</sub>	1970	1865
53	SEG <sub>19</sub>	1810	1865
54	SEG <sub>18</sub>	1650	1865
55	SEG <sub>17</sub>	1490	1865
56	SEG <sub>16</sub>	1330	1865
57	SEG <sub>15</sub>	1190	1865
58	SEG <sub>14</sub>	1050	1865
59	SEG <sub>13</sub>	910	1865
60	SEG <sub>12</sub>	770	1865
61	SEG <sub>11</sub>	630	1865
62	SEG <sub>10</sub>	490	1865
63	SEG <sub>9</sub>	350	1865
64	SEG <sub>8</sub>	210	1865
65	SEG <sub>7</sub>	70	1865
66	SEG <sub>6</sub>	- 70	1865
67	SEG <sub>5</sub>	- 210	1865
68	SEG <sub>4</sub>	- 350	1865
69	SEG <sub>3</sub>	- 490	1865
70	SEG <sub>2</sub>	- 630	1865
71	SEG <sub>1</sub>	- 770	1865
72	SEG <sub>0</sub>	- 910	1865
73	A <sub>0</sub>	-1050	1865
74	CS	-1190	1865
75	CL	-1330	1865
76	E	-1490	1865
77	R/W	-1650	1865
78	V <sub>SS</sub>	-1810	1865
79	DB <sub>0</sub>	-1970	1865
80	DB <sub>1</sub>	-2130	1865
81	DB <sub>2</sub>	-2213	1330
82	DB <sub>3</sub>	-2213	1190
83	DB <sub>4</sub>	-2213	1050
84	DB <sub>5</sub>	-2213	910
85	DB <sub>6</sub>	-2213	770
86	DB <sub>7</sub>	-2213	630
87	V <sub>DD</sub>	-2213	490
88	RST	-2213	350
89	FR	-2213	210
90	V <sub>5</sub>	-2213	70
91	V <sub>3</sub>	-2213	- 70
92	V <sub>2</sub>	-2213	- 210
93	SEG <sub>79</sub>	-2213	- 350
94	SEG <sub>78</sub>	-2213	- 490
95	SEG <sub>77</sub>	-2213	- 630
96	SEG <sub>76</sub>	-2213	- 770
97	SEG <sub>75</sub>	-2213	- 910
98	SEG <sub>74</sub>	-2213	-1050
99	SEG <sub>73</sub>	-2213	-1190
100	SEG <sub>72</sub>	-2213	-1330

\* Pad Size 92um x 92um

5

**■ TERMINAL DISCRIPTION**

PAD No.	SYMBOL	FUNCTION															
87	V <sub>DD</sub>	Power Supply : V <sub>DD</sub> = +5V															
78	V <sub>SS</sub>	GND : V <sub>SS</sub> = 0V															
90, 91, 92	V <sub>5</sub> , V <sub>3</sub> , V <sub>2</sub>	LCD Driving Voltage Supplying Terminal. Following relation must be maintained. V <sub>DD</sub> ≥ V <sub>2</sub> ≥ V <sub>3</sub> ≥ V <sub>5</sub>															
74	CS	Chip Select Signal Input Terminal. Normally input the decoded signal of Address Bus Signal. Active "L".															
75	CL	Display data Latch Signal Input Terminal. The Line Counter also count up by this signal rising timing. The synchronized signal of the NJU6452A is required.															
76	E <u>(RD)</u>	<When connect to the 68 type MPU> Connect to Enable Clock input Terminal of 68 type MPU. Active "H". <When connect to the 80 type MPU> Connect to RD Signal Input terminal of 80 type MPU. Active "L". During this terminal is "L", the Data Bus is output state.															
77	R/W <u>(WR)</u>	<When connect to the 68 type MPU> Connect to READ/WRITE Control Signal Input Terminal of 68 type MPU. <table border="1" style="margin-left: 20px;"> <tr> <td>R/W</td> <td>H</td> <td>L</td> </tr> <tr> <td>Status</td> <td>Read</td> <td>Write</td> </tr> </table> <When connect to the 80 type MPU> Connect to WR signal connecting terminal of 80 type MPU. Active "L". The data on the Data Bus is fetch at the rising edge of this signal.	R/W	H	L	Status	Read	Write									
R/W	H	L															
Status	Read	Write															
73	A0	Connect to the Address Bus of MPU. The data on the D <sub>0</sub> ~D <sub>7</sub> is distinguished between Display Data and Instruction by this signal. <table border="1" style="margin-left: 20px;"> <tr> <td>A0</td> <td>H</td> <td>L</td> </tr> <tr> <td>Data</td> <td>Display data</td> <td>Instruction</td> </tr> </table>	A0	H	L	Data	Display data	Instruction									
A0	H	L															
Data	Display data	Instruction															
79~86	D <sub>0</sub> ~D <sub>7</sub>	Tri-state bilateral Data Bus of MPU. The data transmission between 8- or 16-bit MPU and NJU6451A is executed by this Bus.															
89	FR	Alternating signal for LCD Driving input terminal.															
93~100, 1~72	SEG <sub>79</sub> ~SEG <sub>0</sub>	Segment output terminal. One output level out of V <sub>DD</sub> , V <sub>2</sub> , V <sub>3</sub> , V <sub>5</sub> is selected by combination of FR and data of Display RAM. <table border="1" style="margin-left: 20px;"> <tr> <td>FR</td> <td colspan="2">H</td> <td colspan="2">L</td> </tr> <tr> <td>Data</td> <td>H</td> <td>L</td> <td>H</td> <td>L</td> </tr> <tr> <td>Output</td> <td>V<sub>DD</sub></td> <td>V<sub>2</sub></td> <td>V<sub>5</sub></td> <td>V<sub>3</sub></td> </tr> </table>	FR	H		L		Data	H	L	H	L	Output	V <sub>DD</sub>	V <sub>2</sub>	V <sub>5</sub>	V <sub>3</sub>
FR	H		L														
Data	H	L	H	L													
Output	V <sub>DD</sub>	V <sub>2</sub>	V <sub>5</sub>	V <sub>3</sub>													
88	RST	Reset and interface type select terminal. The reset operation is performed by rise or fall edge of this signal. The input level after initialization selects the interface type of 68 or 80 type of MPU. <table border="1" style="margin-left: 20px;"> <tr> <td>MPU</td> <td>Edge</td> <td>Input Level after Initialization</td> </tr> <tr> <td>68 Type</td> <td>Rise</td> <td>H</td> </tr> <tr> <td>80 Type</td> <td>Fall</td> <td>L</td> </tr> </table>	MPU	Edge	Input Level after Initialization	68 Type	Rise	H	80 Type	Fall	L						
MPU	Edge	Input Level after Initialization															
68 Type	Rise	H															
80 Type	Fall	L															

**■ Functional Description**
**(1) Description for each blocks**
**(1-1) Busy Flag (BF)**

When the internal circuits are in the operation mode, the busy flag(BF) is "1", and any instruction except the status read are inhibited.

The busy flag is output at D<sub>7</sub> terminal when status read instruction is executed.

If enough cycle time over than t<sub>ovc</sub> is kept, no need to check the busy flag.

**(1-2) Display Start Line Register**

The Display Start Line Register is a pointer register which indicate the address in the Display Data RAM corresponded with COM<sub>0</sub> (normally it display the top line in the LCD Panel).

This register can use for scroll the screen, change the display page and so on.

The Display Start Line instruction set the display start address of the Display Data RAM represented in 5-bit to this register.

**(1-3) Line Counter**

The Display Start Address stored in the Display Start Line Register is set to the Line Counter when the FR signal out from the NJU6452A is changing.

The Line Counter count up by synchronizing common signal out from NJU6452A and generate the line address which addressing the read out line of Display Data RAM.

**(1-4) Column Address Counter**

The column address counter is 7-bit presettable counter which addressing the column address as shown as Fig. 1.

This counter increments "1" up to 50H when the Display Data Read/Write instruction is executed. The count up is stop at 50H (over 50H is non existing address) automatically by the count lock function.

Furthermore, this counter is independent with the Page Register.

**(1-5) Page Register**

This register gives page address of Display Data RAM as shown Fig. 1.

When the MPU access the data by changing the page, the page address set instruction is required.

**(1-6) Display Data RAM**

Display Data Ram consist of 2,560 bits stores the bit image display data (each bit correspond to the each pixel so called bit map method). This RAM and MPU are operating independently, therefore, there is no influence by the unsynchronize rewriting.

The each bit in the Display Data RAM correspond to the each dot of the LCD panel.

On = "1"

Off = "0"

The relation between column address and segment output can inverse by the Address Inverse Instruction ADC as shown Fig. 1.

**(1-7) Timing Generator**

This Generator generates the count up signal of Line Counter by the CL clock signal and pre-set signal for the Line Counter by the frame signal.

The LCD driving duty is dertermined by the CL clock and frame signal FR.

**(1-8) Display Data Latch**

Display Data Latch stores 80-bit of one line display data for each common cycle which read out from the Display Data RAM temporary and transfer this data to the LCD Driver.

The Display On/Off and Static Drive On/Off controls the latched data only, therefore, the data in the Display Data RAM is no change and keep on remaining.

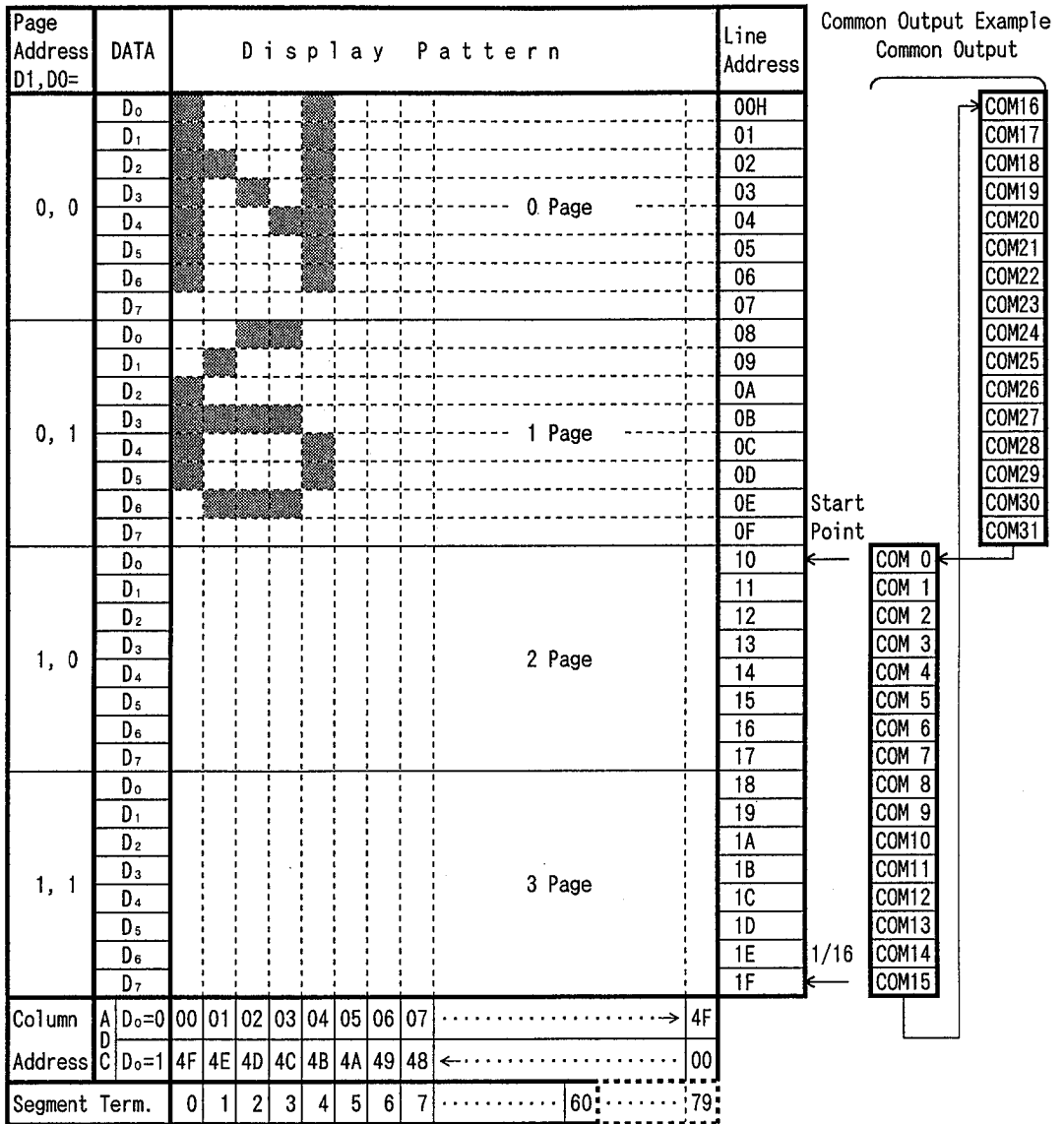

Fig. 1. Correspondence with Display Data RAM and address (For example the display start line is 10th and 1/32 duty)

## (1-9) Segment Driver

The 80-Segment Driver outputs the 4-level of LCD driving voltage.

The output waveform is determined by the combination of the data in the Display Data Latch, Common Timing Generator and FR signal

## (1-10) Display Timing Generator

This Generator generates the timing signal for the display system by combination of the master clock and Frame Driving Signal FR. The Frame Driving Signal FR has a function to generate the 2 frame alternative driving method waveform for the LCD panel, and synchronizing the line counter and common timing generator to the NJU6452A. Therefore, the FR signal must be 50% duty ratio clock signal which synchronized with the frame signal.

## (1-11) Reset Circuits

The NJU6453A performs following initialization by detecting the rising or falling edge of the  $\overline{RST}$  input after the power turns on.

## Initialization

- ① Display Off
- ② Set the 1st line to the Display Start Register
- ③ Static Drive Off
- ④ Set the address "0" to the Column Address Counter
- ⑤ Set the page "3" to the Page Address Register
- ⑥ Select the 1/32 duty
- ⑦ Select the ADC : Counterclockwise output  
(ADC instruction  $D_0 = "0"$ , ADC status flag "1")
- ⑧ Read Modify Write Mode Off

The  $\overline{RST}$  terminal input level is used to select the interface of 80 or 68 type MPU as shown in Table. 2. Therefore, the "H" level input through the inverter is required when connecting the 80 type MPU, and "L" level input is required when connecting the 68 type MPU as shown in application circuits 1.

The  $\overline{RST}$  terminal must be connect to the Reset Terminal of MPU and reset at same time with it. The dead-lock may occur if the no initialization by the  $\overline{RST}$  terminal when the power terns on. By the RESET instruction, the initialization of ② and ⑤ mentioned above are executed.

## (2) Instruction

The NJU6453A distinguish the signal on the data bus by combination of A0 and R/W( $\overline{RD}$ ,  $\overline{WR}$ ).

Normally, the busy check is not required as the NJU6453A is operating so first because of the decode of the instruction and execution are performs only depend on the internal timing which not depend on the external clock.

The Table. 1 shows the instruction codes of the NJU6453A.

Table 1. Instruction Code

Instruction	C o d e											Description
	A0	$\overline{RD}$	$\overline{WR}$	D <sub>7</sub>	D <sub>6</sub>	D <sub>5</sub>	D <sub>4</sub>	D <sub>3</sub>	D <sub>2</sub>	D <sub>1</sub>	D <sub>0</sub>	
Display On / Off	0	1	0	1	0	1	0	1	1	1	0/1	Whole Display On/Off. 1:On,0:Off(Power Save mode if the static Drive On)
Display Start Line	0	1	0	1	1	0	Display Start Address (1~31)				Determine the Display Line correspond to the COM <sub>0</sub> .	
Page Address Set	0	1	0	1	0	1	1	1	0	Page (0~3)		Set the Page of Disp. Data RAM to the Page Register.
Column Address Set	0	1	0	0	Column Address (0~79)						Set the Column Address of Display Data RAM to the Column Register.	
Status Read	0	0	1	B U S Y	A D C	O N / O F F	R E S E T	0	0	0	0	Read the status. BUSY 1:Working 0:Ready ADC 1:Clockwise Output 0:Counterclockwise ON/OFF1:Disp Off 0:Disp On RESET 1:Reset 0:Normal
Write Display Data	1	1	0	Write Data							Write the data to the Display Data RAM.	Access the predetermined address of the Display Data RAM. The Column address increment "1" after read or write.
Read Display Data	1	0	1	Read Data							Read the data from the Display Data RAM.	
ADC Select	0	1	0	1	0	1	0	0	0	0	0/1	Determine the clockwise or counterclockwise reading of the Display Data RAM. 0:Clockwise Output 1:Counterclockwise Output
Static Drive On / Off	0	1	0	1	0	1	0	0	1	0	0/1	Select the Dynamic or Static Driving. 1:Static Driving (Power Saving) 0:Dynamic Driving
Duty Ratio Select	0	1	0	1	0	1	0	1	0	0	0/1	Select the duty ratio. 1:1/32 Duty 0:1/16 Duty
Read Modify Write	0	1	0	1	1	1	0	0	0	0	0	Increment the Column Address register when writing but no-change when reading.
End	0	1	0	1	1	1	0	1	1	1	0	Release from the Read Modify Write Mode.
Reset	0	1	0	1	1	1	0	0	0	1	0	Set the Display Start Line Register to 1st line, Page Add. Register to "3".
Power Save (Dual Command)	0	1	0	1	0	1	0	1	1	1	0	Set the power save mode by selecting Display Off and Static Driving On.
	0	1	0	1	0	1	0	0	1	0	1	

(3) Explanation of Instruction Code.

(a) Display On/Off

This instruction executes whole display On/Off no relation with the data in the Display Data RAM and internal conditions.

	R/W										
	A0	$\overline{\text{RD}}$	$\overline{\text{WR}}$	D <sub>7</sub>	D <sub>6</sub>	D <sub>5</sub>	D <sub>4</sub>	D <sub>3</sub>	D <sub>2</sub>	D <sub>1</sub>	D <sub>0</sub>
Code	0	1	0	1	0	1	0	1	1	1	D

D 0 : Display On  
 1 : Display Off

When the static driving mode is selected (static drive On) in display Off status, the internal circuits put on the power save mode.

(b) Display Start Line

This instruction set the line address as shown Fig. 1. The selected line in the Display Data RAM correspond to the COM<sub>0</sub> which display at the top of LCD panel.

The display area is set automatically from the selected line to the line which increased the number of duty ratio.

Therefore, the smooth scroll for vertical direction by changing the start line address one by one or page switching are available by this instruction.

	R/W										
	A0	$\overline{\text{RD}}$	$\overline{\text{WR}}$	D <sub>7</sub>	D <sub>6</sub>	D <sub>5</sub>	D <sub>4</sub>	D <sub>3</sub>	D <sub>2</sub>	D <sub>1</sub>	D <sub>0</sub>
Code	0	1	0	1	1	0	A <sub>4</sub>	A <sub>3</sub>	A <sub>2</sub>	A <sub>1</sub>	A <sub>0</sub>

A <sub>4</sub>	A <sub>3</sub>	A <sub>2</sub>	A <sub>1</sub>	A <sub>0</sub>	Line Address
0	0	0	0	0	0
				1	1
1	1	1	1	0	1E
1	1	1	1	1	1F

(c) Page Address Set

When MPU access the Display Data RAM, the page address corresponded to the row address must be selected.

The access in the Display Data RAM is available by setting the page and column address. (Refer the Fig. 1.)

The display is no change when the page address is changed.

	R/W										
	A0	$\overline{\text{RD}}$	$\overline{\text{WR}}$	D <sub>7</sub>	D <sub>6</sub>	D <sub>5</sub>	D <sub>4</sub>	D <sub>3</sub>	D <sub>2</sub>	D <sub>1</sub>	D <sub>0</sub>
Code	0	1	0	1	0	1	1	1	0	A <sub>1</sub>	A <sub>0</sub>

A <sub>1</sub>	A <sub>0</sub>	Page
0	0	0
0	1	1
1	0	2
1	1	3

**(d) Column Address Set**

This instruction set the column address in the Display Data RAM. (See Fig.1.)

When the MPU access the Display Data RAM continuously, the column address increase "1" automatically, therefore, the MPU can access the data only without address setting.

The increment of the column address is stopped by the address of 50<sub>H</sub> automatically, but the page address is no change even if the column address increase to 50<sub>H</sub> and stop.

	A0	$\overline{RD}$	R/W WR	D <sub>7</sub>	D <sub>6</sub>	D <sub>5</sub>	D <sub>4</sub>	D <sub>3</sub>	D <sub>2</sub>	D <sub>1</sub>	D <sub>0</sub>
Code	0	1	0	0	A <sub>6</sub>	A <sub>5</sub>	A <sub>4</sub>	A <sub>3</sub>	A <sub>2</sub>	A <sub>1</sub>	A <sub>0</sub>

A <sub>6</sub>	A <sub>5</sub>	A <sub>4</sub>	A <sub>3</sub>	A <sub>2</sub>	A <sub>1</sub>	A <sub>0</sub>	Column Add.
0	0	0	0	0	0	0	0
0	0	0	0	0	0	1	1
1	0	0	1	1	1	0	4E
1	0	0	1	1	1	1	4F

**(e) Status Read**

This instruction read out the internal status.

	A0	$\overline{RD}$	R/W WR	D <sub>7</sub>	D <sub>6</sub>	D <sub>5</sub>	D <sub>4</sub>	D <sub>3</sub>	D <sub>2</sub>	D <sub>1</sub>	D <sub>0</sub>
Code	0	0	1	BUSY	ADC	ON/OFF	RESET	0	0	0	0

**BUSY** : BUSY=1 indicate the operating or the Reset cycle.

The instruction can be input after the BUSY status change to "0".

**ADC** : Indicate the output correspondence of column(segment) address and segment driver.

0 : Counterclockwise Output (Inverse) Column Address 79-n ↔ Segment Driver n

1 : Clockwise Output (Normal) Column Address n ↔ Segment Driver n

**ON/OFF** : Indicate the whole display On/Off status.

0 : Whole Display "On"

1 : Whole Display "Off"

(Note) The data "0=On" and "1=Off" of Display On/Off status read out is inverted with the Display On/Off instruction data of "1=On" and "0=Off".

**RESET** : Indicate the initialization period by  $\overline{RST}$  signal or reset instruction.

0 : -

1 : Initialization Period

**(f) Write Display Data**

This instruction write the 8-bit data on the data bus into the Display Data RAM.

The column(segment) address increase "1" automatically when writing, therefore, the MPU can write the 8-bit data into the Display Data RAM without address setting.

	A0	$\overline{RD}$	R/W WR	D <sub>7</sub>	D <sub>6</sub>	D <sub>5</sub>	D <sub>4</sub>	D <sub>3</sub>	D <sub>2</sub>	D <sub>1</sub>	D <sub>0</sub>
Code	1	1	0	Write Data							

(g) Read Display Data

This instruction read out the 8-bit data from Display Data RAM which addressed by the column and page address. In case of the Read Modify Write Mode is Off, the column address increase "1" automatically after each read out, therefore, the MPU can read out the 8-bit data from the Display Data RAM continuously without address setting. One time of dummy read must be required after column address set as explain in (4-3).

	A0	$\overline{RD}$	R/W $\overline{WR}$	D <sub>7</sub>	D <sub>6</sub>	D <sub>5</sub>	D <sub>4</sub>	D <sub>3</sub>	D <sub>2</sub>	D <sub>1</sub>	D <sub>0</sub>
Code	1	0	1	Read Data							

(h) ADC Select

This instruction set the correspondence of column address in the Display Data RAM and segment driver output. (See Fig. 1.) Therefore, the order of segment output can be changed by the software, and no restriction of the LSI placement against the LCD panel.

	A0	$\overline{RD}$	R/W $\overline{WR}$	D <sub>7</sub>	D <sub>6</sub>	D <sub>5</sub>	D <sub>4</sub>	D <sub>3</sub>	D <sub>2</sub>	D <sub>1</sub>	D <sub>0</sub>
Code	0	1	0	1	0	1	0	0	0	0	D

D 0 : Clockwise Output (Inverse)  
 1 : CounterClockwise Output (Normal)

(i) Static Drive On/Off

This instruction executes the all common output turns on and whole display on obligatory.

	A0	$\overline{RD}$	R/W $\overline{WR}$	D <sub>7</sub>	D <sub>6</sub>	D <sub>5</sub>	D <sub>4</sub>	D <sub>3</sub>	D <sub>2</sub>	D <sub>1</sub>	D <sub>0</sub>
Code	0	1	0	1	0	1	0	0	1	0	D

D 0 : Static Drive Off (Normal Operation)  
 1 : Static Drive On (Whole Display Turns On)

When the Display Off mode is selected (Display Off) in Static Drive On status, the internal circuits put on the power save mode.

(j) Duty Select

Basically, the duty ratio for the NJU6453A is determined by the FR signal but when the NJU6453A combined with NJU6452, the duty ratio must be set as same as NJU6452A.

	A0	$\overline{RD}$	R/W $\overline{WR}$	D <sub>7</sub>	D <sub>6</sub>	D <sub>5</sub>	D <sub>4</sub>	D <sub>3</sub>	D <sub>2</sub>	D <sub>1</sub>	D <sub>0</sub>
Code	0	1	0	1	0	1	0	1	0	0	D

D 0 : 1/16 duty  
 1 : 1/32 duty

5

(k) Read Modify Write

After this instruction is executed, the column address increase "1" automatically when Display Data Write Instruction execution, but the address is not changed when the Display Data Read Instruction execution.

This status continues during End instruction execution. When the End instruction is entered the column address back to the address where Read Modify Write instruction entering.

By this function, the load of MPU for example cyclic data writing operation like as cursor blink etc., can be reduced.

	A0	RD	R/W WR	D <sub>7</sub>	D <sub>6</sub>	D <sub>5</sub>	D <sub>4</sub>	D <sub>3</sub>	D <sub>2</sub>	D <sub>1</sub>	D <sub>0</sub>
Code	0	1	0	1	1	1	0	0	0	0	0

Note) During the Read Modify Write mode, any instruction except Column Address Set can be executed.

(l) Sequence of cursor display

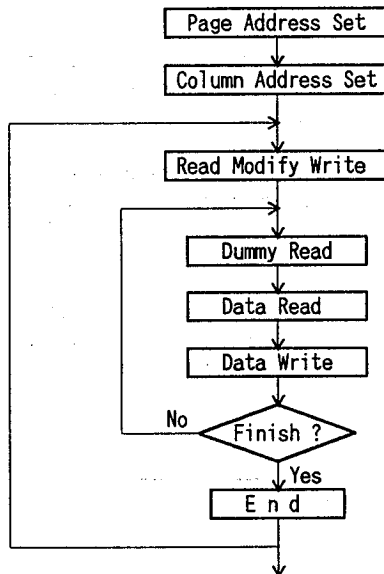

(m) End

This instruction release the Read Modify Write mode and the column address back to the address where the read modify write mode setting.

	A0	RD	R/W WR	D <sub>7</sub>	D <sub>6</sub>	D <sub>5</sub>	D <sub>4</sub>	D <sub>3</sub>	D <sub>2</sub>	D <sub>1</sub>	D <sub>0</sub>
Code	0	1	0	1	1	1	0	1	1	1	0

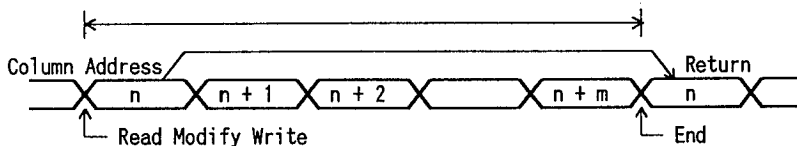

(n) Reset

This instruction executes the following initialization.

Initialization

- ① Set the 1st line in the Display Start Line Register.
- ② Set the page 3 in the Page Register.

In this time, there are no influence to the Display Data RAM.

	AO	RD	R/W WR	D <sub>7</sub>	D <sub>6</sub>	D <sub>5</sub>	D <sub>4</sub>	D <sub>3</sub>	D <sub>2</sub>	D <sub>1</sub>	D <sub>0</sub>
Code	0	1	0	1	1	1	0	0	0	1	0

The reset signal input to the  $\overline{RST}$  terminal must be required for the initialization when the power turns on.

(Note) The initialization when the power turns on can not be executed by Reset instruction.

(o) Power Save(Dual Command)

When both of Display Off and Static Drive On are executed, the internal circuits put on the power save mode and the current consumption is reduced as same as stand by current. The internal status in this mode are as follows;

- ① Stop the LCD driving. Segment and Common drivers output  $V_{DD}$  level.
- ② Stop the oscillation or inhibit the external clock input. Then the terminal OSC<sub>2</sub> becomes floating status.
- ③ Keeping the display data and operating mode.

The power save mode is released by Display on or static drive off instruction. To reduce the total power consumption, the current flow on the bleeder resistance must be cut by the transistor etc. during the power save mode as shown below.

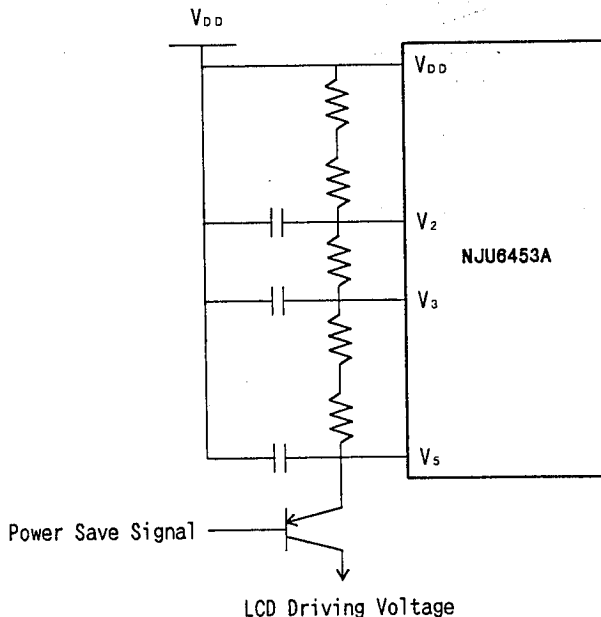

5

#### (4) MPU Interface

##### (4-1) 68 or 80 type MPU interface selection.

The NJU6453A can interface both of 68 or 80 type MPU bus directly by setting the  $\overline{RST}$  level after reset instruction entered as shown Table. 2.

The data transfer is executed between  $D_0 \sim D_7$  of NJU6453A and the MPU data bus.

During the CS signal is "H", the NJU6453A released from the the MPU and becomes stand-by mode. But the reset instruction can be input though the internal status of NJU6453A.

Table. 2.

Level of $\overline{RST}$	Type of MPU	A0	E	R/W	$D_0 \sim D_7$
"H"	68 type	↑	↑	↑	↑
"L"	80 type	↑	$\overline{RD}$	$\overline{WR}$	↑

##### (4-2) Discrimination of the data bus signal.

The NJU6453A discriminates the data bus signal by combination of A0, E( $\overline{RD}$ ), and R/W( $\overline{WR}$ ) signals as shown Table. 3.

Table. 3.

Common	68 type	80 type		Function
	R/W	$\overline{RD}$	$\overline{WR}$	
1	1	0	1	Display Data Read out
1	0	1	0	Display Data Write
0	1	0	1	Status Read
0	0	1	0	Command Input to the Register

##### (4-3) Access to the Display Data RAM and Internal Register.

The NJU6453A is operating as one of Pipe-line processor by the bus-holder connecting to the internal data bus to adjust the operation frequency between MPU and the Display Data RAM or Internal Register.

For example, when the MPU write the data into the Display Data RAM, the data is held in the bus-holder at once then write into the Display Data RAM by next data write cycle.

Therefore high speed data transmission between MPU and NJU6453A is available because of the limitation of access time of NJU6453A locking from MPU is just determined by the cycle time only which ignored the access time of  $t_{ACC}$  and  $t_{DS}$  of Display Data RAM.

If the cycle time can not be kept in the MPU operation, NOP operation cycle must be insert which equivalent to the waiting operation.

Please note that the read out data is a address data when the read out execution just after the address setting. Therefore, one dummy read is required after address setting or write cycle as shown in Fig. 2.

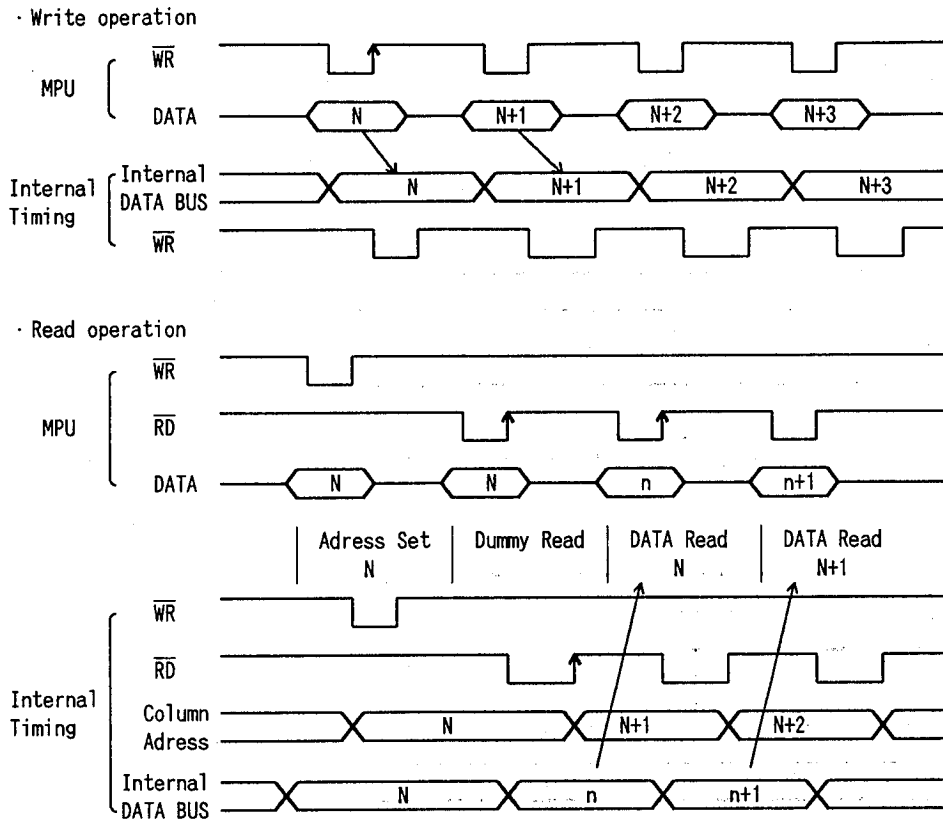

Fig.2 MPU Interface Timing

5

### ■ ABSOLUTE MAXIMUM RATINGS

(Ta=25°C)

PARAMETER	SYMBOL	RATINGS	UNIT
Supply Voltage (1)	V <sub>DD</sub>	- 0.3 ~ + 7.0	V
Supply Voltage (2)	V <sub>1</sub> ~ V <sub>5</sub> (3)	V <sub>DD</sub> -13.5 ~ V <sub>DD</sub> +0.3	V
Input Voltage	V <sub>IN</sub>	- 0.3 ~ V <sub>DD</sub> +0.3	V
Operating Temperature	T <sub>opr</sub>	- 30 ~ + 80	°C
Storage Temperature	T <sub>stg</sub>	- 55 ~ + 125	°C

Note 1) If the LSI are used on condition above the absolute maximum ratings, the LSI may be destroyed. Using the LSI within electrical characteristics is strongly recommended for normal operation. Use beyond the electric characteristics conditions will cause malfunction and poor reliability.

Note 2) All voltage values are specified as V<sub>SS</sub> = 0 V.

Note 3) The relation : V<sub>DD</sub> ≥ V<sub>2</sub> ≥ V<sub>3</sub> ≥ V<sub>5</sub> must be maintained.

### ■ ELECTRICAL CHARACTERISTICS

(V<sub>DD</sub>=5V±10%, V<sub>SS</sub>=0V, Ta=-20~+75°C)

PARAMETER		SYMBOL	CONDITIONS	MIN	TYP	MAX	UNIT	Note	
Operating Voltage(1)	Recommend	V <sub>DD</sub>		4.5	5.0	5.5	V	4	
	Available			2.4		6.0			
Operating Voltage(2)	Recommend	V <sub>5</sub>		V <sub>DD</sub> -13.5		V <sub>DD</sub> -3.5	V		
	Available			V <sub>DD</sub> -13.5					
	Available	V <sub>2</sub>	V <sub>LCD</sub> =V <sub>DD</sub> -V <sub>5</sub>	V <sub>DD</sub> -0.6xV <sub>LCD</sub>		V <sub>DD</sub>			
	Available	V <sub>3</sub>		V <sub>5</sub>		V <sub>DD</sub> -0.4xV <sub>LCD</sub>			
Input Voltage	1	V <sub>IHT</sub>	CS, AO, D <sub>0</sub> ~D <sub>7</sub> , E, R/W Terminals	2.0		V <sub>DD</sub>	V		
		V <sub>ILT</sub>		V <sub>SS</sub>		0.8			
	2	V <sub>IHC</sub>	CL, FR, RST Terminals	0.8xV <sub>DD</sub>		V <sub>DD</sub>			
		V <sub>ILC</sub>		V <sub>SS</sub>		0.2xV <sub>DD</sub>			
Output Voltage		V <sub>OHT</sub>	D <sub>0</sub> ~D <sub>7</sub> Terminals	2.4			V		
		V <sub>OLT</sub>		I <sub>OH</sub> =-3.0mA					0.4
	1	V <sub>OHC1</sub>	FR Terminal	I <sub>OH</sub> =-2.0mA	2.4				
		V <sub>OLC1</sub>		I <sub>OL</sub> = 3.0mA					0.4
Input Leakage Current		I <sub>LI</sub>	AO, E, R/W, CS, CL, RST	-1.0		1.0	uA	5	
		I <sub>LO</sub>	D <sub>0</sub> ~D <sub>7</sub> , FR Terminals	-3.0		3.0	uA		
Driver On-resistance		R <sub>ON</sub>	Ta=25°C		5.0	7.5	kΩ	6	
			V <sub>5</sub> =V <sub>DD</sub> -5.0V						
			V <sub>5</sub> =V <sub>DD</sub> -3.5V						
Stand-by Current		I <sub>DDQ</sub>	CS=CL=V <sub>DD</sub>		0.05	1.0	uA		
Operating Current		I <sub>DD1</sub>	Display V <sub>5</sub> =V <sub>DD</sub> -5.0V, f <sub>CL</sub> =2kHz		2.0	5.0	uA	7	
		I <sub>DD2</sub>	Accessing, tcyc=200kHz		300	500	uA		
Reset time		t <sub>r</sub>	RST Terminal	1.0		1000	us		

Note 4) NJU6453A can operate wide operating range, but it is not guarantee immediate voltage changing during the accessing of the MPU.

Note 5) Apply to the High-impedance state of D0 to D7 and FR terminals.

Note 6) R<sub>ON</sub> is the resistance values between power supply terminals(V<sub>2</sub>,V<sub>3</sub>) and each output terminals of common and segment supplied by 0.1V.

Note 7) The  $I_{DD2}$  is specified under the condition of cyclic( $t_{cyc}$ )inverted data input continuously. The operating current during the accessing is proportionate to the frequency of  $t_{cyc}$ . In the no accessing it is as same as  $I_{DD1}$ .

## ■ BUS TIMING CHARACTERISTICS

· Read / Write operation sequence (68 Type MPU)

( $V_{DD}=5.0V \pm 10\%$ ,  $V_{SS}=0V$ ,  $T_a=-20 \sim +75^\circ C$ )

PARAMETER		SYMBOL	MIN	MAX	CONDITION	UNIT
Address Set Up Time	AO,R/W, $\overline{CS}$	$t_{AWS}$	20			ns
		Address Hold Time	$t_{AHS}$	10		
System Cycle Time	$t_{CYS}$		1000			
	Enable		E Terminal	$t_{EW}$		
Pulse Width		80				
Data Set Up Time	$D_0 \sim D_7$	$t_{DSE}$	80			
Data Hold Time		$t_{DHS}$	10			
Access Time	Terminals	$t_{ACS}$		90	$C_L=100pF$	
Output Disable Time		$t_{CHS}$	10	60		

Note 8) Input signal rise time( $t_r$ ) and fall time( $t_f$ ) are less than 15ns.

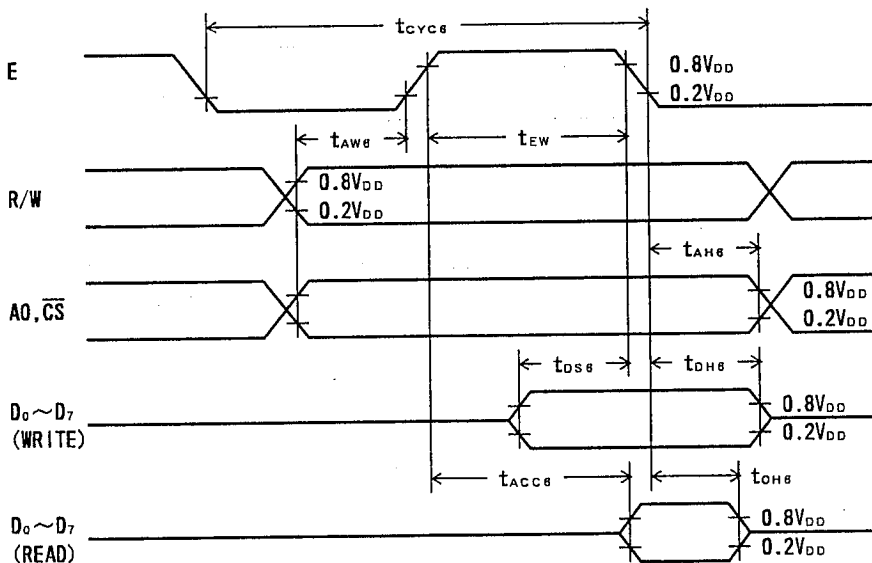

fig.3 Bus Read / Write operation sequence (68 Type MPU)

## • Read / Write operation sequence (80 Type MPU)

 ( $V_{DD}=5.0V \pm 10\%$ ,  $V_{SS}=0V$ ,  $T_a=-20 \sim +75^\circ C$ )

PARAMETER	SYMBOL	MIN	MAX	CONDITION	UNIT
Address Set Up Time	$A0, \overline{CS}$	$t_{AW8}$	20		ns
Address Hold Time	Terminal	$t_{AH8}$	10		
System Cycle Time	$\overline{RW}, \overline{WR}$	$t_{CYC8}$	1000		
Control Pulse Width	Terminals	$t_{CC}$	200		
Data Set Up Time	$D_0 \sim D_7$	$t_{DS8}$	80		
Data Hold Time		$t_{DH8}$	10		
RD Access Time	Terminals	$t_{ACC8}$	90	$C_L=100pF$	
Output Disable Time		$t_{CH8}$	10		60

 Note 9) Input signal rise time( $t_r$ ) and fall time( $t_f$ ) are less than 15ns.

fig.4 Bus Read / Write operation sequence (80 Type MPU)

· Display control timing characteristics (Both of 68 and 80 type MPU)

Input Timing ( $V_{DD}=5.0V \pm 10\%$ ,  $V_{SS}=0V$ ,  $T_a=-20 \sim +75^\circ C$ )

PARAMETER	SYMBOL	MIN	TYP	MAX	CONDITION	UNIT
"L" level Pulse Width	$t_{WLCL}$	35				us
"H" level Pulse Width	$t_{WHCL}$	35				
Rise Time	$t_r$		30	150		ns
Fall Time	$t_f$		30	150		
FR Delay Time (NJU6453A Slave)	$t_{DFR}$	-2.0		2.0		us

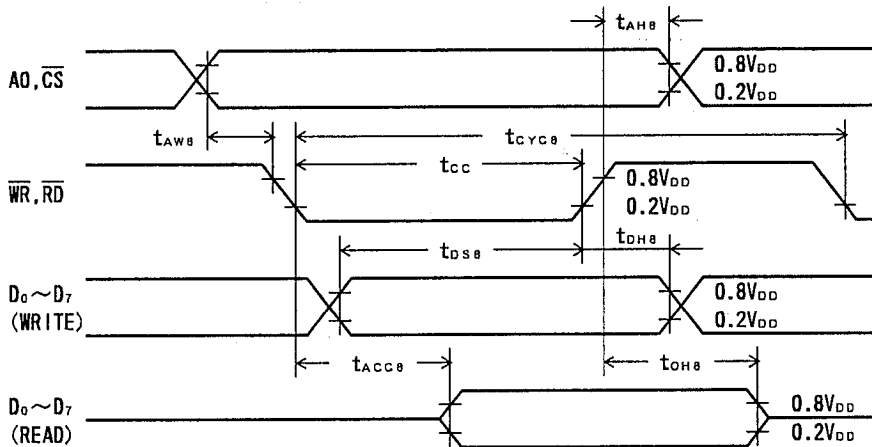
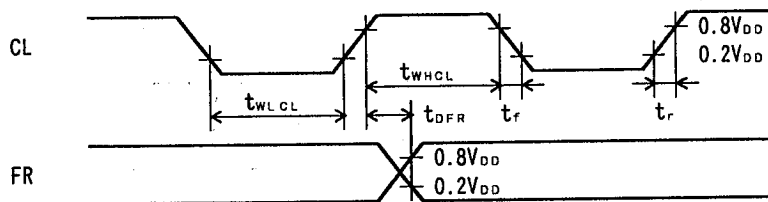
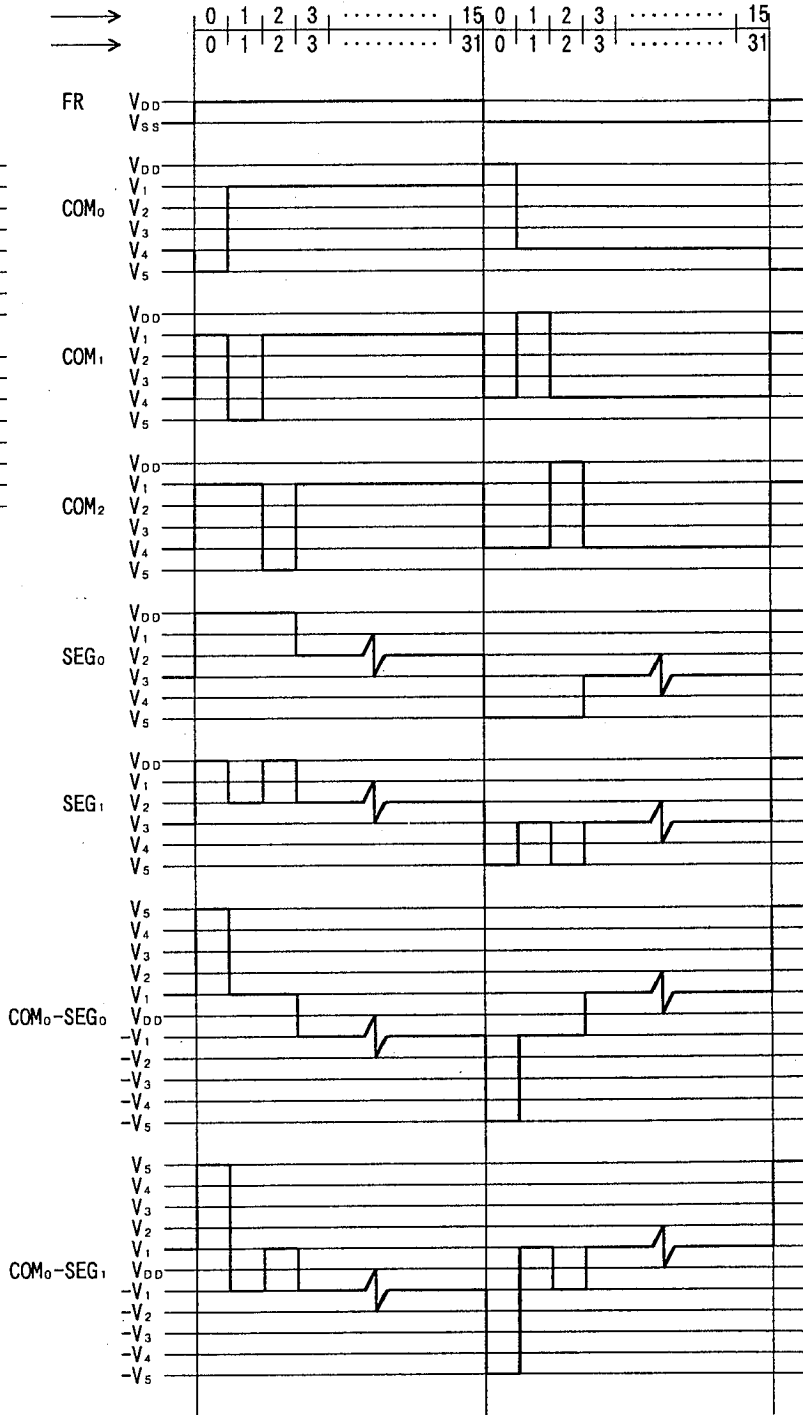
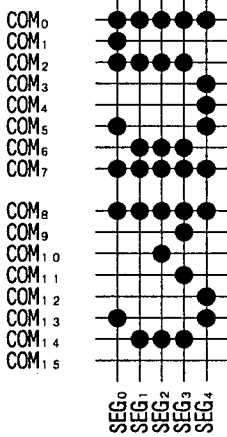

fig.5 Display control timing characteristics

5

## ■ LCD DRIVING WAVEFORM

1/5 BIAS, 1/16 DUTY  
1/6 BIAS, 1/32 DUTY



## APPLICATION CIRCUITS 1

· 68 type MPU Interface

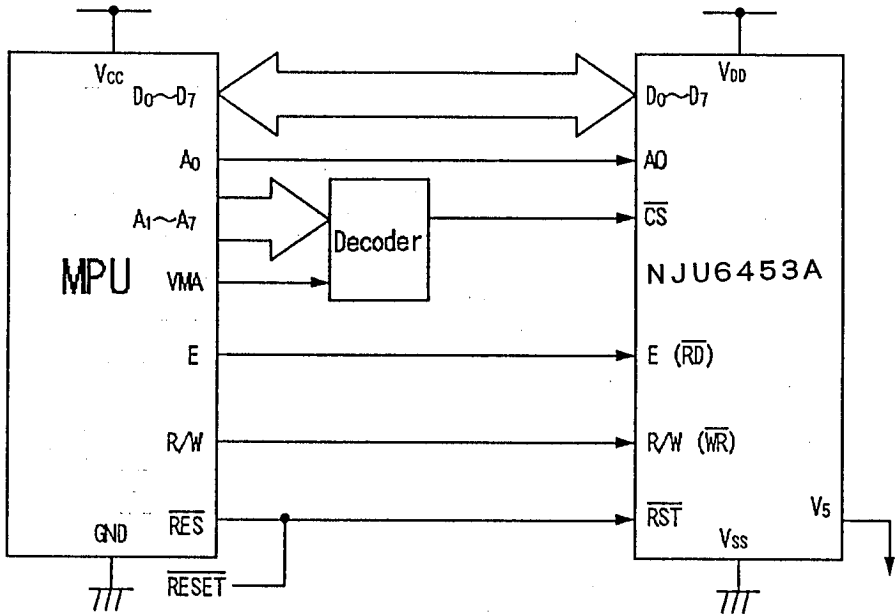

· 80 type MPU Interface

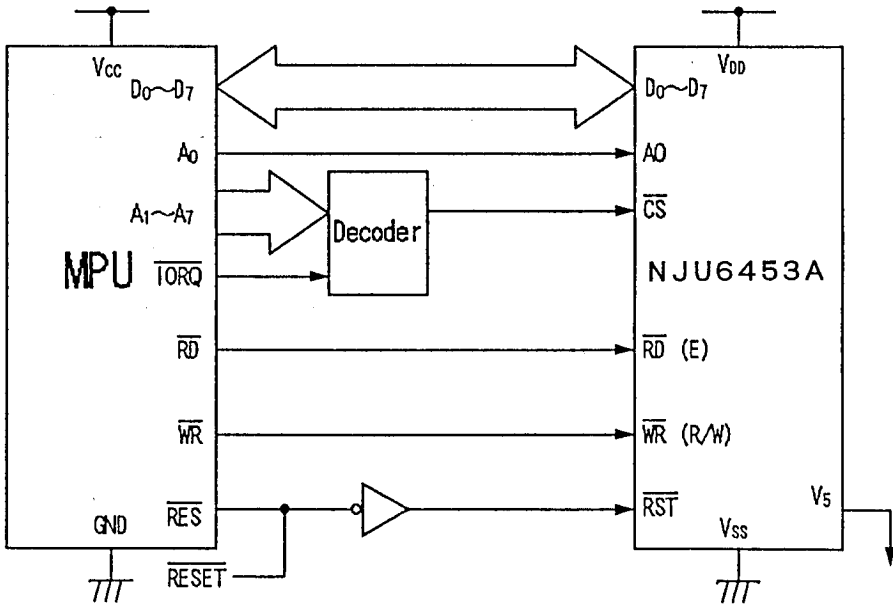

5

## APPLICATION CIRCUITS 2

- Combination of NJU6452A and NJU6453A  
(16 x 141 dots Driving Application Circuits)

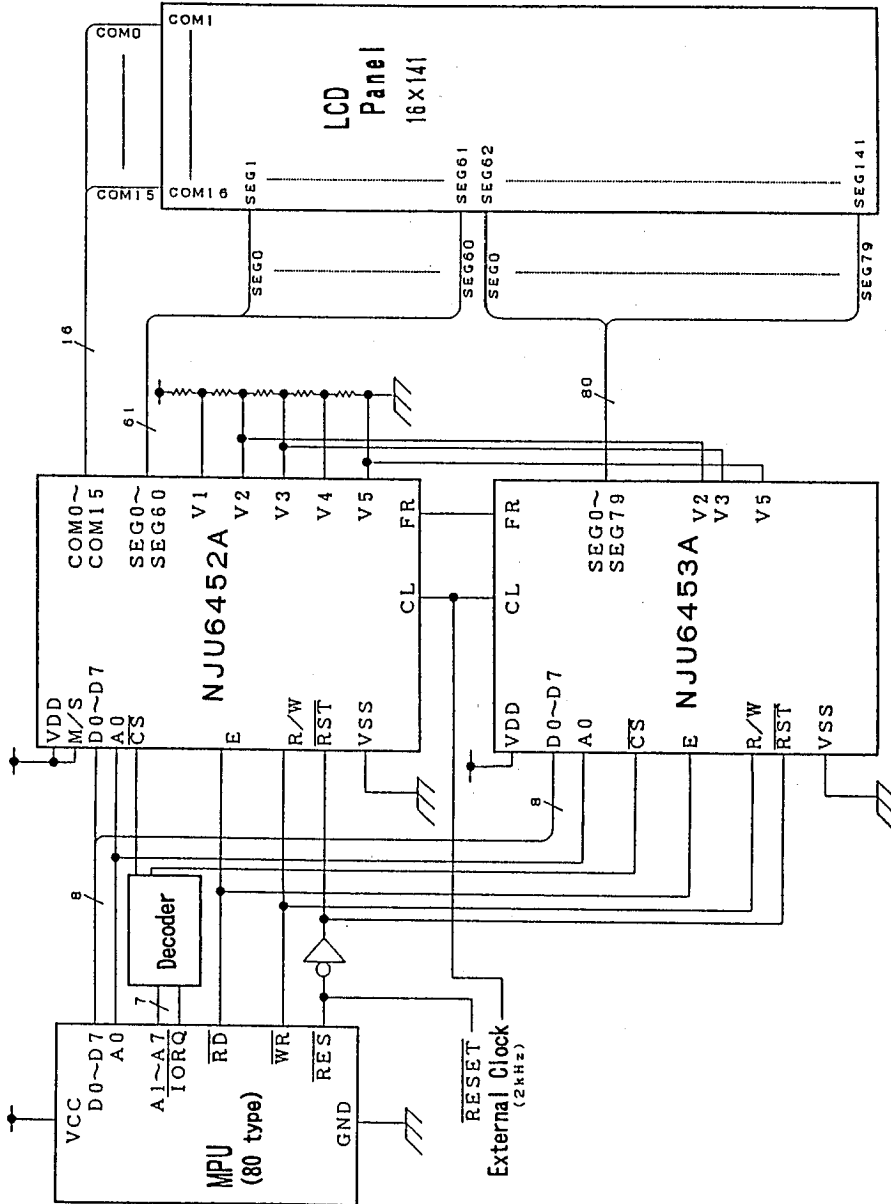

## MEMO

**[CAUTION]**

The specifications on this databook are only given for information, without any guarantee as regards either mistakes or omissions. The application circuits in this databook are described only to show representative usages of the product and not intended for the guarantee or permission of any right including the industrial rights.