

# VHPX8-6W-4GR



2.4 m | 8 ft ValuLine® High Performance Parabolic Shielded Antenna, dual-polarized, 5.925–7.125 GHz, PDR70, gray antenna, white fabric radome without flash, standard pack—two-piece reflector

## **OBSOLETE**

**This product was discontinued on: February 1, 2019**

**This part number is supported until: July 15, 2013**

### **Replaced By:**

HX8-6W-4GF

2.4m | 8ft ValuLine® High Performance, High XPD Antenna, dual-polarized, 5.925 – 7.125 GHz, grey, PDR70 flange

## Product Classification

<b>Brand</b>	ValuLine®
<b>Product Type</b>	Microwave antenna

## General Specifications

<b>Antenna Type</b>	VHPX - ValuLine® High Performance Shielded Antenna, dual-polarized
<b>Diameter, nominal</b>	2.4 m   8 ft
<b>Packing</b>	Standard pack
<b>Radome Color</b>	White
<b>Radome Material</b>	Fabric
<b>Reflector Construction</b>	Two-piece reflector
<b>Antenna Input</b>	PDR70
<b>Antenna Color</b>	Gray
<b>Antenna Type</b>	VHPX - ValuLine® High Performance Shielded Antenna, dual-polarized
<b>Diameter, nominal</b>	2.4 m   8 ft
<b>Flash Included</b>	No
<b>Polarization</b>	Dual

## Electrical Specifications

<b>Operating Frequency Band</b>	5.925 – 7.125 GHz
<b>Beamwidth, Horizontal</b>	1.4 °
<b>Beamwidth, Vertical</b>	1.4 °

# VHPX8-6W-4GR

---

<b>Cross Polarization Discrimination (XPD)</b>	35 dB
<b>Cross Polarization Discrimination Note</b>	35 dB boresight only (i.e., angle coincident with co-polar max), compliant to ETSI XPD class 2 (30 dB) at 1 dB co-polar contour
<b>Electrical Compliance</b>	ETSI Class 3   US FCC Part 101A
<b>Front-to-Back Ratio</b>	69 dB
<b>Gain, Low Band</b>	41.2 dBi
<b>Gain, Mid Band</b>	42.1 dBi
<b>Gain, Top Band</b>	42.9 dBi
<b>Input Power, maximum</b>	43 dBm
<b>Operating Frequency Band</b>	5.925 – 7.125 GHz
<b>Radiation Pattern Envelope Reference (RPE)</b>	7307
<b>Return Loss</b>	23.1 dB
<b>VSWR</b>	1.15

## Mechanical Specifications

<b>Fine Azimuth Adjustment</b>	±5°
<b>Fine Elevation Adjustment</b>	±5°
<b>Mounting Pipe Diameter</b>	115 mm   4.5 in
<b>Net Weight</b>	227 kg   500 lb
<b>Side Struts, Included</b>	1 inboard   1 outboard
<b>Side Struts, Optional</b>	2 outboard
<b>Wind Velocity Operational</b>	110 km/h   68 mph
<b>Wind Velocity Survival Rating</b>	200 km/h   125 mph

## Wind Forces At Wind Velocity Survival Rating

<b>Angle <math>\alpha</math> for MT Max</b>	-110 °
<b>Axial Force (FA)</b>	11284 N   2537 lbf
<b>Force on Inboard Strut Side</b>	4260 N   958 lbf
<b>Force on Outboard Strut Side</b>	5630 N   1266 lbf
<b>Side Force (FS)</b>	5590 N   1257 lbf
<b>Twisting Moment (MT)</b>	4901 N-m   3615 ft lb
<b>Weight with 1/2 in (12 mm) Radial Ice</b>	454 kg   1001 lb
<b>Zcg with 1/2 in (12 mm) Radial Ice</b>	729 mm   29 in
<b>Zcg without Ice</b>	673 mm   26 in

## Wind Forces At Wind Velocity Survival Rating Image

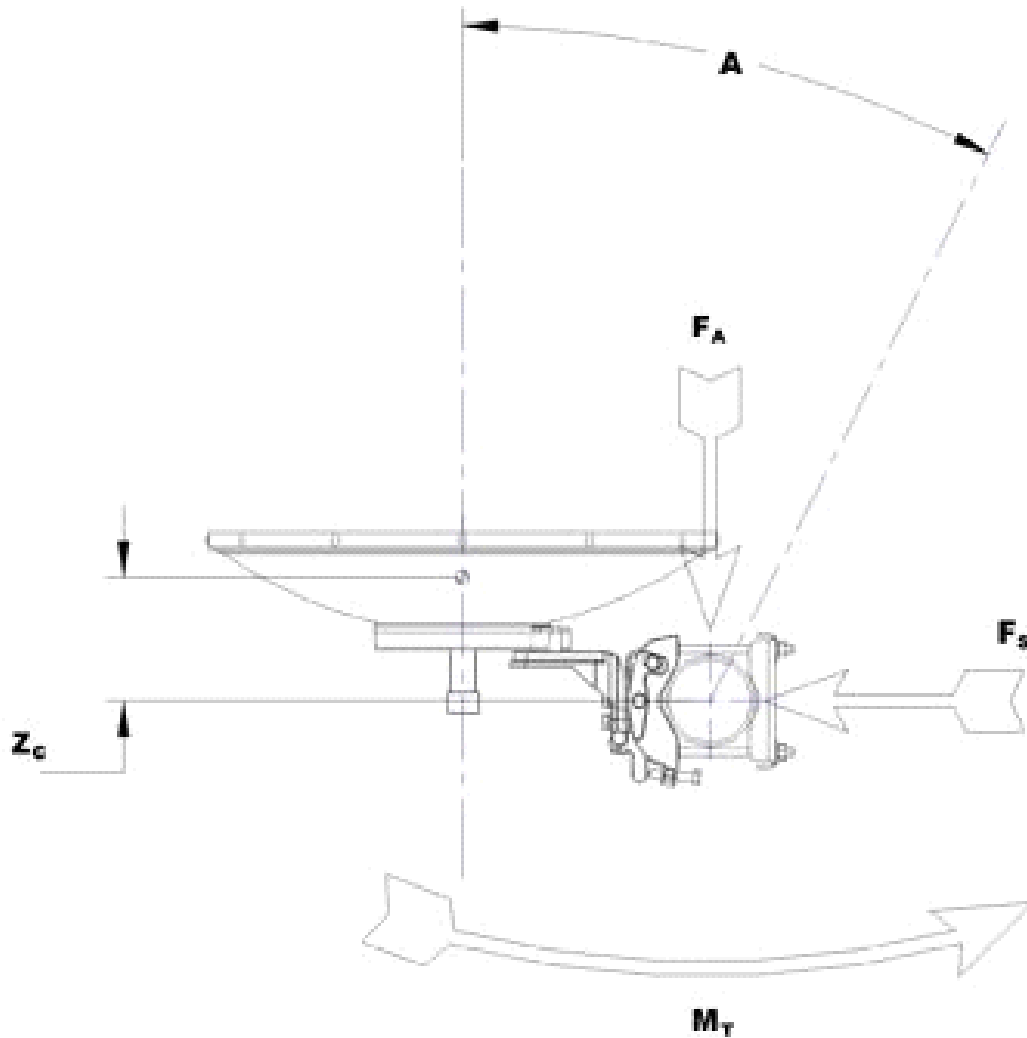

### Packed Dimensions

<b>Gross Weight, Packed Antenna</b>	421.0 kg   928.1 lb
<b>Height</b>	1590.0 mm   62.6 in
<b>Length</b>	2740.0 mm   107.9 in
<b>Volume</b>	5.1 m <sup>3</sup>
<b>Width</b>	1160.0 mm   45.7 in

## Antenna Dimensions And Mounting Information

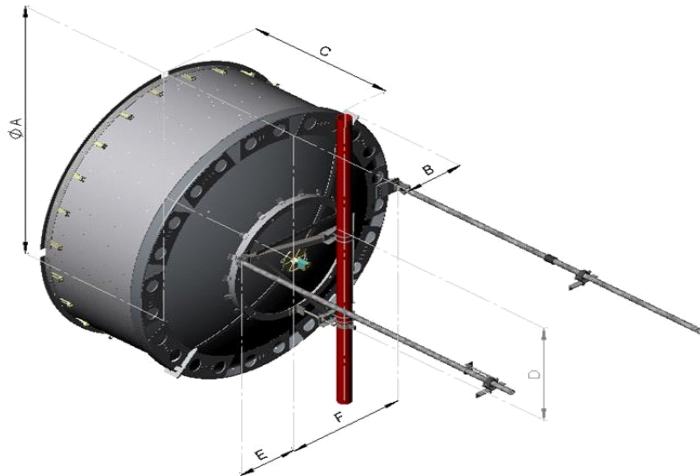

Dimensions in Inches (mm)						
Antenna Size, ft (m)	A	B	C	D	E	F
8 (2.4)	100.3 (2549)	8 (203)	66.15 (1680)	39.2 (995)	30.5 (775)	43.63 (1108)

## Regulatory Compliance/Certifications

Agency	Classification
ISO 9001:2015	Designed, manufactured and/or distributed under this quality management system



### \* Footnotes

<b>Axial Force (FA)</b>	Maximum forces exerted on a supporting structure as a result of wind from the most critical direction for this parameter. The individual maximums specified may not occur simultaneously. All forces are referenced to the mounting pipe.
<b>Cross Polarization Discrimination (XPD)</b>	The difference between the peak of the co-polarized main beam and the maximum cross-polarized signal over an angle twice the 3 dB beamwidth of the co-polarized main beam.
<b>Front-to-Back Ratio</b>	Denotes highest radiation relative to the main beam, at $180^\circ \pm 40^\circ$ , across the band. Production antennas do not exceed rated values by more than 2 dB unless stated otherwise.
<b>Gain, Mid Band</b>	For a given frequency band, gain is primarily a function of antenna size. The gain of Andrew antennas is determined by either gain by comparison or by computer integration of the measured antenna patterns.
<b>Operating Frequency Band</b>	Bands correspond with CCIR recommendations or common allocations used throughout the world. Other ranges can be accommodated on special order.

<b>Packing</b>	Andrew standard packing is suitable for export. Antennas are shipped as standard in totally recyclable cardboard or wire-bound crates (dependent on product). For your convenience, Andrew offers heavy duty export packing options.
<b>Radiation Pattern Envelope Reference (RPE)</b>	Radiation patterns define an antenna's ability to discriminate against unwanted signals. Under still dry conditions, production antennas will not have any peak exceeding the current RPE by more than 3dB, maintaining an angular accuracy of +/-1° throughout
<b>Return Loss</b>	The figure that indicates the proportion of radio waves incident upon the antenna that are rejected as a ratio of those that are accepted.
<b>Side Force (FS)</b>	Maximum side force exerted on the mounting pipe as a result of wind from the most critical direction for this parameter. The individual maximums specified may not occur simultaneously. All forces are referenced to the mounting pipe.
<b>Twisting Moment (MT)</b>	Maximum forces exerted on a supporting structure as a result of wind from the most critical direction for this parameter. The individual maximums specified may not occur simultaneously. All forces are referenced to the mounting pipe.
<b>VSWR</b>	Maximum; is the guaranteed Peak Voltage-Standing-Wave-Ratio within the operating band.
<b>Wind Velocity Operational</b>	The wind speed where the antenna deflection is equal to or less than 0.1 degrees. In the case of ValuLine antennas, it is defined as a maximum deflection of 0.3 x the 3 dB beam width of the antenna.
<b>Wind Velocity Survival Rating</b>	The maximum wind speed the antenna, including mounts and radomes, where applicable, will withstand without permanent deformation. Realignment may be required. This wind speed is applicable to antenna with the specified amount of radial ice.