

16-Bit Bidirectional Transceiver with 3-State Outputs

GENERAL DESCRIPTION

The ML65F16245 is a BiCMOS, non-inverting 16-bit transceiver with 3-state outputs. This device was specifically designed for high speed bus applications. Its 16 channels support propagation delay of 2ns maximum, and fast output enable and disable times of 5ns or less to minimize datapath delay.

This device is designed to minimize undershoot, overshoot, and ground bounce to decrease noise delays. These transceivers implement a unique digital and analog implementation to eliminate the delays and noise inherent in traditional digital designs. The device offers a new method for quickly charging up a bus load capacitor to minimize bus settling times, or FastBus™ Charge. FastBus Charge is a transition current, (specified as $I_{DYNAMIC}$) that injects between 60 to 200mA (depending on output load) of current during the rise time and fall time. This current is used to reduce the amount of time it takes to charge up a heavily-capacitive loaded bus, effectively reducing the bus settling times, and improving data/clock margins in tight timing budgets.

Micro Linear's solution is intended for applications for critical bus timing designs that include minimizing device propagation delay, bus settling time, and time delays due to noise. Applications include; high speed memory arrays, bus or backplane isolation, bus to bus bridging, and sub-2ns propagation delay schemes.

The ML65F16245 follows the pinout and functionality of the industry standard 2.7V to 3.6V-logic families.

FEATURES

- Low propagation delays — 2ns maximum for 3.3V, 2.5ns maximum for 2.7V
- Fast output enable/disable times of 5ns maximum
- FastBus Charge current to minimize the bus settling time during active capacitive loading
- 2.7V to 3.6V a V_{CC} supply operation; LV-TTL compatible input and output levels with 3-state capability
- Industry standard pinout compatible to FCT, ALV, LCX, LVT, and other low voltage logic families
- ESD protection exceeds 2000V
- Full output swing for increased noise margin
- Undershoot and overshoot protection to 400mV typically
- Low ground bounce design

BLOCK DIAGRAM

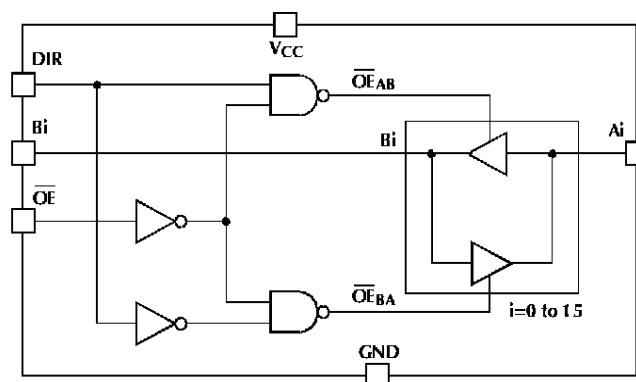

ML65F16245

PIN CONFIGURATION

ML65F16245
48-Pin SSOP (R48)
48-Pin TSSOP (T48)

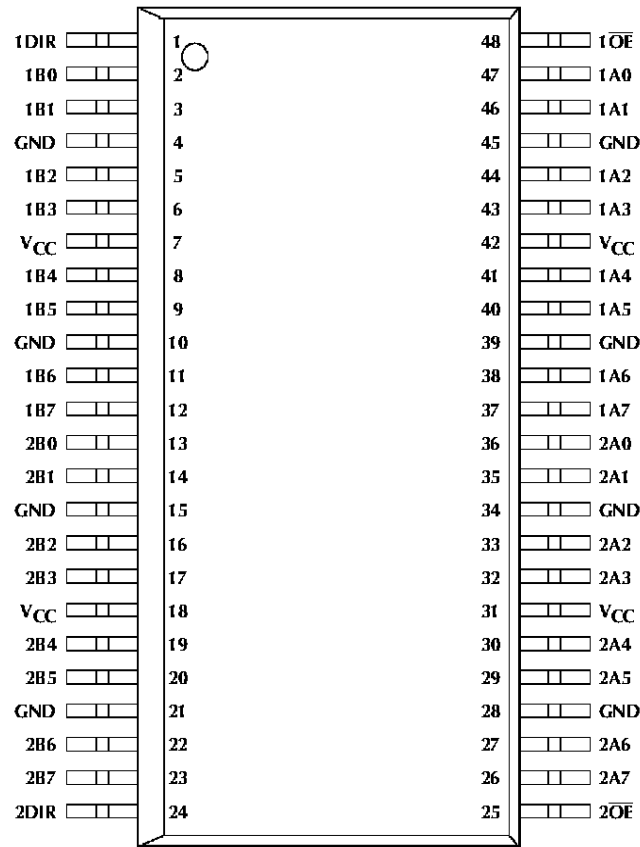

TOP VIEW

FUNCTION TABLE

(Each 8-bit section)

\overline{OE}	DIR	A _i	B _i	FUNCTION
H	X	Z	Z	Disable
L	L	Output	Input	Bus B to Bus A
L	H	Input	Output	Bus A to Bus B

L = Logic Low, H = Logic High, X = Don't Care, Z = High Impedance

i = 0 to 7

PIN DESCRIPTION

PIN	NAME	FUNCTION	PIN	NAME	FUNCTION
1	1DIR	Direction Select	25	$\overline{2OE}$	Output Enable
2	1B0	Data Bus 1B	26	2A7	Data Bus 2A
3	1B1	Data Bus 1B	27	2A6	Data Bus 2A
4	GND	Signal Ground	28	GND	Signal Ground
5	1B2	Data Bus 1B	29	2A5	Data Bus 2A
6	1B3	Data Bus 1B	30	2A4	Data Bus 2A
7	V _{CC}	2.7V to 3.6V Supply	31	V _{CC}	2.7V to 3.6V Supply
8	1B4	Data Bus 1B	32	2A3	Data Bus 2A
9	1B5	Data Bus 1B	33	2A2	Data Bus 2A
10	GND	Signal Ground	34	GND	Signal Ground
11	1B6	Data Bus 1B	35	2A1	Data Bus 2A
12	1B7	Data Bus 1B	36	2A0	Data Bus 2A
13	2B0	Data Bus 2B	37	1A7	Data Bus 1A
14	2B1	Data Bus 2B	38	1A6	Data Bus 1A
15	GND	Signal Ground	39	GND	Signal Ground
16	2B2	Data Bus 2B	40	1A5	Data Bus 1A
17	2B3	Data Bus 2B	41	1A4	Data Bus 1A
18	V _{CC}	2.7V to 3.6V Supply	42	V _{CC}	2.7V to 3.6V Supply
19	2B4	Data Bus 2B	43	1A3	Data Bus 1A
20	2B5	Data Bus 2B	44	1A2	Data Bus 1A
21	GND	Signal Ground	45	GND	Signal Ground
22	2B6	Data Bus 2B	46	1A1	Data Bus 1A
23	2B7	Data Bus 2B	47	1A0	Data Bus 1A
24	2DIR	Direction Select	48	$\overline{1OE}$	Output Enable

ML65F16245

ABSOLUTE MAXIMUM RATINGS

Absolute maximum ratings are those values beyond which the device could be permanently damaged. Absolute maximum ratings are stress ratings only and functional device operation is not implied.

V_{CC}	7V
DC Input Voltage	-0.3V to $V_{CC} + 0.3V$
AC Input Voltage (PW < 20ns)	-3.0V
DC Output Voltage	-0.3V to 7VDC
Output Current, Source or Sink	180mA

Storage Temperature Range	-65°C to 150°C
Junction Temperature	150°C
Lead Temperature (Soldering, 10sec)	150°C
Thermal Impedance (θ_{JA})	76°C/W

OPERATING CONDITIONS

Temperature Range	0°C to 70°C
V_{IN} Operating Range	2.7V to 3.6V

ELECTRICAL CHARACTERISTICS

Unless otherwise specified, $V_{IN} = 3.3V$, $T_A =$ Operating Temperature Range (Note 1).

SYMBOL	PARAMETER	CONDITIONS	MIN	TYP	MAX	UNITS	
AC ELECTRICAL CHARACTERISTICS ($C_{LOAD} = 50pF$)							
t_{PHL}, t_{PLH}	Propagation Delay	Ai to/from Bi	3.3V	1.35	1.7	2	ns
			2.7V	1.25	1.9	2.5	ns
t_{OE}	Output Enable Time	OE to Ai/Bi	3.3V			5	ns
			2.7V			6	ns
		DIR to Ai/Bi	3.3V			5	ns
			2.7V			6	ns
t_{OD}	Output Disable Time	OE to Ai/Bi	3.3V			5	ns
			2.7V			6	ns
		DIR to Ai/Bi	3.3V			5	ns
			2.7V			6	ns
T_{OS}	Output-to-Output Skew				300	ps	
C_{IN}	Input Capacitance			8		pF	

DC ELECTRICAL CHARACTERISTICS ($C_{LOAD} = 50pF$, $R_{LOAD} =$ Open)

V_{IH}	Input High Voltage	Logic high	2.0			V
V_{IL}	Input Low Voltage	Logic low			0.8	V
I_{IH}	Input High Current	Per pin, $V_{IN} = 3V$			300	μA
I_{IL}	Input Low Current	Per pin, $V_{IN} = 0V$			300	μA
I_{HI-Z}	Three-State Output Current	$V_{CC} = 3.6V, 0 < V_{IN} < V_{CC}$			5	μA
V_{IC}	Input Clamp Voltage	$V_{CC} = 3.6V, I_{IN} = 18mA$		-0.7	-0.2	V
$I_{DYNAMIC}$	Dynamic Transition Current (FastBus Charge)	Low to high transitions		80		mA
		High to low transitions		80		mA
V_{OH}	Output High Voltage	$V_{CC} = 3.6V$	2.4	3.4		V
		$V_{CC} = 2.7V$	2.25	2.35		V
V_{OL}	Output Low Voltage	$V_{CC} = 3.6V$ and $2.7V$			0.6	V
I_{CC}	Quiescent Power Supply Current	$V_{CC} = 3.6V, f = 0Hz,$ inputs = V_{CC} or $0V$			3	μA

Note 1: Limits are guaranteed by 100% testing, sampling, or correlation with worst-case test conditions.

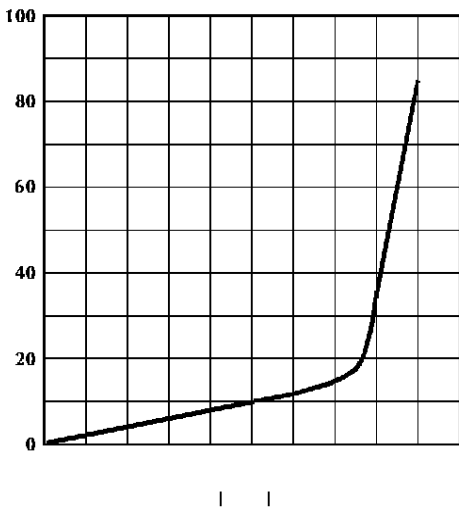

Figure 1a. Typical V_{OL} vs. I_{OL} for 3.3V V_{CC} . One Buffer Output

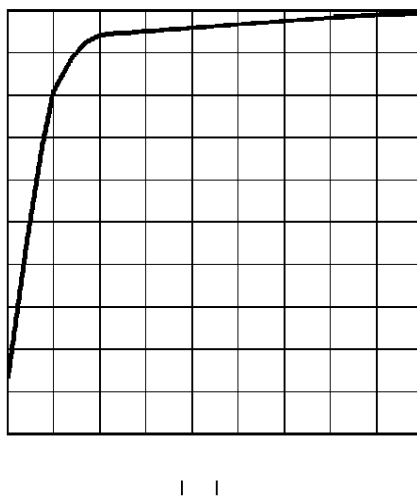

Figure 1b. Typical V_{OH} vs. I_{OH} for 3.3V V_{CC} . One Buffer Output

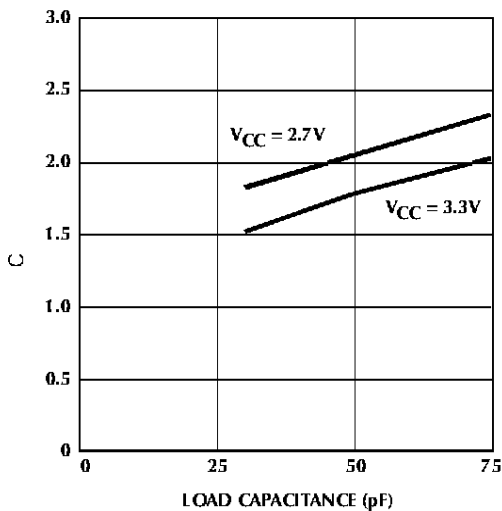

Figure 2a. Propagation Delay vs. Load Capacitance: 3.3V, 50MHz

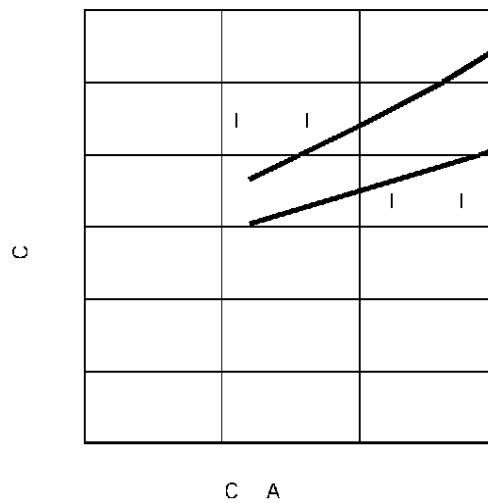

Figure 2b. Propagation Delay vs. Load Capacitance: 2.7V, 50MHz

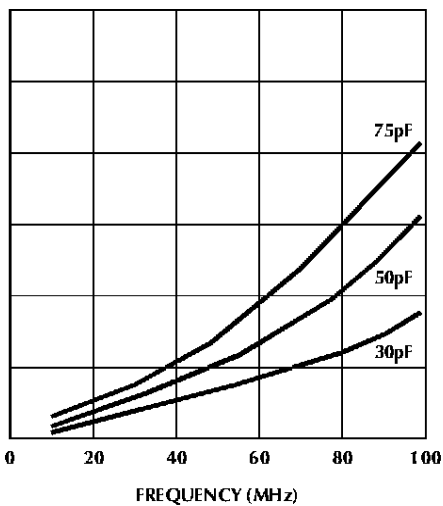

Figure 3a. I_{CC} vs. Frequency: $V_{CC} = V_{IN} = 3.3V$. One Buffer Output

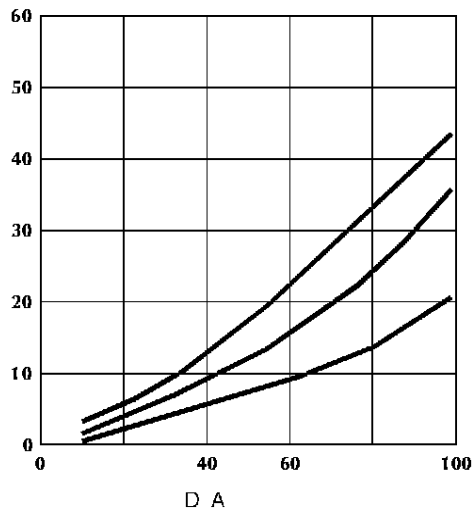

Figure 3b. I_{CC} vs. Frequency: $V_{CC} = V_{IN} = 2.7V$. One Buffer Output

FUNCTIONAL DESCRIPTION

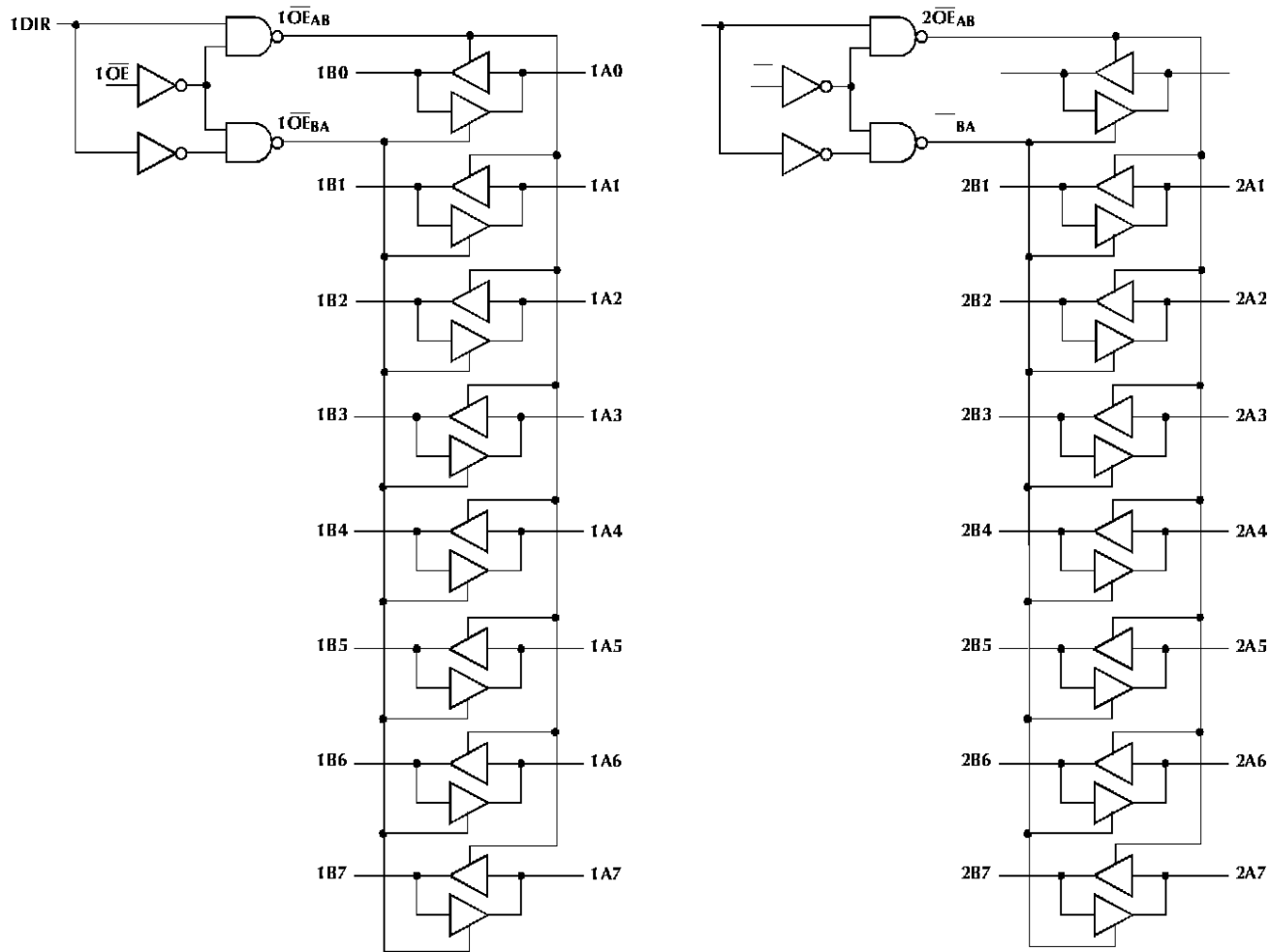

Figure 4. Logic Diagram

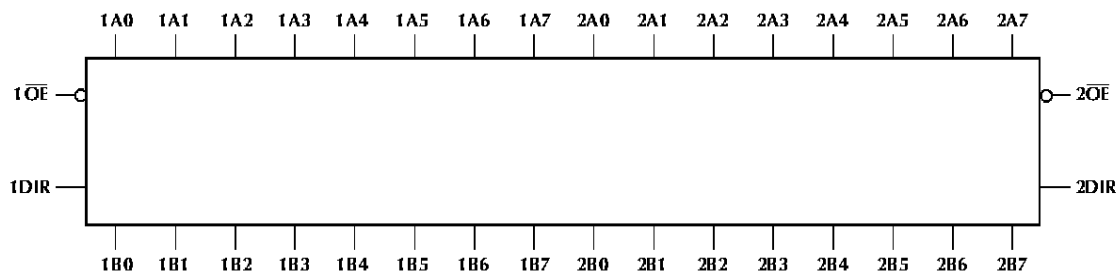

Figure 5. Logic Symbol

ARCHITECTURAL DESCRIPTION

The ML65F16245 is a 16-bit (dual-octal) non-inverting bus transceiver with 3-state outputs designed for 2.7V to 3.6V V_{CC} operation. This device is designed for asynchronous communication between data buses. The ML65F16245 can be used as two 8-bit transceivers or as one 16-bit transceiver and can be designated as Port-A bus and Port-B bus. The Direction and Output Enable controls are designed to operate these configurations. The direction control pin (iDIR) controls the direction of the data flow. The output enable pin ($1\overline{OE}$, $2\overline{OE}$) overrides the direction control and disables both ports.

Until now, these transceivers were typically implemented in CMOS logic and made to be TTL compatible by sizing the input devices appropriately. In order to buffer large capacitances with CMOS logic, it is necessary to cascade an even number of inverters, each successive inverter larger than the preceding, eventually leading to an inverter that will drive the required load capacitance at the required frequency. Each inverter stage represents an additional delay in the gating process because in order for a single gate to switch, the input must slew more than half of the supply voltage. The best of these 16-bit CMOS buffers has managed to drive 50pF load capacitance with a delay of 3ns.

Micro Linear has produced a 16-bit transceiver with a delay less than 2ns (at 3.3V) by using a unique circuit architecture that does not require cascade logic gates.

The basic architecture of the ML65F16245 is shown in Figure 6. In this circuit, there are two paths to the output. One path sources current to the load capacitance where the signal is asserted, and the other path sinks current from the output when the signal is negated.

The assertion path is the Darlington pair consisting of transistors Q1 and Q2. The effect of transistor Q1 is to increase the current gain through the stage from input to output, to increase the input resistance and to reduce input capacitance. During the transition state (the input from low-to-high) the output transistor Q2 sources large amount of current to quickly charge up a highly capacitive load which in effect reduces the bus settling time. This current is specified as $I_{DYNAMIC}$.

The negation path is also the Darlington pair consisting of transistor Q3 and transistor Q4. With M1 connecting to the input of the Darlington pair, Transistor Q4 then sinks a large amount of current during the input transition from high-to-low.

Inverter X2 is a helpful buffer that not only drives the output toward the upper rail but also pulls the output to the lower rail.

There are a number of MOSFETs not shown in Figure 6. These MOSFETs are used to 3-state the buffers.

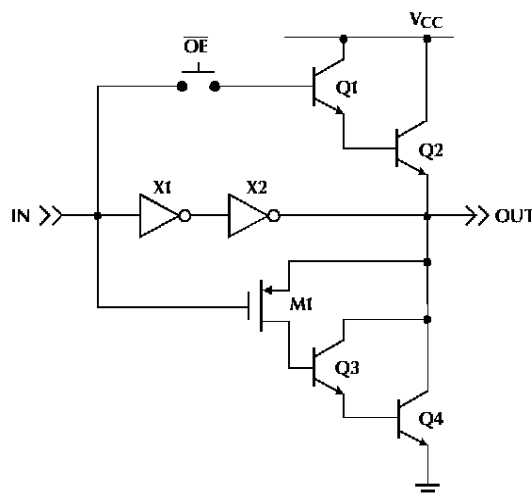

Figure 6. One Buffer Cell of the ML65F16245

CIRCUITS AND WAVE FORMS

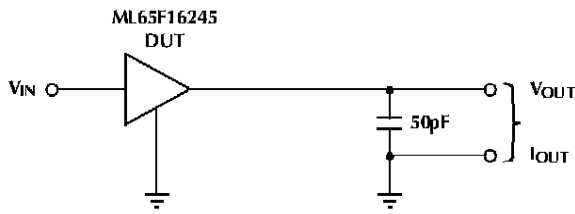

Figure 7. Test Circuits for All Outputs

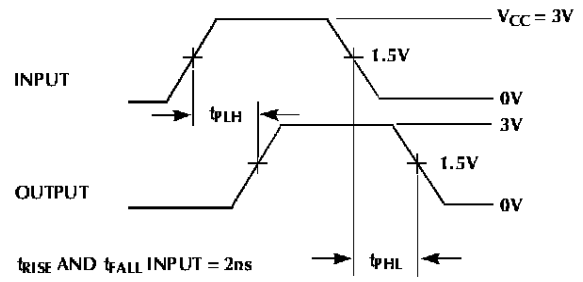

Figure 8. Propagation Delay

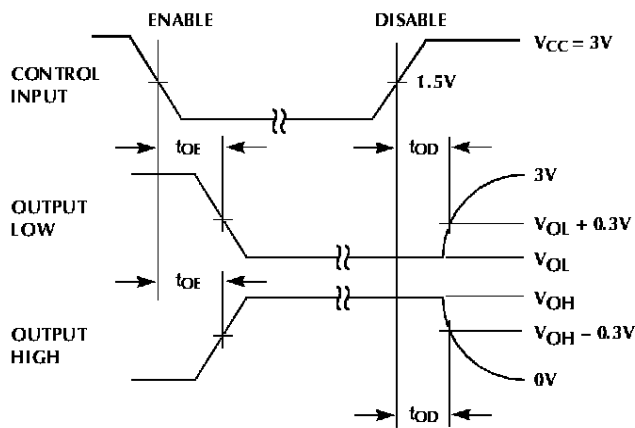

Figure 9. Enable and Disable Times

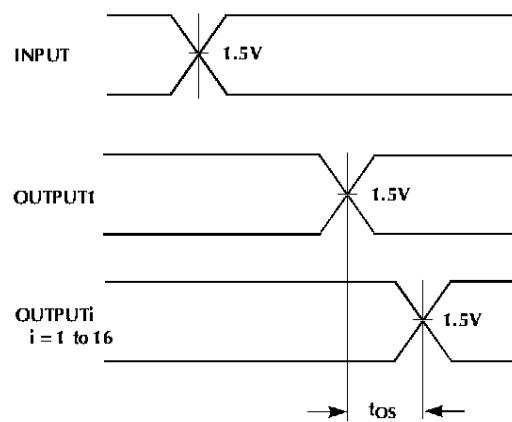
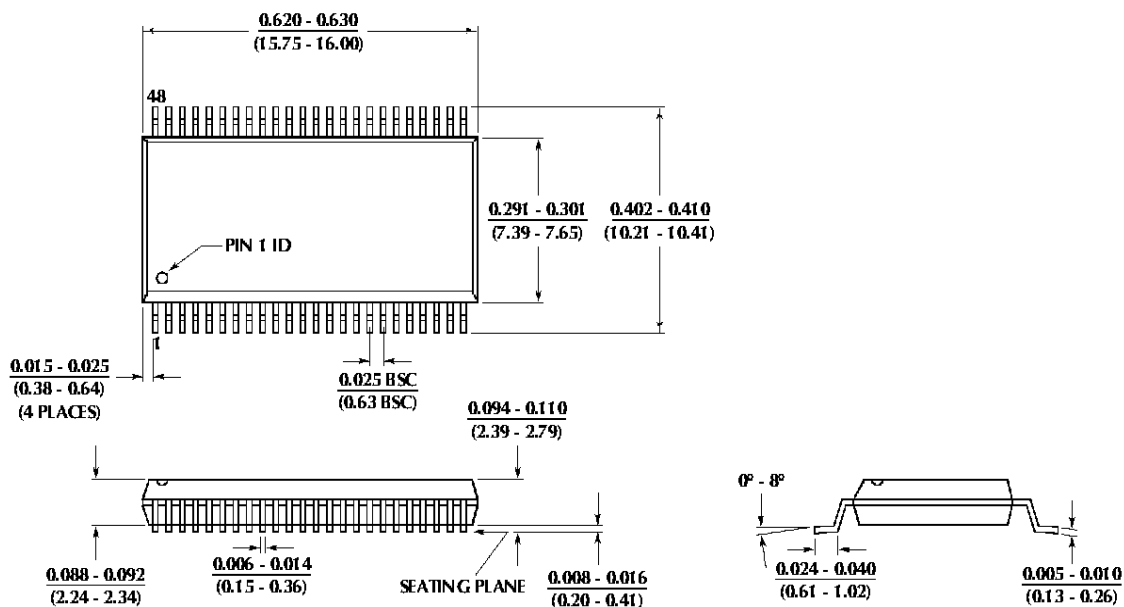

Figure 10. Output Skew

PHYSICAL DIMENSIONS inches (millimeters)

Package: R48
48-Pin SSOP



Package: T48
48-Pin TSSOP

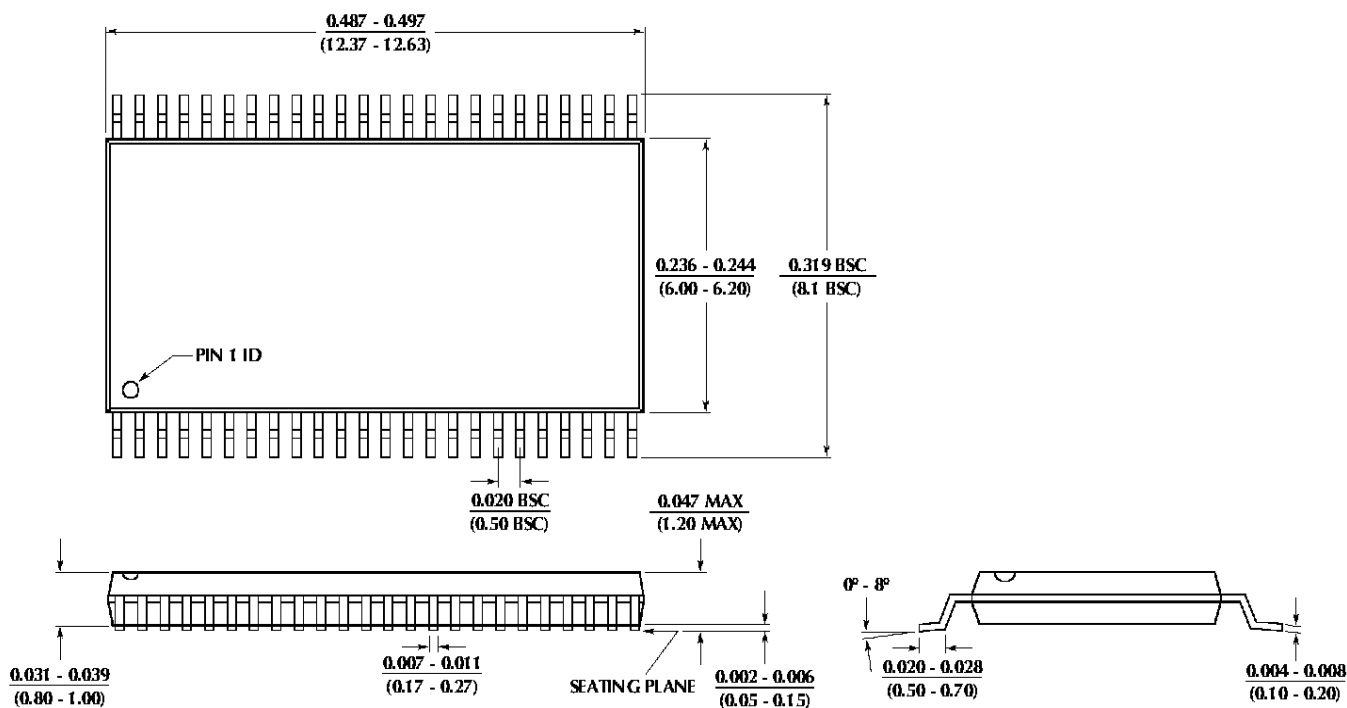

ORDERING INFORMATION

PART NUMBER	TEMPERATURE RANGE	PACKAGE
ML65F16245CR	0°C to 70°C	48-Pin SSOP (R48)
ML65F16245CT	0°C to 70°C	48-Pin TSSOP (T48)

© MicroLinear 1998.  **Micro Linear** is a registered trademark of MicroLinear Corporation. All other trademarks are the property of their respective owners.

Products described herein may be covered by one or more of the following U.S. patents: 4,897,611; 4,964,026; 5,027,116; 5,281,862; 5,283,483; 5,418,502; 5,508,570; 5,510,727; 5,523,940; 5,546,017; 5,559,470; 5,565,761; 5,592,128; 5,594,376; 5,652,479; 5,661,427; 5,663,874; 5,672,959; 5,689,167; 5,714,897; 5,717,798; 5,742,151; 5,747,977; 5,754,012; 5,757,174; 5,767,653; Japan: 2,598,946; 2,619,299; 2,704,176. Other patents are pending.

MicroLinear reserves the right to make changes to any product herein to improve reliability, function or design. MicroLinear does not assume any liability arising out of the application or use of any product described herein, neither does it convey any license under its patent right nor the rights of others. The circuits contained in this data sheet are offered as possible applications only. MicroLinear makes no warranties or representations as to whether the illustrated circuits infringe any intellectual property rights of others, and will accept no responsibility or liability for use of any application herein. The customer is urged to consult with appropriate legal counsel before deciding on a particular application.

2092 Concourse Drive
San Jose, CA 95131
Tel: (408) 433-5200
Fax: (408) 432-0295
www.microlinear.com



To receive a price quote or to request a product sample, call or send e-mail to your local representative.

When sending e-mail, be sure to include the Micro Linear part number and whether you want a price quote or a sample in the subject line.

(i.e. subject: Sample request - ML part#xxxx)

Click here to find your local representative

