

Vertical Cavity Surface Emitting Laser in ST Optical Sub-Assembly



OPV215AT, OPV215BT, OPV215YAT, OPV215YBT

Features

- Attenuated for noise reduction
- 850 nm VCSEL technology
- High thermal stability
- Up to 1.25 Gbps
- Recommended for multimode fiber applications
- Microbead lens
- Burned in for communication level reliability
- High optical coupling to MM fiber
- ST* style receptacle

Description

The OPV215AT and OPV215BT are high performance 850nm VCSEL packaged for high speed communication links. OPV215AT and OPV215BT combines all the performance advantages of a VCSEL with the addition of a power monitor diode for precise control of optical power and about 30% optical attenuation for noise suppression.

The OPV215YAT and OPV215YBT are identical electrically and optically and differ only in pin out. Refer to mechanical drawings for details.

This product's combination of features including high speed, high output power and optical attenuation make it an ideal transmitter for integration into all types of data communications equipment.

Applications include:

- ◆ Fibre Channel
- ◆ Gigabit Ethernet
- ◆ ATM
- ◆ VSR (Very Short Reach)
- ◆ Intra-system links
- ◆ Optical backplane interconnects.

* - ST is a registered trademark of AT&T

Technical Data

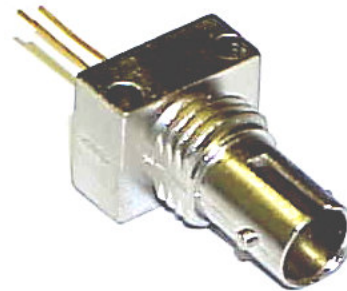

Absolute Maximum Ratings (T_A = 25° C unless otherwise noted)

Storage Temperature	-40° C to +125° C
Operating Temperature	-40° C to +85° C
Soldering Lead Temperature	260° C for 10 Seconds
Maximum Forward Peak Current	30 mA
Maximum Reverse Voltage	5 V



Additional laser safety information can be found on the Optek website. See application #221. Classification is not marked on the device due to space limitations. See package outline for centerline of optical radiance. Operating devices beyond maximum rating may cause devices to exceed rated classification

October 2003
Issue 3.3

OPV215AT, OPV215BT, OPV215YAT, OPV215YBT Technical Data



Electrical/Optical Characteristics (at 25 °C unless otherwise specified)

SYMBOL	PARAMETER	MIN	TYP	MAX	UNITS	TEST CONDITION
P _{T50}	Total Coupled Power 50/125 μm Fiber	400			μW	I _F = 12 mA
		200			μW	I _F = 12 mA
I _{TH}	Threshold Current	2.0		5.5	mA	Note 1
V _F	Forward Voltage	1.7		2.15	V	I _F = 12 mA
I _R	Reverse Current			30	nA	V _R = 5 V
R _S	Series Resistance	14		40	ohms	Note 2
η	Slope Efficiency	40			μW/mA	Note 3
		20			μW/mA	Note 3
I _{RPD}	Reverse Current, photo diode			30	nA	V _R = 5 V
I _M	Monitor Current	30			μA	I _F = 12 mA
λ	Wavelength	830		860	nm	
Δλ	Optical Bandwidth			0.85	nm	
t _r , t _f	Rise and Fall Time		200		ps	20% to 80%
N _{RI}	Relative Intensity Noise		-123		db/Hz	
Δη/ΔT	Temp Coefficient of Slope Efficiency		-0.4		%/°C	(0° - 70° C)
ΔI _{TH} /ΔT	Temp Coefficient of Threshold Current		±1.5		mA	0° - 70° C
Δλ/ΔT	Temp Coefficient of Wavelength		0.06		nm/°C	0° - 70° C
ΔV _f /ΔT	Temperature Coefficient for VF		-2.5		mV/°C	

NOTES:

- Threshold Current is based on the two line intersection method specified in Telcordia GR-468-Core. Line 1 from 6 mA to 8 mA. Line 2 from 0 mA to 2 mA.
- Series Resistance is the slope of the Voltage-Current line from 8 mA to 12 mA.
- Slope efficiency, is the slope of the best fit LI line from 8 mA to 12mA using no larger than .5 mA test interval points. Measured with a 50/125 μm fiber.

October 2003
Issue 3.3

Optek reserves the right to make changes at any time in order to improve design and to supply the best product possible.

Optek Technology, Inc.

Carrollton, Texas 75006

(972) 323-2200

sensors@optekinc.com

www.optekinc.com

OPV215AT, OPV215BT, OPV215YAT, OPV215YBT Technical Data



Coupled Power vs. Forward Current

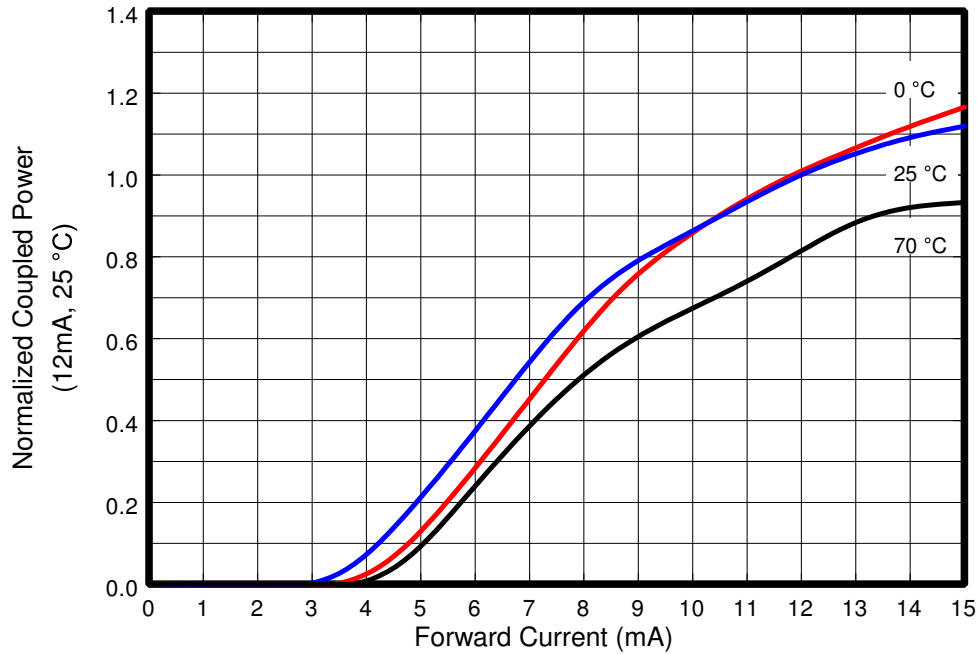

Forward Voltage vs. Forward Current

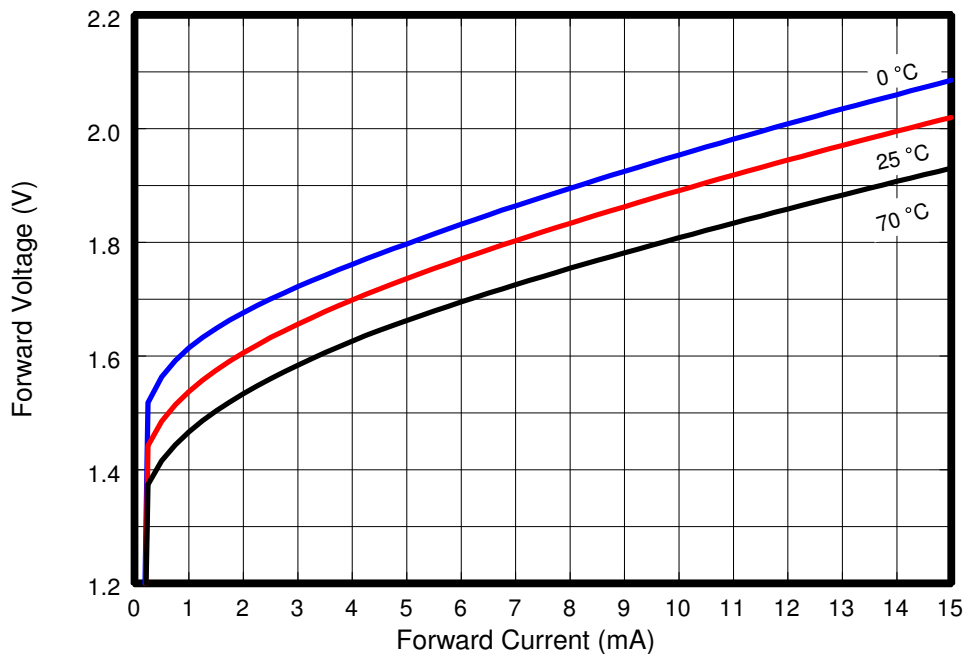

October 2003
Issue 3.3

Optek reserves the right to make changes at any time in order to improve design and to supply the best product possible.

Optek Technology, Inc.

Carrollton, Texas 75006

(972) 323-2200

sensors@optekinc.com

www.optekinc.com

OPV215AT, OPV215BT, OPV215YAT, OPV215YBT Technical Data

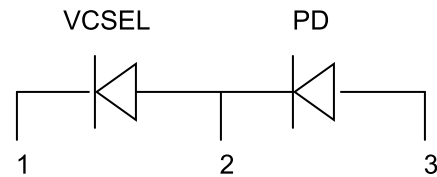
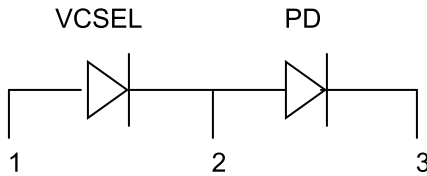
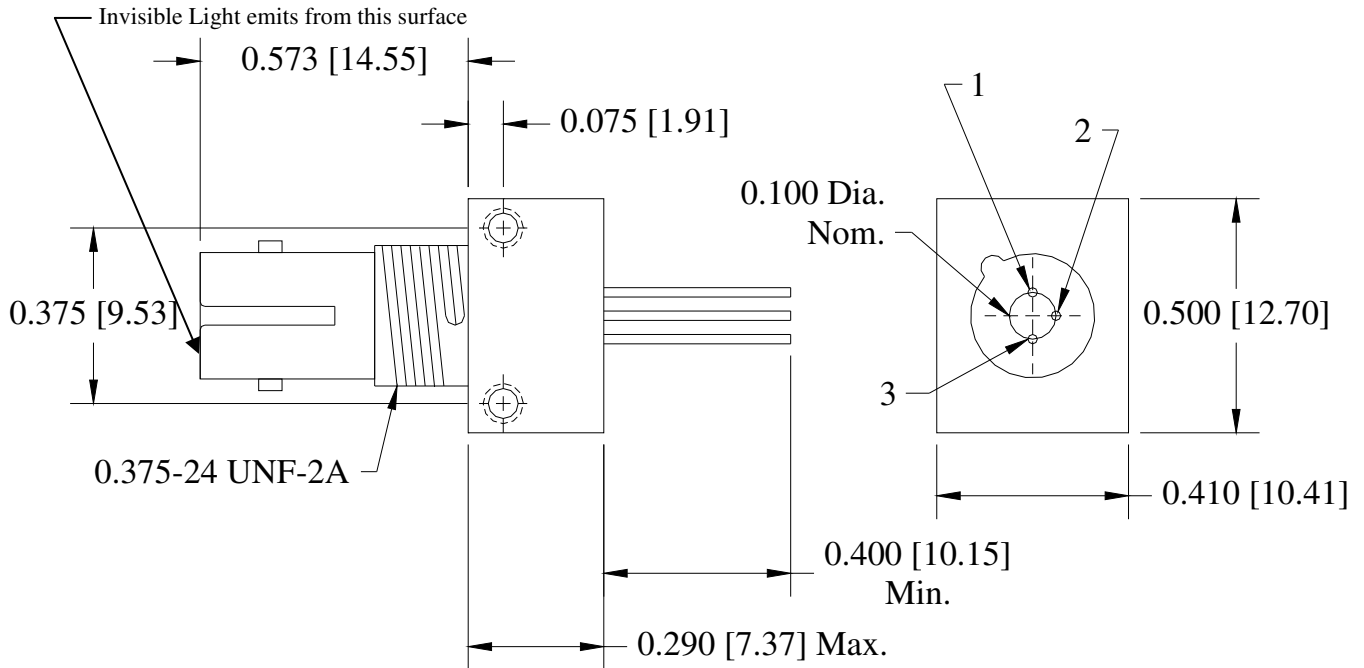

OPV215AT, OPV215BT	
Pin	Connection
1	VCSEL Anode
2	VCSEL Cathode/PD Anode
3	PD Cathode

OPV215YAT, OPV215YBT	
Pin	Connection
1	VCSEL Cathode
2	VCSEL Anode/PD Cathode
3	PD Anode

July 2002
OPV215T, Rev. -

October 2003
Issue 3.3

Optek reserves the right to make changes at any time in order to improve design and to supply the best product possible.

Optek Technology, Inc.

Carrollton, Texas 75006

(972) 323-2200

sensors@optekinc.com

www.optekinc.com