

NN514405A / NN514405Bseries

EDO (Hyper Page) Mode

CMOS 1M × 4bit Dynamic RAM



DESCRIPTION

The NN514405A/B series is a high performance CMOS Dynamic Random Access Memory organized as 1,048,576 words by 4-bits.

The NN514405A/B series is fabricated with advanced CMOS technology and designed with innovative design techniques resulting in high speed, extremely low power and wide operating margins at both component and system levels.

The NN514405A/B series features an EDO (Hyper page) mode operation in which a high speed read, write or read-write is performed on any column address along a row address.

An extremely short row address capture time and an asynchronous column address decoder relax the timing constraints associated with address multiplexing.

Refresh is accomplished by performing $\overline{\text{RAS}}$ only refresh cycles, hidden refresh cycles, $\overline{\text{CAS}}$ before $\overline{\text{RAS}}$ refresh cycles, or normal read or write cycles on the 1,024 address combinations of A0 to A9 during a 16 ms period.

Multiplexed address inputs permit The NN514405A/B series to be packaged in a standard 26-pin plastic SOJ, 26 pin TSOP TYPE II. The package sizes provide high system bit densities and are compatible with widely available automated testing and insertion equipment. System level features include single power supply of 5V ±10% tolerance and direct interface with high performance TTL logic families.

FEATURES

- 1,048,576 × 4 bit Organization
- Single 5V ±10% Power Supply
- Performance Ranges

Parameter	-45	-50	-60	-70
Max. $\overline{\text{RAS}}$ Access Time (t_{RAC})	45ns	50ns	60ns	70ns
Max. $\overline{\text{CAS}}$ Access Time (t_{CAC})	13ns	13ns	15ns	20ns
Max. Column Address Access Time (t_{AA})	23ns	25ns	30ns	35ns
Min. Read/Write Cycle Time (t_{RC})	80ns	90ns	110ns	130ns

- EDO (Hyper Page) Mode Operation
- Low Power Operation
 - Low Standby Current (CMOS level inputs)
 - Standard 1mA
 - L version 50µA
- 1,024 Refresh Cycles
 - Standard distributed across 16ms
 - L version distributed across 128ms
- Self Refresh Mode (L version)
- All inputs/Outputs and Clocks fully TTL and CMOS compatible
- Refresh Modes
 - $\overline{\text{RAS}}$ only
 - $\overline{\text{CAS}}$ before $\overline{\text{RAS}}$
 - Hidden Refresh
- ×8 bit Test Mode
- High Reliability Packages
 - Plastic 26pin SOJ (P26/20SJ-2A)
 - Plastic 26pin TSOP TYPE II (P26/20TP-2A/R)

9005650 0001201 42T

PIN CONFIGURATION (TOP VIEW)

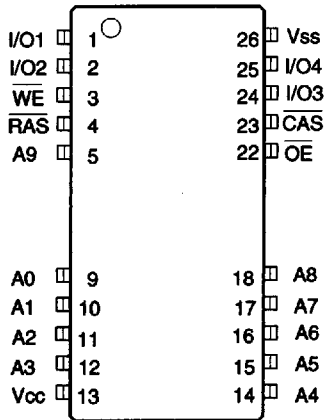

26/20-pin TSOP TYPE (II)
 Normal Bend (300 mil)
 P26/20TP-2A

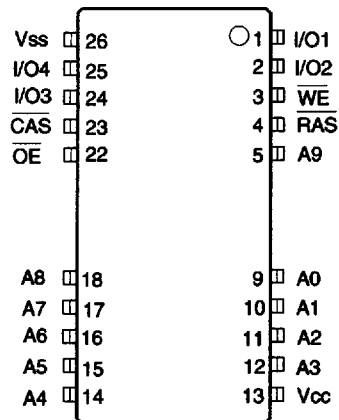

26/20-pin TSOP TYPE (II)
 Reverse Bend (300 mil)
 P26/20TP-2A-R

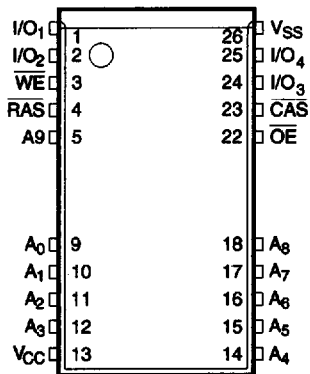

26/20-pin SOJ (300mil)
 P26/20SJ-2A

PIN NAMES

A ₀ -A ₉	Address Inputs
$\overline{\text{RAS}}$	Row Address Strobe
$\overline{\text{CAS}}$	Column Address Strobe
$\overline{\text{OE}}$	Output Enable
I/O ₁ -I/O ₄	Data-In / Data-out
$\overline{\text{WE}}$	Write Enable
V _{CC}	+5V Supply
V _{SS}	Ground
NC	No Connection

FUNCTIONAL BLOCK DIAGRAM

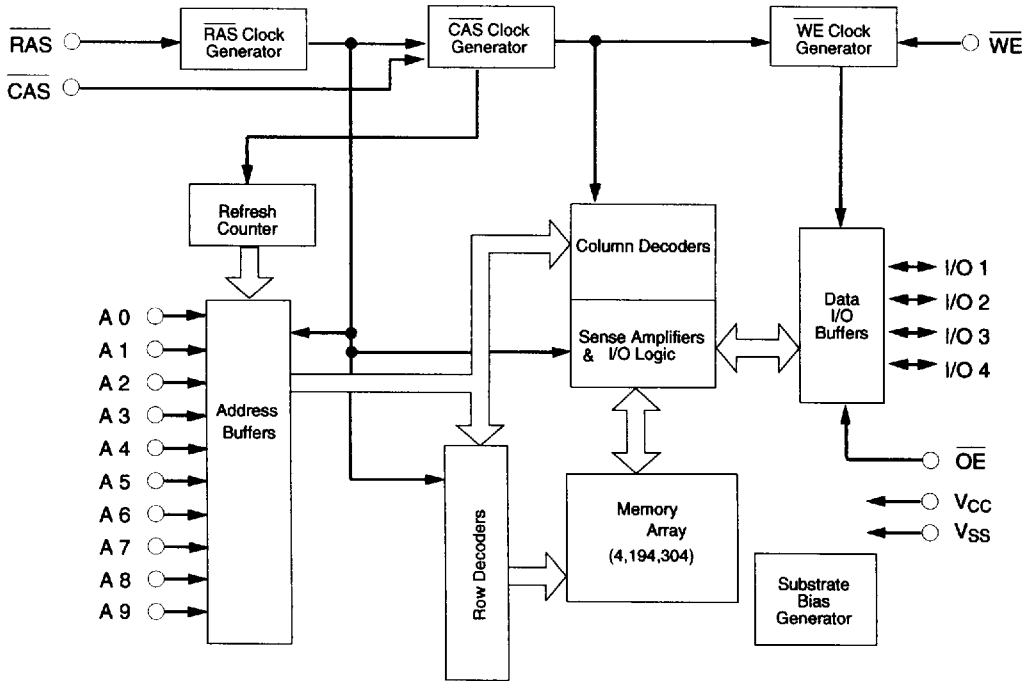

ABSOLUTE MAXIMUM RATINGS

RATING	SYMBOL	VALUE	UNIT
Voltage on Any Pin Relative to V _{SS}	V _{in} , V _{out}	-1 to 7	V
Voltage on V _{CC} Relative to V _{SS}	V _{CC}	-1 to 7	V
Storage Temperature (Plastic)	T _{stg}	-55 to +125	°C
Power Dissipation	P _d	1.0	W
Ambient Operating Temperature	T _a	0 to +70	°C
Short Circuit Output Current	I _{out}	50	mA

Permanent device damage can occur if absolute maximum ratings are exceeded. Functional operation should be restricted to the conditions as detailed in the operational sections of this data sheet. Exposure to absolute maximum rating conditions for extended periods can affect device reliability.

DC OPERATING CONDITIONS

SYMBOL	PARAMETER	MIN.	TYP.	MAX.	UNIT
V _{CC}	Supply Voltage	4.5	5.0	5.5	V
V _{SS}	Supply Voltage	0	0	0	V
V _{IH}	Input High Voltage, All Inputs	2.4	—	6.5	V
V _{IL}	Input Low Voltage, All Inputs	-1.0	—	0.8	V

Note: All voltage values in this data sheet are with respect to V_{SS} unless otherwise specified.

DC ELECTRICAL CHARACTERISTICS (0°C ≤ Ta ≤ 70°C, V_{CC} = 5.0V ±10%)
(NN514405A)

SYMBOL	PARAMETER	SPEED	MIN.	MAX.	UNIT	TEST CONDITIONS	NOTES
I _{CC1}	Operating Current	-45		130	mA	t _{RC} = t _{RC} (min.) RAS, CAS, Address cycling	1, 2
		-50		120	mA		
		-60		110	mA		
		-70		100	mA		
I _{CC2}	Standby Current			1.0	mA	RAS = CAS ≥ (V _{CC} - 0.2V)	
				2.0	mA	RAS = CAS ≥ V _{IH}	
I _{CC2}	Standby Current (L version)			50	μA	RAS = CAS ≥ (V _{CC} - 0.2V) All other inputs are stable at (V _{CC} - 0.2V) or (V _{SS} + 0.2V)	
I _{CC3}	Refresh Current (RAS only refresh)	-45		130	mA	t _{RC} = t _{RC} (min.) RAS cycling, CAS = V _{IH}	1
		-50		120	mA		
		-60		110	mA		
		-70		100	mA		
I _{CC4}	EDO (Hyper) Page Mode Current	-45		105	mA	I _{HPC} = I _{HPC} (min.) RAS = V _{IL} CAS, Address cycling	1,2
		-50		100	mA		
		-60		90	mA		
		-70		80	mA		
I _{CC5}	Refresh Current (CAS before RAS refresh)	-45		130	mA	t _{RC} = t _{RC} (min.) RAS, CAS cycling	1
		-50		120	mA		
		-60		110	mA		
		-70		100	mA		
I _{CC6}	Refresh Current (CAS before RAS refresh)			150	μA	1024 cycles / 128ms t _{RAS} ≤ 200ns, WE ≥ (V _{CC} - 0.2V) All other inputs are stable at (V _{CC} - 0.2V) or (V _{SS} + 0.2V)	
I _{CC7}	Self Refresh Mode Current			100	μA	RAS = CAS ≥ (V _{SS} + 0.2V) All other input high levels are (V _{CC} - 0.2V) or input low levels are (V _{SS} + 0.2V)	
I _{L1}	Input Leakage Current (Any input pin)		-10	10	μA	0V ≤ V _{IH} ≤ 5.5V, Others = 0V	
I _{L0}	Output Leakage Current (For high impedance state)		-10	10	μA	RAS ≥ V _{IH} (min), CAS ≥ V _{IH} (min) 0V ≤ V _{OUT} ≤ 5.5V	
V _{OH}	Output High Voltage		2.4		V	I _{OH} = -5.0 mA	
V _{OL}	Output Low Voltage			0.4	V	I _{OL} = 4.2 mA	

Notes: 1. I_{CC1}, I_{CC3}, I_{CC4} and I_{CC5} depend on cycle rate.
 2. I_{CC1} and I_{CC4} depend on output loading. Specified values are obtained with the outputs open.

CAPACITANCE (0°C ≤ Ta ≤ 70°C, V_{CC} = 5.0V ±10%, f = 1MHz)

SYMBOL	PARAMETER	MIN.	MAX.	UNIT
C _{IN1}	Address(A0 ~ A9)	—	5	pF
C _{IN2}	RAS, CAS, WE, OE	—	5	pF
C _{OUT}	I/O1, I/O2, I/O3, I/O4	—	7	pF

9005650 0001204 139

DC ELECTRICAL CHARACTERISTICS (0°C ≤ Ta ≤ 70°C, V_{CC} = 5.0V ±10%)
(NN514405B)

SYMBOL	PARAMETER	SPEED	MIN.	MAX.	UNIT	TEST CONDITIONS	NOTES
I _{CC1}	Operating Current	-45		100	mA	t _{RC} = t _{RC} (min.) RAS, CAS, Address cycling	1, 2
		-50		90	mA		
		-60		80	mA		
		-70		70	mA		
I _{CC2}	Standby Current			1.0	mA	RAS = CAS ≥ (V _{CC} - 0.2V)	
				2.0	mA	RAS = CAS ≥ V _{IH}	
I _{CC2}	Standby Current (L version)			150	μA	RAS = CAS ≥ (V _{CC} - 0.2V) All other inputs are stable at (V _{CC} - 0.2V) or (V _{SS} + 0.2V)	
I _{CC3}	Refresh Current (RAS only refresh)	-45		100	mA	t _{RC} = t _{RC} (min.) RAS cycling, CAS = V _{IH}	1
		-50		90	mA		
		-60		80	mA		
		-70		70	mA		
I _{CC4}	EDO (Hyper) Page Mode Current	-45		70	mA	t _{HPC} = t _{HPC} (min.) RAS = V _{IL} CAS, Address cycling	1,2
		-50		60	mA		
		-60		50	mA		
		-70		40	mA		
I _{CC5}	Refresh Current (CAS before RAS refresh)	-45		100	mA	t _{RC} = t _{RC} (min.) RAS, CAS cycling	1
		-50		90	mA		
		-60		80	mA		
		-70		70	mA		
I _{CC6}	Refresh Current (NN514405BL: CAS before RAS refresh)			200	μA	1024 cycles / 128ms t _{RAS} ≤ 200ns, WE ≥ (V _{CC} - 0.2V) All other inputs are stable at (V _{CC} - 0.2V) or (V _{SS} + 0.2V)	
I _{CC7}	Self Refresh Mode Current			200	μA	RAS = CAS ≤ (V _{SS} + 0.2V) All other input high levels are (V _{CC} - 0.2V) or input low levels are (V _{SS} + 0.2V)	
I _{L1,I}	Input Leakage Current (Any input pin)		-10	10	μA	0V ≤ V _{IH} ≤ 5.5V, Others = 0V	
I _{L0,I}	Output Leakage Current (For high impedance state)		-10	10	μA	RAS ≥ V _{IH} (min), CAS ≥ V _{IH} (min) 0V ≤ V _{OUT} ≤ 5.5V	
V _{OH}	Output High Voltage		2.4		V	I _{OH} = -5.0 mA	
V _{OL}	Output Low Voltage			0.4	V	I _{OL} = 4.2 mA	

- Notes: 1. I_{CC1}, I_{CC3}, I_{CC4} and I_{CC5} depend on cycle rate.
2. I_{CC1} and I_{CC4} depend on output loading. Specified values are obtained with the outputs open.

CAPACITANCE (0°C ≤ Ta ≤ 70°C, V_{CC} = 5.0V ±10%, f = 1MHz)

SYMBOL	PARAMETER	MIN.	MAX.	UNIT
C _{IN1}	Address(A0 ~ A9)	—	5	pF
C _{IN2}	RAS, CAS, WE, OE	—	5	pF
C _{OUT}	I/O1, I/O2, I/O3, I/O4	—	7	pF

A.C. OPERATING CONDITIONS (0 °C ≤ T_a ≤ 70 °C, V_{CC} = 5 V ± 10%, V_{SS} = 0 V) (NOTES 3, 4, 5)

NO.	NOTES		PARAMETER	-45		-50		-60		-70		UNIT	NOTE
	JEDEC	STD.		MIN.	MAX.	MIN.	MAX.	MIN.	MAX.	MIN.	MAX.		
1	t _{CL1QV}	t _{CAC}	Access Time from CAS	—	13	—	13	—	15	—	20	ns	6,13
2	t _{CH2QV}	t _{CPA}	Access Time from CAS Precharge	—	28	—	30	—	35	—	40	ns	13,14
3	t _{AVQV}	t _{AA}	Access Time from Column Address	—	23	—	25	—	30	—	35	ns	7,13
4	t _{RL1QV}	t _{RAC}	Access Time from RAS	—	45	—	50	—	60	—	70	ns	6,7
5	t _{RL1CH1}	t _{CSH}	CAS Hold Time	45	—	50	—	60	—	70	—	ns	
6	t _{RL1CX}	t _{CHS}	CAS Hold Time (Self Refresh Mode)	-50	—	-50	—	-50	—	-50	—	ns	
7	t _{RL1CH1}	t _{CHR}	CAS Hold Time (CAS before RAS Refresh)	10	—	10	—	10	—	10	—	ns	
8	t _{CH2CL2}	t _{CPN}	CAS Precharge Time (CAS before RAS Refresh)	8	—	8	—	10	—	10	—	ns	
9	t _{CH2CL2}	t _{CP}	CAS Precharge Time	5	—	5	—	5	—	5	—	ns	14
10	t _{CL1CH1}	t _{CAS}	CAS Pulse Width	8	100K	8	100K	10	100K	15	100K	ns	
11	t _{CL1RL2}	t _{CSR}	CAS Setup Time (CAS before RAS Refresh)	5	—	5	—	5	—	5	—	ns	
12	t _{CL1QX}	t _{CLZ}	CAS to Output in Low-Z	0	—	0	—	0	—	0	—	ns	8
13	t _{CH2RL2}	t _{CRP}	CAS to RAS Precharge Time	5	—	5	—	5	—	5	—	ns	
14	t _{CL1WL2}	t _{CWD}	CAS to WE Delay Time	28	—	30	—	32	—	50	—	ns	11
15	t _{CL1AX}	t _{CAH}	Column Address Hold Time	8	—	8	—	10	—	15	—	ns	
16	t _{RL1AX}	t _{AR}	Column Address Hold Time Referenced to RAS	30	—	35	—	40	—	40	—	ns	
17	t _{AVCL2}	t _{ASC}	Column Address Setup Time	0	—	0	—	0	—	0	—	ns	14
18	t _{AVCH1}	t _{CAL}	Column Address to CAS Lead Time	13	—	13	—	18	—	23	—	ns	
19	t _{AVRH1}	t _{RAL}	Column Address to RAS Lead Time	22	—	24	—	30	—	35	—	ns	
20	t _{AVWL2}	t _{AWD}	Column Address to WE Delay Time	41	—	42	—	58	—	65	—	ns	11
21	t _{CL1DX} t _{WL1DX}	t _{DH}	Data Hold Time	8	—	10	—	10	—	10	—	ns	12
22	t _{CL2QX}	t _{DHC}	Data Output Hold Time	0	—	0	—	0	—	0	—	ns	
23	t _{DVCL2} t _{DVWL2}	t _{DS}	Data Setup Time	0	—	0	—	0	—	0	—	ns	12
24	t _{OL1QV}	t _{OEa}	OE Access Time	—	13	—	13	—	15	—	20	ns	
25	t _{WL1OL2}	t _{OEh}	OE Command Hold Time	15	—	15	—	15	—	20	—	ns	
26	t _{GH2GL2}	t _{OPZ}	OE Pulse Width for Output Disable When CAS High	5	—	7	—	7	—	7	—	ns	
27	t _{GL1CH1}	t _{OCS}	OE Setup Time to CAS High	5	—	7	—	7	—	7	—	ns	
28	t _{GL1RH1}	t _{ORS}	OE Setup Time to RAS High	5	—	7	—	7	—	7	—	ns	
29	t _{CH2QV}	t _{OED}	OE to Data Delay Time	10	—	10	—	10	—	10	—	ns	
30	t _{GL2QX}	t _{OLZ}	OE to Output in low-Z	0	—	0	—	0	—	0	—	ns	
31	t _{CH2QZ}	t _{OFF}	Output Buffer Turn-off Delay Time	0	12	0	13	0	15	0	15	ns	10
32	t _{CH2QX}	t _{OEZ}	Output Buffer Turn-off Delay Time Referenced to OE	0	10	0	10	0	15	0	15	ns	
33	t _{FRHQZ}	t _{OFFR}	Output Buffer Turn-off Delay Time Referenced to RAS	0	23	0	25	0	25	0	25	ns	16
34	t _{WL2QZ}	t _{WEZ}	Output Buffer Turn-off Delay Time Referenced to WE	0	12	0	13	0	15	0	15	ns	

NO.	SYMBOL		PARAMETER	-45		-50		-60		-70		UNIT	NOTE
	JEDEC	STD.		MIN.	MAX.	MIN.	MAX.	MIN.	MAX.	MIN.	MAX.		
35	t _{CL1RH1}	t _{RSH}	RAS Hold Time	15	—	15	—	15	—	20	—	ns	
36	t _{OL1RH1}	t _{ROH}	RAS Hold Time Referenced to OE	10	—	10	—	10	—	10	—	ns	
37	t _{CH2RH1}	t _{RHCP}	RAS Hold Time Referenced CAS Precharge	28	—	30	—	35	—	40	—	ns	
38	t _{RH2RL2}	t _{RP}	RAS Precharge Time	25	—	25	—	30	—	40	—	ns	
39	t _{RH2RL2}	t _{RPS}	RAS Precharge Time (Self Refresh Mode)	80	—	90	—	110	—	130	—		
40	t _{RL1RH1}	t _{RAS}	RAS Pulse Width	45	100K	50	100K	60	100K	70	100K	ns	
41	t _{RL1RH1}	t _{RASS}	RAS Pulse Width (Self Refresh Mode)	300	—	300	—	300	—	300	—	μs	
42	t _{RL1RH1}	t _{RASP}	RAS Pulse Width (EDO (Hyper Page) Mode)	45	100K	50	100K	60	100K	70	100K	ns	
43	t _{RL1CL1}	t _{RCD}	RAS to CAS Delay Time	13	30	13	35	13	45	13	50	ns	6
44	t _{RH2CL2}	t _{RPC}	RAS to CAS Precharge Time	10	—	10	—	10	—	10	—	ns	
45	t _{RL1AV}	t _{RAD}	RAS to Column Address Delay Time	11	20	11	23	11	30	11	35	ns	7
46	t _{RL2QX}	t _{RLZ}	RAS To Output in Low-Z	0	—	0	—	0	—	0	—	ns	
47	t _{RL1WL2}	t _{RWD}	RAS to WE Delay Time	75	—	80	—	85	—	100	—	ns	11
48	t _{CH2WL2}	t _{RCH}	Read Command Hold Time	0	—	0	—	0	—	0	—	ns	9
49	t _{RH2WL2}	t _{RRH}	Read Command Hold Time Referenced to RAS	5	—	5	—	5	—	5	—	ns	9
50	t _{WH2CL2}	t _{RCS}	Read Command Setup Time	0	—	0	—	0	—	0	—	ns	
51	t _{RL2RL2}	t _{RC}	Random Read or Write Cycle Time	80	—	90	—	110	—	130	—	ns	
52	t _{CL2CL2}	t _{HPC}	Read or Write Cycle Time (EDO (Hyper Page) Mode)	20	—	20	—	25	—	30	—	ns	13,14
53	t _{RL2RL2}	t _{RMW}	Read-Modify-Write Cycle Time	120	—	125	—	135	—	185	—	ns	
54	t _{CL2CL2}	t _{PRMW}	Read-Modify-Write Cycle Time (EDO (Hyper Page) Mode)	57	—	57	—	66	—	100	—	ns	13,14
55	t _{REF}	t _{REF}	Refresh Period	—	16	—	16	—	16	—	16	ms	15
56	t _{RL1AX}	t _{RAH}	Row Address Hold Time	8	—	8	—	8	—	8	—	ns	
57	t _{AVRL2}	t _{ASR}	Row Address Setup Time	0	—	0	—	0	—	0	—	ns	
58	t _T	t _T	Transition Time (Rise and Fall)	2	50	2	50	2	50	2	50	ns	4,5
59	t _{WL1WH1}	t _{WPZ}	WE Pulse Width for Disable When CAS High	5	—	7	—	7	—	7	—	ns	
60	t _{CL1WH1}	t _{WCH}	Write Command Hold Time	8	—	8	—	10	—	15	—	ns	
61	t _{WL1WH1}	t _{WP}	Write Command Pulse Width	8	—	8	—	10	—	15	—	ns	
62	t _{WL1CL2}	t _{WCS}	Write Command Setup Time	0	—	0	—	0	—	0	—	ns	11
63	t _{WL1CH1}	t _{CWL}	Write Command to CAS Lead Time	15	—	15	—	15	—	20	—	ns	
64	t _{WL1RH1}	t _{RWL}	Write Command to RAS Lead Time	15	—	15	—	15	—	20	—	ns	
65	t _{WL1RL2}	t _{WSR}	Write Command Setup Time (Test Mode)	10	—	10	—	10	—	10	—	ns	
66	t _{RL1WH1}	t _{WHR}	Write Command Hold Time (Test Mode)	10	—	10	—	10	—	10	—	ns	
67	t _{WH2RL2}	t _{WRP}	WE to RAS Precharge Time (CAS before RAS)	10	—	10	—	10	—	10	—	ns	
68	t _{RL1WH2}	t _{WRH}	WE to RAS Hold Time (CAS before RAS)	10	—	10	—	10	—	10	—	ns	

9005650 0001207 948

Notes:

3. Eight Initialization Cycles are required following a 200 μ s pause after Power Up. These Initialization Cycles may consist of any combination of the following : $\overline{\text{RAS}}$ only refresh Cycles, Read Cycles, Write Cycles. $\overline{\text{CAS}}$ before $\overline{\text{RAS}}$ refresh Cycles.
4. AC measurements assume $t_r=3\text{ns}$. All AC parameters are measured with $V_{IL}(\text{min.}) \geq V_{SS}$ and $V_{IH}(\text{max.}) \leq V_{CC}$ and with a load equivalent to two TTL loads and 100pF.
5. $V_{IH}(\text{min.})$ and $V_{IL}(\text{max.})$ are reference levels for measuring timing of input signals. Also, transition times are measured between V_{IH} and V_{IL} .
6. Operation within the $t_{RCD}(\text{max.})$ limit ensures that $t_{RAC}(\text{max.})$ can be met. $t_{RCD}(\text{max.})$ is specified as a reference point only. If t_{RCD} is greater than the specified $t_{RCD}(\text{max.})$ limit, then access time is controlled by t_{CAC} .
7. Operation within the $t_{RAD}(\text{max.})$ limit ensures that $t_{RAC}(\text{max.})$ can be met. $t_{RAD}(\text{max.})$ is specified as a reference point only. If t_{RAD} is greater than the specified $t_{RAD}(\text{max.})$ limit, then access time is controlled by t_{AA} .
8. Assumes three state test load (5pF and a 220 ohm to 1.3V Thevenin equivalent).
9. Either t_{RCH} or t_{RRH} must be satisfied for a read cycle.
10. $t_{OFF}(\text{max.})$ defines the time at which the output achieves an open circuit condition and is not referenced to output voltage levels. t_{OFF} only applies when $\overline{\text{RAS}}$ is high.
11. t_{WCS} , t_{RWD} , t_{CWD} and t_{AWD} are not restrictive operating parameters. They are included in the data sheet as electrical characteristics only. If $t_{WCS} \geq t_{WCS}(\text{min.})$, the cycle is an early write cycle and data-out pins will remain open circuit (high impedance) throughout the entire cycle. If $t_{RWD} \geq t_{RWD}(\text{min.})$, $t_{CWD} \geq t_{CWD}(\text{min.})$ and $t_{AWD} \geq t_{AWD}(\text{min.})$, the cycle is a read-modify-write cycle and the data-out will contain data read from the selected cell. If neither of the above conditions is satisfied, the condition of the data-out (at access time) is indeterminate.
12. These parameters are referenced to $\overline{\text{CAS}}$ leading edge in early write cycles and to $\overline{\text{WE}}$ leading edge in read-modify-write cycles.
13. Access time is determined by the longer of t_{AA} , t_{CAC} , or t_{CPA} .
14. $t_{ASC} \geq t_{CP}$ to achieve $t_{PC}(\text{min.})$ and $t_{CPA}(\text{max.})$ values.
15. $t_{REF}=128\text{msec}$ for Long Refresh version (L version).
16. t_{OFF} applies only when $\overline{\text{CAS}}$ is high.

READ CYCLE

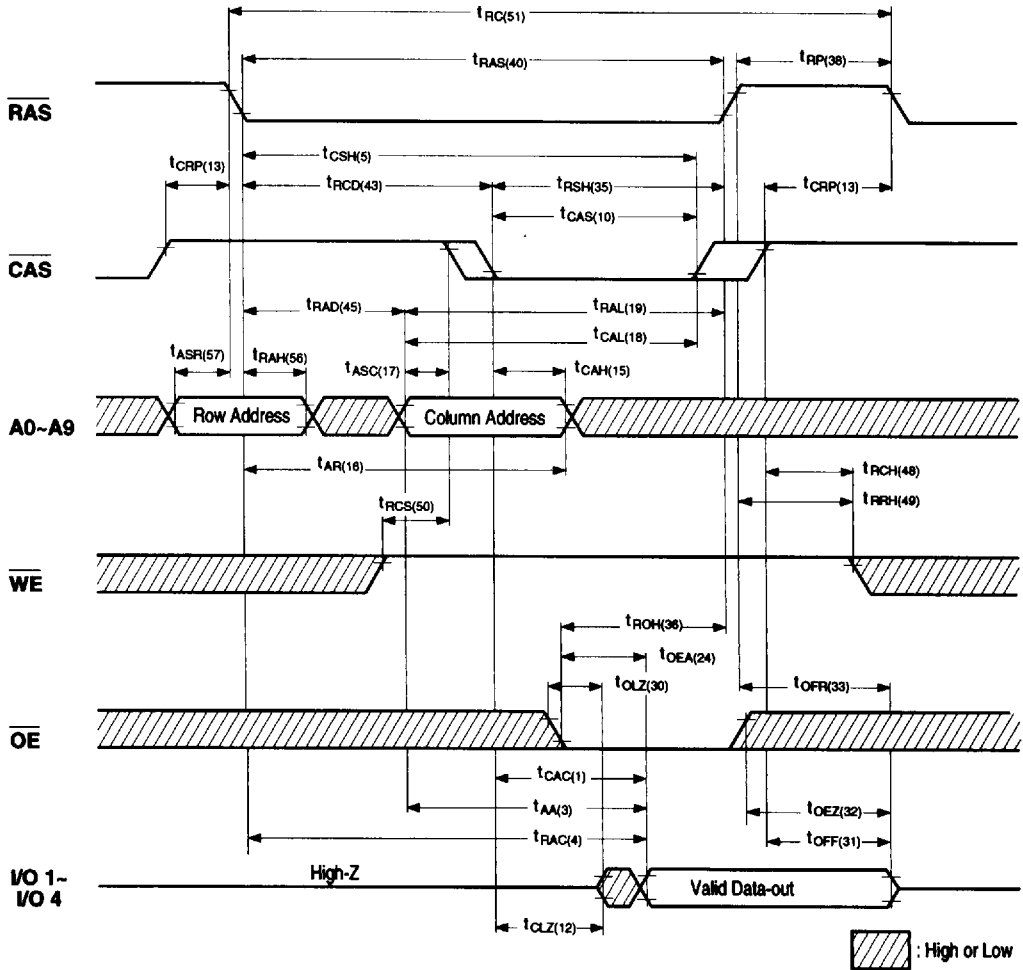

WRITE CYCLE (EARLY WRITE)

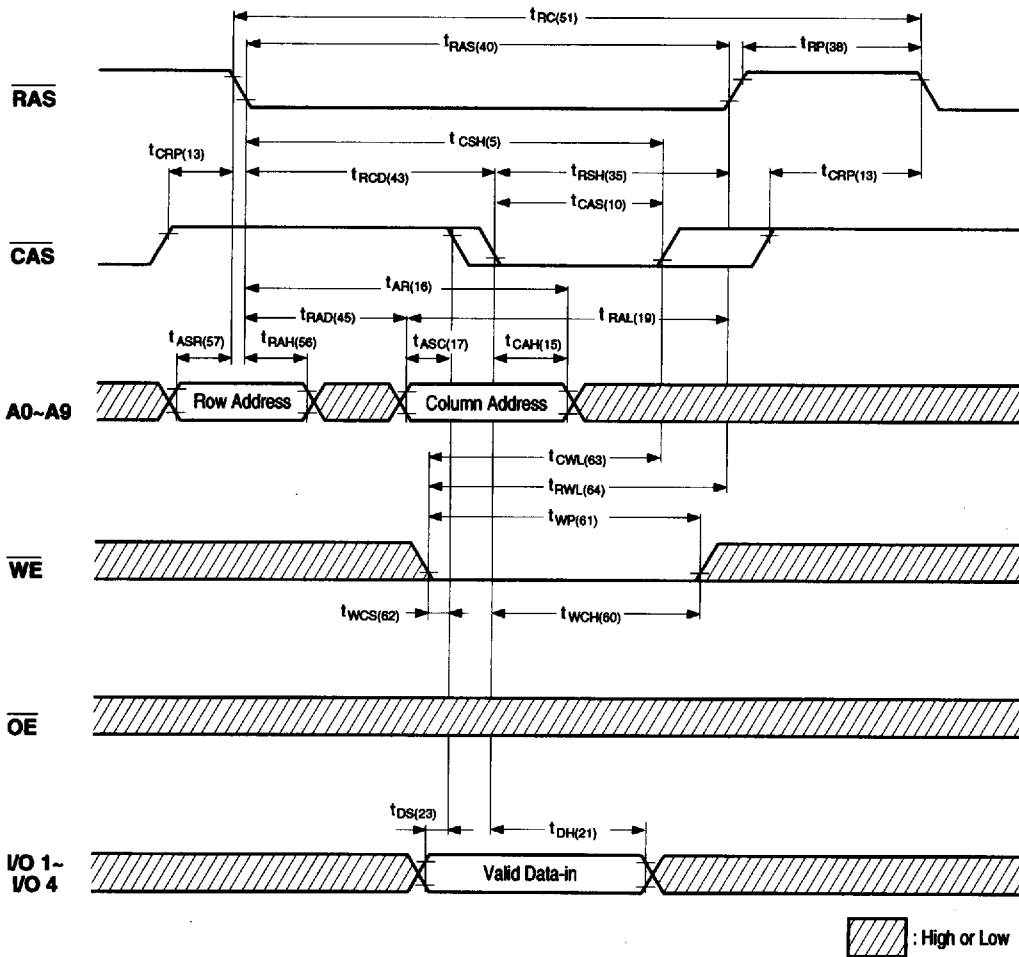

WRITE CYCLE (\overline{OE} -CONTROLLED WRITE)

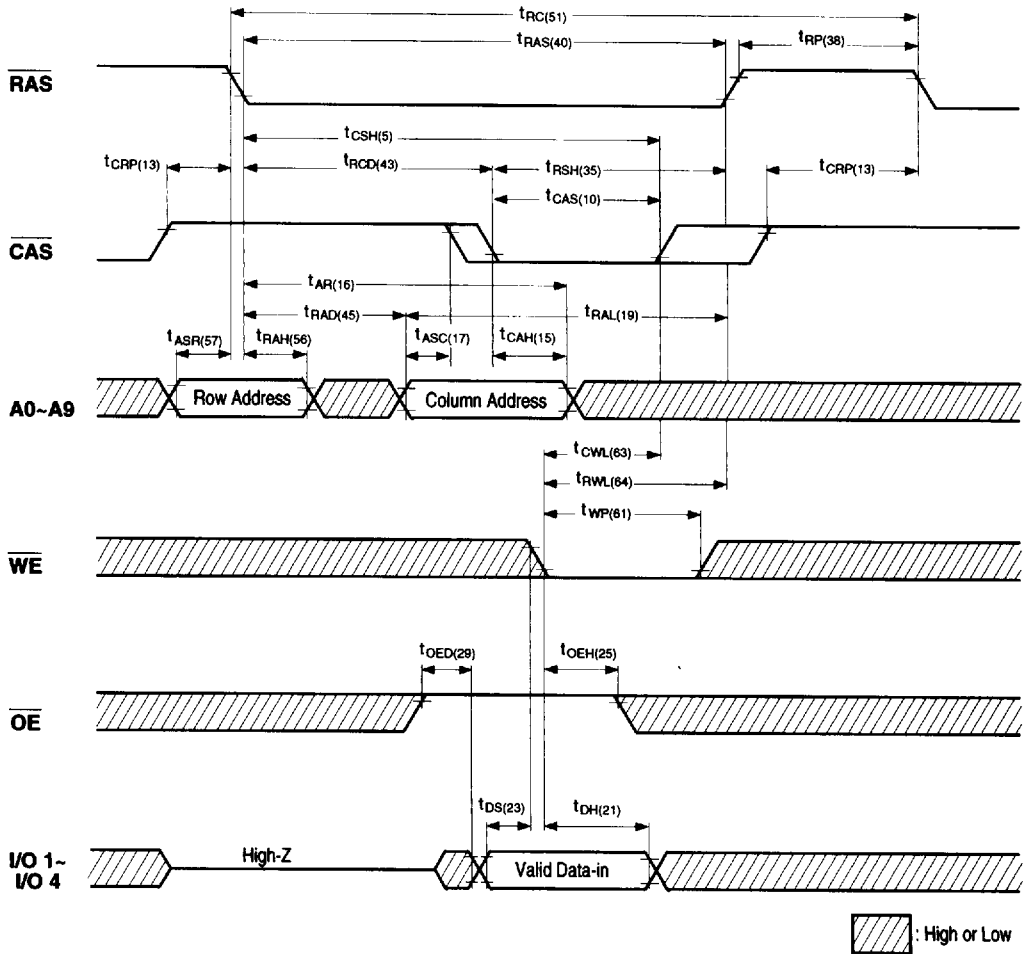

READ-MODIFY-WRITE CYCLE

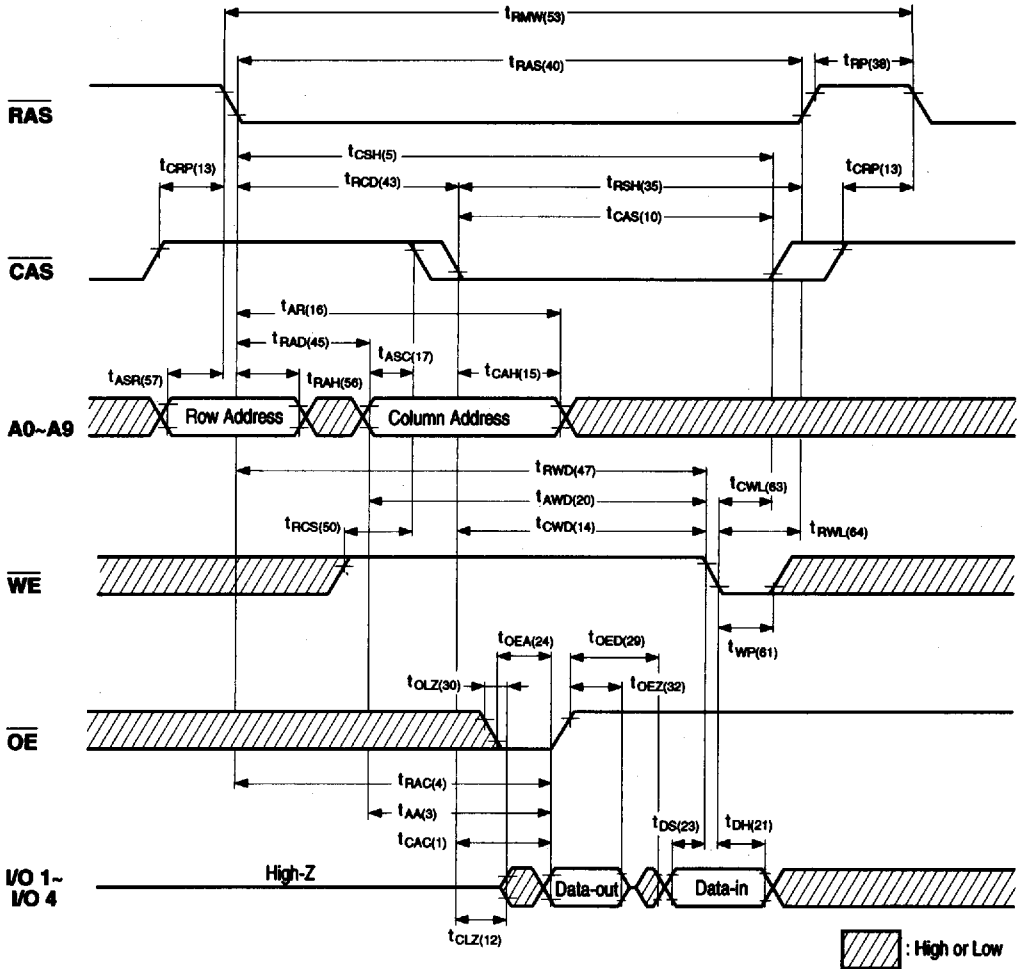

■ 9005650 0001212 205 ■

EDO (HYPER PAGE) MODE READ CYCLE (\overline{OE} AND \overline{WE} CONTROLLED OUTPUT)

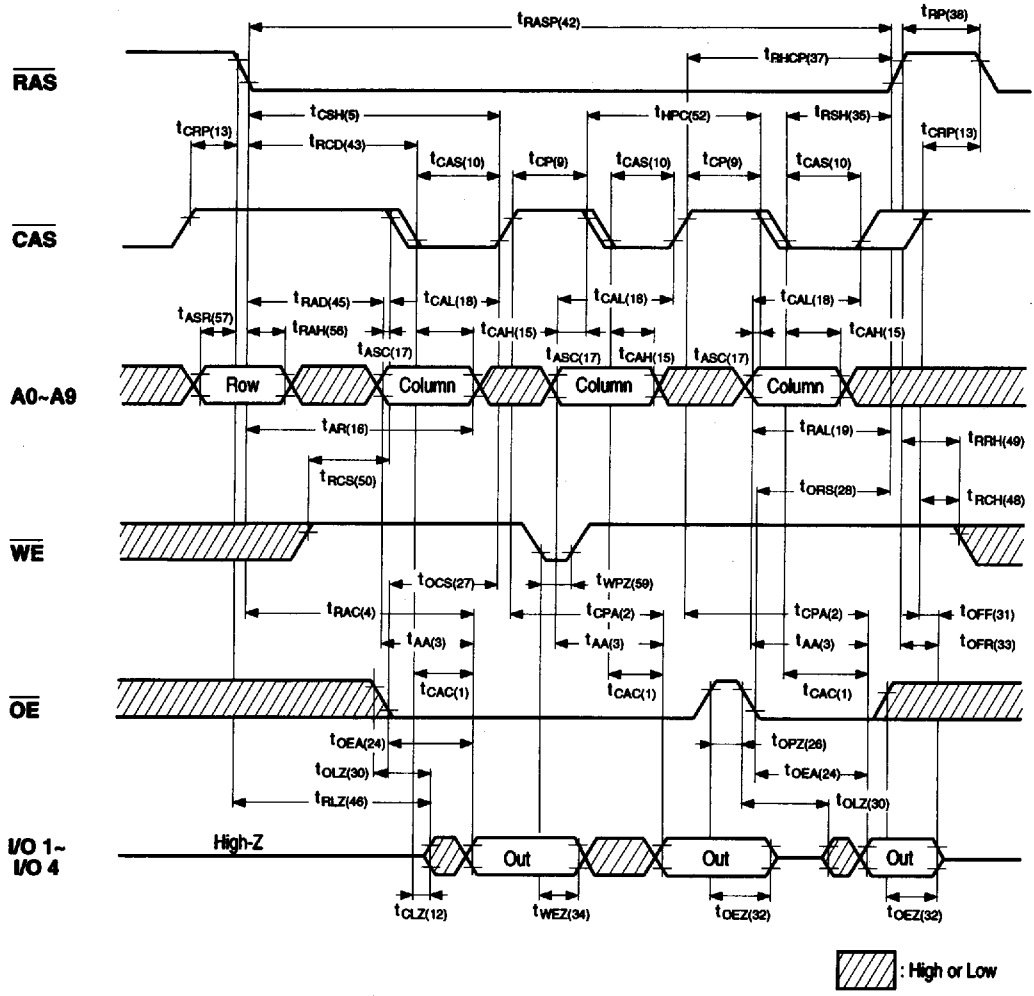

EDO (HYPER PAGE) MODE EARLY WRITE CYCLE

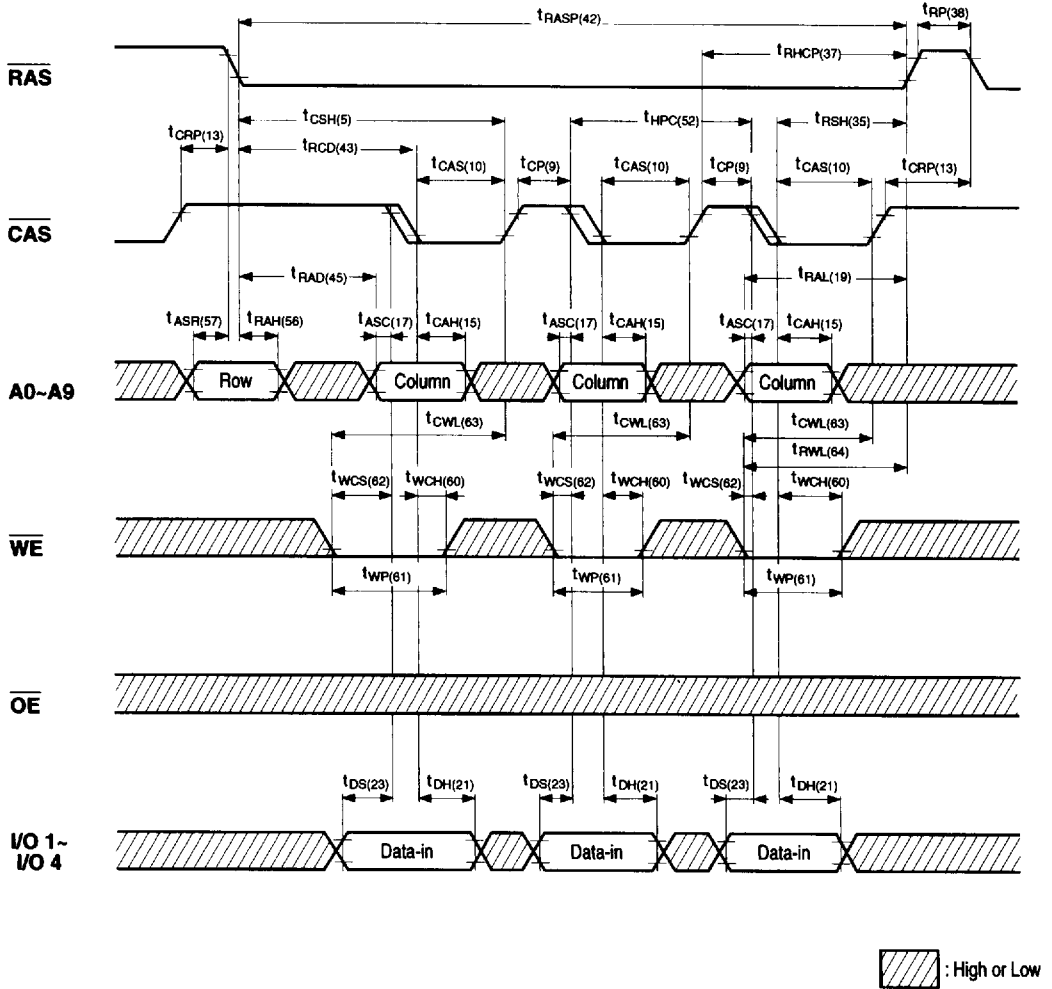

RAS ONLY REFRESH CYCLE

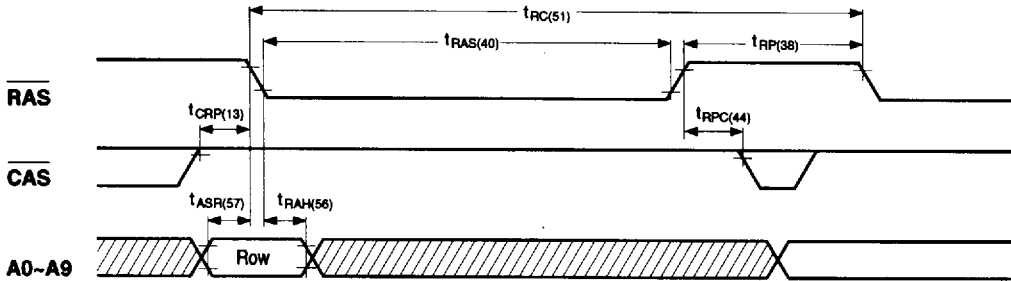

Note: \overline{WE} , \overline{OE} = Don't care.

: High or Low

CAS BEFORE RAS REFRESH CYCLE

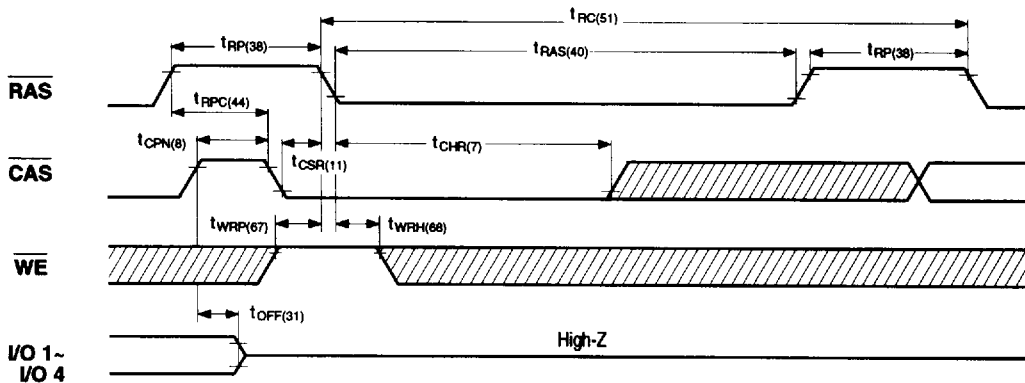

Note: \overline{OE} , A0~A9 = Don't care.

\overline{WE} must be high at the falling edge of \overline{RAS} in order to prevent from entering test mode.

: High or Low

HIDDEN REFRESH CYCLE (READ)

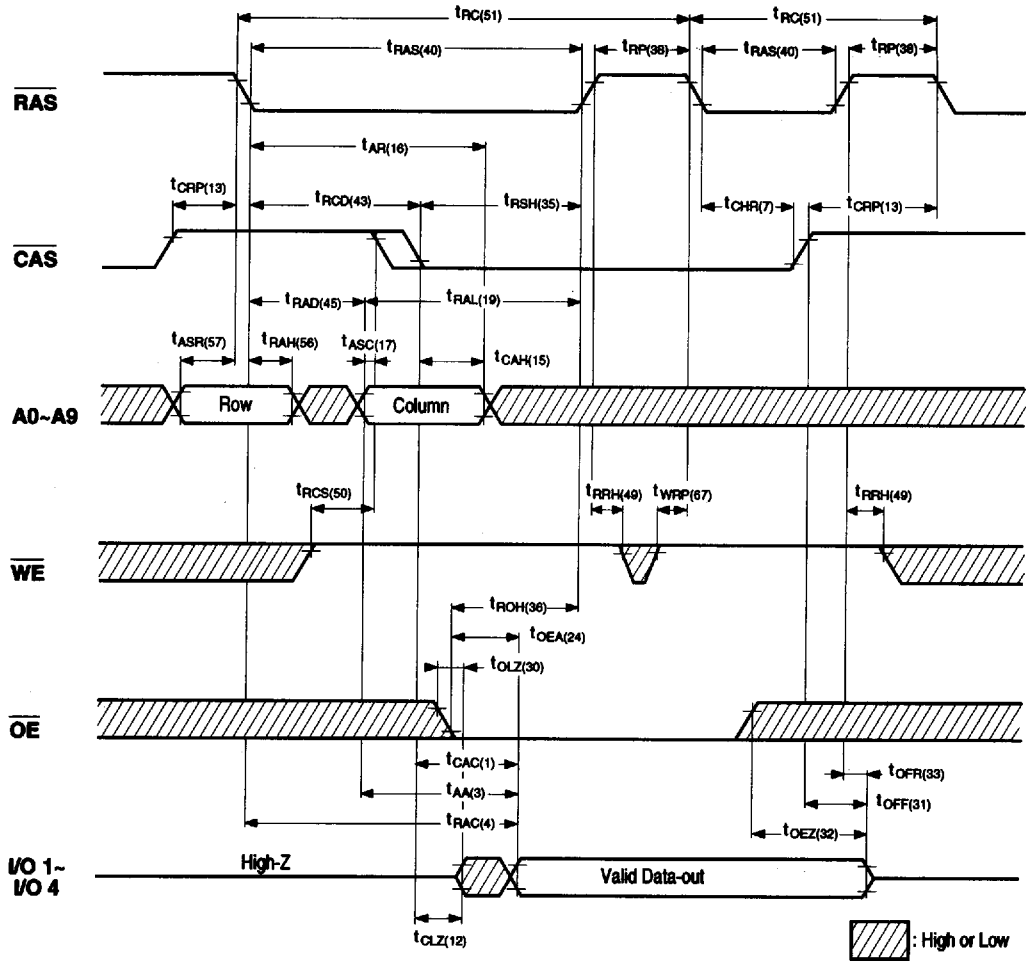

9005650 0001218 723

HIDDEN REFRESH CYCLE (EARLY WRITE)

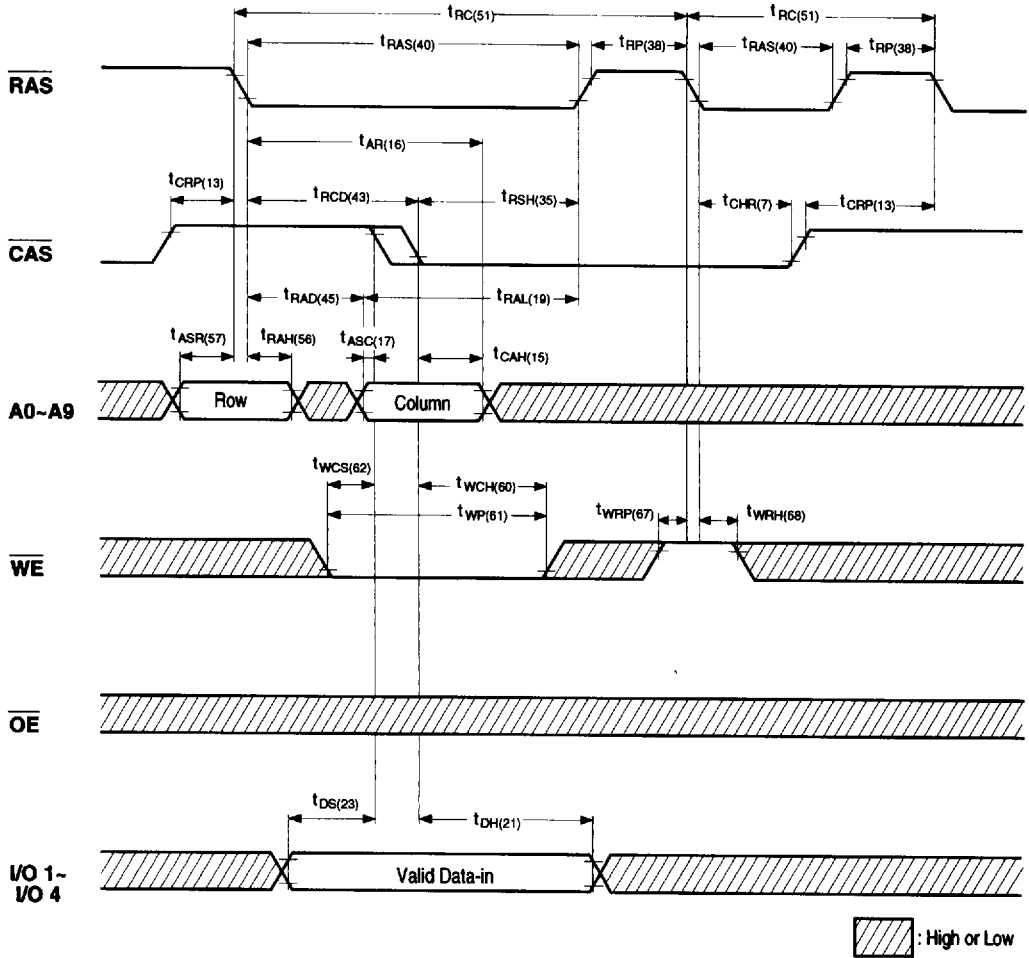

TEST MODE SET CYCLE (\overline{WE} , \overline{CAS} BEFORE \overline{RAS} REFRESH CYCLE)

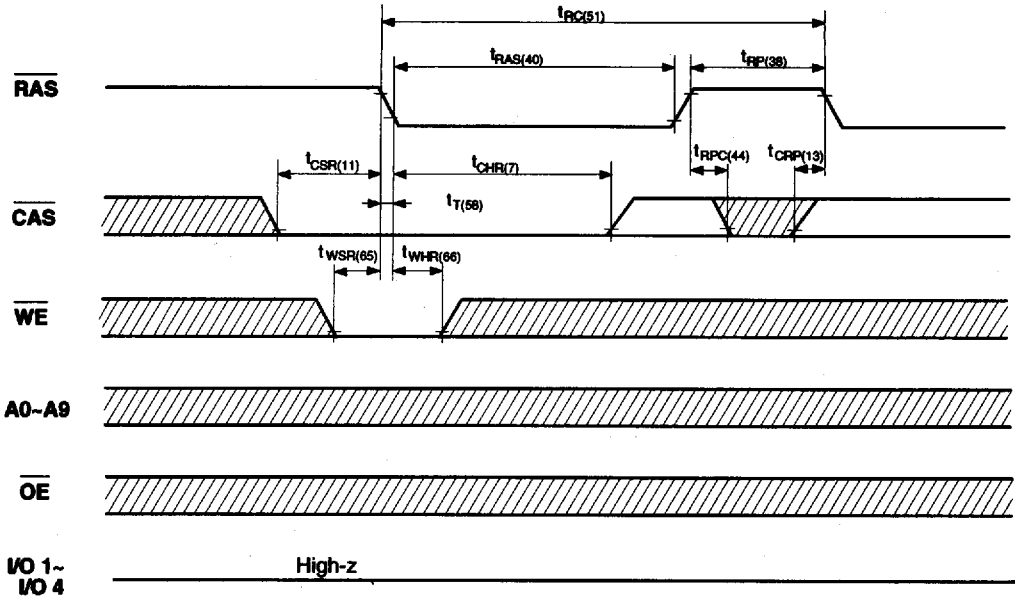

■ The NN514405A/B has an 8 bit parallel Test Mode Function for reducing test time. In the Test Mode, memory configuration is 512K x 8 bits and the Column address A0 is ignored.

a. Entering the test mode:

The NN514405A/B test mode is entered by using the test mode set cycle (\overline{WE} , \overline{CAS} before \overline{RAS} cycle).

b. Read/Write operation in test mode:

For Write cycle, data input from each I/O (I/O1 ~ I/O4) is written to 2 bit memory cells (total 4bits) at the same time. During the read cycle, if the 2 bits of data are equal then a "1" is output from each I/O. If there is a difference in the read data for a given 2 bit pair, a "0" will be output from that I/O.

c. Exiting the test mode:

The NN514405A/B will exit the test mode by either a \overline{RAS} only refresh cycle or a \overline{CAS} before \overline{RAS} refresh cycle with \overline{WE} "high".

d. Refresh during test mode:

During test mode refresh must be executed by a normal Read cycle or a \overline{WE} , \overline{CAS} before \overline{RAS} refresh cycle.

■ 9005650 0001220 381 ■

SELF REFRESH MODE

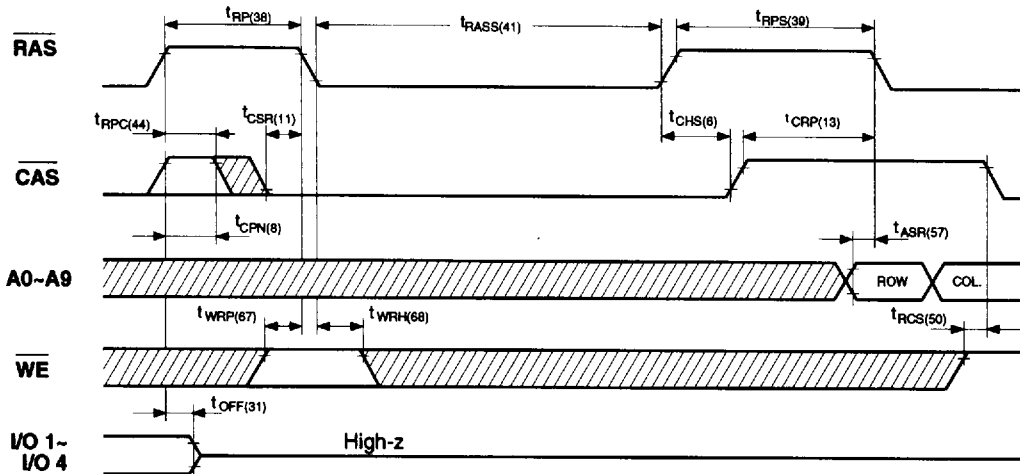

 : High or Low

■ The NN514405A/B L version has a Self Refresh Mode.

a. Entering the Self Refresh Mode:

The NN514405AL/BL Self Refresh Mode is entered by using $\overline{\text{CAS}}$ before $\overline{\text{RAS}}$ cycle with $\overline{\text{WE}}$ " high " and holding $\overline{\text{RAS}}$ and CAS signal " low " longer than 300 μ s.

b. Continuing the Self Refresh Mode:

The Self Refresh Mode is continued by holding $\overline{\text{RAS}}$ " low " after entering the Self Refresh Mode.

It does not depend on CAS being " high " or " low " after entering the Self Refresh Mode for to continue the Self Refresh Mode.

c. Exiting the Self Refresh Mode:

The NN514405AL/BL exits the Self Refresh Mode when the $\overline{\text{RAS}}$ signal is brought " high ".

ORDERING INFORMATION

NN514405XXX(X) - XX

