

54F/74F299 Octal Universal Shift/Storage Register with Common Parallel I/O Pins

General Description

The 'F299 is an 8-bit universal shift/storage register with TRI-STATE® outputs. Four modes of operation are possible: hold (store), shift left, shift right and load data. The parallel load inputs and flip-flop outputs are multiplexed to reduce the total number of package pins. Additional outputs, Q_0 – Q_7 , are provided to allow easy serial cascading. A separate active LOW Master Reset is used to reset the register.

Features

- Common parallel I/O for reduced pin count
- Additional serial inputs and outputs for expansion
- Four operating modes: shift left, shift right, load and store
- TRI-STATE outputs for bus-oriented applications
- Guaranteed 4000V minimum ESD protection

Ordering Code: See Section 11

Commercial	Military	Package Number	Package Description
74F299PC		N20A	20-Lead (0.300" Wide) Molded Dual-In-Line
	54F299DM (Note 2)	J20A	20-Lead Ceramic Dual-In-Line
74F299SC (Note 1)		M20B	20-Lead (0.300" Wide) Molded Small Outline, JEDEC
74F299SJ (Note 1)		M20D	20-Lead (0.300" Wide) Molded Small Outline, EIAJ
	54F299FM (Note 2)	W20A	20-Lead Cerpack
	54F299LM (Note 2)	E20A	20-Lead Ceramic Leadless Chip Carrier, Type C

Note 1: Devices also available in 13" reel. Use suffix = SCX and SJX.

Note 2: Military grade device with environmental and burn-in processing. Use suffix = DMQB, FMQB and LMQB.

Logic Symbols

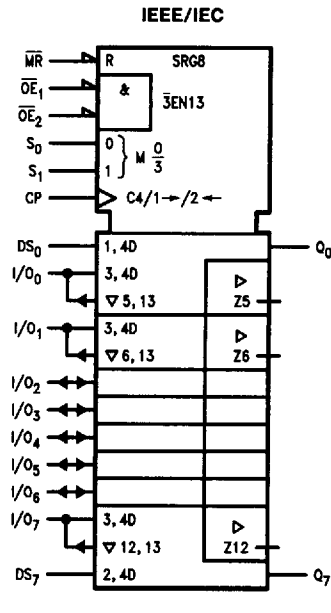
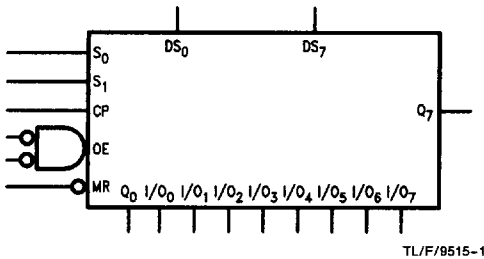

Connection Diagrams

Pin Assignment
for DIP, SOIC and Flatpak

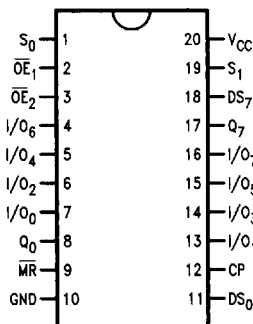

TL/F/9515-2

Pin Assignment
for LCC

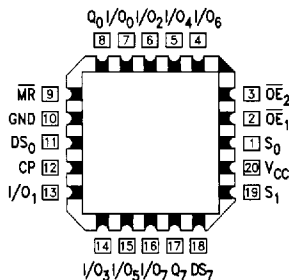

TL/F/9515-3

Unit Loading/Fan Out: See Section 2 for U.L. definitions

Pin Names	Description	54F/74F	
		U.L. HIGH/LOW	Input I_{IH}/I_{IL} Output I_{OH}/I_{OL}
CP	Clock Pulse Input (Active Rising Edge)	1.0/1.0	20 μ A/ -0.6 mA
DS ₀	Serial Data Input for Right Shift	1.0/1.0	20 μ A/ -0.6 mA
DS ₇	Serial Data Input for Left Shift	1.0/1.0	20 μ A/ -0.6 mA
S ₀ , S ₁	Mode Select Inputs	1.0/2.0	20 μ A/ -1.2 mA
MR	Asynchronous Master Reset Input (Active LOW)	1.0/1.0	20 μ A/ -0.6 mA
OE ₁ , OE ₂	TRI-STATE Output Enable Inputs (Active LOW)	1.0/1.0	20 μ A/ -0.6 mA
I/O ₀ -I/O ₇	Parallel Data Inputs or TRI-STATE Parallel Outputs	3.5/1.083	70 μ A/ -0.65 mA
Q ₀ , Q ₇	Serial Outputs	150/40(33.3)	-3 mA/24 mA (20 mA)
		50/33.3	-1 mA/20 mA

Functional Description

The 'F299 contains eight edge-triggered D-type flip-flops and the interstage logic necessary to perform synchronous shift left, shift right, parallel load and hold operations. The type of operation is determined by S₀ and S₁, as shown in the Mode Select Table. All flip-flop outputs are brought out through TRI-STATE buffers to separate I/O pins that also serve as data inputs in the parallel load mode. Q₀ and Q₇ are also brought out on other pins for expansion in serial shifting of longer words.

A LOW signal on MR overrides the Select and CP inputs and resets the flip-flops. All other state changes are initiated by the rising edge of the clock. Inputs can change when the clock is in either state provided only that the recommended setup and hold times, relative to the rising edge of CP, are observed.

A HIGH signal on either OE₁ or OE₂ disables the TRI-STATE buffers and puts the I/O pins in the high impedance state. In this condition the shift, hold, load and reset operations can still occur. The TRI-STATE outputs are also disabled by HIGH signals on both S₀ and S₁ in preparation for a parallel load operation.

Mode Select Table

Inputs				Response
MR	S ₁	S ₀	CP	
L	X	X	X	Asynchronous Reset; Q ₀ -Q ₇ = LOW
H	H	H	↗	Parallel Load; I/O _n → Q _n
H	L	H	↗	Shift Right; DS ₀ → Q ₀ , Q ₀ → Q ₁ , etc.
H	H	L	↗	Shift Left; DS ₇ → Q ₇ , Q ₇ → Q ₆ , etc.
H	L	L	X	Hold

H = HIGH Voltage Level

L = LOW Voltage Level

X = Immaterial

↗ = LOW-to-HIGH Clock Transition

Logic Diagram

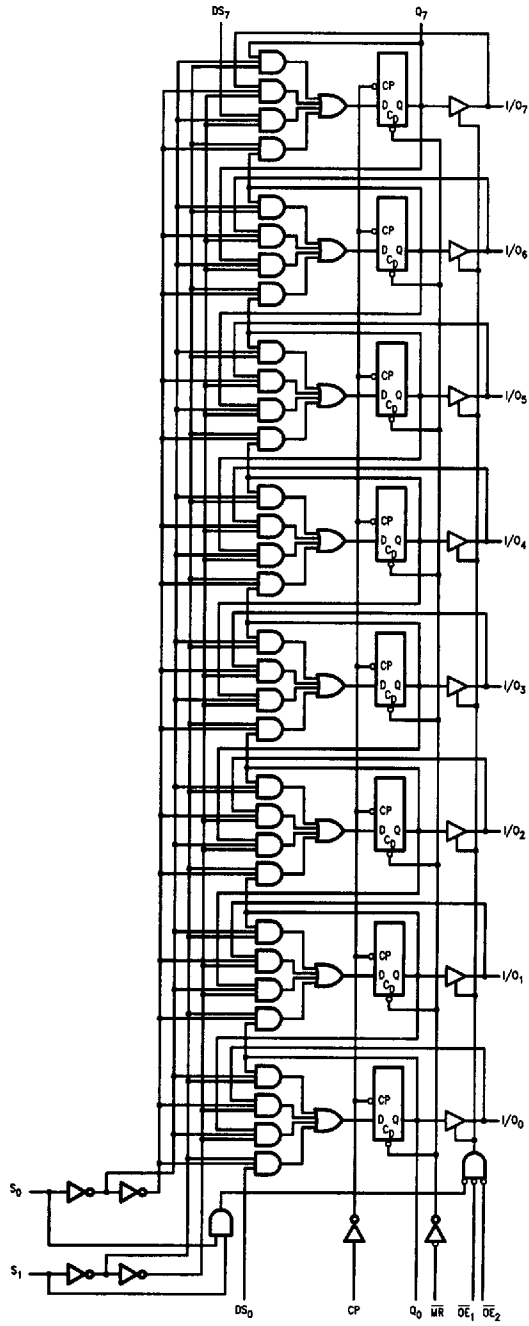

TL/F/9515-5

Please note that this diagram is provided only for the understanding of logic operations and should not be used to estimate propagation delays.

Absolute Maximum Ratings (Note 1)

If Military/Aerospace specified devices are required, please contact the National Semiconductor Sales Office/Distributors for availability and specifications.

Storage Temperature	-65°C to +150°C
Ambient Temperature under Bias	-55°C to +125°C
Junction Temperature under Bias	-55°C to +175°C
Plastic	-55°C to +150°C
V _{CC} Pin Potential to Ground Pin	-0.5V to +7.0V
Input Voltage (Note 2)	-0.5V to +7.0V
Input Current (Note 2)	-30 mA to +5.0 mA
ESD Last Passing Voltage (Min)	4000V

Note 1: Absolute maximum ratings are values beyond which the device may be damaged or have its useful life impaired. Functional operation under these conditions is not implied.

Note 2: Either voltage limit or current limit is sufficient to protect inputs.

Voltage Applied to Output in HIGH State (with V _{CC} = 0V)	-0.5V to V _{CC}
Standard Output	-0.5V to +5.5V
TRI-STATE Output	-0.5V to +5.5V
Current Applied to Output in LOW State (Max)	twice the rated I _{OL} (mA)

Recommended Operating Conditions

Free Air Ambient Temperature	-55°C to +125°C
Military	0°C to +70°C
Commercial	
Supply Voltage	
Military	+4.5V to +5.5V
Commercial	+4.5V to +5.5V

DC Electrical Characteristics

Symbol	Parameter	54F/74F			Units	V _{CC}	Conditions
		Min	Typ	Max			
V _{IH}	Input HIGH Voltage	2.0			V		Recognized as a HIGH Signal
V _{IL}	Input LOW Voltage	0.8			V		Recognized as a LOW Signal
V _{CD}	Input Clamp Diode Voltage	-1.2			V	Min	I _{IN} = -18 mA
V _{OH}	Output HIGH Voltage	54F 10% V _{CC}	2.5		V	Min	I _{OH} = -1 mA (Q ₀ , Q ₇ , I/O _n)
		54F 10% V _{CC}	2.4				I _{OH} = -3 mA (I/O _n)
		74F 10% V _{CC}	2.5				I _{OH} = -1 mA (Q ₀ , Q ₇ , I/O _n)
		74F 10% V _{CC}	2.4				I _{OH} = -3 mA (I/O _n)
		74F 5% V _{CC}	2.7				I _{OH} = -1 mA (Q ₀ , Q ₇ , I/O _n)
		74F 5% V _{CC}	2.7				I _{OH} = -3 mA (I/O _n)
V _{OL}	Output LOW Voltage	54 10% V _{CC}	0.5		V	Min	I _{OL} = 20 mA
		74 10% V _{CC}	0.5				I _{OL} = 20 mA (Q ₀ , Q ₇)
		74 10% V _{CC}	0.5				I _{OL} = 24 mA (I/O _n)
I _{IH}	Input HIGH Current	54F	20.0		μA	Max	V _{IN} = 2.7V (CP, DS ₀ , DS ₇ , S ₀ , S ₁ , MR, OE ₁ , OE ₂)
		74F	5.0				
I _{BVI}	Input HIGH Current Breakdown Test	54F	100		μA	Max	V _{IN} = 7.0V (CP, DS ₀ , DS ₇ , S ₀ , S ₁ , MR, OE ₁ , OE ₂)
		74F	7.0				
I _{BVIT}	Input HIGH Current Breakdown Test (I/O)	54F	1.0		mA	Max	V _{IN} = 5.5V (I/O _n)
		74F	0.5				
I _{CEX}	Output HIGH Leakage Current	54F	250		μA	Max	V _{OUT} = V _{CC}
		74F	50				
V _{ID}	Input Leakage Test	74F	4.75		V	0.0	I _{ID} = 1.9 μA All Other Pins Grounded
I _{OD}	Output Leakage Circuit Current	74F	3.75		μA	0.0	V _{IOD} = 150 mV All Other Pins Grounded
I _{IL}	Input LOW Current		-0.6		mA	Max	V _{IN} = 0.5V (CP, DS ₀ , DS ₇ , MR, OE ₁ , OE ₂)
			-1.2				V _{IN} = 0.5V (S ₀ , S ₁)
I _{IH} + I _{OZH}	Output Leakage Current		70		μA	Max	V _{I/O} = 2.7V (I/O _n)
I _{IL} + I _{OZL}	Output Leakage Current		-650		μA	Max	V _{I/O} = 0.5V (I/O _n)
I _{OS}	Output Short-Circuit Current		-60	-150	mA	Max	V _{OUT} = 0V
I _{ZZ}	Bus Drainage Test		500		μA	0.0V	V _{OUT} = 5.25V
I _{CCH}	Power Supply Current		68	95	mA	Max	V _O = HIGH
I _{CCL}	Power Supply Current		68	95	mA	Max	V _O = LOW
I _{CCZ}	Power Supply Current		68	95	mA	Max	V _O = HIGH Z

AC Electrical Characteristics: See Section 2 for Waveforms and Load Configurations

Symbol	Parameter	74F			54F		74F		Units	Fig. No.
		T _A = +25°C V _{CC} = +5.0V C _L = 50 pF			T _A , V _{CC} = Mil C _L = 50 pF		T _A , V _{CC} = Com C _L = 50 pF			
		Min	Typ	Max	Min	Max	Min	Max		
f _{max}	Maximum Input Frequency	70	100		85		70		MHz	2-1
t _{PLH} t _{PHL}	Propagation Delay CP to Q ₀ or Q ₇	4.0	7.0	8.0	4.0	9.0	4.0	8.5	ns	2-3
t _{PLH} t _{PHL}	Propagation Delay CP to I/O _n	3.5	7.0	9.0	3.5	10.0	3.5	10.0		
t _{PHL}	Propagation Delay MR to Q ₀ or Q ₇	5.5	7.5	9.5	5.5	12.5	5.5	10.5	ns	2-3
t _{PHL}	Propagation Delay MR to I/O _n	5.5	11.0	10.0	5.5	12.0	5.5	10.5		
t _{pZH} t _{pZL}	Output Enable Time OE to I/O _n	3.5	6.0	8.0	3.0	9.5	3.5	9.0	ns	2-5
t _{PHZ} t _{PLZ}	Output Disable Time OE to I/O _n	2.0	4.5	6.0	1.5	7.0	2.0	7.0		
t _{pZH} t _{pZL}	Output Enable Time S _n to I/O _n	3.5		9.0	3.0	10.5	3.5	10.0	ns	2-5
t _{PHZ} t _{PLZ}	Output Disable Time S _n to I/O _n	2.5		6.0	1.5	7.0	2.5	7.0		
t _{PHZ} t _{PLZ}	Output Disable Time S _n to I/O _n	1.5		5.5	1.0	6.5	1.5	6.5	ns	2-5

AC Operating Requirements: See Section 2 for Waveforms

Symbol	Parameter	74F		54F		74F		Units	Fig. No.
		T _A = +25°C V _{CC} = +5.0V		T _A , V _{CC} = Mil		T _A , V _{CC} = Com			
		Min	Max	Min	Max	Min	Max		
t _s (H) t _s (L)	Setup Time, HIGH or LOW S ₀ or S ₁ to CP	8.5		10.0		8.5		ns	2-6
t _h (H) t _h (L)	Hold Time, HIGH or LOW S ₀ or S ₁ to CP	0		0		0			
t _s (H) t _s (L)	Setup Time, HIGH or LOW I/O _n , DS ₀ or DS ₇ to CP	5.0		5.0		5.0		ns	2-6
t _h (H) t _h (L)	Hold Time, HIGH or LOW I/O _n , DS ₀ or DS ₇ to CP	2.0		2.0		2.0			
t _w (H) t _w (L)	CP Pulse Width HIGH or LOW	5.0		5.0		5.0		ns	2-4
t _w (L)	MR Pulse Width, LOW	5.0		6.0		5.0		ns	2-4
t _{rec}	Recovery Time, MR to CP	7.0		12.0		7.0		ns	2-6