

HFE4073

HONEYWELL INC/ MICRO

High Power Fiber Optic LED, Plastic Package

FEATURES

- High power LED provides 10 μ W into 50/125 micron fiber
- High speed up to 150 MHz typical
- Optimized for 50 mA operation
- Plastic cap TO-18 type package
- Available in SMA and ST[®] style receptacles
- Designed to operate with Honeywell fiber optic receivers
- Metal package also available (HFE4053)

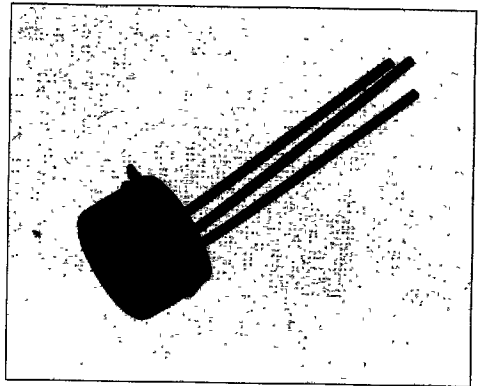

DESCRIPTION

The HFE4073 is a high radiance AlGaAs 850 nanometer LED optimized for coupling into small fiber core diameters at a forward current of 50 mA. The "Caprock"™ LED chip combines high power coupling with wide bandwidth. The peak wavelength is matched for use with Honeywell silicon fiber optic detectors and receivers.

OUTLINE DIMENSIONS in inches (mm)

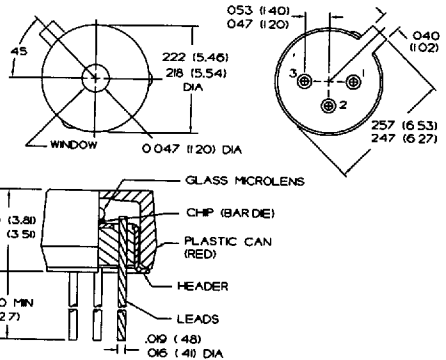

APPLICATION

The HFE4073 is a high radiance LED packaged on a TO-18 header with a plastic cap. Data rates can vary from DC to above 150 MHz depending upon component application. The LED converts electrical current into optical power that can be used in fiber optic communications. As the current varies (typically from 10 to 100 mA), the light intensity increases proportionally. When high currents (near the 100 mA range) flow through the HFE4073 continually, heat sinking is recommended to maintain the expected long life. If the HFE4073 is heat sunk, the package has a typical thermal resistance of 250°C per watt. If not heat sunk, typical thermal resistance is 500°C per watt.

The HFE4073 LED sends high optical power into standard fiber optic cables. A 0.25 mm diameter glass microlens over the "Caprock" junction collimates the light, increasing the intensity, which directs greater power into standard fiber optic cables.

Pinout

1. Anode
2. Cathode
3. Not connected

Notes

1. ST is a registered trademark of AT & T.

All Performance Curves Show Typical Values



Honeywell

Honeywell Optoelectronics reserves the right to make changes at any time in order to improve design and supply the best products possible

HFE4073

HONEYWELL INC/ MICRO

High Power Fiber Optic LED, Plastic Package

ELECTRO-OPTICAL CHARACTERISTICS (T_C = 25°C unless otherwise noted)

PARAMETER	SYMBOL	MIN	TYP	MAX	UNITS	TEST CONDITIONS
Fiber Coupled Power ⁽¹⁾	P _{OC}					I _F = 50 mA, 50/125 micron, ⁽²⁾ 0.20 NA fiber ⁽³⁾
HFE4073-0X2		3	10		μW	
		-25.2	-20.0		dBm	
HFE4073-0X3		10	20		μW	
		-20.0	-17.0		dBm	
Forward Voltage	V _F		1.60	1.90	V	I _F = 50 mA
Reverse Voltage	BVR	1.0	5.0		V	I _R = 10 μA
Peak Wavelength	λ _P		850		nm	I _F = 50 mA DC
Spectral Bandwidth	Δλ		45		nm	I _F = 50 mA DC
Response Time					ns	1 V Prebias, 100 mA peak ⁽³⁾
-02X, 10-90%	t _r		4	6		
-02X, 90-10%	t _f		4	6		
-03X, 10-90%	t _r		2.5	3.5		
-03X, 90-10%	t _f		2.5	3.5		
Analog bandwidth	BWE					I _F = 100 mA DC, sinusoidal modulation ⁽³⁾
-02X			100		MHz	
-03X			150		MHz	
P _O Temperature Coefficient	ΔP _O /ΔT		-0.02		dB/°C	I _F = 50 mA
Series Resistance	r _S		4.0		Ω	DC
Capacitance	C		70		pF	V _R = 0 V, f = 1 MHz

Notes

- Dash numbers indicate power output. See ORDER GUIDE
- HFE4073 is tested using a 50/125 μm fiber located in a special fixture. The fiber is mechanically centered with respect to the outside can diameter. Actual coupled power values may vary due to alignment procedures and/or receptacle and fiber tolerances.
- HFE4073 must be heat sunk for continuous I_F > 50 mA operation (i.e. mounted in a metal connector with thermally conductive epoxy).

ABSOLUTE MAXIMUM RATINGS

(25°C Free-Air Temperature unless otherwise noted)

Storage temperature	-40 to +100°C
Case operating temperature	-40 to +100°C
Lead solder temperature	260°C, 10 s
Continuous forward current	50 mA
Continuous forward current (heat sink)	100 mA
Reverse voltage	1 V @ 10 μA

Notes

Stresses greater than those listed under "Absolute Maximum Ratings" may cause permanent damage to the device. This is a stress rating only and functional operation of the device at these or any other conditions above those indicated in the operational section of this specification is not implied. Exposure to absolute maximum rating conditions for extended periods of time may affect reliability.

FIBER INTERFACE

Honeywell LEDs interface with multimode fibers from 50/125 to 200/230 microns, and single mode 8/125 micron fiber optic cables. Final tests use 50/125 micron core fiber. All multimode fiber optic cables between 50/125 and 200/230 should operate with similar excellent performance. See table for typical powers.

TYPICAL COUPLED POWER (μW/dBm) @ I_F = 50 mA

Dia.	Index	N.A.	-022/-032	-023/-033
8/125	Step		0.17/-37.5	0.6/-32.0
50/125	Graded	0.20	10/-20.0	20/-17.0
62.5/125	Graded	0.28	15/-18.2	45/-13.5
100/140	Graded	0.29	40/-13.9	115/-9.4

HFE4073

HONEYWELL INC/ MICRO

High Power Fiber Optic LED, Plastic Package

ORDER GUIDE

Description	Catalog Listing
Standard screening, plastic package, typical power out 10 μ W	HFE4073-022
Standard screening, plastic package, typical power out 20 μ W	HFE4073-023
Standard screening, plastic package, typical power out 10 μ W	HFE4073-032
Standard screening, plastic package, typical power out 20 μ W	HFE4073-033

This product is also available in special interface receptacles for interfacing to standard fiber optic cables.

Fig. 1 Typical Optical Power Output vs Forward Current

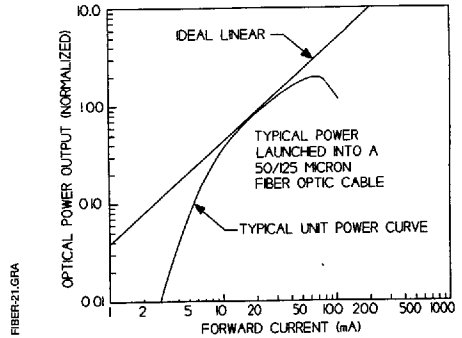

Fig. 2 Typical Spectral Output vs Wavelength

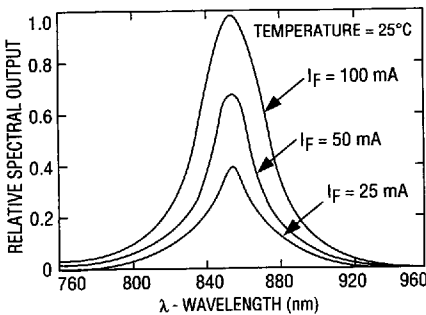

Fig. 3 Typical Optical Power Output vs Case Temperature

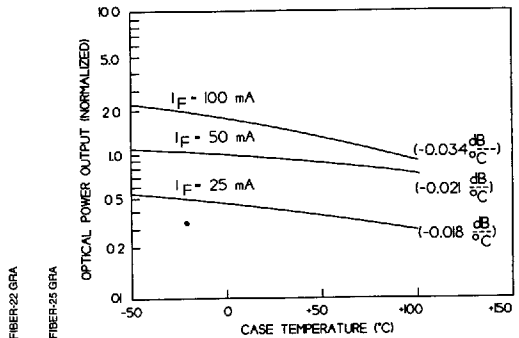

Fig. 4 Typical Relative Power Output vs Frequency

