

M-8870 DTMF Receiver

The Teltone® M-8870 is a full DTMF Receiver that integrates both bandsplit filter and decoder functions into a single 18-pin DIP or SOIC package. Manufactured using CMOS process technology, the M-8870 offers low power consumption (35 mW max) and precise data handling. Its filter section uses switched capacitor technology for both the high and low group filters and for dial tone rejection. Its decoder uses digital counting techniques to detect and decode all 16 DTMF tone pairs into a 4-bit code. External component count is minimized by provision of an on-chip differential input amplifier, clock generator, and latched tri-state interface bus. Minimal external components required include a low-cost 3.579545 MHz color burst crystal, a timing resistor, and a timing capacitor.

The M-8870-02 and M-8870-03 provide a "power-down" option which, when enabled, drops consumption to less than 0.5 mW. The -02 and -03 versions can also inhibit the decoding of fourth column digits. The -03 version features increased input sensitivity (see Table 6).

Features

- Low power consumption
- Adjustable acquisition and release times
- Central office quality and performance

- Power-down and inhibit modes (-02 and -03 versions)
- Inexpensive 3.58 MHz time base
- Single 5 volt power supply
- Dial tone suppression

Applications

- Telephone switch equipment
- Mobile radio
- Remote control
- Remote data entry
- Paging Systems
- Personal Computers
- Telephone Answering Machines
- Credit Card Systems

Functional Description

M-8870 operating functions (see Figure 1) include a bandsplit filter that separates the high and low tones of the received pair, and a digital decoder that verifies both the frequency and duration of the received tones before passing the resulting 4-bit code to the output bus.

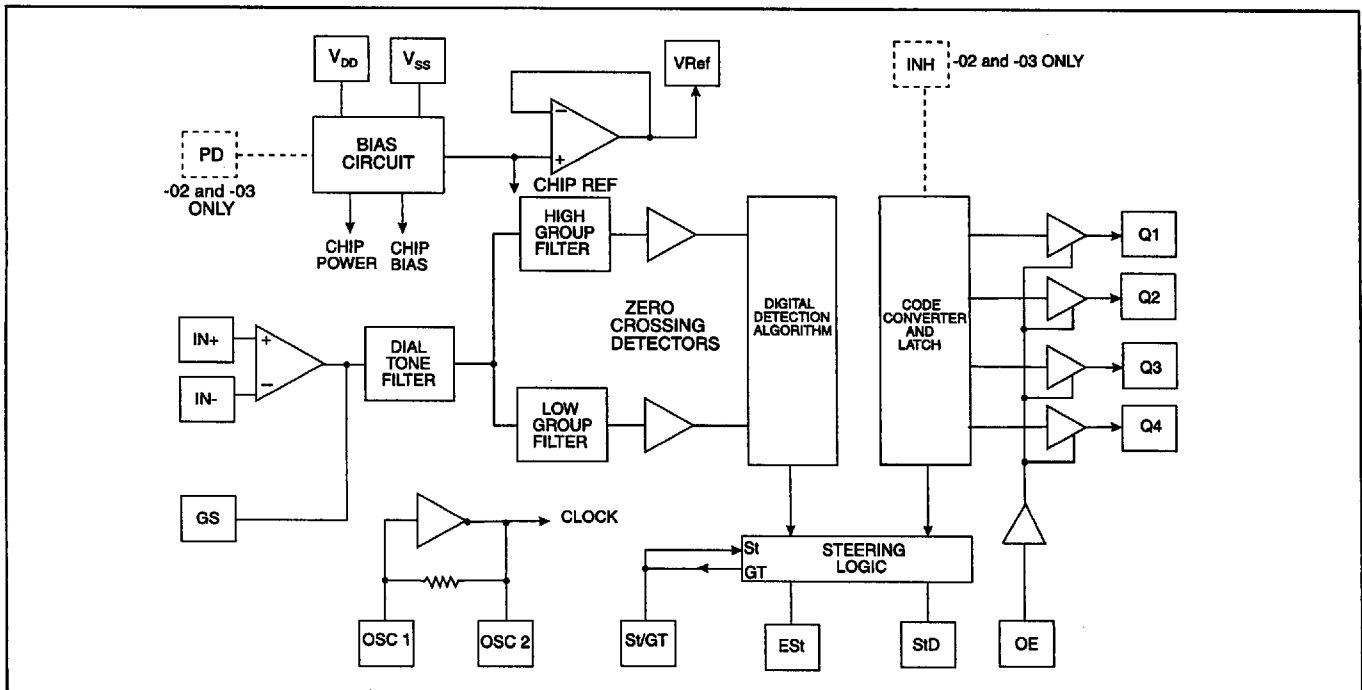

Figure 1 Block Diagram

Filter

The low and high group tones are separated by applying the dual-tone signal to the inputs of two 6th order switched capacitor bandpass filters with bandwidths that correspond to the bands enclosing the low and high group tones. The filter also incorporates notches at 350 and 440 Hz, providing excellent dial tone rejection. Each filter output is followed by a single-order switched capacitor section that smoothes the signals prior to limiting. Signal limiting is performed by high-gain comparators provided with hysteresis to prevent detection of unwanted low-level signals and noise. The comparator outputs provide full-rail logic swings at the frequencies of the incoming tones.

Decoder

The M-8870 decoder uses a digital counting technique to determine the frequencies of the limited tones and to verify that they correspond to standard DTMF frequencies. A complex averaging algorithm is used to protect against tone simulation by extraneous signals (such as voice) while tolerating small frequency variations. The algorithm ensures an optimum combination of immunity to talkoff and tolerance to interfering signals (third tones) and noise. When the detector recognizes the simultaneous presence of two valid tones (known as "signal condition"), it raises the Early Steering flag (EST). Any subsequent loss of signal condition will cause EST to fall.

Steering Circuit

Before a decoded tone pair is registered, the receiver checks for a valid signal duration (referred to as "character-recognition-condition"). This check is performed by an external RC time constant driven by EST. A logic high on EST causes VC (see Figure 2) to rise as the capacitor discharges. Provided that signal condition is maintained (EST remains high) for the validation period (tGTP), VC reaches the threshold (VTS) of the steering logic to register the tone pair, thus latching its corresponding 4-bit code (see Table 5) into the output latch. At this point, the GT output is activated and drives VC to VDD. GT continues to drive high as long as EST remains high.

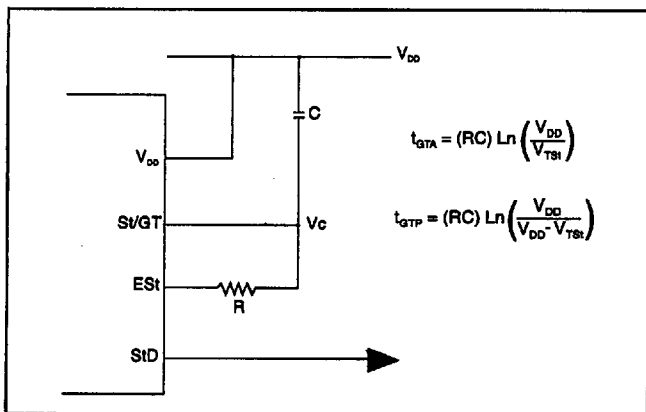

Figure 2 Basic Steering Circuit

Finally, after a short delay to allow the output latch to settle, the "delayed steering" output flag (StD) goes high, signaling that a received tone pair has been registered. The contents of the output latch are made available on the 4-bit output bus by raising the three-state control input (OE) to a logic high. The steering circuit works in reverse to validate the interdigit pause between signals. Thus, as well as rejecting signals too short to be considered valid, the receiver will tolerate signal interruptions (dropouts) too short to be considered a valid pause. This capability, together with the ability to select the steering time constants externally, allows the designer to tailor performance to meet a wide variety of system requirements.

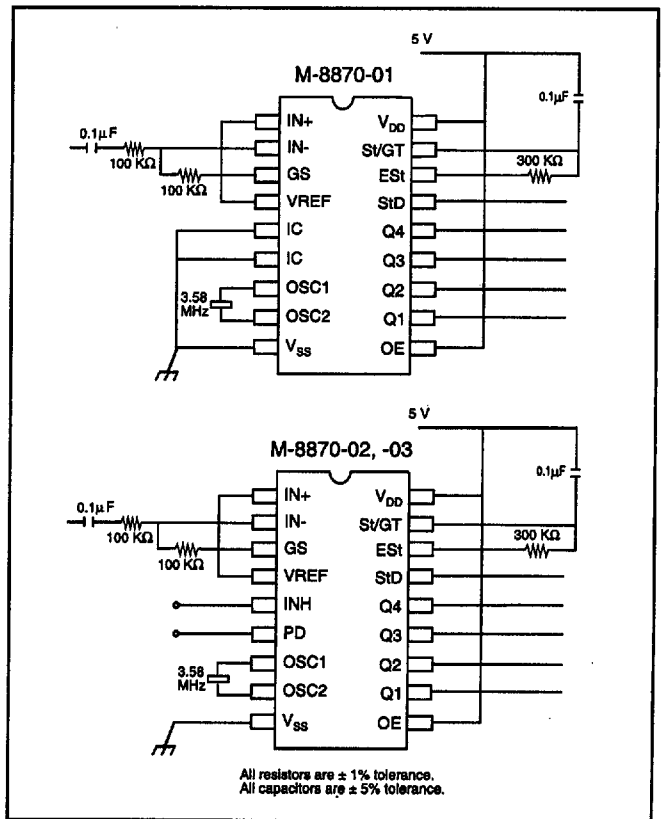

Figure 3 Single-Ended Input Configuration

Guard Time Adjustment

Where independent selection of signal duration and interdigit pause are not required, the simple steering circuit of Figure 4 is applicable. Component values are chosen according to the formula:

$$t_{REC} = t_{DP} + t_{GTP}$$

$$t_{GTP} \cong 0.67 RC$$

The value of t_{DP} is a parameter of the device and t_{REC} is the minimum signal duration to be recognized by the receiver. A value for C of 0.1 µF is recommended for most applications, leaving R to be selected by the designer. For example, a suitable value of R for a t_{REC} of 40 ms would be 300 K ohm. A typical circuit using this steering configuration is shown in

Table 1 Pin Functions

PIN	NAME	DESCRIPTION	
1	IN+	Non-inverting input	Connections to the front-end differential amplifier
2	IN-	Inverting input	
3	GS	Gain select. Gives access to output of front-end amplifier for connection of feedback resistor.	
4	V _{REF}	Reference voltage output (nominally V _{DD} /2). May be used to bias the inputs at mid-rail.	
5	INH*	Inhibits detection of tones representing keys A, B, C, and D.	
6	PD*	Power down. Logic high powers down the device and inhibits the oscillator. Internal pulldown.	
7	OSC1	Clock input	3.579545 MHz crystal connected between these pins completes the internal oscillator.
8	OSC2	Clock output	
9	V _{SS}	Negative power supply (normally connected to 0 V).	
10	OE	Three-state output enable (input). Logic high enables the outputs Q1 - Q4. Internal pullup.	
11 - 14	Q1, Q2, Q3, Q4	Three-state data outputs. When enabled by OE, provides the code corresponding to the last valid tone pair received (see Table 5).	
15	StD	Delayed steering output. Presents a logic high when a received tone pair has been registered and the output latch is updated. Returns to logic low when the voltage on St/GT falls below V _{TSt} .	
16	ES _t	Early steering output. Presents a logic high immediately when the digital algorithm detects a recognizable tone pair (signal condition). Any momentary loss of signal condition will cause ES _t to return to a logic low.	
17	St/GT	Steering input/guard time output (bidirectional). A voltage greater than V _{TSt} detected at St causes the device to register the detected tone pair and update the output latch. A voltage less than V _{TSt} frees the device to accept a new tone pair. The GT output acts to reset the external steering time constant, and its state is a function of ES _t and the voltage on St. (See Figure 7).	
18	V _{DD}	Positive power supply. (Normally connected to +5V.)	
* -02 and -03 only, Connect to V _{SS} for -01 version			

Figure 4. The timing requirements for most telecommunication applications are satisfied with this circuit. Different steering arrangements may be used to select independently the guard times for tone-present (t_{GTP}) and tone-absent (t_{GTA}). This may be necessary to meet system specifications that place both accept and reject limits on both tone duration and interdigit pause.

Guard time adjustment also allows the designer to tailor system parameters such as talkoff and noise immunity. Increasing t_{REC} improves talkoff performance, since it reduces the probability that tones simulated by speech will maintain signal condition long enough to be registered. On the other hand, a relatively short t_{REC} with a long t_{DO} would be appropriate for extremely noisy environments where fast acquisition time and immunity to dropouts would be required. Design information for guard time adjustment is shown in Figure 4.

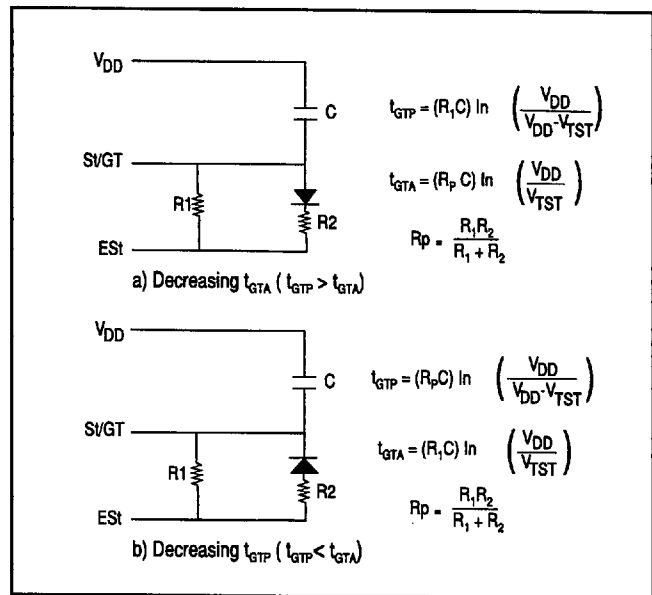

Figure 4 Guard Time Adjustment

Table 2 Absolute Maximum Ratings

PARAMETER	SYMBOL	VALUE
Power supply voltage ($V_{DD} - V_{SS}$)	V_{DD}	6.0 V max
Voltage on any pin	V_{dc}	$V_{SS} - 0.3, V_{DD} + 0.3$
Current on any pin	I_{DD}	10 mA max
Operating temperature	T_A	-40° C to + 85° C
Storage temperature	T_s	-65° C to + 150° C

Table 3 DC Characteristics

PARAMETER	SYMBOL	MIN	‡TYP	MAX	UNITS	TEST CONDITIONS
Operating supply voltage	V_{DD}	4.75		5.25	V	
Operating supply current	I_{DD}		3.0	7.0	mA	
Standby supply current (see Note 3)	I_{DDQ}			100	μ A	$PD = V_{DD}$
Power consumption	P_O		15	35	mW	$f = 3.579$ MHz, $V_{DD} = 5.0$ V
Low level input voltage	V_{IL}			1.5	V	
High level input voltage	V_{IH}	3.5			V	
Input leakage current	I_{IH}/I_{IL}		0.1		μ A	$V_{IN} = V_{SS}$ or V_{DD} (see Note 2)
Pullup (source) current on OE	I_{SO}		6.5	15.0	μ A	OE = 0 V
Input impedance, signal inputs 1, 2	R_{IN}	8	10		M Ω	@ 1 kHz
Steering threshold voltage	V_{TSI}	2.2		2.5	V	
Low level output voltage	V_{OL}			0.03	V	No load
High level output voltage	V_{OH}	4.97			V	No load
Output low (sink) current	I_{OL}	1.0	2.5		mA	$V_{OUT} = 0.4$ V
Output high (source) current	I_{OH}	0.4	0.8		mA	$V_{OUT} = 4.6$ V
Output voltage V_{REF}	V_{REF}	2.4		2.7	V	No load
Output resistance V_{REF}	R_{OR}		10		k Ω	

‡ Typical figures are at 25°C and are for design aid only: not guaranteed and not subject to production testing.

Notes: 1. All voltages referenced to V_{SS} unless otherwise noted. For typical values, $V_{DD} = 5.0$ V, $V_{SS} = 0$ V, $T_A = 25^\circ$ C.

2. Input pins defined as IN+, IN-, or OE.

3. -02 and -03, only.

Table 4 Operating Characteristics - Gain Setting Amplifier

PARAMETER	SYMBOL	MIN	‡ TYP	MAX	UNITS	TEXT CONDITIONS
Input leakage current	I_N		± 100		nA	$V_{SS} < V_{IN} < V_{DD}$
Input resistance	R_{IN}	4			M Ω	
Input offset voltage	V_{OS}		± 25		mV	
Power supply rejection	PSRR	50			dB	1 kHz
Common mode rejection	CMRR	55			dB	-3.0 V < V_{IN} < 3.0 V
DC open loop voltage gain	A_{VOL}	60			dB	
Open loop unity gain bandwidth	f_c	1.2	1.5		MHz	
Output voltage swing	V_O	3.5			V _{P-P}	$R_L \geq 100$ k Ω to V_{SS}
Tolerable capacitive load (GS)	C_L			100	pF	
Tolerable resistive load (GS)	R_L			50	k Ω	
Common mode range	V_{CM}	2.5			V _{P-P}	No load

All voltages referenced to V_{SS} unless otherwise noted. For typical values $V_{DD} = 5.0$ V, $V_{SS} = 0$ V, $T_A = 25^\circ$ C.

‡ Typical figures are at 25°C and are for design aid only: not guaranteed and not subject to production testing.

Table 5 Tone Decoding

FLOW	FHIGH	KEY (ref.)	OE	Q4	Q3	Q2	Q1
697	1209	1	H	0	0	0	1
697	1336	2	H	0	0	1	0
697	1477	3	H	0	0	1	1
770	1209	4	H	0	1	0	0
770	1336	5	H	0	1	0	1
770	1477	6	H	0	1	1	0
852	1209	7	H	0	1	1	1
852	1336	8	H	1	0	0	0
852	1477	9	H	1	0	0	1
941	1336	0	H	1	0	1	0
941	1209	*	H	1	0	1	1
941	1477	#	H	1	1	0	0
697	1633	A	H	1	1	0	1
770	1633	B	H	1	1	1	0
852	1633	C	H	1	1	1	1
941	1633	D	H	0	0	0	0
ANY	ANY	ANY	L	Z	Z	Z	Z

L = logic low, H = logic high, Z = high impedance

Power-down and Inhibit Mode (-02 and -03 only)

A logic high applied to pin 6 (PD) will place the device into standby mode to minimize power consumption. It stops the oscillator and the functioning of the filters. On -01 models, this pin is tied to ground (logic low).

Inhibit mode is enabled by a logic high input to pin 5 (INH). It inhibits the detection of 1633 Hz. The output code will remain the same as the previous detected code (see Table 1). On -01 models, this pin is tied to ground (logic low).

Input Configuration

The input arrangement of the M-8870 provides a differential input operational amplifier as well as a bias source (VREF) to bias the inputs at mid-rail. Provision is made for connection

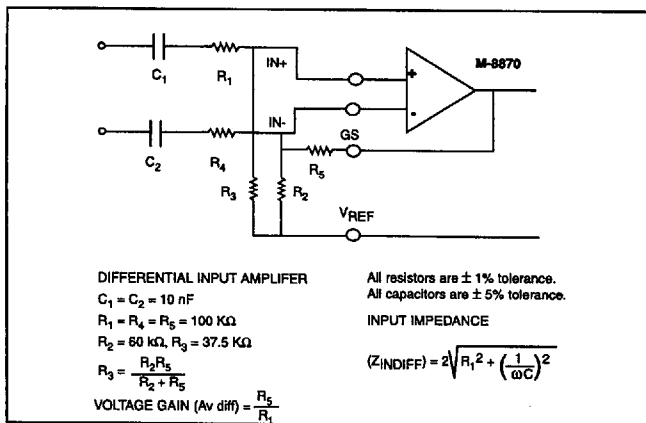

Figure 5 Differential Input Configuration

of a feedback resistor to the op-amp output (GS) for gain adjustment.

In a single-ended configuration, the input pins are connected as shown in Figure 3 with the op-amp connected for unity gain and VREF biasing the input at 1/2VDD. Figure 5 shows the differential configuration, which permits gain adjustment with the feedback resistor R5.

DTMF Clock Circuit

The internal clock circuit is completed with the addition of a standard 3.579545 MHz television color burst crystal. The crystal can be connected to a single M-8870 as shown in Figure 3, or to a series of M-8870s. As illustrated in Figure 6, a single crystal can be used to connect a series of M-8870s by coupling the oscillator output of each M-8870 through a 30 pF capacitor to the oscillator input of the next M-8870.

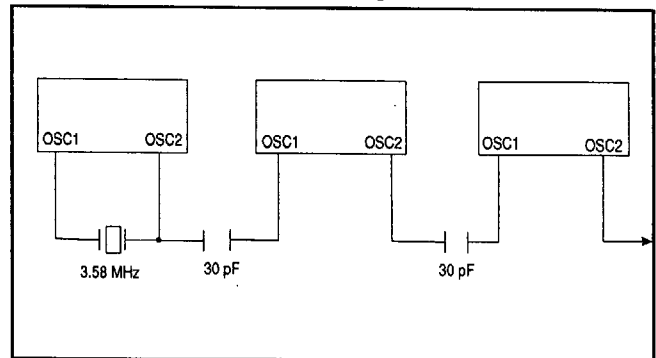

Figure 6 Common Crystal Connection

Table 6 AC Specifications

PARAMETER	SYMBOL	MIN	‡TYP	MAX	UNITS	NOTES
Valid input signal levels (each tone of composite signal) (-01 and -02 only)		-29		+1	dBm	1,2,3,4,5,8
		27.5		869	mVRMS	
Valid input signal levels (each tone of composite signal) (-03 only)		-40		+1	dBm	1,2,3,4,5,8
		7.75		869	mVRMS	
Positive twist accept				10	dB	2,3,4,8
Negative twist accept				10	dB	
Frequency deviation accept limit				$\pm 1.5\% + 2$ Hz	Nom.	2,3,5,8,10
Frequency deviation reject limit		$\pm 3.5\%$			Nom.	2,3,5
Third tone tolerance		-25	-16		dB	2,3,4,5,8,9,13,14
Noise tolerance			-12		dB	2,3,4,5,6,8,9
Dial tone tolerance		+18	+22		dB	2,3,4,5,7,8,9
Tone present detection time	tDP	5	8	14	ms	See Figure 7
Tone absent detection time	tDA	0.5	3	8.5	ms	
Minimum tone duration accept	tREC			40	ms	User adjustable (see Figures 2 and 4)
Maximum tone duration reject	tREC	20			ms	
Minimum interdigit pause accept	tID			40	ms	
Maximum interdigit pause reject	tDO	20			ms	
Propagation delay (St to Q)	tPQ		6	11	μ s	OE = V _{DD}
Propagation delay (St to StD)	tPStD		9	16	μ s	
Output data setup (Q to StD)	tQStD		4.0		μ s	
Propagation delay (OE to Q), enable	tPTE		50	60	ns	R _L = 10k Ω , C _L = 50 pF
Propagation delay (OE to Q), disable	tPTD		300		ns	
Crystal clock frequency	fCLK	3.5759	3.5795	3.5831	MHz	
Clock output (OSC2), capacitive load	C _{LO}			30	pF	

All voltages referenced to V_{SS} unless otherwise noted. For typical values V_{DD} = 5.0 V, V_{SS} = 0 V, T_A = 25 °C, fCLK = 3.579545 MHz.
‡Typical figures are at 25°C and are for design aid only: not guaranteed and not subject to production testing.

Notes:

1. dBm = decibels above or below a reference power of 1 mW into a 600 ohm load.
2. Digit sequence consists of all 16 DTMF tones.
3. Tone duration = 40 ms. Tone pause = 40 ms.
4. Nominal DTMF frequencies are used, measured at GS.
5. Both tones in the composite signal have an equal amplitude.
6. Bandwidth limited (0 to 3 kHz) Gaussian noise.
7. The precise dial tone frequencies are (350 and 440 Hz) $\pm 2\%$.
8. For an error rate of better than 1 in 10,000.
9. Referenced to lowest level frequency component in DTMF signal.
10. Minimum signal acceptance level is measured with specified maximum frequency deviation.
11. Input pins defined as IN+, IN-, and OE.
12. External voltage source used to bias V_{REF}.
13. This parameter also applies to a third tone injected onto the power supply.
14. Referenced to Figure 3. Input DTMF tone level at -28 dBm.

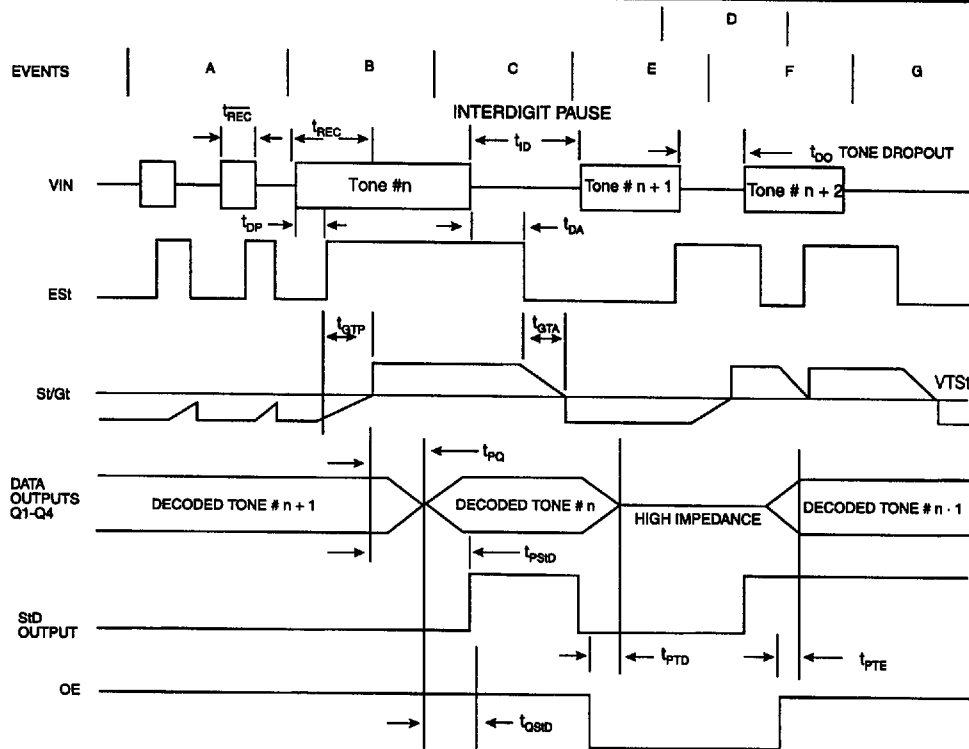

Explanation of Events

- (A) Tone bursts detected, tone duration invalid, outputs not updated.
- (B) Tone #n detected, tone duration valid, tone decoded and latched in outputs.
- (C) End of tone #n detected, tone absent duration valid, outputs remain latched until next valid tone.
- (D) Outputs switched to high impedance state.
- (E) Tone #n + 1 detected, tone duration valid, tone decoded and latched in outputs (currently high impedance).
- (F) Acceptable dropout of tone #n + 1, tone absent duration invalid, outputs remain latched.
- (G) End of tone #n + 1 detected, tone absent duration valid, outputs remain latched until next valid tone.

Explanation of Symbols

VIN	DTMF composite input signal.
ESst	Early steering output. Indicates detection of valid tone frequencies.
St/GT	Steering input/guard time output. Drives external RC timing circuit.
Q1 - Q4	4-bit decoded tone output.
StD	Delayed steering output. Indicates that valid frequencies have been present/absent for the required guard time, thus constituting a valid signal.
<u>OE</u>	Output enable (input). A low level shifts Q1 - Q4 to its high impedance state.
tREC	Maximum DTMF signal duration not detected as valid.
tREC	Minimum DTMF signal duration required for valid recognition.
tID	Minimum time between valid DTMF signals.
tDO	Maximum allowable dropout during valid DTMF signal.
tDP	Time to detect the presence of valid DTMF signals.
tDA	Time to detect the absence of valid DTMF signals.
tGTP	Guard time, tone present.
tGTA	Guard time, tone absent.

Figure 7 Timing Diagram

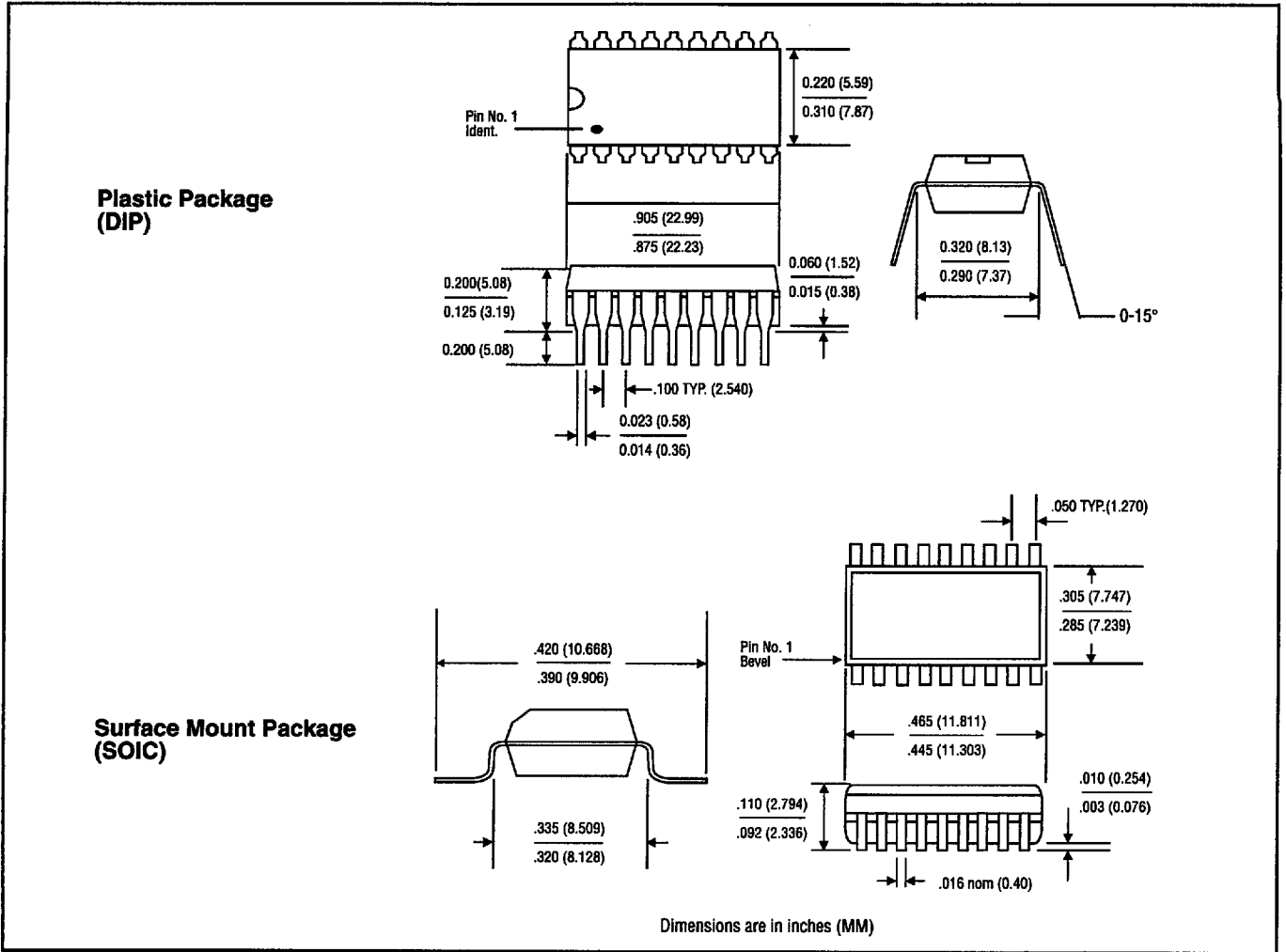

Figure 8 Package Dimensions

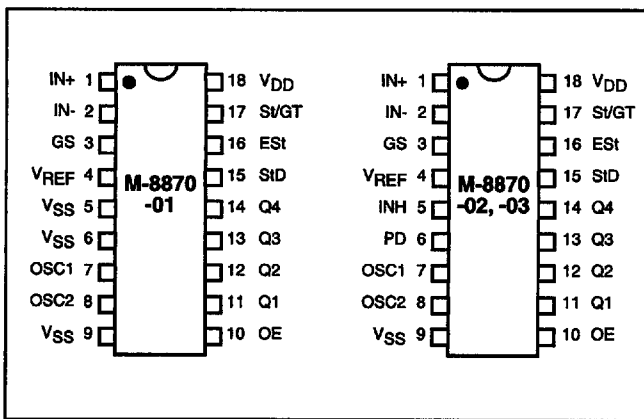

Figure 9 Pin Connections

Ordering Information

- M-8870-01 18-pin plastic DIP
- M-8870-01SM 18-pin plastic SOIC
- M-8870-01SMTR 18-pin plastic SOIC, tape and reel
- M-8870-02 18-pin plastic DIP, Power Down Option
- M-8870-02SM 18-pin plastic SOIC, Power Down Option
- M-8870-02SMTR 18-pin plastic SOIC, Power Down Option, tape and reel
- M-8870-03P 18-pin plastic DIP, Power Down Option
- M-8870-03S 18-pin plastic SOIC, Power Down Option
- M-8870-03T 18-pin plastic SOIC, Power Down Option, tape and reel