

# 16-Bit A/D Converter - Radiation Hardened 5016RP

Self-Calibrating  
High Speed CMOS

## For Space Applications

SEI's 5016RP (RP for RAD-PAK®) high speed CMOS microcircuit features a minimum 100 kilorad(Si) total dose tolerance. Fully equivalent to the commercial 5016, the 5016RP combines Crystal Semiconductor's advanced

CMOS process and SEI's radiation hardened RAD-PAK® packaging. This device offers a unique self-calibration circuitry which insures excellent linearity and differential nonlinearity, with no missing codes. Offset and full scale errors are kept within 1 LSB, which helps eliminate the need for calibration. Unipolar and bipolar input ranges are digitally selectable. Capable of surviving space environments, the 5016RP is ideal for satellite, spacecraft, and space probe missions. The patented RAD-PAK® technology incorporates radiation shielding in the microcircuit package. It eliminates box shielding while providing lifetime in orbit. The 5016RP, capable of operational sample rates up to 50kHz, features the same system performance and architecture as the commercial Crystal Semiconductor's counterpart. It is available in Class S packaging and screening.

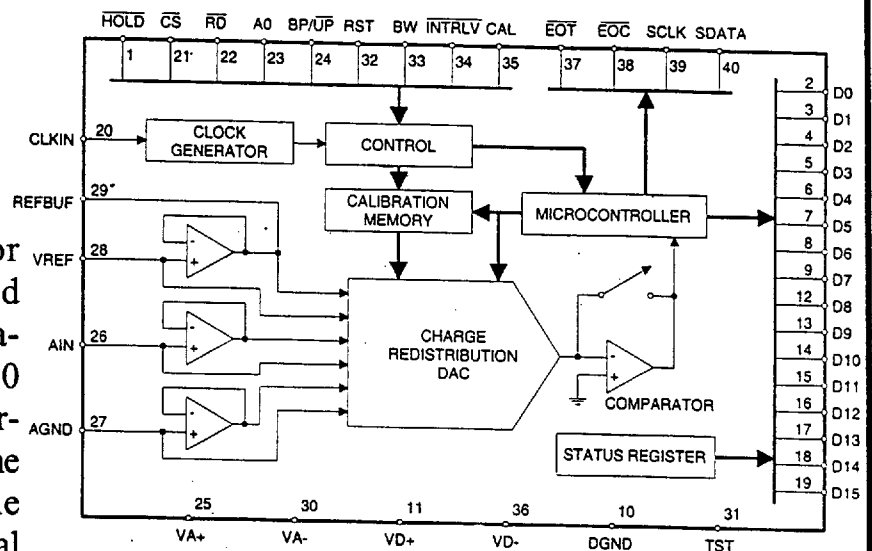

SPACE  
ELECTRONICS  
INCORPORATED

Tel: (619) 452-4167 Fax: (619) 452-5499  
INTERNET: 102005.1635@COMPUSERVE.COM

# Radiation Hardened 5016RP

Self-Calibrating  
High Speed CMOS

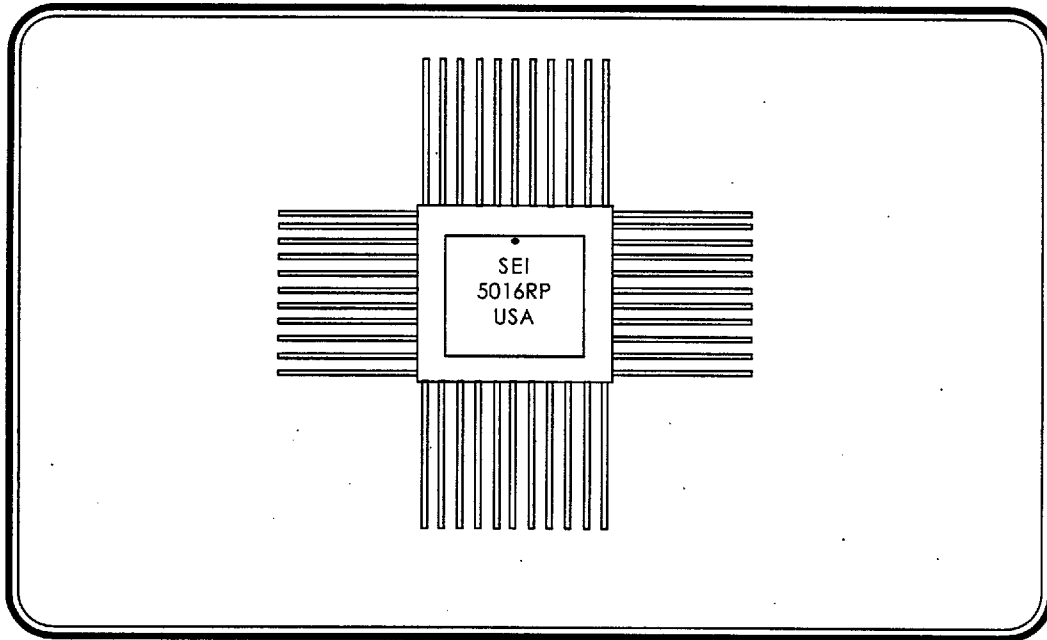

## Features:

- High Speed: 16.25 usec conversion time
- Pin Compatible to Crystal CS5016
- RAD-PAK® Radiation Hardened Against Natural Space Radiation
- Total Dose Hardness >100 krad (Si)
- Package:
  - 44 Pin RAD-PAK® quad flat pack (0.655 in. x 0.650 in.)
  - Weight - 8.2 grams
  - 40 Pin RAD-PAK® DIP (2.0 in. x 100 mil pitch)
  - Weight - 11.2 grams
- Low Power CMOS Technology
  - 120 mW Typical
- Monolithic CMOS A/D Converter
  - Inherent Sampling Architecture
  - Microprocessor Interface
  - Parallel and Serial Output
  - Self Calibration Maintains Accuracy Over Time and Temperature
- True 16-Bit Precision
  - Linearity Error: +0.001% FS
  - No Missing Codes
  - S/(N+D): 92 dB
  - THD: 0.001%
- Screening per TM 5004
- QCI per TM5005

Specifications and design are subject to change without notice.



August 1995

For Further Information Contact:

**Space Electronics Inc.**

4031 Sorrento Valley Blvd., San Diego, CA 92121  
(619) 452-4167 Fax (619) 452-5499  
INTERNET: 102005.1635@COMPUSERVE.COM

**5016RP ABSOLUTE MAXIMUM RATINGS<sup>1</sup>**

PARAMETER	SYMBOL	MIN	MAX	UNIT
DC Power Supplies:				
Positive Digital	VD+	-0.3	(VA+)+0.3	V
Negative Digital	VD-	0.3	-6.0	V
Positive Analog	VA+	-0.3	6.0	V
Negative Analog	VA-	0.3	-6.0	V
Input Current, Any Pin Except Supplies <sup>2</sup>	I <sub>in</sub>		±10	mA
Analog Input Voltage (AIN and VREF pins)	V <sub>INA</sub>	(VA-)-0.3	(VA+)+0.3	V
Digital Input Voltage	V <sub>IND</sub>	-0.3	(VA+)+0.3	V
Ambient Operating Temperature	T <sub>A</sub>	-55	125	°C
Storage Temperature	T <sub>stg</sub>	-65	150	°C

Notes:

1. AGND, DGND = 0V, all voltages are with respect to ground.
2. Transient currents of up to 100 mA will not cause SCR latch-up

**5016RP RECOMMENDED OPERATING CONDITIONS<sup>1</sup>**

PARAMETER	SYMBOL	MIN	TYP	MAX	UNIT
DC Power Supplies:					
Positive Digital	VD+	4.5	5.0	VA+	V
Negative Digital	VD-	-4.5	-5.0	-5.5	V
Positive Analog	VA+	4.5	5.0	5.5	V
Negative Analog	VA-	-4.5	-5.0	-5.5	V
Analog Reference Voltage	VREF	2.5	4.5	(VA+)-0.5	V
Analog Input Voltage <sup>2</sup> :					
Unipolar	V <sub>AIN</sub>	AGND		VREF	V
Bipolar	V <sub>AIN</sub>	-VREF		VREF	V

Note:

1. AGND, DGND = 0V, All voltages are with respect to ground.
2. It can accept input voltages up to the analog supplies (VA+ and VA-). It will output all 1's for inputs above VREF and all 0's for inputs below AGND in unipolar mode and -VREF in bipolar mode.



**SPACE ELECTRONICS INC.**

■ 9011241 0000325 541 ■ 324

4031 SORRENTO VALLEY BLVD.  
 SAN DIEGO, CA 92121  
 PHONE: (619) 452-4167  
 FAX: (619) 452-5499  
 INTERNET: 102005.1635@COMPUSERVE.COM

**5016RP ELECTRICAL PERFORMANCE CHARACTERISTICS**

PARAMETER	SYMBOL	MIN	MAX	UNITS
Resolution No Missing Codes Guaranteed <sup>1</sup>	RES	16		Bits
Integral Linearity Error <sup>1,2</sup>	INL		±5.0	LSB
Full-scale Error <sup>1,2</sup>	FSE		±4.0	LSB
Full-scale Error Drift <sup>1,2,3,4</sup>	dFSE/d <sub>t</sub>		±4.0	LSB
Unipolar Offset Error <sup>1,2</sup>	VOFF		±4.0	LSB
Unipolar Offset Error Drift <sup>1,2,3,4</sup>	dVOFF/d <sub>t</sub>		±2.0	LSB
Bipolar Offset Error <sup>1,2</sup>	BOFF		±4.0	LSB
Bipolar Offset Error Drift <sup>1,2,3,4</sup>	dBOFF/d <sub>t</sub>		±3.0	LSB
Bipolar Negative Full-scale Error <sup>1,2</sup>	BNFSE		±5.0	LSB
Bipolar Negative Full-scale Error Drift <sup>1,2,3,4</sup>	dBNFSE/d <sub>t</sub>		±3.0	LSB
Peak Harmonic or Spurious Noise 1kHz input, full scale amp., bipolar mode <sup>1,2</sup> 12kHz input, full scale amp., bipolar mode <sup>1,2</sup>	S/PN	92 82		dB dB
Signal to Noise Ratio <sup>1,2</sup> 1kHz input, full scale amp., bipolar mode	S/(N+D)	84		dB



**SPACE ELECTRONICS INC.**

■ 9011241 0000326 488 ■

4031 SORRENTO VALLEY BLVD.  
 SAN DIEGO, CA 92121  
 PHONE: (619) 452-4167  
 FAX: (619) 452-5499  
 INTERNET: 102005.1635@COMPUSERVE.COM

5016RP ELECTRICAL PERFORMANCE CHARACTERISTICS (Continued)

PARAMETER	SYMBOL	MIN	MAX	UNIT
Analog Input Capacitance in Fine Charge Mode Unipolar Mode $T_A = +25^\circ\text{C}^{1,3}$ Bipolar Mode $T_A = +25^\circ\text{C}^{1,3}$	$C_{IN}$		375 220	pF
Digital Input Voltage <sup>5,6</sup>	$V_{IH}$ $V_{IL}$	2.0	0.8	V
Digital Input Current <sup>5,6</sup>	$I_{IN}$		$\pm 10$	$\mu\text{A}$
Digital Output Voltage Logic "0", $I_{SINK} = -1.6\text{mA}^{5,6}$ Logic "1", $I_{SOURCE} = 100\mu\text{A}^{5,6}$	$V_{OL}$ $V_{OH}$	$+V_D - 1.0$	0.4	V
High Impedance State Output Current <sup>5,6</sup> Pins $D_0$ to $D_{15}$ only	$I_{OZ}$		$\pm 10$	$\mu\text{A}$
Conversion Time <sup>1,6,7</sup>	$t_C$		16.25	$\mu\text{s}$
Acquisition Time $T_A = +25^\circ\text{C}^{1,2,3,8}$	$t_{ACQ}$		3.75	$\mu\text{s}$
Throughput <sup>1,2,6</sup>	$t_{PLT}$	50		kHz
Positive Analog Supply Current <sup>6,9</sup> $+V_A, +V_D = 5.5\text{V}$ $-V_A, -V_D = -5.5\text{V}$	$I_{A+}$		19.0	mA
Negative Analog Supply Current <sup>6,9</sup> $+V_A, +V_D = 5.5\text{V}$ $-V_A, -V_D = -5.5\text{V}$	$I_{A-}$		19.0	mA



**SPACE ELECTRONICS INC.**

■ 9011241 0000327 314 ■

4031 SORRENTO VALLEY BLVD.  
SAN DIEGO, CA 92121  
PHONE: (619) 452-4167  
FAX: (619) 452-5499  
INTERNET: 102005.1635@COMPUSERVE.COM

5016RP ELECTRICAL PERFORMANCE CHARACTERISTICS (Continued)

PARAMETER	SYMB OL	MIN	MAX	UNIT
Positive Digital Supply Current <sup>6,9</sup> +V <sub>A</sub> , +V <sub>D</sub> =5.5V -V <sub>A</sub> , -V <sub>D</sub> =-5.5V	I <sub>D+</sub>		6.0	mA
Negative Digital Supply Current <sup>6,9</sup> +V <sub>A</sub> , +V <sub>D</sub> =5.5V -V <sub>A</sub> , -V <sub>D</sub> =-5.5V	I <sub>D-</sub>		6.0	mA
Master Clock Frequency <sup>10</sup> Internally Generated, CLKIN=0V dc, +V <sub>D</sub> , +V <sub>A</sub> =4.5V, T <sub>A</sub> =-55°C, -V <sub>D</sub> , -V <sub>A</sub> =-4.5V	f <sub>CLK</sub>	1.75		MHz
HOLD\ Pulse Width <sup>5,6,11</sup>	t <sub>HPW</sub>	1/f <sub>CLK</sub> +50	t <sub>c</sub>	ns
Data Delay Time <sup>5,6,11</sup>	t <sub>DD</sub>		100	ns
EOC\ Pulse Width <sup>5,6,11</sup>	t <sub>EPW</sub>	4/f <sub>CLK</sub> -20		ns
CAL, INTRLV\ to CS\ Low Setup Time <sup>5,6,11</sup>	t <sub>CS</sub>	20		ns
AO to CS\ and RD\ Low Setup Time <sup>5,6,11</sup>	t <sub>AS</sub>	20		ns
CS\ or RD\ High to AO Invalid Hold Time <sup>5,6,11</sup>	t <sub>AH</sub>	50		ns
CS\ High To CAL, INTRLV\ Invalid Hold Time <sup>5,6,11</sup>	t <sub>CH</sub>	50		ns
CS\ Low to Data Valid Access Time <sup>5,6,11</sup> RD\=logic "0"	t <sub>CA</sub>		250	ns
RD\ Low to Data Valid Access Time <sup>5,6,11</sup> CS\=logic "0"	t <sub>RA</sub>		250	ns



**SPACE ELECTRONICS INC.**

4031 SORRENTO VALLEY BLVD.  
SAN DIEGO, CA 92121  
PHONE: (619) 452-4167  
FAX: (619) 452-5499  
INTERNET: 102005.1635@COMPUSERVE.COM



**5016RP ELECTRICAL PERFORMANCE CHARACTERISTICS (Continued)**

PARAMETER	SYMBOL	MIN	MAX	UNIT
Output Float Delay <sup>5,6,11</sup>	$t_{FD}$		250	ns
SDATA to SCLK Rising Setup Time <sup>5,6,11</sup>	$t_{SS}$	$2/f_{CLK}$ -50		ns
SCLK Rising to SDATA Hold Time <sup>5,6,11</sup>	$t_{SH}$	$2/f_{CLK}$ -100		ns

Notes:

1.  $+V_A, +V_D = +5.0V$ ;  $-V_A, -V_D = -5.0V$ ;  $V_{REF} = +4.5V$  dc;  $f_{CLK} = 4MHz$ ; analog source impedance =  $200\Omega$ ; error tests are done after calibration at the temperature of interest.
2. Synchronous sampling mode (EOT\ connected to HOLD\), interleave disabled.
3. This parameter shall be measured only for initial characterization and after process or design changes which may affect this parameter.
4. Total drift over  $-55^\circ C$  to  $+125^\circ C$  since calibration at power-up at  $+25^\circ C$ .
5.  $+V_A, +V_D = +5.0V$  dc  $\pm 10\%$ ;  $-V_A, -V_D = -5.0V$  dc  $\pm 10\%$ .
6. This parameter is guaranteed, if not tested, at  $T_A = +25^\circ C$ . This parameter is tested at  $T_A = -55^\circ C$  and  $125^\circ C$ .
7. Measured from falling transition on HOLD\ to falling transition on EOC\.
8. Acquisition time is the time allowed by the converter for acquisition of the input voltage prior to conversion.
9. All outputs unloaded; all inputs swinging between  $+V_D$  and  $0V$  dc.
10. Externally supplied maximum clock frequency is  $4MHz$ . Analog parametric measurements are done with the maximum external clock (See 1 above).
11. Inputs: logic "0" =  $0V$ , logic "1" =  $+V_D$ ;  $C_L = 50pF$ .

**5016RP Package Ordering Guide**

Package Style	Case Outline	1/	Description
D	D-40		40 Pin Dual In Line Package
Q	Q-44		44 Pin Quad Flat Package

Note:

- 1/ For outline information, see Appendix A (Package Information - Outline Dimension)



**SPACE ELECTRONICS INC.**

■ 9011241 0000330 909 ■

3288

4031 SORRENTO VALLEY BLVD.  
 SAN DIEGO, CA 92121  
 PHONE: (619) 452-4167  
 FAX: (619) 452-5499  
 INTERNET: 102005.1635@COMPUSERVE.COM

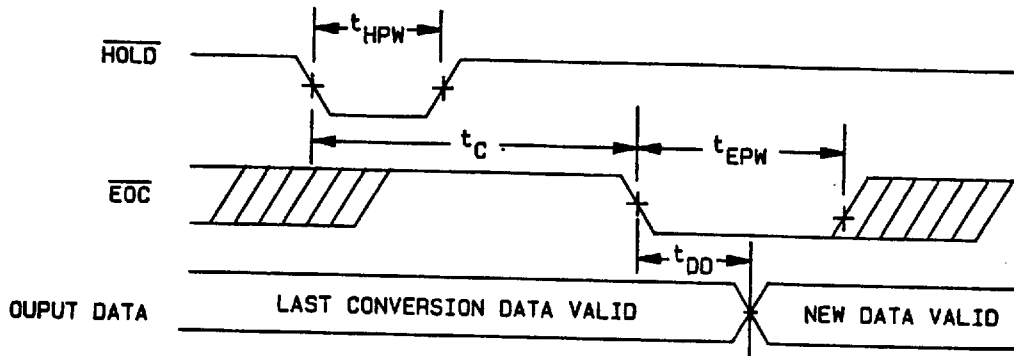

FIGURE 4. Conversion timing.

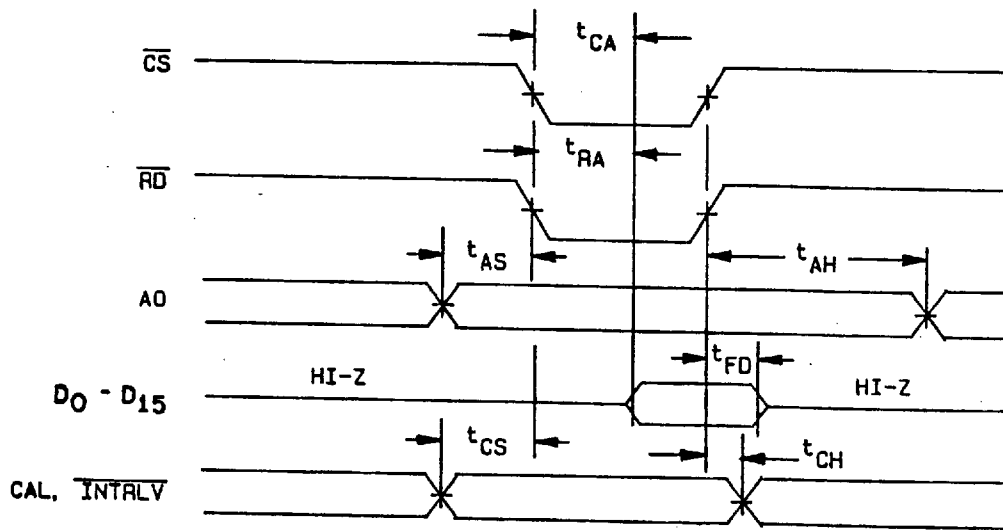

FIGURE 5. Read and calibration control timing.

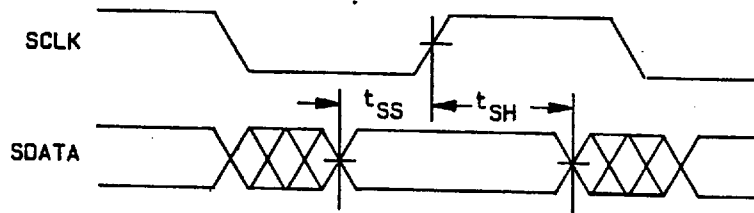

FIGURE 6. Serial output timing.



**SPACE ELECTRONICS INC.**

9011241 0000331 845 329

4031 SORRENTO VALLEY BLVD.  
 SAN DIEGO, CA 92121  
 PHONE: (619) 452-4167  
 FAX: (619) 452-5499  
 INTERNET: 102005.1635@COMPUSERVE.COM

