

CMOS BCD-to-7-Segment Latch Decoder Drivers

December 1992

Features

- High Voltage Type (20V Rating)
- High Output Sourcing Capability up to 25mA
- Input Latches for BCD Code Storage
- Lamp Test and Blanking Capability
- 7 Segment Outputs Blanked for BCD Input Codes > 1001
- 100% Tested for Quiescent Current at 20V
- 5V, 10V and 15V Parametric Ratings
- Maximum Input Current of 1 μ A at 18V Over Full Package Temperature Range; 100nA at 18V and +25°C

Applications

- Driving Common Cathode LED Displays
- Multiplexing with Common Cathode LED Displays
- Driving Incandescent Displays
- Driving Low Voltage Fluorescent Displays

Description

CD4511BMS is a BCD-to-7-Segment latch decoder drivers constructed with CMOS logic and n-p-n bipolar transistor output devices on a single monolithic structure. These devices combine the low quiescent power dissipation and high noise immunity features of Harris CMOS with n-p-n bipolar output transistors capable of sourcing up to 25mA. This capability allows the CD4511BMS types to drive LED's and other displays directly.

Lamp Test (\overline{LT}), Blanking (\overline{BL}), and Latch Enable or Strobe inputs are provided to test the display, shut off or intensity modulate it, and store or strobe a BCD code, respectively. Several different signals may be multiplexed and displayed when external multiplexing circuitry is used.

These devices are similar to the type MC14511.

The CD4511BMS is supplied in these 16-lead outline packages:

Braze Seal DIP	H4W
Frit Seal DIP	H2R
Ceramic Flatpack	H6W

Pinout

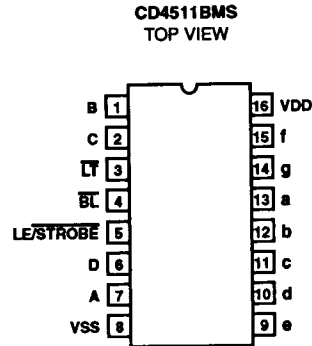

Functional Diagram

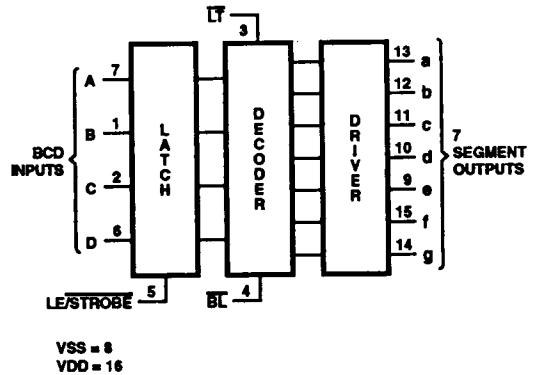

7-Segment Display



Specifications CD4511BMS

Absolute Maximum Ratings

DC Supply Voltage Range, (VDD) -0.5V to +20V
 (Voltage Referenced to VSS Terminals)
 Input Voltage Range, All Inputs -0.5V to VDD +0.5V
 DC Input Current, Any One Input ±10mA
 Operating Temperature Range -55°C to +125°C
 Package Types D, F, K, H
 Storage Temperature Range (TSTG) -65°C to +150°C
 Lead Temperature (During Soldering) +265°C
 At Distance 1/16 ± 1/32 inch (1.59mm ± 0.79mm) from case for
 10s Maximum

Reliability Information

Thermal Resistance θ_{JA} θ_{JC}
 Ceramic DIP and FRIT Package 80°C/W 20°C/W
 Flatpack Package 70°C/W 20°C/W
 Maximum Package Power Dissipation (PD) at +125°C
 For $T_A = -55^\circ\text{C}$ to +100°C (Package Type D, F, K) 500mW
 For $T_A = +100^\circ\text{C}$ to +125°C (Package Type D, F, K) Derate
 Linearity at 12mW/°C to 200mW
 Device Dissipation per Output Transistor 100mW
 For $T_A = \text{Full Package Temperature Range (All Package Types)}$
 Junction Temperature +175°C

TABLE 1. DC ELECTRICAL PERFORMANCE CHARACTERISTICS

PARAMETER	SYMBOL	CONDITIONS (NOTE 1)		GROUP A SUBGROUPS	TEMPERATURE	LIMITS		UNITS
						MIN	MAX	
Supply Current	IDD	VDD = 20V, VIN = VDD or GND		1	+25°C	-	10	µA
				2	+125°C	-	1000	µA
		VDD = 18V, VIN = VDD or GND		3	-55°C	-	10	µA
Input Leakage Current	IIL	VIN = VDD or GND	VDD = 20	1	+25°C	-100	-	nA
				2	+125°C	-1000	-	nA
			VDD = 18V	3	-55°C	-100	-	nA
Input Leakage Current	IIH	VIN = VDD or GND	VDD = 20	1	+25°C	-	100	nA
				2	+125°C	-	1000	nA
			VDD = 18V	3	-55°C	-	100	nA
Output Voltage	VOL15	VDD = 15V, No Load		1, 2, 3	+25°C, +125°C, -55°C	-	50	mV
Output Voltage	VOH15	VDD = 15V, No Load (Note 3)		1	+25°C	14.1	-	V
				2	+125°C	14.2	-	V
				3	-55°C	14.0	-	V
Output Current (Sink)	IOL5	VDD = 5V, VOUT = 0.4V		1	+25°C	1	-	mA
Output Current (Sink)	IOL10	VDD = 10V, VOUT = 0.5V		1	+25°C	2.6	-	mA
Output Current (Sink)	IOL15	VDD = 15V, VOUT = 1.5V		1	+25°C	6.8	-	mA
Output Drive Voltage	LVOH5	VDD = 5V, IOH = -20mA		1	+25°C	3.4	-	V
Output Drive Voltage	LVOH10	VDD = 10V, IOH = -20mA		1	+25°C	8.6	-	V
Output Drive Voltage	LVOH15	VDD = 15V, IOH = -20mA		1	+25°C	13.7	-	V
N Threshold Voltage	VNTH	VDD = 10V, ISS = -10µA		1	+25°C	-2.8	-0.7	V
P Threshold Voltage	VPTH	VSS = 0V, IDD = 10µA		1	+25°C	0.7	2.8	V
Functional	F	VDD = 2.8V, VIN = VDD or GND		7	+25°C	VOH > VDD/2	VOL < VDD/2	V
		VDD = 20V, VIN = VDD or GND		7	+25°C			
		VDD = 18V, VIN = VDD or GND		8A	+125°C			
		VDD = 3V, VIN = VDD or GND		8B	-55°C			
Input Voltage Low (Note 2)	VIL	VDD = 5V, VOH > 3.6V, VOL < 0.5V		1, 2, 3	+25°C, +125°C, -55°C	-	1.5	V
Input Voltage High (Note 2)	VIH	VDD = 5V, VOH > 3.6V, VOL < 0.5V		1, 2, 3	+25°C, +125°C, -55°C	3.5	-	V
Input Voltage Low (Note 2)	VIL	VDD = 15V, VOH > 12.6V, VOL < 1.5V		1, 2, 3	+25°C, +125°C, -55°C	-	4	V
Input Voltage High (Note 2)	VIH	VDD = 15V, VOH > 12.6V, VOL < 1.5V		1, 2, 3	+25°C, +125°C, -55°C	11	-	V

NOTES: 1. All voltages referenced to device GND, 100% testing being implemented. 2. Go/No Go test with limits applied to inputs. 3. For accuracy, voltage is measured differentially to VDD

Specifications CD4511BMS

TABLE 2. AC ELECTRICAL PERFORMANCE CHARACTERISTICS

PARAMETER	SYMBOL	CONDITIONS (NOTE 1, 2)	GROUP A SUBGROUPS	TEMPERATURE	LIMITS		UNITS
					MIN	MAX	
Propagation Delay Data to Output	TPHL	VDD = 5V, VIN = VDD or GND	9	+25°C	-	1040	ns
			10, 11	+125°C, -55°C	-	1404	ns
Propagation Delay Data to Output	TPLH	VDD = 5V, VIN = VDD or GND	9	+25°C	-	1320	ns
			10, 11	+125°C, -55°C	-	1782	ns
Transition Time	TTHL	VDD = 5V, VIN = VDD or GND	9	+25°C	-	310	ns
			10, 11	+125°C, -55°C	-	419	ns
Transition Time	TTLH	VDD = 5V, VIN = VDD or GND	9	+25°C	-	80	ns
			10, 11	+125°C, -55°C	-	108	ns

NOTES:

1. CL = 50pF, RL = 200K, Input TR, TF < 20ns.
2. -55°C and +125°C limits guaranteed, 100% testing being implemented.

TABLE 3. ELECTRICAL PERFORMANCE CHARACTERISTICS

PARAMETER	SYMBOL	CONDITIONS	NOTES	TEMPERATURE	LIMITS		UNITS
					MIN	MAX	
Supply Current	IDD	VDD = 5V, VIN = VDD or GND	1, 2	-55°C, +25°C	-	5	μA
				+125°C	-	150	μA
		VDD = 10V, VIN = VDD or GND	1, 2	-55°C, +25°C	-	10	μA
				+125°C	-	300	μA
		VDD = 15V, VIN = VDD or GND	1, 2	-55°C, +25°C	-	10	μA
				+125°C	-	600	μA
Output Voltage	VOL	VDD = 5V, No Load	1, 2	+25°C, +125°C, -55°C	-	50	mV
Output Voltage	VOL	VDD = 10V, No Load	1, 2	+25°C, +125°C, -55°C	-	50	mV
Output Voltage	VOH	VDD = 5V, No Load	1, 2	+25°C	4.1	-	V
			1, 2	+125°C	4.2	-	V
			1, 2	-55°C	4.0	-	V
Output Voltage	VOH	VDD = 10V, No Load	1, 2	+25°C	9.1	-	V
			1, 2	+125°C	9.2	-	V
			1, 2	-55°C	9.0	-	V
Output Current (Sink)	IOL5	VDD = 5V, VOUT = 0.4V	1, 2	+125°C	0.36	-	mA
				-55°C	0.64	-	mA
Output Current (Sink)	IOL10	VDD = 10V, VOUT = 0.5V	1, 2	+125°C	0.9	-	mA
				-55°C	1.6	-	mA
Output Current (Sink)	IOL15	VDD = 15V, VOUT = 1.5V	1, 2	+125°C	2.4	-	mA
				-55°C	4.2	-	mA
Input Voltage Low	VIL	VDD = 10V, VOH > 9V, VOL < 1V	1, 2	+25°C, +125°C, -55°C	-	3	V
Input Voltage High	VIH	VDD = 10V, VOH > 9V, VOL < 1V	1, 2	+25°C, +125°C, -55°C	+7	-	V

Specifications CD4511BMS

TABLE 3. ELECTRICAL PERFORMANCE CHARACTERISTICS(Continued)

PARAMETER	SYMBOL	CONDITIONS	NOTES	TEMPERATURE	LIMITS		UNITS	
					MIN	MAX		
Propagation Delay Data to Output	TPHL	VDD = 10V	1, 2, 3	+25°C	-	420	ns	
		VDD = 15V	1, 2, 3	+25°C	-	300	ns	
Propagation Delay Data to Output	TPLH	VDD = 10V	1, 2, 3	+25°C	-	520	ns	
		VDD = 15V	1, 2, 3	+25°C	-	360	ns	
Propagation Delay (BT)	TPHL	VDD = 5V	1, 2, 3	+25°C	-	700	ns	
		VDD = 10V	1, 2, 3	+25°C	-	350	ns	
		VDD = 15V	1, 2, 3	+25°C	-	250	ns	
Propagation Delay (BT)	TPLH	VDD = 5V	1, 2, 3	+25°C	-	800	ns	
		VDD = 10V	1, 2, 3	+25°C	-	350	ns	
		VDD = 15V	1, 2, 3	+25°C	-	300	ns	
Propagation Delay (LT)	TPHL	VDD = 5V	1, 2, 3	+25°C	-	500	ns	
		VDD = 10V	1, 2, 3	+25°C	-	250	ns	
		VDD = 15V	1, 2, 3	+25°C	-	170	ns	
Propagation Delay (LT)	TPLH	VDD = 5V	1, 2, 3	+25°C	-	300	ns	
		VDD = 10V	1, 2, 3	+25°C	-	150	ns	
		VDD = 15V	1, 2, 3	+25°C	-	100	ns	
Transition Time	TTHL	VDD = 10V	1, 2, 3	+25°C	-	185	ns	
		VDD = 15V	1, 2, 3	+25°C	-	160	ns	
Transition Time	TTLH	VDD = 10V	1, 2, 3	+25°C	-	60	ns	
		VDD = 15V	1, 2, 3	+25°C	-	50	ns	
Minimum Data Setup Time	TS	VDD = 5V	1, 2, 3	+25°C	-	150	ns	
		VDD = 10V	1, 2, 3	+25°C	-	70	ns	
		VDD = 15V	1, 2, 3	+25°C	-	40	ns	
Minimum Data Hold Time	TH	VDD = 5V	1, 2, 3	+25°C	-	0	ns	
		VDD = 10V	1, 2, 3	+25°C	-	0	ns	
		VDD = 15V	1, 2, 3	+25°C	-	0	ns	
Minimum Strobe Pulse Width	TW	VDD = 5V	1, 2, 3	+25°C	-	400	ns	
		VDD = 10V	1, 2, 3	+25°C	-	160	ns	
		VDD = 15V	1, 2, 3	+25°C	-	100	ns	
Output Drive Voltage	LVOH5	VDD = 5V, IOH = -10mA	1, 2	+25°C	3.9	-	V	
			1, 2	+125°C	3.9	-	V	
			1, 2	-55°C	3.8	-	V	
		VDD = 5V, IOH = -20mA	1, 2	-55°C	3.55	-	V	
			VDD = 5V, IOH = -25mA	1, 2	+25°C	3.1	-	V
				1, 2	-55°C	3.4	-	V
Output Drive Voltage	LVOH10	VDD = 10V, IOH = -10mA	1, 2	+25°C	9.0	-	V	
			1, 2	+125°C	9.0	-	V	
			1, 2	-55°C	8.85	-	V	
		VDD = 10V, IOH = -20mA	1, 2	+125°C	8.4	-	V	
			1, 2	-55°C	8.7	-	V	
			VDD = 10V, IOH = -25mA	1, 2	+25°C	8.3	-	V
		1, 2		-55°C	8.6	-	V	

Specifications CD4511BMS

TABLE 3. ELECTRICAL PERFORMANCE CHARACTERISTICS(Continued)

PARAMETER	SYMBOL	CONDITIONS	NOTES	TEMPERATURE	LIMITS		UNITS
					MIN	MAX	
Output Drive Voltage	LVOH15	VDD = 15V, IOH = -10mA	1, 2	+25°C	14.0	-	V
			1, 2	+125°C	14.0	-	V
			1, 2	-55°C	13.9	-	V
		VDD = 15V, IOH = -20mA	1, 2	+125°C	13.5	-	V
			1, 2	-55°C	13.75	-	V
			VDD = 15V, IOH = -25mA	1, 2	+25°C	13.5	-
1, 2	-55°C	13.65		-	V		
Input Capacitance	CIN	Any Input	1, 2	+25°C	-	7.5	pF

NOTES:

1. All voltages referenced to device GND.
2. The parameters listed on Table 3 are controlled via design or process and are not directly tested. These parameters are characterized on initial design release and upon design changes which would affect these characteristics.
3. CL = 50pF, RL = 200K, Input TR, TF < 20ns.

TABLE 4. POST IRRADIATION ELECTRICAL PERFORMANCE CHARACTERISTICS

PARAMETER	SYMBOL	CONDITIONS	NOTES	TEMPERATURE	LIMITS		UNITS
					MIN	MAX	
Supply Current	IDD	VDD = 20V, VIN = VDD or GND	1, 4	+25°C	-	25	μA
N Threshold Voltage	VNTH	VDD = 10V, ISS = -10μA	1, 4	+25°C	-2.8	-0.2	V
N Threshold Voltage Delta	ΔVTN	VDD = 10V, ISS = -10μA	1, 4	+25°C	-	±1	V
P Threshold Voltage	VTP	VSS = 0V, IDD = 10μA	1, 4	+25°C	0.2	2.8	V
P Threshold Voltage Delta	ΔVTP	VSS = 0V, IDD = 10μA	1, 4	+25°C	-	±1	V
Functional	F	VDD = 18V, VIN = VDD or GND	1	+25°C	VOH > VDD/2	VOL < VDD/2	V
		VDD = 3V, VIN = VDD or GND					
Propagation Delay Time	TPHL TPLH	VDD = 5V	1, 2, 3, 4	+25°C	-	1.35 x +25°C Limit	ns

- NOTES: 1. All voltages referenced to device GND. 2. CL = 50pF, RL = 200K, Input TR, TF < 20ns. 3. See Table 2 for +25°C limit. 4. Read and Record

TABLE 5. BURN-IN AND LIFE TEST DELTA PARAMETERS +25°C

PARAMETER	SYMBOL	DELTA LIMIT
Supply Current - MSI-2	IDD	± 1.0μA
Output Current (Sink)	IOL5	± 20% x Pre-Test Reading
Output Current (Source)	IOH5A	± 20% x Pre-Test Reading

TABLE 6. APPLICABLE SUBGROUPS

CONFORMANCE GROUP	MIL-STD-883 METHOD	GROUP A SUBGROUPS	READ AND RECORD
Initial Test (Pre Burn-In)	100% 5004	1, 7, 9	IDD, IOL5, IOH5A
Interim Test 1 (Post Burn-In)	100% 5004	1, 7, 9	IDD, IOL5, IOH5A

Specifications CD4511BMS

TABLE 6. APPLICABLE SUBGROUPS (Continued)

CONFORMANCE GROUP		MIL-STD-883 METHOD	GROUP A SUBGROUPS	READ AND RECORD
Interim Test 2 (Post Burn-In)		100% 5004	1, 7, 9	IDD, IOL5, IOH5A
PDA (Note 1)		100% 5004	1, 7, 9, Deltas	
Interim Test 3 (Post Burn-In)		100% 5004	1, 7, 9	IDD, IOL5, IOH5A
PDA (Note 1)		100% 5004	1, 7, 9, Deltas	
Final Test		100% 5004	2, 3, 8A, 8B, 10, 11	
Group A		Sample 5005	1, 2, 3, 7, 8A, 8B, 9, 10, 11	
Group B	Subgroup B-5	Sample 5005	1, 2, 3, 7, 8A, 8B, 9, 10, 11, Deltas	Subgroups 1, 2, 3, 9, 10, 11
	Subgroup B-6	Sample 5005	1, 7, 9	
Group D		Sample 5005	1, 2, 3, 8A, 8B, 9	Subgroups 1, 2, 3

NOTE: 1. 5% Parametric, 3% Functional; Cumulative for Static 1 and 2.

TABLE 7. TOTAL DOSE IRRADIATION

CONFORMANCE GROUPS	MIL-STD-883 METHOD	TEST		READ AND RECORD	
		PRE-IRRAD	POST-IRRAD	PRE-IRRAD	POST-IRRAD
Group E Subgroup 2	5005	1, 7, 9	Table 4	1, 9	Table 4

TABLE 8. BURN-IN AND IRRADIATION TEST CONNECTIONS

FUNCTION	OPEN	GROUND	VDD	9V ± -0.5V	OSCILLATOR	
					50kHz	25kHz
Static Burn-In 1 (Note 1)	9-15	1-8	16			
Static Burn-In 2 (Note 1)	9-15	8	1-7, 16			
Dynamic Burn-In (Note 1)	9-15	5, 8	3, 4, 16	-	1, 2, 7	6
Irradiation (Note 2)	9-15	8	1-7, 16			

NOTES:

1. Each pin except VDD and GND will have a series resistor of $10K \pm 5\%$, $VDD = 18V \pm 0.5V$
2. Each pin except VDD and GND will have a series resistor of $47K \pm 5\%$; Group E, Subgroup 2, sample size is 4 dice/wafer, 0 failures, $VDD = 10V \pm 0.5V$

Logic Diagram

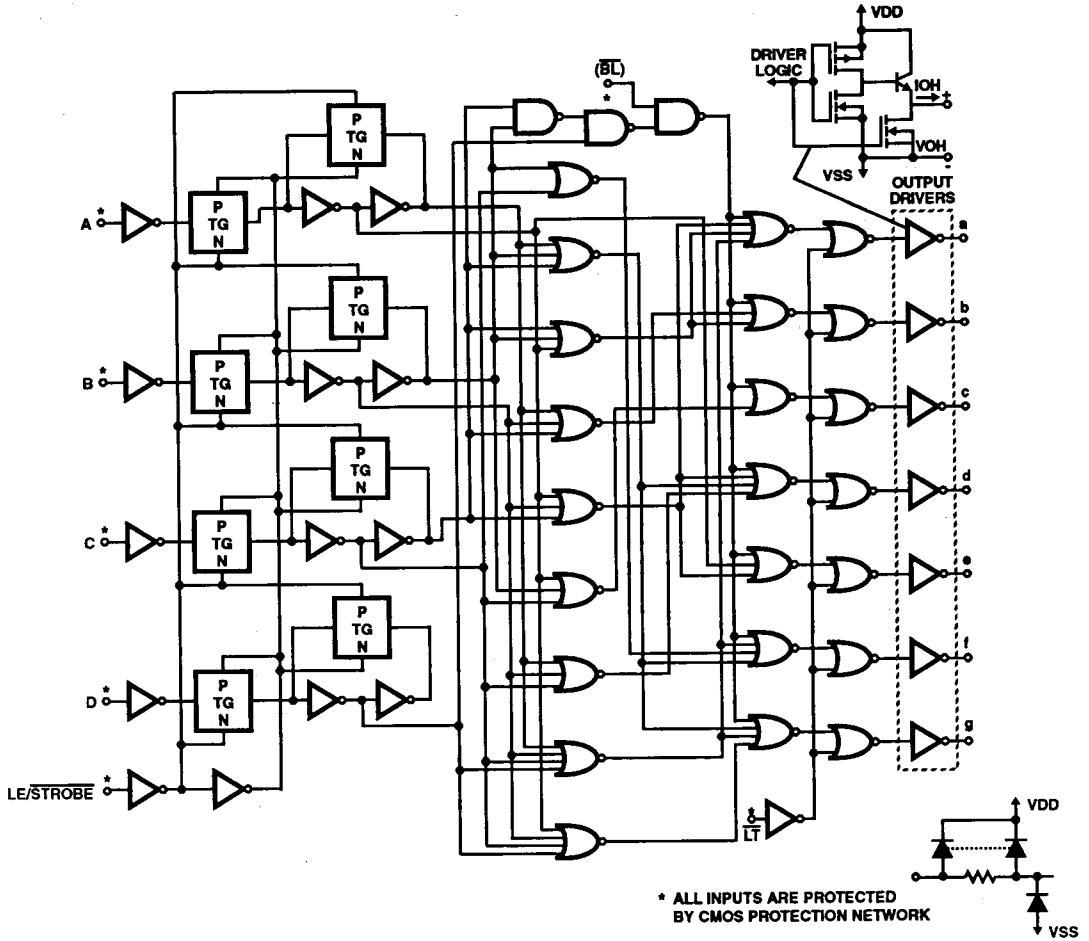

FIGURE 1.

TRUTH TABLE

LE	\overline{BI}	\overline{LT}	D	C	B	A	a	b	c	d	e	f	g	DISPLAY
X	X	0	X	X	X	X	1	1	1	1	1	1	1	8
X	0	1	X	X	X	X	0	0	0	0	0	0	0	Blank
0	1	1	0	0	0	0	1	1	1	1	1	1	0	0
0	1	1	0	0	0	1	0	1	1	0	0	0	0	1
0	1	1	0	0	1	0	1	1	0	1	1	0	1	2
0	1	1	0	0	1	1	1	1	1	1	0	0	1	3
0	1	1	0	1	0	0	0	1	1	0	0	1	1	4
0	1	1	0	1	0	1	1	0	1	1	0	1	1	5

CD4511BMS

TRUTH TABLE (Continued)

LE	\overline{BI}	\overline{LT}	D	C	B	A	a	b	c	d	e	f	g	DISPLAY
0	1	1	0	1	1	0	0	0	1	1	1	1	1	b
0	1	1	0	1	1	1	1	1	1	0	0	0	0	7
0	1	1	1	0	0	0	1	1	1	1	1	1	1	8
0	1	1	1	0	0	1	1	1	1	0	0	1	1	9
0	1	1	1	0	1	0	0	0	0	0	0	0	0	Blank
0	1	1	1	0	1	1	0	0	0	0	0	0	0	Blank
0	1	1	1	1	0	0	0	0	0	0	0	0	0	Blank
0	1	1	1	1	0	1	0	0	0	0	0	0	0	Blank
0	1	1	1	1	1	0	0	0	0	0	0	0	0	Blank
0	1	1	1	1	1	1	0	0	0	0	0	0	0	Blank
1	1	1	X	X	X	X								.

X = Don't Care

* Depends on BCD code previously applied when LE = 0

NOTE: Display is blank for all illegal input codes (BCD > 1001).

Typical Performance Characteristics

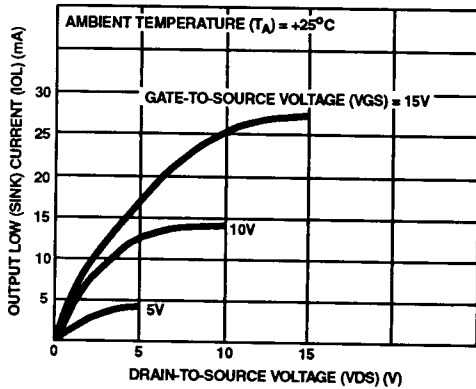

FIGURE 2. TYPICAL OUTPUT LOW (SINK) CURRENT CHARACTERISTICS

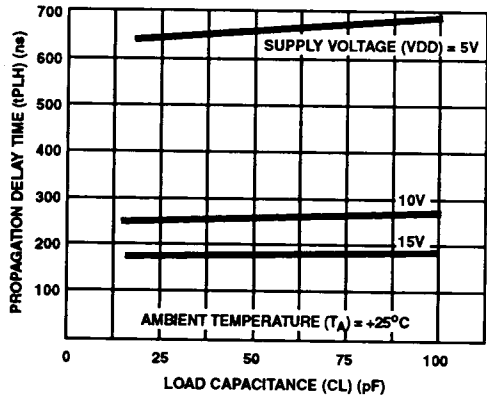

FIGURE 3. TYPICAL DATA-TO-OUTPUT, LOW-TO-HIGH-LEVEL PROPAGATION DELAY TIME AS A FUNCTION OF LOAD CAPACITANCE

Typical Performance Characteristics

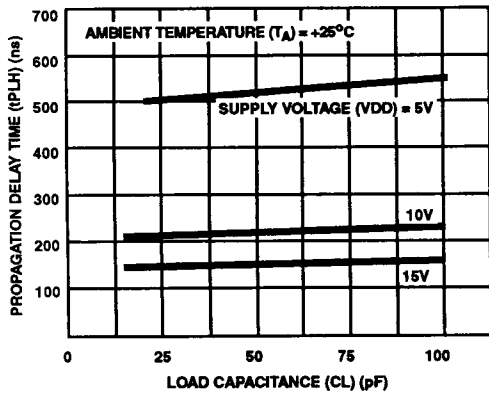

FIGURE 4. TYPICAL DATA-TO-OUTPUT, HIGH-TO-LOW-LEVEL PROPAGATION DELAY TIME AS A FUNCTION OF LOAD CAPACITANCE

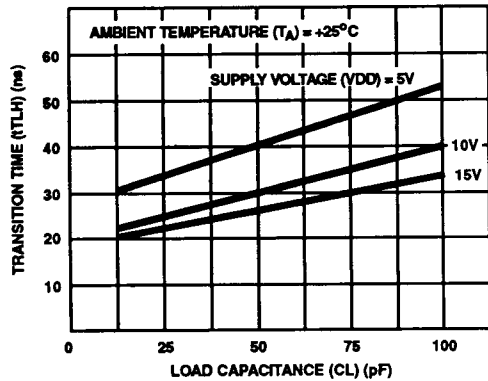

FIGURE 5. TYPICAL LOW-TO-HIGH-LEVEL TRANSITION TIME AS A FUNCTION OF LOAD CAPACITANCE

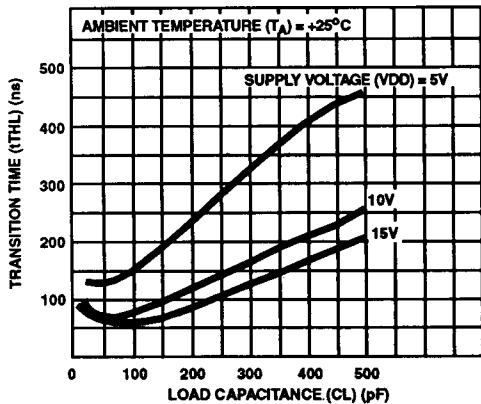

FIGURE 6. TYPICAL HIGH-TO-LOW TRANSITION TIME AS A FUNCTION OF LOAD CAPACITANCE

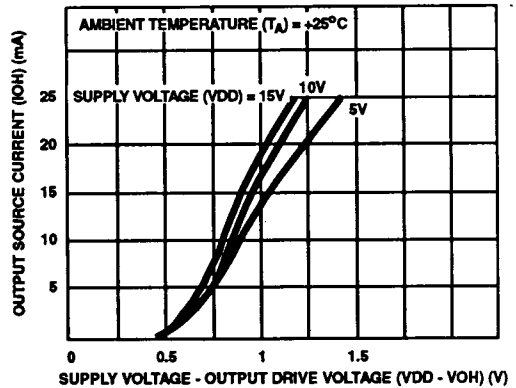

FIGURE 7. TYPICAL VOLTAGE DROP (VDD TO OUTPUT) vs OUTPUT SOURCE CURRENT AS A FUNCTION OF SUPPLY

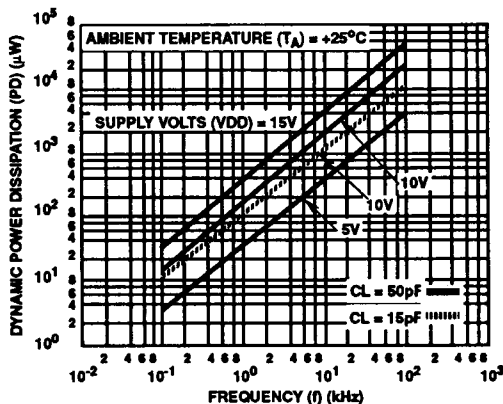
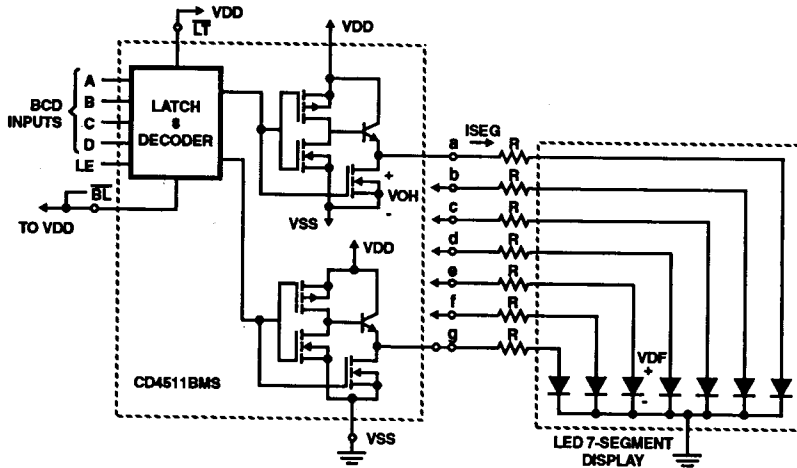

FIGURE 8. TYPICAL DYNAMIC POWER DISSIPATION CHARACTERISTICS

Applications Interfacing with Various Displays



DUTY CYCLE = 100%
 ISEG = IDIODEAVG. = 20mA AT LUMINOUS INTENSITY/SEGMENT = 250 μ cd

$$R = \frac{V_{OH} - V_{DF}}{I_{SEG}}$$

FIGURE 9. DRIVING COMMON CATHODE 7-SEGMENT LED DISPLAYS (EXAMPLE HEWLET-PACKARD 5082-7740)

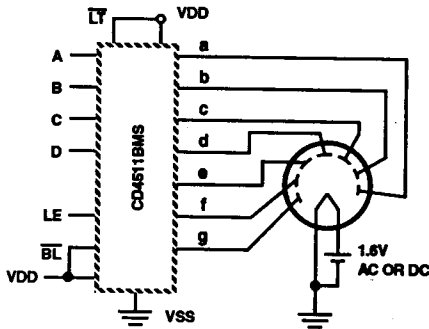

A MEDIUM BRIGHTNESS INTENSITY DISPLAY CAN BE OBTAINED WITH LOW VOLTAGE FLOURESCENT DISPLAYS SUCH AS THE TUNG-SOL DIGIVAC S/G* SERIES

* Trademark Tung-Sol Division Wagner Electric Co.

FIGURE 10. DRIVING LOW VOLTAGE FLOURESCENT DISPLAYS

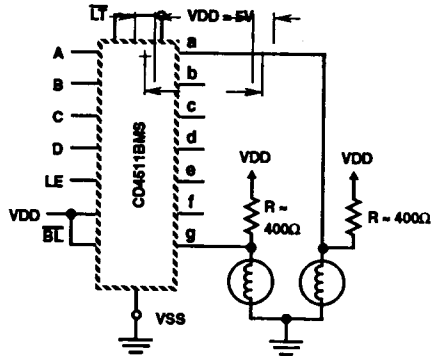

2 OF 7 SEGMENTS SHOWN CONNECTED

RESISTORS R FROM VDD TO EACH 7-SEGMENT DRIVER OUTPUT ARE CHOSEN TO KEEP ALL NUMITRON SEGMENTS SLIGHTLY ON AND WARM

FIGURE 11. DRIVING INCANDESCENT DISPLAYS (RCA NUMITRON DR2000 SERIES DISPLAYS)

Applications Interfacing with Various Displays (Continued)

MULTIPLEXING SCHEME SHOWING 2 OF 7 SEGMENTS CONNECTED

TRANSISTORS T1 - T4 (2N3053 OR 2N2102) HAVE IC MAX. RATING > 7 x ISEG

DUTY CYCLE = 25%

ISEG = (IDIOEAVG) x 4

$$R = \frac{(VOH - VDF - VCE)}{ISEG}$$

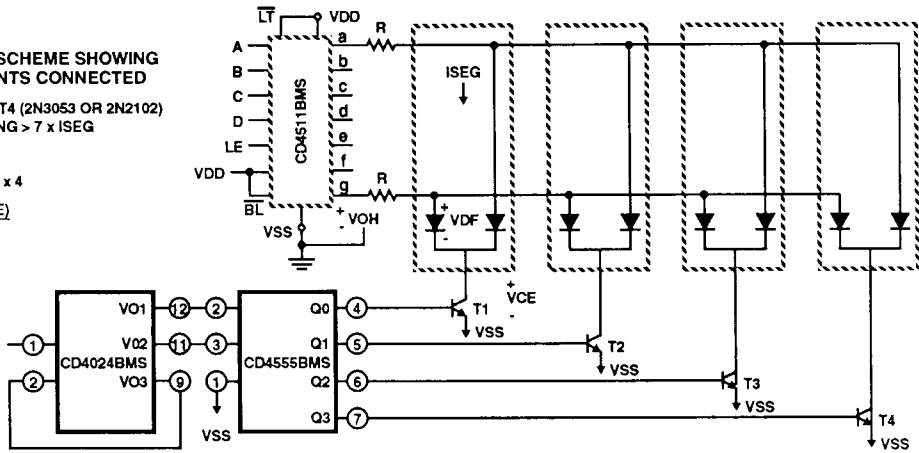

FIGURE 12. MULTIPLEXING WITH COMMON CATHODE 7-SEGMENT LED DISPLAYS (EXAMPLE HEWLETT-PACKARD 5082-7404 4 CHARACTER DISPLAY OR 4 DISCRETE MONOSANTO MAN 3 DISPLAYS)

Waveforms

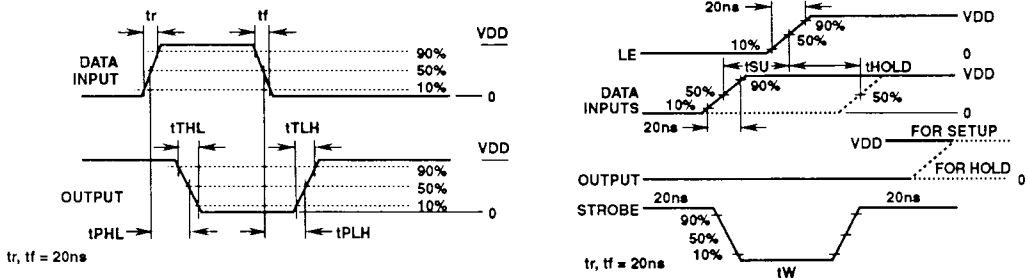
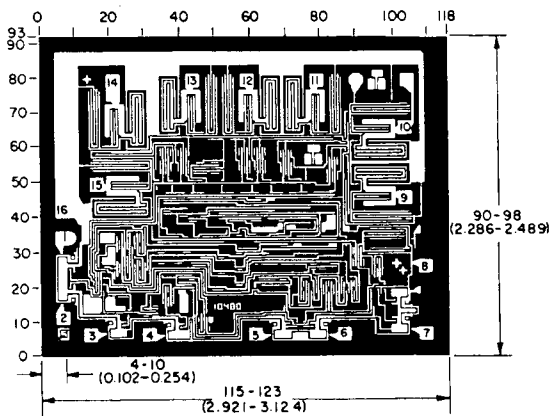

FIGURE 13. DYNAMIC WAVEFORMS

Chip Dimensions and Pad Layout



Dimensions in parenthesis are in millimeters and are derived from the basic inch dimensions as indicated. Grid graduations are in mils (10^{-3} inch).

- METALLIZATION:** Thickness: $11\text{k}\text{\AA} - 14\text{k}\text{\AA}$, AL.
- PASSIVATION:** $10.4\text{k}\text{\AA} - 15.6\text{k}\text{\AA}$, Silane
- BOND PADS:** 0.004 inches X 0.004 inches MIN
- DIE THICKNESS:** 0.0198 inches - 0.0218 inches