

256 Command Infrared Remote Control Transmitter

FEATURES

- 256 Commands (possibly 32 commands by 3 bit address)
- Low Standby current (<math><20\mu\text{A}</math>)
- Low duty cycle (<math><8\%</math>)
- 6/9 Volt battery operation
- Simple RC defined on chip Oscillator
- 22 pin DIL package
- Single shot or continuous operation
- Transmission format ensuring error free reception

DESCRIPTION

The AY-3-8470 transmitter together with AY-3-8475 receiver, an infrared link and an amplifier, forms a complete remote control system. Control of standard functions of radios and televisions is possible together with TV games, Teletext and Viewdata applications.

Complementary MOS technology for this device allows low voltage battery operation with a very low standby current.

256 output commands are possible which can be simply activated by a standard 8 x 4 keypad together with 3 shift inputs.

A non critical, simple RC oscillator is used to fix the transmitter frequency.

PIN CONFIGURATION 22 PIN DUAL IN LINE

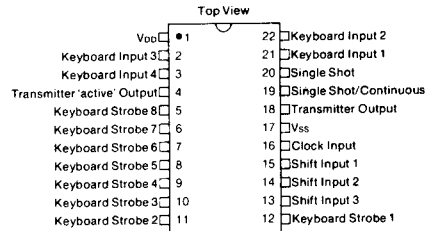

BLOCK DIAGRAM

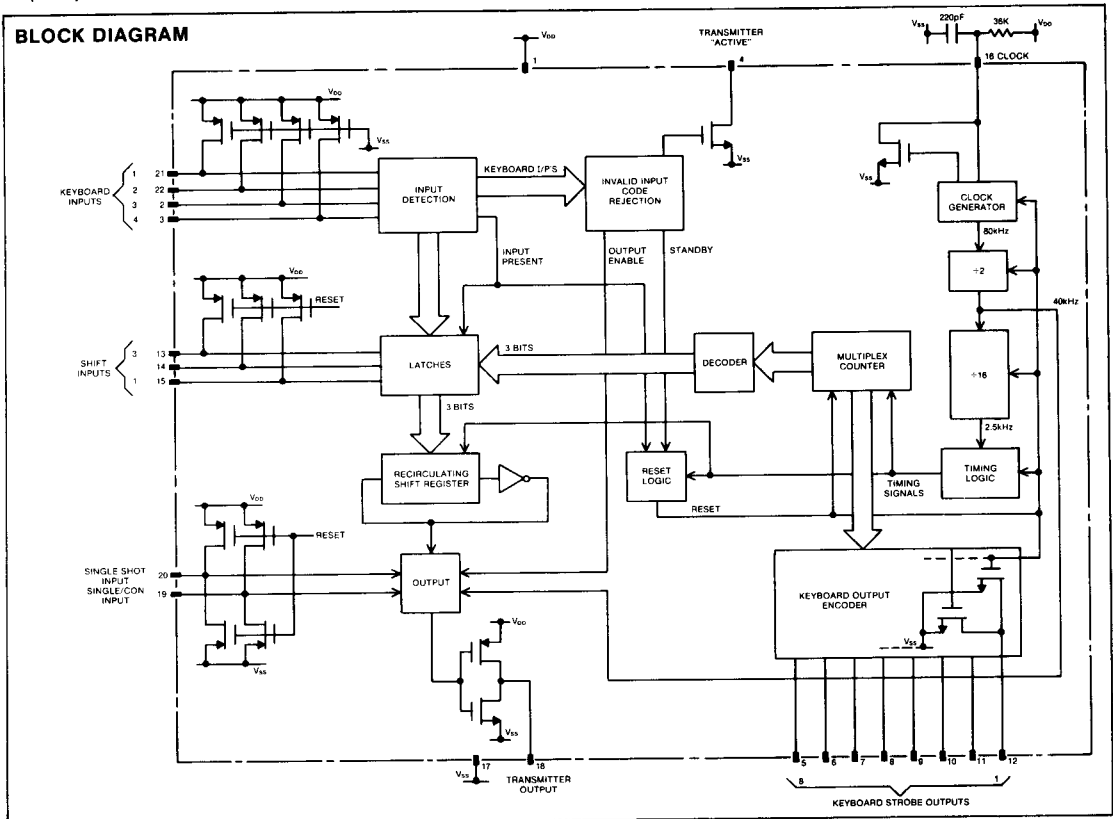

ELECTRICAL CHARACTERISTICS

Maximum Ratings*

Voltage on any Pin with Respect to V_{SS} -0.3 to +12V
 Ambient Operating Temperature 0°C to 70°C
 Storage Temperature -65°C to +150°C

Standard Conditions (unless otherwise stated)

V_{SS} = 0 Volts
 V_{DD} = +5.5 to +10 Volts
 Temperature = 0° C to 70° C

* Exceeding these ratings could cause permanent damage to the device. This is a stress rating only and functional operation of this device at these conditions is not implied—operating ranges are specified in Standard Conditions. Exposure to absolute maximum rating conditions for extended periods may affect device reliability. Data labeled "typical" is presented for design guidance only and is not guaranteed.

Characteristic	Sym	Min	Typ	Max	Units	Conditions
Clock Frequency (16)	F _C	60	80	100	kHz	V _{DD} = 5.5 to 10.0 V, T = 25°C C _C and R _C at typical values and C _C R _C tolerance ±5%
Resistor to V _{DD}	R _C	12	39	100	KΩ	
Capacitor to V _{SS}	C _C	—	220	—	pF	
Leakage to V _{SS}	—	—	—	2	μA	Clock "OFF" in 'standby' and V _{OUT} = V _{DD} = 10.0 Volts
Shift (13, 14, 15) , Keyboard (2, 3, 21, 22) and Single Shot (19, 20) Input Thresholds						
Low Level	V _{IL}	V _{SS}	—	1.5	V	V _{DD} = 5.5 Volts
	V _{IL}	V _{SS}	—	2.5	V	V _{DD} = 10.0 Volts
High Level	V _{IH}	V _{DD} -1.5	—	V _{DD}	V	V _{DD} = 5.5 Volts
	V _{IH}	V _{DD} -2.5	—	V _{DD}	V	V _{DD} = 10.0 Volts
Pull Up to V_{DD}						
Low Level Source	I _{IL}	—	—	50	μA	V _{IN} = 1.5 Volts, V _{DD} = 5.5 Volts
	I _{IL}	—	—	200	μA	V _{IN} = 2.5 Volts, V _{DD} = 10.0 Volts
High Level	—	V _{DD} -1.5	—	—	V	I _{IH} = 2μA source
Transmitter Output (18)						
Low Level	V _{OL}	—	—	0.5	V	I _{OL} = 75μA sink
High Level	V _{OH}	V _{DD} -0.5	—	—	V	I _{OH} = 1.0mA source
Keyboard Strobe Outputs (5-12)						
Low Level	V _{OL}	—	—	0.5	V	I _{OL} = 150μA sink, V _{DD} = 5.5 Volts
	V _{OL}	—	—	1.5	V	I _{OL} = 600μA sink, V _{DD} = 10.00 Volts
Off Leakage to V _{SS}	—	—	—	2.0	μA	V _{OUT} = V _{DD} = 10.0 Volts
Transmitter 'Active' Output (4)						
Low Level	V _{OL}	—	—	1.5	V	I _{OL} = 1.5mA sink
Off Leakage to V _{SS}	—	—	—	2	μA	V _{OUT} = V _{DD} = 10.0 Volts
Single Shot (20), Single Shot/Continuous (19) Inputs						
Standby Pull Down to V _{SS}	V _{OL}	—	—	0.5	V	I _{OL} = 10μA sink
Supply Current V _{DD} (1)	I _{DD}	—	1	3	mA	V _{DD} = 10.0 Volts
Standby Current V _{DD} (1)	I _{DD}	—	5	20	μA	V _{DD} = 9.0 Volts, T = 25° C

- NOTES: 1. Pull Ups are configured with Enhancement FET's.
 2. Current from the device is defined as 'source' current, current into the device is 'sink' current.

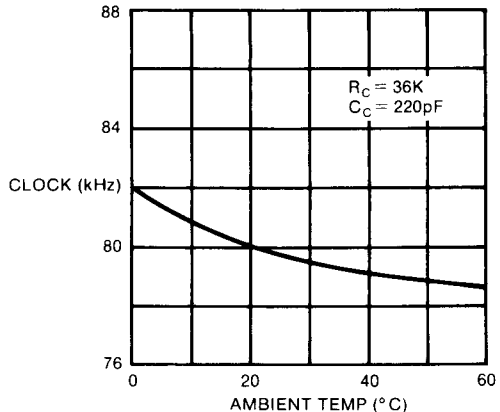
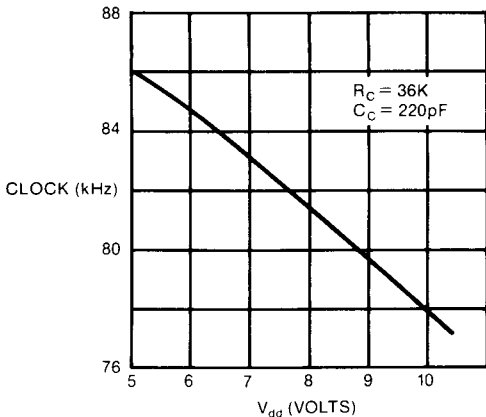

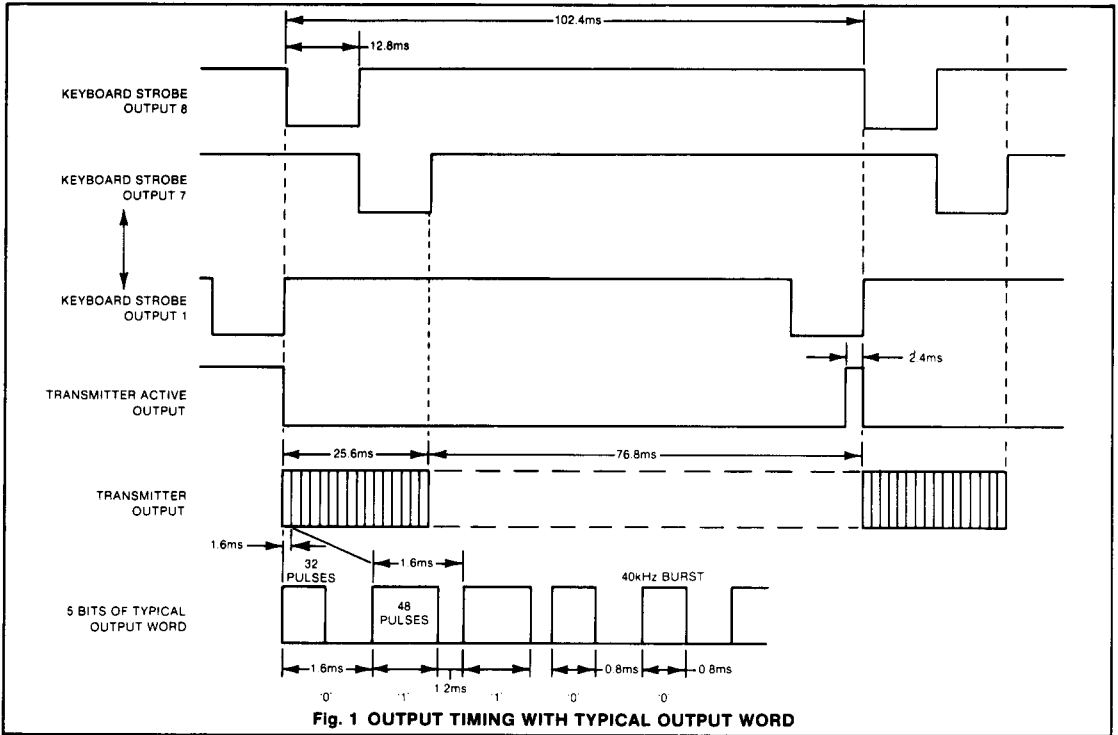

24	16	8	0	12	KB STROBE O/P 1
25	17	9	1	11	KB STROBE O/P 2
26	18	10	2	10	KB STROBE O/P 3
27	19	11	3	9	KB STROBE O/P 4
28	20	12	4	8	KB STROBE O/P 5
29	21	13	5	7	KB STROBE O/P 6
30	22	14	6	6	KB STROBE O/P 7
31	23	15	7	5	KB STROBE O/P 8
				21	KBI/P 1
				22	KBI/P 2
				2	KBI/P 3
				3	KBI/P 4

Decimal equivalent of binary output code for contact closure at X.

Fig. 2 MATRIX FORMAT

Shift Input 3 (13)	Shift Input 2 (14)	Shift Input 1 (15)	Output Codes
H	H	H	0 to 31
H	H	L	32 to 63
H	L	H	64 to 95
H	L	L	96 to 127
L	H	H	128 to 159
L	H	L	160 to 191
L	L	H	192 to 223
L	L	L	224 to 255

H signifies High Level
L signifies Low Level

Fig. 3 SIGNIFICANCE OF SHIFT INPUTS

Single Shot Input (20)	Single Shot/Continuous (19)	Mode
H	H	Continuous on all Codes.
L	'Don't care'	Single Shot on all Codes.
H	L	Codes 0 to 127 continuous. Codes 128 to 255 Single shot.

NOTE: During Standby Single Shot Input (20) and Single Shot/Continuous Input (19) are pulled low internally.

Fig. 4 SINGLE SHOT MODES OF OPERATION

GENERAL INSTRUMENT	AY-3-8470
--------------------	-----------

Code Allocations

Transmitted Code*	Receiver Functions (Using the AY-3-8475)
0	Program 1
1	Program 2
2	Program 3
3	Program 4
4	Program 5
5	Program 6
6	Program 7
7	Program 8
8	Program 9
9	Program 10
10	Program 11
11	Program 12
12	Program 13
13	Program 14
14	Program 15
15	Program 16
16	Volume Increase

Transmitted Code*	Receiver Functions (Using the AY-3-8475)
17	Volume Decrease
18	Color Increase
19	Color Decrease
20	Brightness Increase
21	Brightness Decrease
22	Spare Increase
23	Spare Decrease
24	Normalize
25	Mute
26	ON/OFF to OFF
27	Spare 1 On
28	Spare 1 Off
29	Spare 1 Toggle
30	Spare 2 On
31	Spare 2 Off
32-47	Program 17-32
48-255	Spare

* Decimal equivalent of 8 bit binary word listed for convenience.

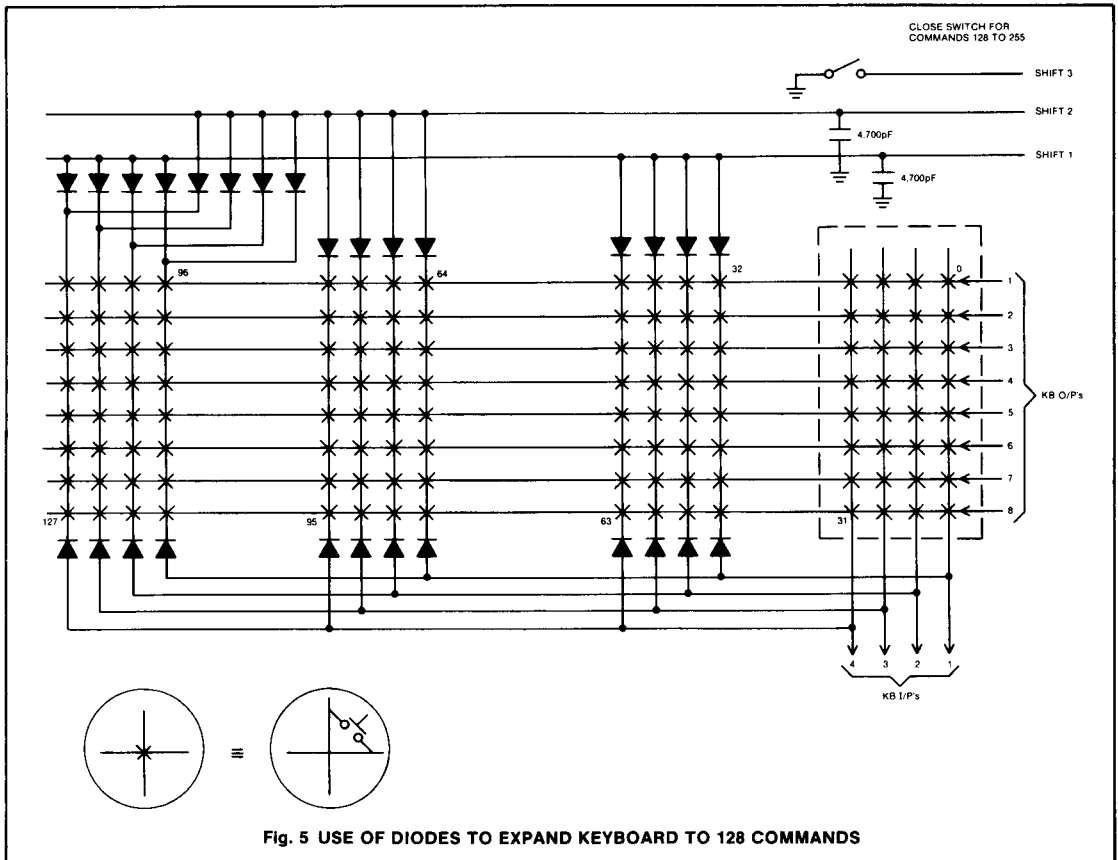

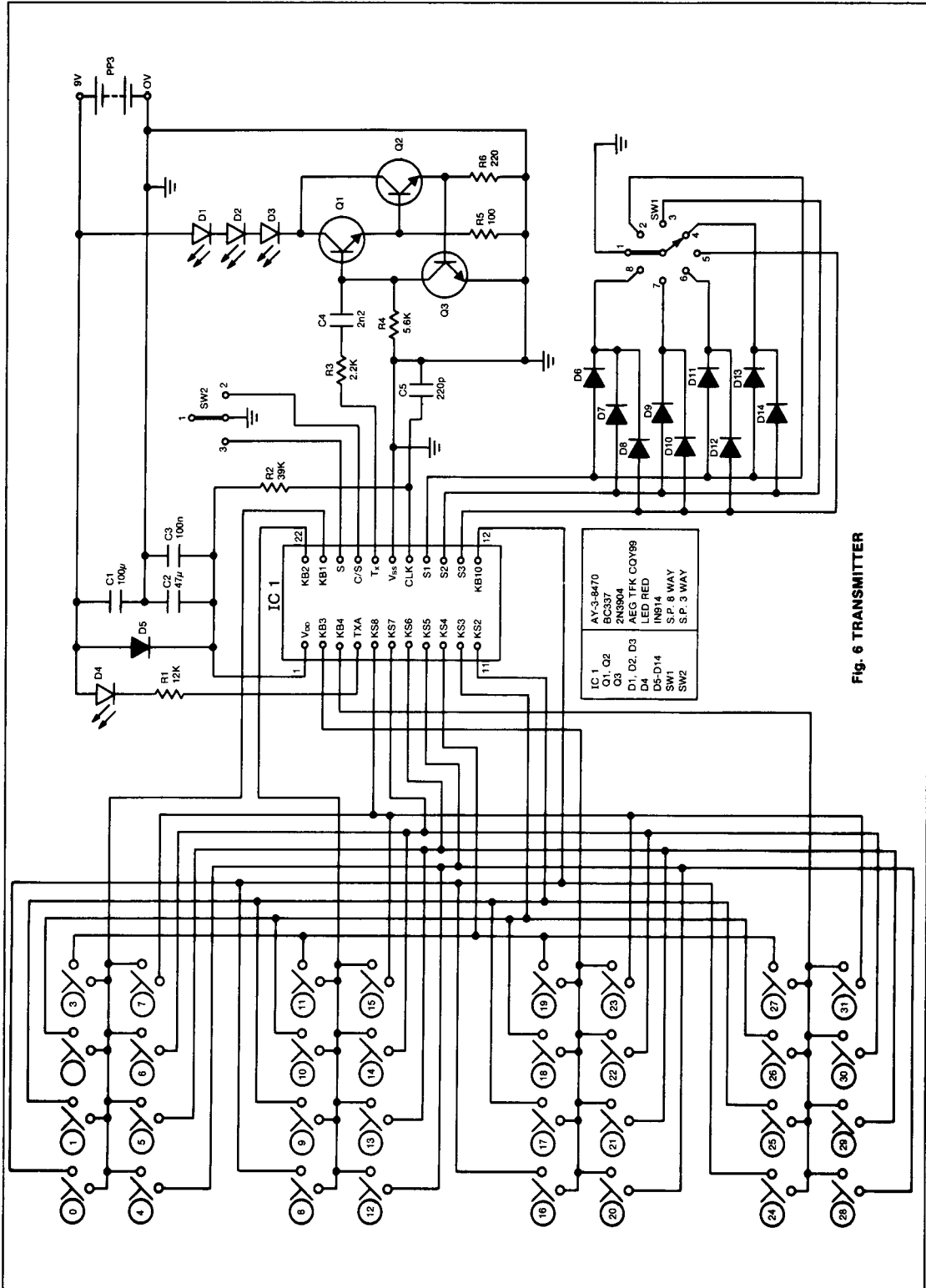

Fig. 6 TRANSMITTER

IC 1	AY-3-8470
Q1, Q2	BC337
Q3	2N3904
D1, D2, D3	AEG TFK COV99
D4	LED RED
D5-D14	INB14
SW1	S.P. 3 WAY
SW2	S.P. 3 WAY