

High Performance Isolated Collector Silicon Bipolar Transistor

Technical Data

HBFP-0405

Features

- Ideal for High Gain, Low Current Applications
- Typical Performance at 1.8 GHz
 - Associated Gain of 18 dB and Noise Figure of 1.2 dB at 2 V and 2 mA
 - P_{1dB} of 5 dBm at 2 V and 5 mA
- Miniature 4-lead SC-70 (SOT-343) Plastic Package
- Transition Frequency $f_T = 25$ GHz

Applications

- LNA, Oscillator, Driver Amplifier, Buffer Amplifier, and Down Converter for *Cellular and PCS Handsets and Cordless Telephones*
- Oscillator for *TV Delivery and TVRO Systems up to 12 GHz*

Surface Mount Plastic Package/SOT-343 (SC-70) Outline 4T

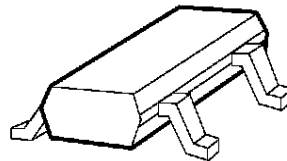

Pin Configuration

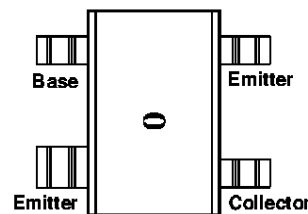

Note:
Package marking provides orientation and identification.

Description

Hewlett Packard's HBFP-0405 is a high performance isolated collector silicon bipolar junction transistor housed in a 4-lead SC-70 (SOT-343) surface mount plastic package.

HBFP-0405 provides an associated gain of 18 dB, noise figure of 1.2 dB, and P_{1dB} of 5 dBm at 1.8 GHz. Because of high gain and low current characteristics, HBFP-0405 is ideal for *cellular/PCS* as well as for *C-Band and Ku-Band* applications.

This product is based on a 25 GHz transition frequency fabrication process, which enables the products to be used for high performance, low noise applications at 900 MHz, 1.9 GHz, 2.4 GHz, and beyond.

HBFP-0405 Absolute Maximum Ratings

Symbol	Parameter	Units	Absolute Maximum ⁽¹⁾
V_{EBO}	Emitter-Base Voltage	V	1.5
V_{CBO}	Collector-Base Voltage	V	15.0
V_{CEO}	Collector-Emitter Voltage	V	4.5
I_C	Collector Current	mA	12
P_T	Power Dissipation ⁽²⁾	mW	54
T_j	Junction Temperature	°C	150
T_{STG}	Storage Temperature	°C	-65 to 150

Thermal Resistance:

$$\theta_{jc} = 550^\circ\text{C/W}$$

Notes:

1. Permanent damage may occur if any of these limits are exceeded.
2. P_T limited by maximum ratings.

Electrical Specifications, $T_C = 25^\circ\text{C}$

Symbol	Parameters and Test Conditions	Units	Min.	Typ.	Max.
DC Characteristics					
BV_{CEO}	Collector-Emitter Breakdown Voltage	$I_C = 1 \text{ mA}$, open base	V	4.5	
I_{CBO}	Collector-Cutoff Current	$V_{CB} = 5 \text{ V}$, $I_E = 0$	nA		150
I_{EBO}	Emitter-Base Cutoff Current	$V_{EB} = 1.5 \text{ V}$, $I_C = 0$	μA		15
h_{FE}	DC Current Gain	$V_{CE} = 2 \text{ V}$, $I_C = 2 \text{ mA}$	—	50	80
RF Characteristics					
F_{MIN}	Minimum Noise Figure	$I_C = 2 \text{ mA}$, $V_{CE} = 2 \text{ V}$, $f = 1.8 \text{ GHz}$	dB		1.2
G_a	Associated Gain	$I_C = 2 \text{ mA}$, $V_{CE} = 2 \text{ V}$, $f = 1.8 \text{ GHz}$	dB	16.5	18
$ S_{21} ^2$	Insertion Power Gain	$I_C = 5 \text{ mA}$, $V_{CE} = 2 \text{ V}$, $f = 1.8 \text{ GHz}$	dB		17
P_{1dB}	Power Output @ 1 dB Compression Point	$I_C = 5 \text{ mA}$, $V_{CE} = 2 \text{ V}$, $f = 1.8 \text{ GHz}$	dBm		5

HBFP-0405 Typical Scattering Parameters,

$V_{CE} = 2 \text{ V}$, $I_C = 2 \text{ mA}$, $T_C = 25^\circ\text{C}$

Freq. GHz	S_{11}		S_{21}			S_{12}			S_{22}	
	Mag	Ang	dB	Mag	Ang	dB	Mag	Ang	Mag	Ang
0.1	0.910	-4.2	16.5	6.665	176.2	-49.6	0.003	88.5	0.995	-2.2
0.5	0.889	-21.2	16.3	6.496	160.6	-35.6	0.017	80.5	0.982	-10.5
0.9	0.855	-37.6	15.7	6.101	146.0	-30.4	0.030	71.9	0.951	-18.8
1.0	0.841	-41.4	15.6	5.993	142.5	-29.5	0.033	69.6	0.937	-20.9
1.5	0.774	-60.9	14.8	5.484	125.9	-26.4	0.048	57.5	0.880	-30.8
1.8	0.730	-72.0	14.3	5.164	116.8	-25.1	0.055	50.6	0.843	-36.4
2.0	0.701	-79.4	13.9	4.964	110.9	-24.5	0.059	46.4	0.817	-39.8
2.5	0.634	-96.0	13.0	4.450	97.0	-23.4	0.068	37.0	0.758	-47.8
3.0	0.570	-112.3	12.0	3.996	84.7	-22.7	0.073	28.7	0.708	-54.9
3.5	0.521	-127.0	11.2	3.620	73.4	-22.3	0.077	21.7	0.669	-60.9
4.0	0.477	-141.2	10.4	3.320	62.9	-21.9	0.080	15.6	0.634	-66.4
4.5	0.443	-154.7	9.7	3.047	53.6	-21.8	0.082	10.7	0.613	-71.5
5.0	0.412	-168.7	9.0	2.829	44.2	-21.5	0.084	6.0	0.591	-76.4
5.5	0.386	177.1	8.5	2.646	34.9	-21.3	0.087	1.6	0.571	-80.8
6.0	0.372	162.2	7.9	2.493	25.6	-21.0	0.089	-2.1	0.550	-86.1
6.5	0.369	147.7	7.5	2.371	16.8	-20.7	0.093	-7.0	0.525	-90.5
7.0	0.366	130.7	7.1	2.258	8.1	-20.4	0.096	-10.7	0.496	-95.2
7.5	0.370	116.2	6.6	2.141	-1.3	-20.0	0.100	-14.7	0.471	-100.2
8.0	0.387	102.9	6.2	2.042	-9.8	-19.8	0.103	-19.2	0.444	-106.7
8.5	0.405	91.4	5.7	1.937	-18.3	-19.5	0.105	-23.6	0.425	-113.9
9.0	0.421	80.9	5.3	1.834	-26.6	-19.3	0.109	-27.9	0.411	-121.3
9.5	0.437	70.5	4.9	1.753	-35.2	-19.0	0.112	-32.4	0.398	-127.7
10.0	0.454	60.3	4.4	1.669	-43.7	-18.8	0.115	-37.0	0.385	-133.5

HBFP-0405 Noise Parameters: $V_{CE} = 2 \text{ V}$, $I_C = 2 \text{ mA}$

Freq. GHz	F_{\min} dB	Γ_{opt}		R_N Ω	G_a dB
		Mag	Ang		
0.9	1.07	0.569	9.3	20.9	23.46
1.0	1.09	0.558	11.6	20.6	22.67
1.5	1.19	0.504	22.0	19.2	19.64
1.8	1.25	0.474	28.7	18.5	18.28
2.0	1.29	0.456	33.6	18.0	17.50
2.5	1.39	0.423	48.2	16.6	15.91
3.0	1.48	0.391	59.3	15.6	14.39
3.5	1.57	0.352	72.1	14.2	13.29
4.0	1.70	0.318	83.1	13.0	12.29
4.5	1.78	0.290	93.9	12.1	11.43
5.0	1.87	0.257	107.3	10.9	10.71
5.5	2.00	0.215	118.3	10.5	10.03
6.0	2.10	0.179	133.7	10.4	9.47
6.5	2.18	0.157	153.1	10.2	8.97
7.0	2.29	0.125	-179.2	11.0	8.50
7.5	2.35	0.116	-154.8	12.0	7.98
8.0	2.50	0.140	-123.4	13.7	7.63
8.5	2.65	0.163	-104.1	15.9	7.21
9.0	2.76	0.191	-89.2	18.6	6.81
9.5	2.93	0.226	-73.4	22.3	6.51
10.0	2.94	0.254	-61.4	26.3	6.16

S and noise parameters are measured on a microstrip line made on 0.025 inch thick alumina carrier. The input reference plane is at the end of the base lead, the output reference plane is at the end of the collector lead. S and noise parameters include the effect of four plated through via holes connecting emitter landing pads on the top of test carrier to the microstrip ground plane on the bottom side of the carrier. Two 0.020 inch diameter via holes are placed within 0.010 inch from each emitter lead contact point, one via on each side of that point.

HBFP-0405 Typical Scattering Parameters,

$V_{CE} = 2\text{ V}$, $I_C = 5\text{ mA}$, $T_C = 25^\circ\text{C}$

Freq. GHz	S_{11}		S_{21}			S_{12}			S_{22}	
	Mag	Ang	dB	Mag	Ang	dB	Mag	Ang	Mag	Ang
0.1	0.819	-6.2	22.0	12.630	174.5	-50.2	0.003	87.8	0.990	-2.8
0.5	0.775	-30.3	21.5	11.912	153.5	-36.2	0.016	77.1	0.959	-13.4
0.9	0.704	-52.4	20.6	10.664	134.9	-31.5	0.027	67.3	0.897	-23.3
1.0	0.681	-57.2	20.3	10.308	130.7	-30.8	0.029	64.9	0.875	-25.5
1.5	0.585	-81.5	18.8	8.689	111.9	-28.1	0.039	54.0	0.783	-35.2
1.8	0.531	-94.5	17.9	7.817	102.5	-27.2	0.044	49.0	0.733	-40.1
2.0	0.500	-102.7	17.3	7.306	96.7	-26.6	0.047	46.0	0.703	-43.0
2.5	0.440	-121.3	15.9	6.208	83.7	-25.6	0.053	39.9	0.641	-49.4
3.0	0.392	-138.9	14.6	5.362	72.4	-24.8	0.057	34.6	0.597	-55.0
3.5	0.360	-154.1	13.5	4.716	62.3	-24.2	0.061	30.4	0.566	-59.7
4.0	0.334	-168.9	12.5	4.214	52.9	-23.6	0.066	26.5	0.541	-64.2
4.5	0.315	177.0	11.6	3.814	44.3	-23.1	0.070	23.0	0.528	-68.6
5.0	0.302	162.5	10.9	3.491	35.7	-22.5	0.075	19.0	0.513	-73.0
5.5	0.295	148.1	10.2	3.229	27.4	-22.0	0.079	15.1	0.499	-77.0
6.0	0.301	133.7	9.6	3.010	19.0	-21.5	0.084	11.1	0.484	-82.0
6.5	0.311	120.4	9.0	2.827	10.8	-21.0	0.089	6.4	0.463	-86.1
7.0	0.327	105.9	8.5	2.668	2.6	-20.5	0.095	2.1	0.439	-90.5
7.5	0.346	94.0	8.0	2.520	-5.8	-20.0	0.101	-3.0	0.414	-95.4
8.0	0.369	83.4	7.6	2.389	-13.8	-19.5	0.106	-7.7	0.389	-101.6
8.5	0.392	74.1	7.1	2.261	-21.9	-19.1	0.110	-12.8	0.370	-108.5
9.0	0.410	65.6	6.6	2.141	-29.9	-18.7	0.116	-18.0	0.357	-115.8
9.5	0.428	56.9	6.2	2.038	-38.0	-18.4	0.120	-23.1	0.345	-122.3
10.0	0.446	48.2	5.7	1.937	-46.0	-18.1	0.124	-28.5	0.334	-127.9

HBFP-0405 Noise Parameters: $V_{CE} = 2\text{ V}$, $I_C = 5\text{ mA}$

Freq. GHz	F_{min} dB	Γ_{opt}		R_N Ω	G_a dB
		Mag	Ang		
0.9	1.36	0.386	2.8	17.0	25.59
1.0	1.38	0.375	5.0	16.8	24.76
1.5	1.46	0.333	17.7	16.2	21.56
1.8	1.52	0.305	25.5	15.6	20.12
2.0	1.55	0.292	31.9	15.3	19.29
2.5	1.65	0.246	50.0	13.8	17.61
3.0	1.73	0.208	59.9	13.1	16.04
3.5	1.79	0.187	73.6	12.6	14.81
4.0	1.93	0.153	85.6	12.0	13.76
4.5	1.99	0.123	100.2	11.8	12.90
5.0	2.08	0.104	119.5	11.3	12.12
5.5	2.18	0.065	141.5	12.0	11.45
6.0	2.32	0.051	-169.0	12.7	10.87
6.5	2.37	0.068	-129.9	13.5	10.32
7.0	2.48	0.101	-96.3	15.2	9.82
7.5	2.56	0.133	-82.9	17.0	9.33
8.0	2.69	0.177	-71.2	19.7	8.92
8.5	2.85	0.212	-62.8	22.8	8.50
9.0	2.99	0.246	-54.1	26.7	8.10
9.5	3.10	0.282	-46.1	30.9	7.77
10.0	3.12	0.314	-37.3	35.2	7.41

S and noise parameters are measured on a microstrip line made on 0.025 inch thick alumina carrier. The input reference plane is at the end of the base lead, the output reference plane is at the end of the collector lead. S and noise parameters include the effect of four plated through via holes connecting emitter landing pads on the top of test carrier to the microstrip ground plane on the bottom side of the carrier. Two 0.020 inch diameter via holes are placed within 0.010 inch from each emitter lead contact point, one via on each side of that point.

HBFP-0405 Typical Performance

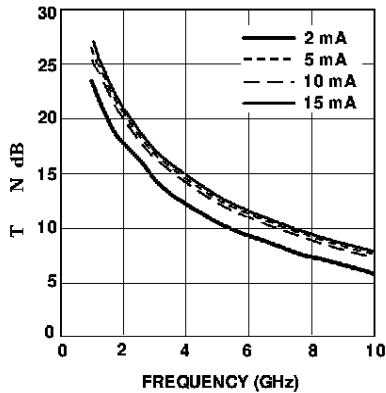

Figure 1. Associated Gain vs. Frequency and Collector Current at 2 V.

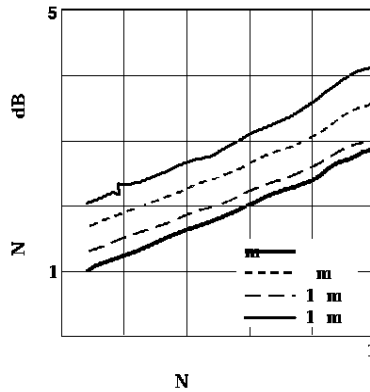

Figure 2. Noise Figure vs. Frequency and Collector Current at $V_{CE} = 2$ V.

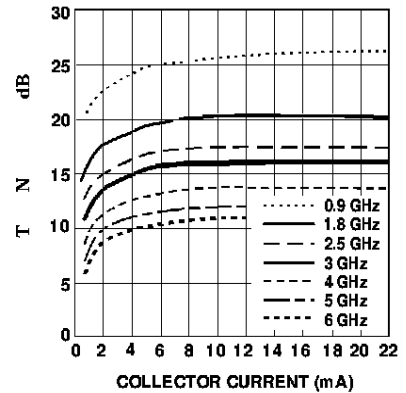

Figure 3. Associated Gain vs. Collector Current and Frequency at 2 V.

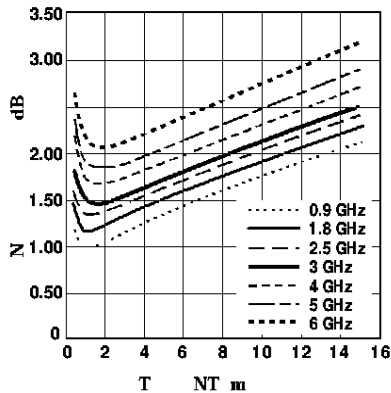

Figure 4. Noise Figure vs. Collector Current and Frequency at 2 V.

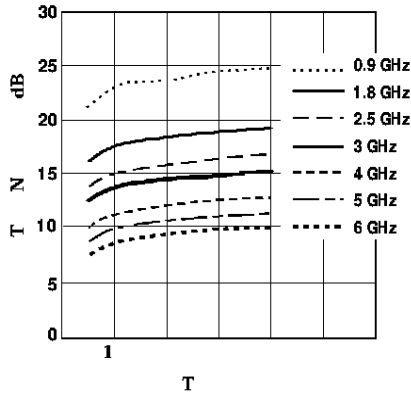

Figure 5. Associated Gain vs. Voltage and Frequency at 2 mA.

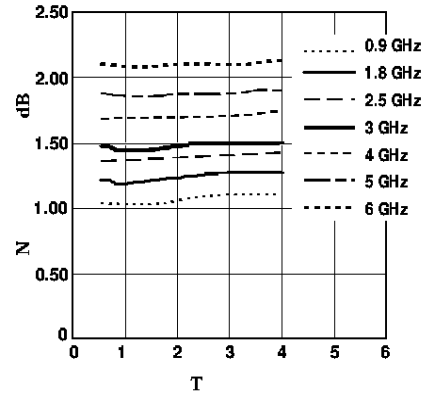
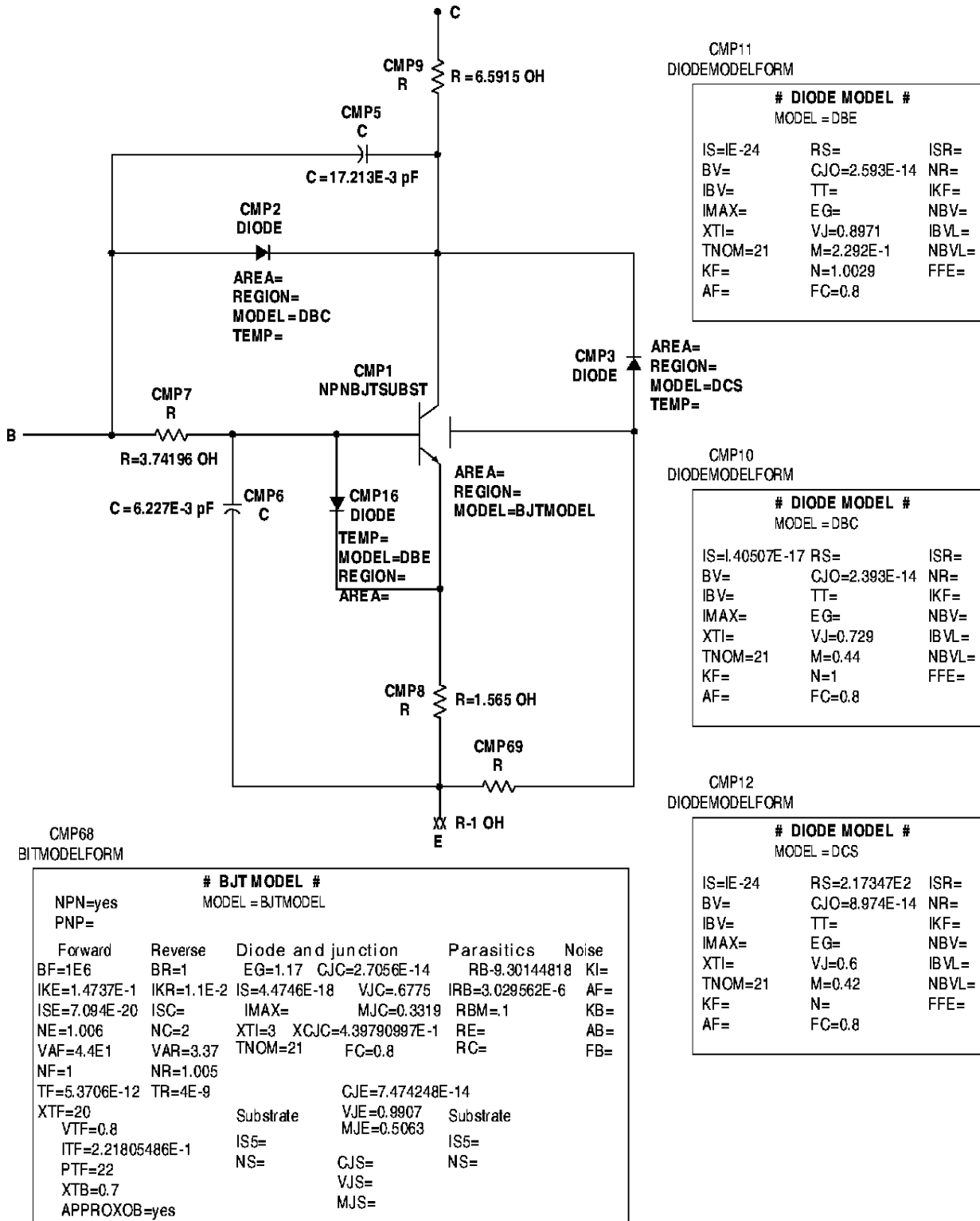

Figure 6. Noise Figure vs. Voltage and Frequency at 2 mA.

HBFP-0405 Die Model and PSPICE Parameters



This model can be used as a design tool. It has been tested on MDS for various specifications. However, for more precise and accurate design, please refer to the measured data in this data sheet.

Note: The value of beta was high (BF=1E6) to compensate for the fact that diode DBE reduces the current going into the base (current flows through DBE). The diodes are necessary to model the non-linear effects.

SOT343 Package Model

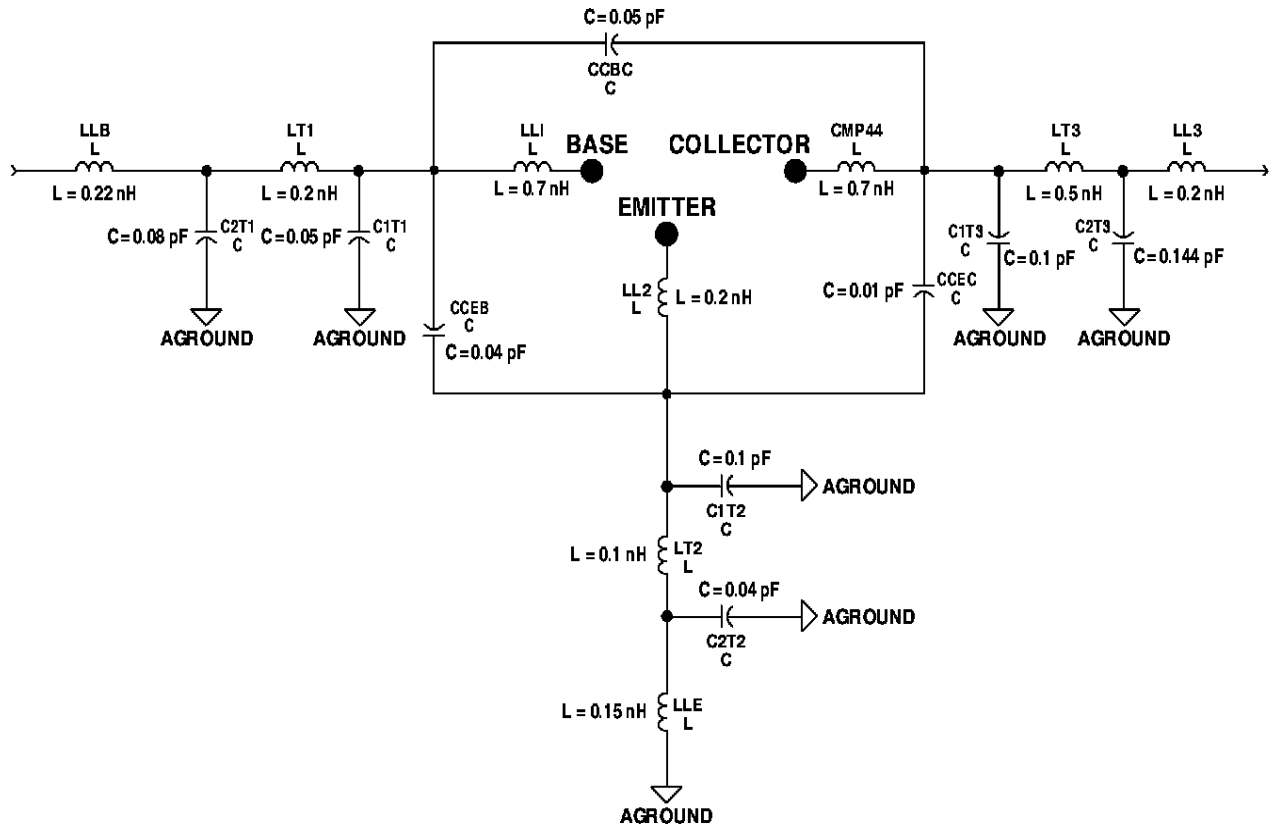

Part Number Ordering Information

Part Number	Devices per Reel	Container
HBFP-0405-TR1	3000	7" Reel
HBFP-0405-TR2	10,000	13" Reel
HBFP-0405-BLK	100	antistatic bag

Package Dimensions SOT-343 (SC-70 4 Lead)

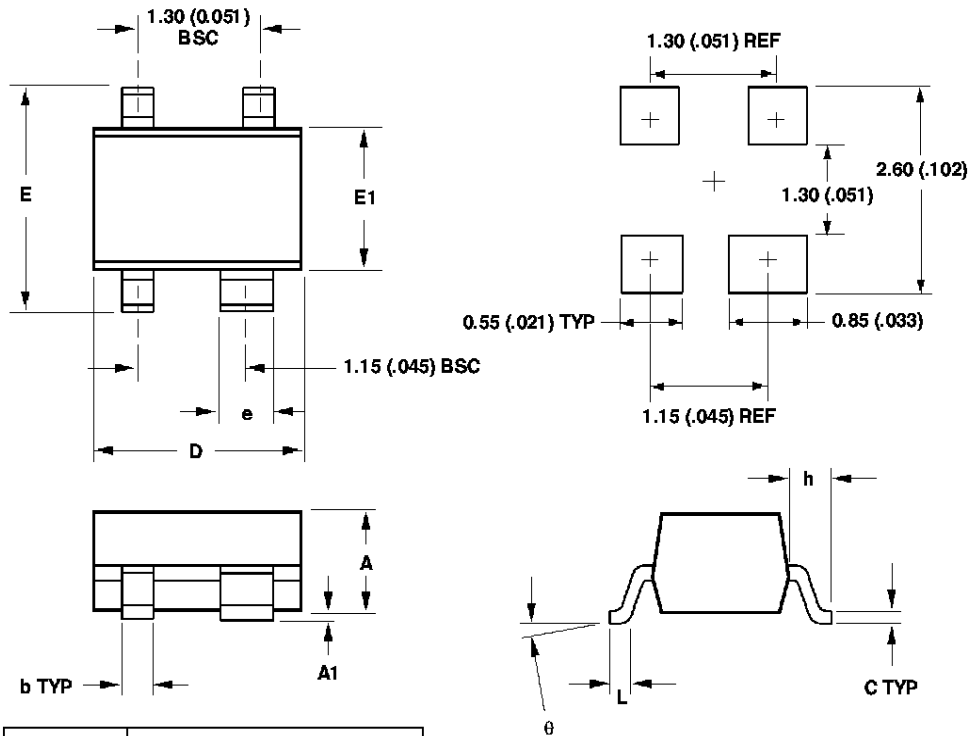

SYMBOL	DIMENSIONS	
	MIN.	MAX.
A	0.80 (0.031)	1.00 (0.039)
A1	0 (0)	0.10 (0.004)
b	0.25 (0.010)	0.35 (0.014)
C	0.10 (0.004)	0.20 (0.008)
D	1.90 (0.075)	2.10 (0.083)
E	2.00 (0.079)	2.20 (0.087)
e	0.55 (0.022)	0.65 (0.025)
h	0.450 TYP (0.018)	
E1	1.15 (0.045)	1.35 (0.053)
L	0.10 (0.004)	0.35 (0.014)
θ	0	10

DIMENSIONS ARE IN MILLIMETERS (INCHES)

Device Orientation

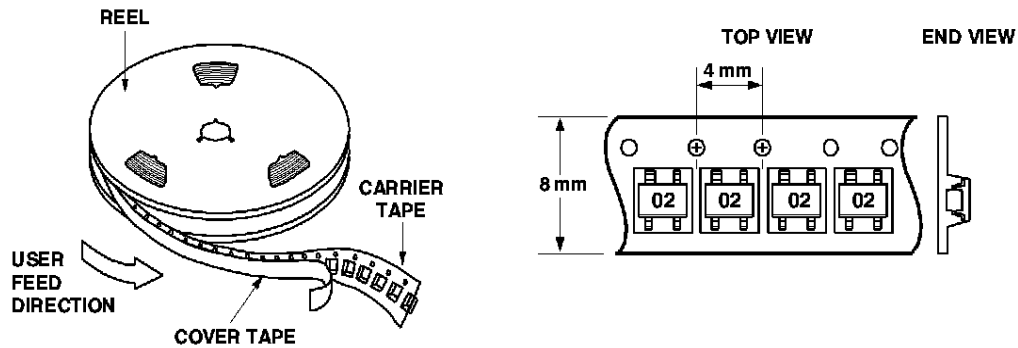

Tape Dimensions For Outline 4T

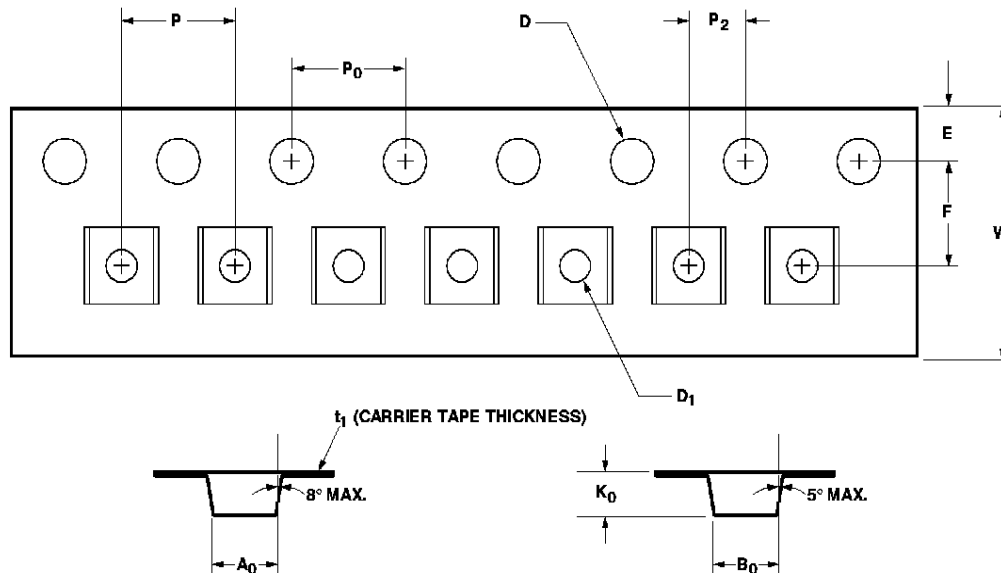

DESCRIPTION		SYMBOL	SIZE (mm)	SIZE (INCHES)
CAVITY	LENGTH	A_0	2.24 ± 0.10	0.088 ± 0.004
	WIDTH	B_0	2.34 ± 0.10	0.092 ± 0.004
	DEPTH	K_0	1.22 ± 0.10	0.048 ± 0.004
	PITCH	P	4.00 ± 0.10	0.157 ± 0.004
	BOTTOM HOLE DIAMETER	D_1	1.00 ± 0.25	0.039 ± 0.010
	PERFORATION	DIAMETER	D	1.55 ± 0.05
	PITCH	P_0	4.00 ± 0.10	0.157 ± 0.004
	POSITION	E	1.75 ± 0.10	0.069 ± 0.004
CARRIER TAPE	WIDTH	W	8.00 ± 0.30	0.315 ± 0.012
	THICKNESS	t_1	0.255 ± 0.013	0.010 ± 0.0005
DISTANCE	CAVITY TO PERFORATION (WIDTH DIRECTION)	F	3.50 ± 0.05	0.138 ± 0.002
	CAVITY TO PERFORATION (LENGTH DIRECTION)	P_2	2.00 ± 0.05	0.079 ± 0.002



www.hp.com/go/rf

For technical assistance or the location of your nearest Hewlett-Packard sales office, distributor or representative call:

Americas/Canada: 1-800-235-0312 or 408-654-8675

Far East/Australasia: Call your local HP sales office.

Japan: (81 3) 3335-8152

Europe: Call your local HP sales office.

Data subject to change.
Copyright © 1998 Hewlett-Packard Co.

Obsoletes 5968-0140E

5968-1689E (8/98)