

# Product Specifications



## 400PTM-CR

TNC Male for CNT-400 braided cable

### CHARACTERISTICS

#### General Specifications

---

Interface	TNC Male
Body Style	Straight

#### Electrical Specifications

---

Operating Frequency Band	0 – 6000 MHz
3rd Order IMD Test Method	Two +43 dBm Carriers
Average Power	580.0 W @ 900 MHz
Cable Impedance	50 ohm
Connector Impedance	50 ohm
dc Test Voltage	1500 V
Inner Contact Resistance	1.50 mOhm
Insertion Loss, typical	0.05 dB
Insulation Resistance, minimum	5000 MOhm
Outer Contact Resistance	0.40 mOhm
Peak Power, maximum	5.00 kW
RF Operating Voltage, maximum (vrms)	500.00 V
Shielding Effectiveness	-90 dB
3rd Order IMD	-75 dBm @ 1800 MHz

# Product Specifications

## Outline Drawing

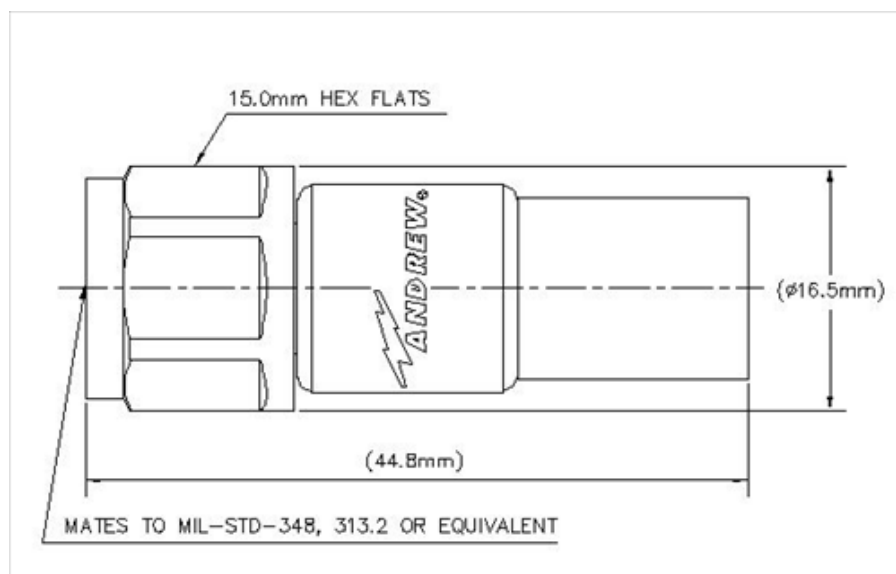

## Mechanical Specifications

Connector Retention Tensile Force	330 N   74 lbf
Connector Retention Torque	1 N-m   1 ft lb
Coupling Nut Proof Torque	1.70 N-m   1.25 ft lb
Coupling Nut Proof Torque Method	IEC 169-17:9.3.6
Coupling Nut Retention Force	445.00 N   100.04 lbf
Coupling Nut Retention Force Method	IEC 169-17:9.3.11
Inner Contact Attachment Method	Solder
Insertion Force	15.00 N   3.37 lbf
Insertion Force Method	IEC 169-17:9.3.5
Interface Durability	500 cycles
Interface Durability Method	IEC 169-17:17
Outer Contact Attachment Method	Crimp
Pressurizable	No

## Dimensions

Nominal Size	0.405 in
Diameter, maximum	16.80 mm   0.66 in
Length	44.76 mm   1.76 in
Weight	35.00 g   0.08 lb
Width	16.80 mm   0.66 in

## Environmental Specifications

Climatic Sequence Test Method	IEC 60068-1
Corrosion Test Method	IEC 60068-2-11
Damp Heat Steady State Test Method	IEC 60068-2-3
Mechanical Shock Test Method	IEC 60068-2-27

# Product Specifications



Operating Temperature	-55 °C to +85 °C (-67 °F to +185 °F)
Storage Temperature	-65 °C to +125 °C (-85 °F to +257 °F)
Thermal Shock Test Method	IEC 60068-2-14
Vibration Test Method	IEC 60068-2-6

## Standard Conditions

---

Attenuation, Ambient Temperature	20 °C   68 °F
Average Power, Ambient Temperature	40 °C   104 °F
Average Power, Inner Conductor Temperature	100 °C   212 °F

## Return Loss

---

Frequency Band	VSWR	Return Loss (dB)
0–3000 MHz	1.10	31.78
3000–6000 MHz	1.21	25.37

## \* Footnotes

---

Insertion Loss, typical  $0.05 \sqrt{\text{freq (GHz)}}$  (not applicable for elliptical waveguide)