

# IS1622

## OPIC Light Detector for Playback/Recording MD player

### ■ Features

- OPIC light detector for RF signal detection  
(Integrates 6-division PIN photodiode and amplifier IC onto a single chip)
- Low operating voltage design (Operating voltage : 2.7 to 5.5V)
- Sensitivity switching between playback mode and recording mode
- Compact and thin transparent package  
(Package dimensions : 3.7 x 6.1 x 1.5 mm)

### ■ Applications

- Optical pickup for playback/recording MD players

### ■ Absolute Maximum Ratings (Ta=25°C)

| Parameter                       | Symbol            | Rating                  | Unit |
|---------------------------------|-------------------|-------------------------|------|
| Supply voltage                  | V <sub>CC</sub>   | -0.5 to +6.0            | V    |
| Cathode terminal voltage        | V <sub>K</sub>    | -0.5 to +6.0            | V    |
| Mode switching terminal voltage | V <sub>MP/R</sub> | -0.5 to V <sub>CC</sub> | V    |
| *1 Output voltage               | V <sub>O</sub>    | -0.5 to V <sub>CC</sub> | V    |
| *2 Power dissipation            | P                 | 150                     | mW   |
| Operating temperature           | T <sub>opr</sub>  | -20 to +70              | °C   |
| Storage temperature             | T <sub>stg</sub>  | -40 to +85              | °C   |
| *3 Soldering temperature        | T <sub>sol</sub>  | +260                    | °C   |

\*1 Applies to individual terminals of V<sub>A</sub>, V<sub>B</sub>, V<sub>C</sub>, V<sub>D</sub>, I<sub>E</sub> and I<sub>F</sub>.

\*2 To decrease at the rate of 2mW/°C at Ta >= 25°C

\*3 For MAX. 3 seconds in the soldering area

### ■ Outline Dimensions

(Unit : mm)

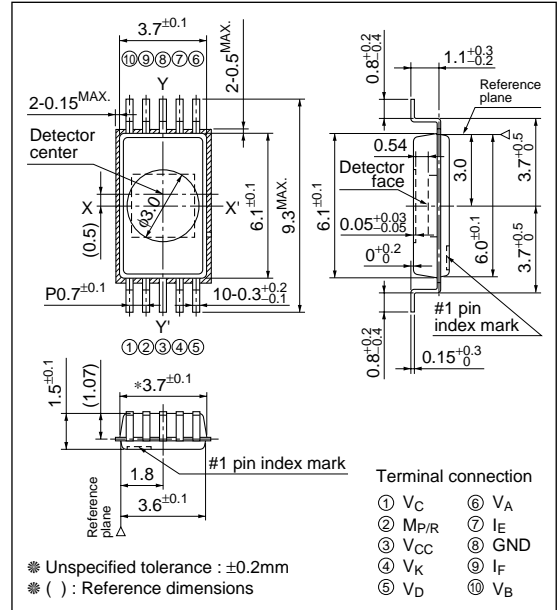

\* "OPIC"(Optical IC) is a trademark of the SHARP Corporation. An OPIC consists of a light-detecting element and signal-processing circuit integrated onto a signal chip.

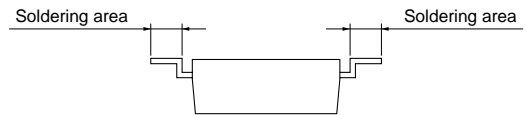

## ■ Recommended Operating Conditions

| Parameter  | Symbol           | MIN. | TYP. | MAX. | Unit |
|--|------------------|------|------|------|------|
| Supply voltage                                   | V <sub>cc1</sub> | 2.7  | 3.0  | 5.5  | V    |
| Cathode terminal voltage                         | V <sub>K</sub>   | 2.7  | 3.0  | 5.5  | V    |
| *4 "H" gain mode incident light quantity range 1 | ΦP1              | 1    | 6    | 17   | μW   |
| *5 "H" gain mode incident light quantity range 2 | ΦP2              | 0.5  | 3    | 6    | μW   |
| *4 "L" gain mode incident light quantity range 1 | ΦR1              | 15   | 50   | 130  | μW   |
| *5 "L" gain mode incident light quantity range 2 | ΦR2              | 7    | 17   | 36   | μW   |

\*4 The incident light quantity range applies to individual photodiodes of A, B, C and D and is specified in the incident light quantity per single photodiode.

\*5 The incident light quantity range applies to individual photodiodes of E and F and is specified in the incident light quantity per single photodiode.

## ■ Electro-optical Characteristics (Current flowing into the device : +, Current flowing out of the device : -) (Ta=25°C, V<sub>cc</sub>=V<sub>K</sub>=3.0V)

| Parameter                         |                                     | Symbol                            | ** Conditions      | MIN.                 | TYP.  | MAX.            | Unit            | Application   |
|-----------------------------------|-------------------------------------|-----------------------------------|--------------------|----------------------|-------|-----------------|-----------------|---|
| "H" gain mode                     | Supply current                      | I <sub>CCP</sub>                  | —                  | 2.0                  | 5.2   | 9.0             | mA              | V <sub>cc</sub>   |
|                                   | Dark output voltage                 | V <sub>odP</sub>                  | —                  | 1.1                  | 1.4   | 1.6             | V               | V <sub>A</sub> , V <sub>B</sub> , V <sub>C</sub> , V <sub>D</sub> |
|                                   | Dark output differential voltage    | V <sub>odPS</sub>                 | —                  | -25                  | 0     | 25              | mV              | V <sub>A</sub> , V <sub>B</sub> , V <sub>C</sub> , V <sub>D</sub> |
|                                   | *6 Sensitivity                      | R <sub>pP</sub>                   | —                  | 13                   | 22.5  | 34              | mV/μW           | V <sub>A</sub> , V <sub>B</sub> , V <sub>C</sub> , V <sub>D</sub> |
|                                   | Sensitivity temperature coefficient | R <sub>pPt</sub>                  | Ta=-20 to +70°C    | —                    | +7000 | —               | ppm/°C          | V <sub>A</sub> , V <sub>B</sub> , V <sub>C</sub> , V <sub>D</sub> |
|                                   | Response frequency                  | f <sub>CP</sub>                   | -3dB               | 3.0                  | 5.3   | —               | MHz             | V <sub>A</sub> , V <sub>B</sub> , V <sub>C</sub> , V <sub>D</sub> |
| "L" gain mode                     | Output noise level                  | V <sub>nP</sub>                   | f=720kHz, BW=10kHz | —                    | -90   | -80             | dBm             | V <sub>A</sub> , V <sub>B</sub> , V <sub>C</sub> , V <sub>D</sub> |
|                                   | Supply current                      | I <sub>CCR</sub>                  | —                  | 3.0                  | 5.6   | 10.0            | mA              | V <sub>cc</sub>   |
|                                   | Dark output voltage                 | V <sub>odR</sub>                  | —                  | 1.1                  | 1.35  | 1.6             | V               | V <sub>A</sub> , V <sub>B</sub> , V <sub>C</sub> , V <sub>D</sub> |
|                                   | Dark output differential voltage    | V <sub>odRS</sub>                 | —                  | -25                  | 0     | 25              | mV              | V <sub>A</sub> , V <sub>B</sub> , V <sub>C</sub> , V <sub>D</sub> |
|                                   | *7 Sensitivity                      | R <sub>pR</sub>                   | —                  | 1.3                  | 2.8   | 4.9             | mV/μW           | V <sub>A</sub> , V <sub>B</sub> , V <sub>C</sub> , V <sub>D</sub> |
|                                   | Sensitivity temperature coefficient | R <sub>pRt</sub>                  | Ta=-20 to +70°C    | —                    | +7000 | —               | ppm/°C          | V <sub>A</sub> , V <sub>B</sub> , V <sub>C</sub> , V <sub>D</sub> |
| Common to both modes              | Response frequency                  | f <sub>CR</sub>                   | -3dB               | 2.0                  | 3.8   | —               | MHz             | V <sub>A</sub> , V <sub>B</sub> , V <sub>C</sub> , V <sub>D</sub> |
|                                   | Output noise level 1                | V <sub>nR1</sub>                  | f=22kHz, BW=1kHz   | —                    | -100  | -90             | dBm             | V <sub>A</sub> , V <sub>B</sub> , V <sub>C</sub> , V <sub>D</sub> |
|                                   | Output noise level 2                | V <sub>nR2</sub>                  | f=720kHz, BW=10kHz | —                    | -90   | -80             | dBm             | V <sub>A</sub> , V <sub>B</sub> , V <sub>C</sub> , V <sub>D</sub> |
|                                   | Sensitivity                         | R <sub>pE</sub> , R <sub>pF</sub> | —                  | 0.28                 | 0.37  | 0.52            | μA/μW           | I <sub>E</sub> , I <sub>F</sub>                                   |
|                                   | Output current                      | I <sub>O</sub>                    | —                  | 240                  | 430   | 700             | μA              | V <sub>A</sub> , V <sub>B</sub> , V <sub>C</sub> , V <sub>D</sub> |
|                                   | Dark current                        | I <sub>dE</sub> , I <sub>dF</sub> | —                  | —                    | —     | 10              | nA              | I <sub>E</sub> , I <sub>F</sub>                                   |
|                                   | Terminal capacitance                | C <sub>AK</sub>                   | —                  | —                    | (20)  | —               | pF              | I <sub>E</sub> , I <sub>F</sub>                                   |
|                                   | Mode switching terminal voltage 1   | V <sub>MR</sub>                   | —                  | V <sub>cc</sub> -0.5 | —     | V <sub>cc</sub> | V               | M <sub>PR</sub>   |
|                                   | Mode switching terminal voltage 2   | V <sub>MP</sub>                   | —                  | 0                    | —     | 0.4             | V               | M <sub>PR</sub>   |
|                                   | Mode switching terminal current 1   | I <sub>MR</sub>                   | —                  | —                    | —     | 230             | μA              | M <sub>PR</sub>   |
| Mode switching terminal current 2 | I <sub>MP</sub>                     | —                                 | —                  | —                    | -0.5  | μA              | M <sub>PR</sub> |   |
| Mode switching characteristics    | Sensitivity response                | R <sub>pRP</sub>                  | *10                | 11.7                 | 22.5  | 35.7            | mV/μW           | V <sub>A</sub> , V <sub>B</sub> , V <sub>C</sub> , V <sub>D</sub> |
|                                   | Sensitivity response                | R <sub>pPR</sub>                  | *10                | 1.2                  | 2.8   | 5.2             | mV/μW           | V <sub>A</sub> , V <sub>B</sub> , V <sub>C</sub> , V <sub>D</sub> |

\*6 Specified by sampling test

\*7 6μW, φ50μm of DC light is applied to the center of each photodiode.

Under that condition, sensitivity R<sub>pP</sub> is shown by following formula.

$$R_{pP} = (V_{pP} - V_{odP}) / 6\mu W$$

V<sub>pP</sub> : Output voltage when DC light is applied.

V<sub>odP</sub> : Output voltage when DC light is not applied.

\*8 50μW φ50μm of DC light is applied to the center of each photodiode.

Under that condition, sensitivity R<sub>pR</sub> is shown by following formula.

$$R_{pR} = (V_{pR} - V_{odR}) / 50\mu W$$

V<sub>pR</sub> : Output voltage when DC light is applied.

V<sub>odR</sub> : Output voltage when DC light is not applied.

\*9 Playback mode : V<sub>M<sub>PR</sub></sub>=0V Recording mode : V<sub>M<sub>PR</sub></sub>=V<sub>cc</sub>.

\*10 Sensitivity response characteristics after switching mode is specified in the sensitivity in 200μs after change of the mode switching voltage. Take measurement with 20μ W DC light radiated to the center of each photodiode at 50μmφ.

$$R_{pP} = (V_{pP} - V_{odP}) / 20\mu W$$

Fig.1 Response Time

"L" gain mode → "H" gain mode switching time

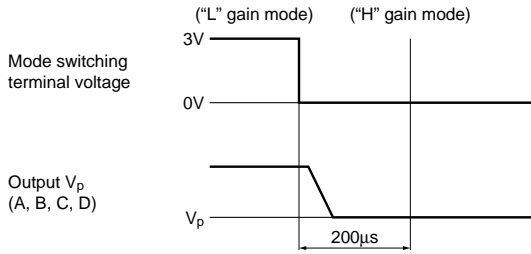

Fig.2 Response Time

"H" gain mode → "L" gain mode switching time

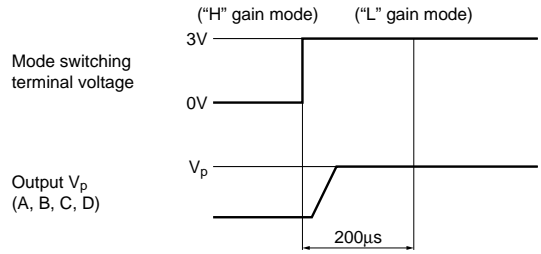

Fig.3 Detecting Pattern of Photodiode

(Unit : µm)

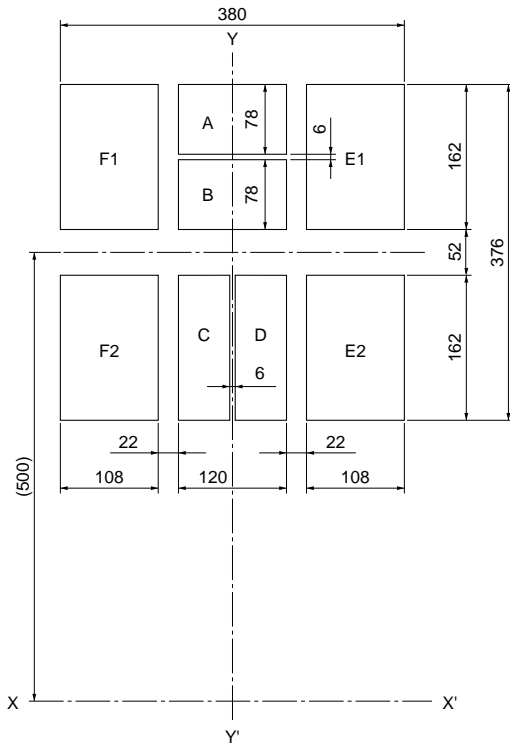
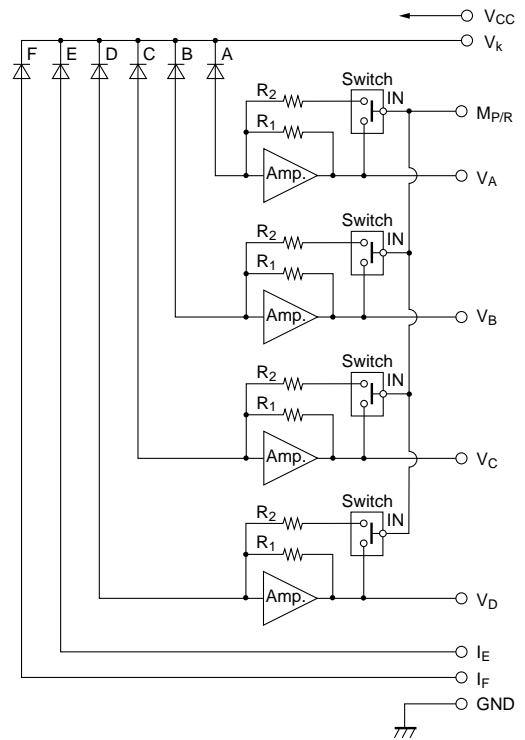

Fig.4 Block Diagram



The switching circuit operates according to H and L voltage of the Mp/R terminals.

| Mode          | Mp/R terminal voltage | SW state | Gain resistance                |
|---------------|-----------------------|----------|--------------------------------|
| "H" gain mode | L                     | OFF      | R <sub>1</sub>                 |
| "L" gain mode | H                     | ON       | R <sub>1</sub> /R <sub>2</sub> |

**Fig.5 Supply Current vs. Ambient Temperature (H Gain Mode)**

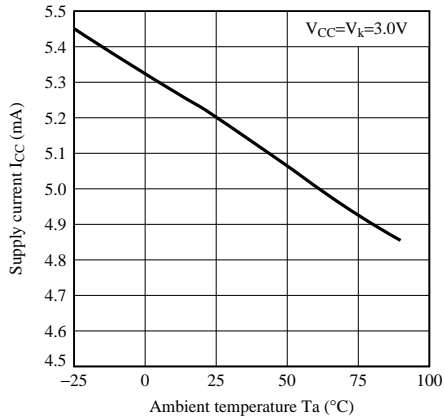

**Fig.6 Supply Current vs. Ambient Temperature (L Gain Mode)**

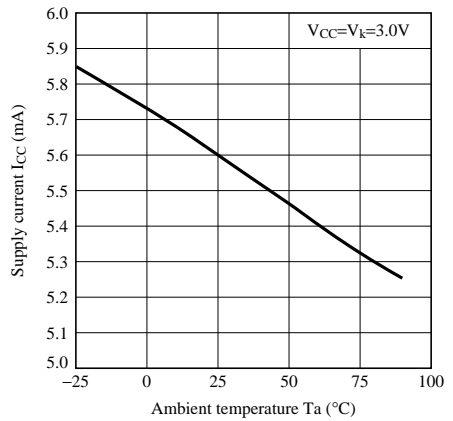

**Fig.7 Response Frequency vs. Ambient Temperature (H Gain Mode)**

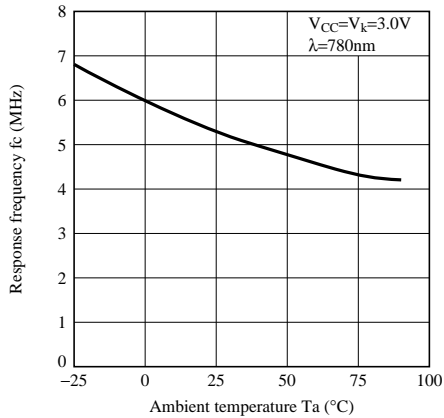

**Fig.8 Response Frequency vs. Ambient Temperature (L Gain Mode)**

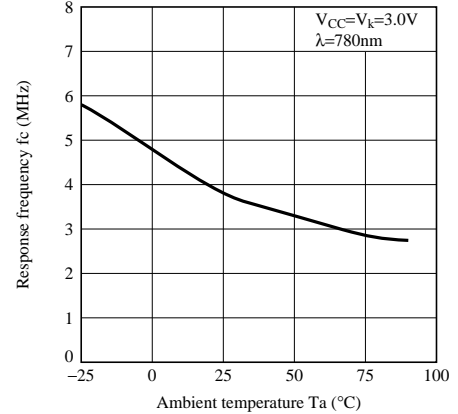

**Fig.9 Dark Output Voltage vs. Ambient Temperature (H Gain Mode)**

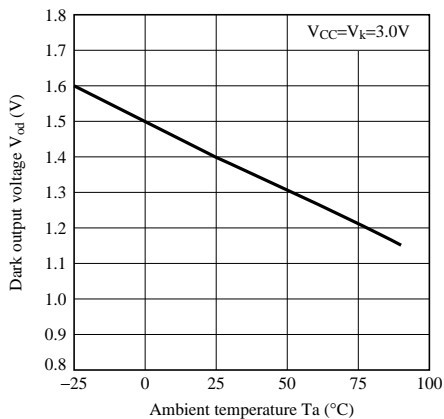

**Fig.10 Dark Output Voltage vs. Ambient Temperature (L Gain Mode)**

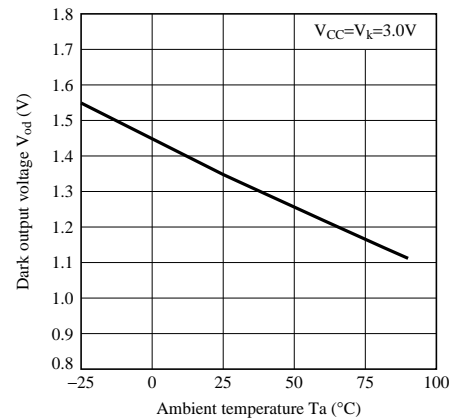

**Fig.11 Sensitivity vs. Ambient Temperature (H Gain Mode)**

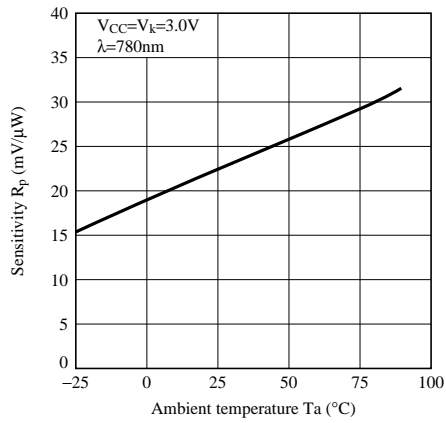

**Fig.12 Sensitivity vs. Ambient Temperature (L Gain Mode)**

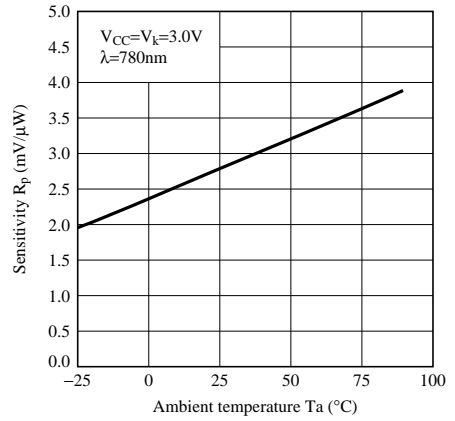

**Fig.13 Sensitivity vs. Ambient Temperature (H/L Gain Mode)**

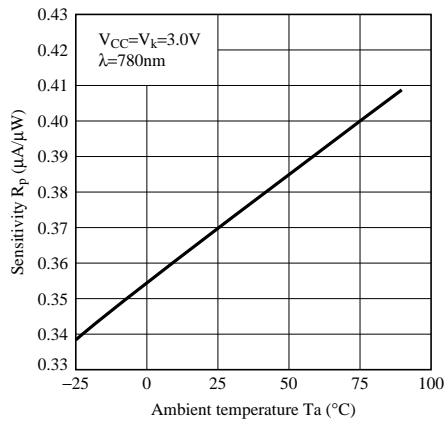

### NOTICE

- The circuit application examples in this publication are provided to explain representative applications of SHARP devices and are not intended to guarantee any circuit design or license any intellectual property rights. SHARP takes no responsibility for any problems related to any intellectual property right of a third party resulting from the use of SHARP's devices.
- Contact SHARP in order to obtain the latest device specification sheets before using any SHARP device. SHARP reserves the right to make changes in the specifications, characteristics, data, materials, structure, and other contents described herein at any time without notice in order to improve design or reliability. Manufacturing locations are also subject to change without notice.
- Observe the following points when using any devices in this publication. SHARP takes no responsibility for damage caused by improper use of the devices which does not meet the conditions and absolute maximum ratings to be used specified in the relevant specification sheet nor meet the following conditions:
  - (i) The devices in this publication are designed for use in general electronic equipment designs such as:
    - Personal computers
    - Office automation equipment
    - Telecommunication equipment [terminal]
    - Test and measurement equipment
    - Industrial control
    - Audio visual equipment
    - Consumer electronics
  - (ii) Measures such as fail-safe function and redundant design should be taken to ensure reliability and safety when SHARP devices are used for or in connection with equipment that requires higher reliability such as:
    - Transportation control and safety equipment (i.e., aircraft, trains, automobiles, etc.)
    - Traffic signals
    - Gas leakage sensor breakers
    - Alarm equipment
    - Various safety devices, etc.
  - (iii) SHARP devices shall not be used for or in connection with equipment that requires an extremely high level of reliability and safety such as:
    - Space applications
    - Telecommunication equipment [trunk lines]
    - Nuclear power control equipment
    - Medical and other life support equipment (e.g., scuba).
- Contact a SHARP representative in advance when intending to use SHARP devices for any "specific" applications other than those recommended by SHARP or when it is unclear which category mentioned above controls the intended use.
- If the SHARP devices listed in this publication fall within the scope of strategic products described in the Foreign Exchange and Foreign Trade Control Law of Japan, it is necessary to obtain approval to export such SHARP devices.
- This publication is the proprietary product of SHARP and is copyrighted, with all rights reserved. Under the copyright laws, no part of this publication may be reproduced or transmitted in any form or by any means, electronic or mechanical, for any purpose, in whole or in part, without the express written permission of SHARP. Express written permission is also required before any use of this publication may be made by a third party.
- Contact and consult with a SHARP representative if there are any questions about the contents of this publication.