

Radiation Hardened Hex Inverter with Open Drain

September 1995

Features

- 3 Micron Radiation Hardened SOS CMOS
- Total Dose 200K RAD (Si)
- SEP Effective LET No Upsets: >100 MEV-cm²/mg
- Single Event Upset (SEU) Immunity < 2 x 10⁻⁹ Errors/Bit-Day (Typ)
- Dose Rate Survivability: >1 x 10¹² RAD (Si)/s
- Dose Rate Upset >10¹⁰ RAD (Si)/s 20ns Pulse
- Latch-Up Free Under Any Conditions
- Military Temperature Range: -55°C to +125°C
- Significant Power Reduction Compared to LSTTL ICs
- DC Operating Voltage Range: 4.5V to 5.5V
- Input Logic Levels
 - VIL = 30% of VCC Max
 - VIH = 70% of VCC Min
- Input Current Levels $I_i \leq 5\mu\text{A}$ at VOL, VOH

Description

The Harris HCS05MS is a Radiation Hardened Hex inverter function with open drain outputs. These open drain outputs can drive into resistive loads with a separate voltage supply.

The HCS05MS utilizes advanced CMOS/SOS technology to achieve high-speed operation. This device is a member of radiation hardened, high-speed, CMOS/SOS Logic Family.

The HCS05MS is supplied in a 14 lead Ceramic Flatpack (K suffix) or a Ceramic Dual-In-Line Package (D suffix).

Ordering Information

PART NUMBER	TEMPERATURE RANGE	SCREENING LEVEL	PACKAGE
HCS05DMSR	-55°C to +125°C	Harris Class S Equivalent	14 Lead SBDIP
HCS05KMSR	-55°C to +125°C	Harris Class S Equivalent	14 Lead Ceramic Flatpack
HCS05D/ Sample	+25°C	Sample	14 Lead SBDIP
HCS05K/ Sample	+25°C	Sample	14 Lead Ceramic Flatpack
HCS05HMSR	+25°C	Die	Die

Pinouts

14 LEAD CERAMIC DUAL-IN-LINE METAL SEAL PACKAGE (SBDIP)
MIL-STD-1835 CDIP2-T14, LEAD FINISH C
TOP VIEW

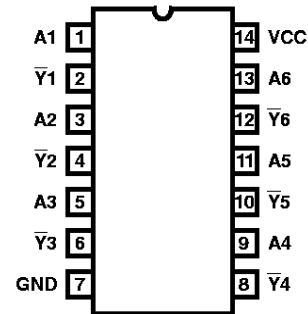

14 LEAD CERAMIC METAL SEAL FLATPACK PACKAGE (FLATPACK)
MIL-STD-1835 CDFP3-F14, LEAD FINISH C
TOP VIEW

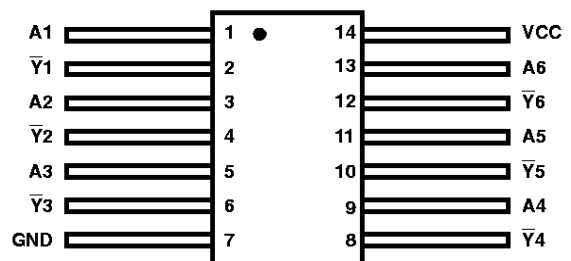

Functional Diagram

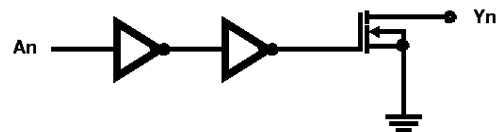

TRUTH TABLE

INPUTS	OUTPUTS	
An	Yn	
L	Z (Note 1)	H (Note 2)
H	L	

NOTES:

1. No pullup resistor
2. With pullup resistor
3. L = Low
4. H = High

Specifications HCS05MS

Absolute Maximum Ratings

Supply Voltage	-0.5V to +7.0V
Input Voltage Range, All Inputs	-0.5V to VCC +0.5V
DC Input Current, Any One Input	±10mA
DC Drain Current, Any One Output (All Voltage Reference to the VSS Terminal)	±25mA
Storage Temperature Range (TSTG)	-65°C to +150°C
Junction Temperature (TJ)	+175°C
Lead Temperature (Soldering 10sec)	+265°C
ESD Classification	Class 1

Reliability Information

Thermal Resistance	θ_{JA}	θ_{JC}
SBDIP Package	74°C/W	24°C/W
Ceramic Flatpack Package	116°C/W	30°C/W
Maximum Package Power Dissipation at +125°C Ambient		
SBDIP Package	0.68W	
Ceramic Flatpack Package	0.43W	
If device power exceeds package dissipation capability, provide heat sinking or derate linearly at the following rate:		
SBDIP Package	13.5mW/°C	
Ceramic Flatpack Package	8.6mW/°C	

CAUTION: As with all semiconductors, stress listed under "Absolute Maximum Ratings" may be applied to devices (one at a time) without resulting in permanent damage. This is a stress rating only. Exposure to absolute maximum rating conditions for extended periods may affect device reliability. The conditions listed under "Electrical Performance Characteristics" are the only conditions recommended for satisfactory device operation..

Operating Conditions

Supply Voltage	+4.5V to +5.5V	Input High Voltage (VIH)	70% of VCC
Input Rise and Fall Times at 4.5V VCC (TR, TF)	100ns/V Max	Input Low Voltage (VIL)	0.0V to 30% of VCC
Operating Temperature Range (TA)	-55°C to +125°C		

TABLE 1. DC ELECTRICAL PERFORMANCE CHARACTERISTICS

PARAMETER	SYMBOL	(NOTE 1) CONDITIONS	GROUP A SUB- GROUPS	TEMPERATURE	LIMITS		UNITS
					MIN	MAX	
Supply Current	ICC	VCC = 5.5V, VIN = VCC or GND	1	+25°C	-	10	μA
			2, 3	+125°C, -55°C	-	200	μA
Output Current (Sink)	IOL	VCC = VIH = 4.5V, VOUT = 0.4V, VIL = 0V (Note 2)	1	+25°C	4.8	-	mA
			2, 3	+125°C, -55°C	4.0	-	mA
Output Voltage Low	VOL	VCC = 5.5V, VIH = 3.85V, VIL = 1.35V, IOL = 50μA	1, 2, 3	+25°C, +125°C, -55°C	-	0.1	V
		VCC = 4.5V, VIH = 3.15V, VIL = 1.35V, IOL = 50μA,	1, 2, 3	+25°C, +125°C, -55°C	-	0.1	V
Input Leakage Current	IIN	VCC = 5.5V, VIN = VCC or GND	1	+25°C	-	±0.5	μA
			2, 3	+125°C, -55°C	-	±5.0	μA
Three-State Output Leakage Current	IOZH	VCC = 5.5V, Force Voltage = VCC	1	+25°C	-	1	μA
			2, 3	+125°C, -55°C	-	50	μA
Noise Immunity Functional Test	FN	VCC = 4.5V, VIH = 3.15, VIL = 1.35 (Note 3)	7, 8A, 8B	+25°C, +125°C, -55°C	-	-	V

NOTES:

1. All voltages reference to device GND.
2. Force/Measure functions may be interchanged.
3. For functional tests, $VO \geq 4.0V$ is recognized as a logic "1", and $VO \leq 0.5V$ is recognized as a logic "0".

TABLE 2. AC ELECTRICAL PERFORMANCE CHARACTERISTICS

PARAMETER	SYMBOL	(NOTES 1, 2) CONDITIONS	GROUP A SUB- GROUPS	TEMPERATURE	LIMITS		UNITS
					MIN	MAX	
Propagation Delay An to Yn	TPLZ TPZL	VCC = 4.5V, VIH = 4.5V, VIL = 0V	9	+25°C	2	18	ns
			10, 11	+125°C, -55°C	2	20	ns

NOTES:

1. All voltages referenced to device GND.
2. Measurements assume $RL = 500\Omega$, $CL = 50pF$, Input $TR = TF = 3ns$.

Specifications HCS05MS

TABLE 3. ELECTRICAL PERFORMANCE CHARACTERISTICS

PARAMETER	SYMBOL	CONDITIONS	NOTES	TEMPERATURE	LIMITS		UNITS
					MIN	MAX	
Capacitance Power Dissipation	CPD	VCC = 5.0V, VIH = 5.0V, VIL = 0.0V, f = 1MHz	1	+25°C	-	15	pF
				+125°C, -55°C	-	23	pF
Input Capacitance	CIN	VCC = 5.0V, VIH = 5.0V, VIL = 0.0V, f = 1MHz	1	+25°C	-	10	pF
				+125°C, -55°C	-	10	pF
Output Transition Time	TTHL	VCC = 4.5V, VIH = 4.5V, VIL = 0.0V	1	+25°C	1	15	ns
				+125°C, -55°C	1	22	ns

NOTE:

- The parameters listed in Table 3 are controlled via design or process parameters. Min and Max Limits are guaranteed but not directly tested. These parameters are characterized upon initial design release and upon design changes which affect these characteristics.

TABLE 4. POST IRRADIATION ELECTRICAL PERFORMANCE CHARACTERISTICS

PARAMETER	SYMBOL	(NOTE 1) CONDITIONS	TEMPERATURE	200K RAD LIMITS		UNITS
				MIN	MAX	
Supply Current	ICC	VCC = 5.5V, VIN = VCC or GND	+25°C	-	0.2	mA
Output Current (Sink)	IOL	VCC = VIH = 4.5V, VOUT = 0.4V, VIL = 0V	+25°C	4.0	-	mA
Output Voltage Low	VOL	VCC = 5.5V, VIH = 3.85V, VIL = 1.65V, IOL = 50μA	+25°C	-	0.1	V
		VCC = 4.5V, VIH = 3.15V, VIL = 1.35V, IOL = 50μA	+25°C	-	0.1	V
Input Leakage Current	IIN	VCC = 5.5V, VIN = VCC or GND	+25°C	-	±5	μA
Three-State Output Leakage Current	IOZH	VCC = 5.5V, Force Voltage = 0V or VCC	+25°C	-	±50	μA
Noise Immunity Functional Test	FN	VCC = 4.5V, VIH = 3.15V, VIL = 1.35V, (Note 2)	+25°C	-	-	V
Propagation Delay	TPLZ TPZL	VCC = 4.5V, VIH = 4.5V, VIL = 0V	+25°C	2	20	ns

NOTES:

- All voltages referenced to device GND.
- For functional tests, $VO \geq 4.0V$ is recognized as a logic "1", and $VO \leq 0.5V$ is recognized as a logic "0".

TABLE 5. DELTA PARAMETERS (+25°C)

PARAMETER	SYMBOL	GROUP B SUBGROUP	UNITS
Supply Current	ICC	+3	μA
Three-State Leaking Current	IOZH	±200	nA
Output Current	IOL	-15	%

Specifications HCS05MS

TABLE 6. APPLICABLE SUBGROUPS

CONFORMANCE GROUPS		METHOD	GROUP A SUBGROUPS	READ AND RECORD
Initial Test (Preburn-In)		100%/5004	1, 7, 9	ICC, IOL, IOZH
Interim Test I (Postburn-In)		100%/5004	1, 7, 9	ICC, IOL, IOZH
Interim Test II (Postburn-In)		100%/5004	1, 7, 9	ICC, IOL/H
PDA		100%/5004	1, 7, 9, Deltas	
Interim Test III (Postburn-In)		100%/5004	1, 7, 9	ICC, IOL, IOZH
PDA		100%/5004	1, 7, 9, Deltas	
Final Test		100%/5004	2, 3, 8A, 8B, 10, 11	
Group A (Note 1)		Sample/5005	1, 2, 3, 7, 8A, 8B, 9, 10, 11	
Group B	Subgroup B-5	Sample/5005	1, 2, 3, 7, 8A, 8B, 9, 10, 11, Deltas	Subgroups 1, 2, 3, 9, 10, 11
	Subgroup B-6	Sample/5005	1, 7, 9	
Group D		Sample/5005	1, 7, 9	

NOTE:

1. Alternate Group A testing in accordance with Method 5005 of MIL-STD-883 may be exercised.

TABLE 7. TOTAL DOSE IRRADIATION

CONFORMANCE GROUPS	METHOD	TEST		READ AND RECORD	
		PRE RAD	POST RAD	PRE RAD	POST RAD
Group E Subgroup 2	5005	1, 7, 9	Table 4	1, 9	Table 4 (Note 1)

NOTE:

1. Except FN test which will be performed 100% Go/No-Go.

TABLE 8. STATIC AND DYNAMIC BURN-IN TEST CONNECTIONS

OPEN	GROUND	VCC = 6V ± 0.5V	1/2 VCC = 3V ± 0.5V	OSCILLATOR	
				50kHz	25kHz
STATIC BURN-IN I TEST CONDITIONS (Note 1)					
-	1, 3, 5, 7, 9, 11, 13	2, 4, 6, 8, 10, 12, 14	-	-	-
STATIC BURN-IN II TEST CONNECTIONS (Note 1)					
2, 4, 6, 8, 10, 12	7	1, 3, 5, 9, 11, 13, 14	-	-	-
DYNAMIC BURN-IN I TEST CONNECTIONS (Note 2)					
-	7	14	2, 4, 6, 8, 10, 12	1, 3, 5, 9, 11, 13	-

NOTES:

1. Each pin except VCC and GND will have a series resistor of 10KΩ ± 5%.
2. Each pin except VCC and GND will have a series resistor of 1KΩ ± 5%.

TABLE 9. IRRADIATION TEST CONNECTIONS

FUNCTION	OPEN	GROUND	VCC = 5V ± 0.5V
Irradiation Circuit (Note 1)	2, 4, 6, 8, 10, 12	7	1, 3, 5, 9, 11, 13, 14

NOTE: Each pin except VCC and GND will have a resistor of 47KΩ ± 5% for irradiation testing. Group E, Subgroup 2, sample size is 4 dice/wafe,r 0 failures.

Harris Space Level Product Flow - 'MS'

Wafer Lot Acceptance (All Lots) Method 5007 (Includes SEM)	100% Interim Electrical Test 1 (T1) 100% Delta Calculation (T0-T1)
GAMMA Radiation Verification (Each Wafer) Method 1019, 4 Samples/Wafer, 0 Rejects	100% Static Burn-In 2, Condition A or B, 24 hrs. min., +125°C min., Method 1015
100% Nondestructive Bond Pull, Method 2023	100% Interim Electrical Test 2 (T2)
Sample - Wire Bond Pull Monitor, Method 2011	100% Delta Calculation (T0-T2)
Sample - Die Shear Monitor, Method 2019 or 2027	100% PDA 1, Method 5004 (Notes 1 and 2)
100% Internal Visual Inspection, Method 2010, Condition A	100% Dynamic Burn-In, Condition D, 240 hrs., +125°C or Equivalent, Method 1015
100% Temperature Cycle, Method 1010, Condition C, 10 Cycles	100% Interim Electrical Test 3 (T3)
100% Constant Acceleration, Method 2001, Condition per Method 5004	100% Delta Calculation (T0-T3)
100% PIND, Method 2020, Condition A	100% PDA 2, Method 5004 (Note 2)
100% External Visual	100% Final Electrical Test
100% Serialization	100% Fine/Gross Leak, Method 1014
100% Initial Electrical Test (T0)	100% Radiographic, Method 2012 (Note 3)
100% Static Burn-In 1, Condition A or B, 24 hrs. min., +125°C min., Method 1015	100% External Visual, Method 2009 Sample - Group A, Method 5005 (Note 4) 100% Data Package Generation (Note 5)

NOTES:

1. Failures from Interim electrical test 1 and 2 are combined for determining PDA 1.
2. Failures from subgroup 1, 7, 9 and deltas are used for calculating PDA. The maximum allowable PDA = 5% with no more than 3% of the failures from subgroup 7.
3. Radiographic (X-Ray) inspection may be performed at any point after serialization as allowed by Method 5004.
4. Alternate Group A testing may be performed as allowed by MIL-STD-883, Method 5005.
5. Data Package Contents:
 - Cover Sheet (Harris Name and/or Logo, P.O. Number, Customer Part Number, Lot Date Code, Harris Part Number, Lot Number, Quantity).
 - Wafer Lot Acceptance Report (Method 5007). Includes reproductions of SEM photos with percent of step coverage.
 - GAMMA Radiation Report. Contains Cover page, disposition, Rad Dose, Lot Number, Test Package used, Specification Numbers, Test equipment, etc. Radiation Read and Record data on file at Harris.
 - X-Ray report and film. Includes penetrometer measurements.
 - Screening, Electrical, and Group A attributes (Screening attributes begin after package seal).
 - Lot Serial Number Sheet (Good units serial number and lot number).
 - Variables Data (All Delta operations). Data is identified by serial number. Data header includes lot number and date of test.
 - The Certificate of Conformance is a part of the shipping invoice and is not part of the Data Book. The Certificate of Conformance is signed by an authorized Quality Representative.

Three-State Low Timing Diagram and Load Circuit

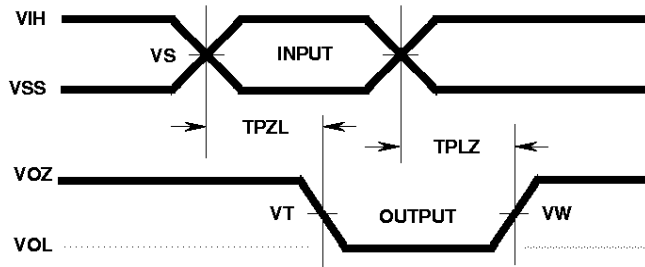

Transition Timing Diagram

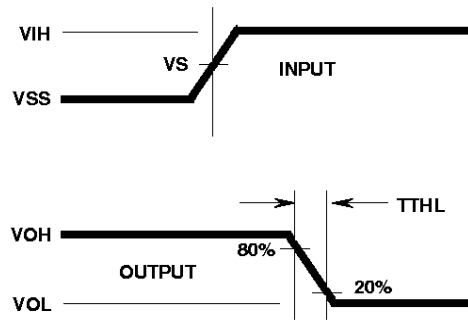

THREE-STATE LOW VOLTAGE LEVELS

PARAMETER	HCS	UNITS
VCC	4.50	V
VIH	4.50	V
VS	2.25	V
VT	2.25	V
VW	0.90	V
GND	0	V

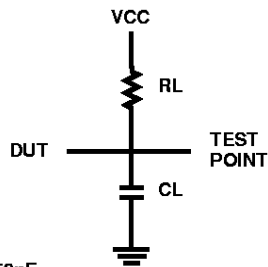

CL = 50pF
RL = 500Ω

HCS05MS

Die Characteristics

DIE DIMENSIONS:

87 x 88 mils
2.20mm x 2.24mm

METALLIZATION:

Type: AlSi
Metal Thickness: $11\text{k}\text{\AA} \pm 1\text{k}\text{\AA}$

GLASSIVATION:

Type: SiO_2
Thickness: $13\text{k}\text{\AA} \pm 2.6\text{k}\text{\AA}$

WORST CASE CURRENT DENSITY:

$<2.0 \times 10^5 \text{A/cm}^2$

BOND PAD SIZE:

$100\mu\text{m} \times 100\mu\text{m}$
4 x 4 mils

Metallization Mask Layout

