

# S18UUAQ

## Ultrasonic sensor – diffuse mode sensor

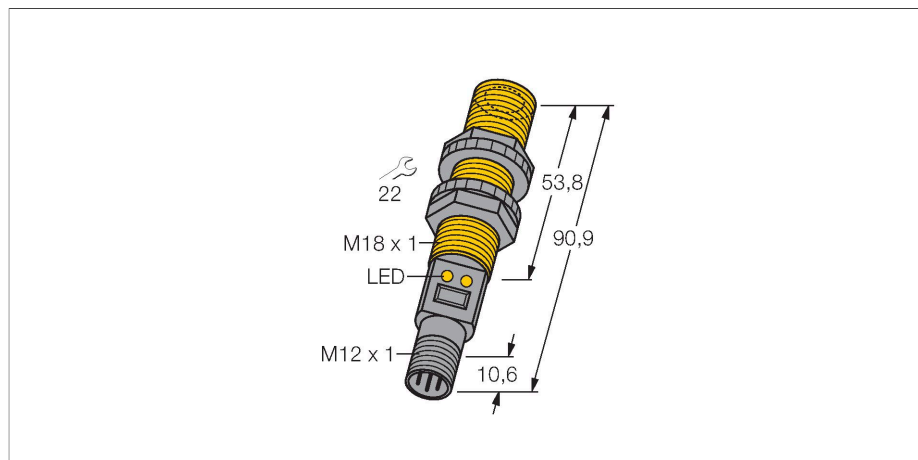

### Features

- Compact design
- Connection via male M12 x 1
- Temperature compensation
- Very small blind zone
- Measuring range adjustable via teach-in
- Blind zone: 3 cm
- Range: 30 cm

### Wiring diagram

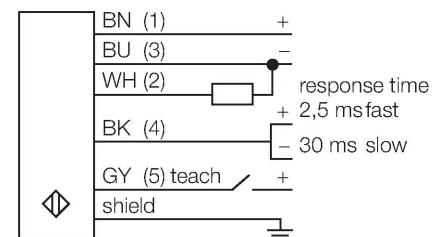

### Technical data

Type	S18UUAQ
ID	3002700
<b>Ultrasonic data</b>	
Function	Proximity switch
Range	30...300 mm
Ultrasound frequency	300 kHz
Repeatability	$\leq \pm 0.25$ mm
Temperature drift	$\pm 0.3$ % of full scale
Edge lengths of the nominal actuator	50 mm
<b>Electrical data</b>	
Operating voltage	10...30 VDC
No-load current	$\leq 100$ mA
Response time typical	$< 2.5$ ms
Readiness delay	$\leq 300$ ms
Output function	Analog output
Voltage output	0...10 V
Short-circuit protection	yes
Reverse polarity protection	Complete
Wire breakage protection	yes
<b>Mechanical data</b>	
Design	Tube, S18U
Radiation direction	straight
Dimensions	$\varnothing 18 \times 90.9$ mm
Housing material	Plastic, ABS/Polycarbonate
Transducer material	Plastic, Epoxyd resin and PU foam
Electrical connection	Connector, M12 x 1, PVC

### Functional principle

Ultrasonic sensors detect a multitude of objects contactless and wear-free with ultrasonic waves. Regardless of whether the object is transparent or opaque, metallic or non-metallic, liquid, solid or powdery. Even environmental conditions such as spray, dust or rain hardly affect their function.

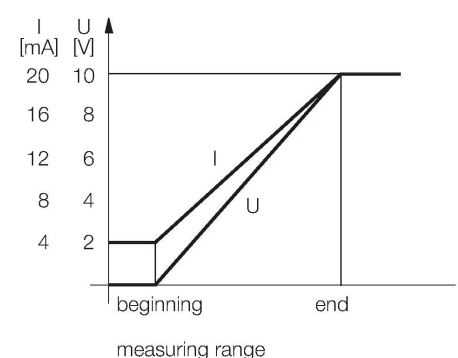

## Technical data

Ambient temperature	-20...+60 °C
Storage temperature	-40...+80 °C
Relative humidity	100 %
Protection class	IP67
Power-on indication	LED
Switching state	LED
Object detected	LED, Green
<b>Tests/approvals</b>	
MTTF	53 years acc. to SN 29500 (Ed. 99) 40 °C
Approvals	CE, cURus

## Accessories

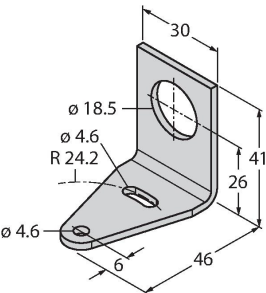
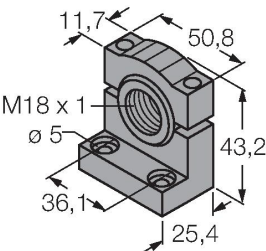
<b>SMB18A</b>	<b>3033200</b>	<b>SMB18FM</b>	<b>3079421</b>
	Mounting bracket, rectangular, stainless steel, for sensors with 18 mm thread		mounting bracket, black, M22 x1.5 mm, male thread, female thread M18 x 1, for sensors with 18 mm thread
<b>SMB18SF</b>	<b>3052519</b>		
	Mounting bracket, PBT black, for sensors with 18 mm thread, rotatable		

## Accessories

Dimension drawing	Type	ID	
	RKC4.5T-2/TEL	6625016	Connection cable, female M12, straight, 5-pin, cable length: 2 m, sheath material: PVC, black; cULus approval; other cable lengths and qualities available, see <a href="http://www.turck.com">www.turck.com</a>

Dimension drawing	Type	ID	
	WKC4.5T-2/TEL	6625028	Connection cable, female M12, angled, 5-pin, cable length: 2 m, sheath material: PVC, black; cULus approval; other cable lengths and qualities available, see <a href="http://www.turck.com">www.turck.com</a>
	RKS4.5T-2/TEL	6626361	Connection cable, M12 female connector, straight, 5-pin, cable length: 2 m, sheath material: PVC, black; shielded; cULus approval; other cable lengths and qualities available, see <a href="http://www.turck.com">www.turck.com</a>
	WKS4.5T-2/TEL	6626364	Connection cable, M12 female connector, angled, 5-pin, cable length: 2 m, sheath material: PVC, black; shielded; cULus approval; other cable lengths and qualities available, see <a href="http://www.turck.com">www.turck.com</a>

## Accessories

Dimension drawing	Type	ID	
	UWG18-6.4	3076952	Ultrasonic focussing-adaptor for QS18U and S18U, internal diameter 6.4 mm

Dimension drawing	Type	ID	
	UWG18-5.0	3077342	Ultrasonic focussing-adapter for QS18U and S18U, internal diameter 5.0 mm

