

# ATM P/N

-In Conformity with IEEE1394b

## HO7 Series

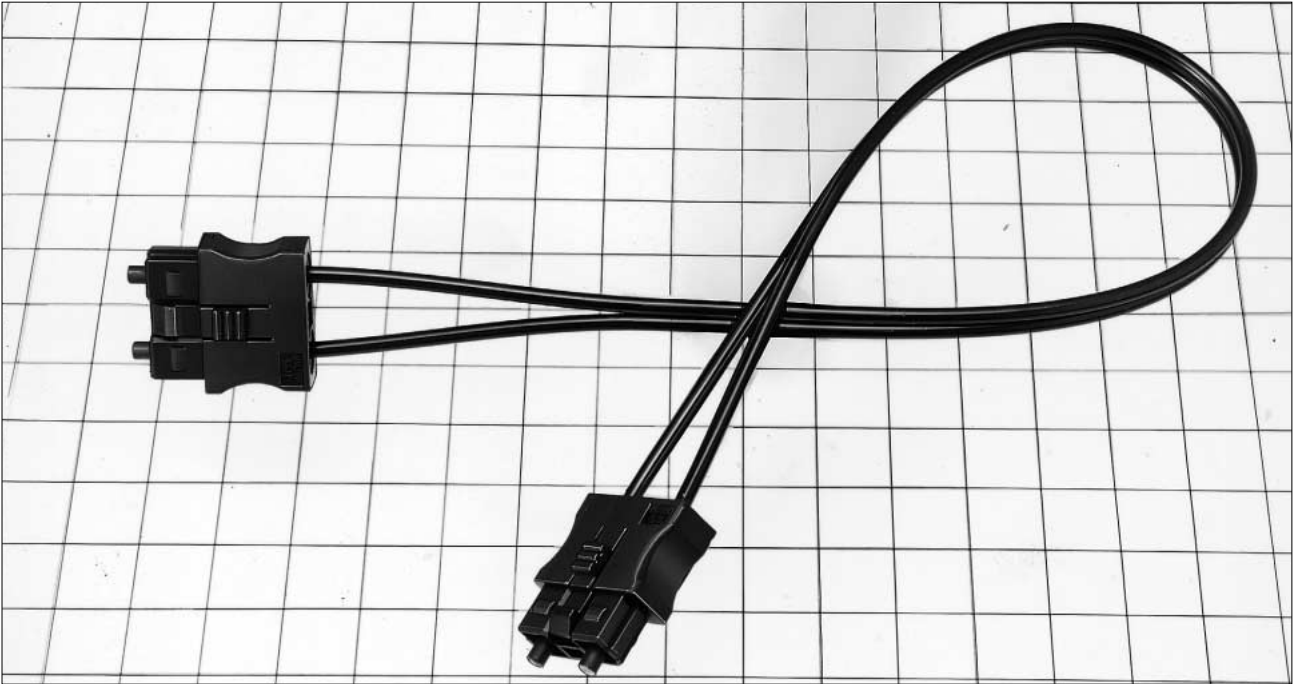

### ■Features

**1. The performance of this connector is in conformity with IEEE1394b.**

**2. Connectors for Use with POF (Plastic Fiber)**

These connectors have a single body design which includes the ferrules. The connectors are suited to transfer systems that are tens of meters in length.

**3. Connectors for Use with PCF (Plastic-Clad Silica Fiber)**

These connectors are of the floating ferrule type and are suited to transfer systems that are hundreds of meters in length.

**4. Ferrules**

These ferrules are metal parts and are economical compared to ones that use ceramics.

### ■Applications

Between equipment such as audio/video, factory automation, and office equipment, and short data links such as transfer systems within equipment.

**■Postscript** These connectors are based on JIS C 5976 F07-type duplex optical fiber connectors and reflect the addition of a friction lock mechanism and improved coupling stability. The connectors are ideal for use in transfer between equipment that is separated by short distances such as LAN and factory automation.

Connectors are available in a POF (plastic fiber) type suited to transfer systems that are tens of meters in length and PCF (plastic-clad silica fiber) type suited to transfer systems that are hundreds of meters in length.

Compatibility with the existing F07 connectors:

Connectors for POF: Not compatible

Connectors for PCF: Compatible

Note that revision discussions are planned for the current JIS to move in the direction of acquiring compatibility in 1997.

## Product Standards

Rating	Operating temperature range	-25°C~85°C	Storage temperature range	-25°C~85°C
--------	-----------------------------	------------	---------------------------	------------

Item		Test Method (JIS C 5961)	Standard
Mechanical Performance	Coupling force and separation force	Measure when connectors are coupled and separated in the direction of the axis at a speed of 50 mm/s.	Coupling force 39.2 N or less
	Repetitive operation	500 times	No damage, cracks, or part looseness
	Vibration resistance	Vibration range of 10 to 55 Hz, in 3 directions, 24 cycles each	
	Shock resistance	Acceleration of 981 m/s <sup>2</sup> , in the both directions along 3 axes, 3 times each (For a total of 18 times)	
Environmental performance	Humidity resistance (Temperature and humidity cycle)	Temperature: -10°C to 65°C Humidity 90 to 96% 10 cycles	
	Temperature cycle	Temperature -40 to 100°C, 100 cycles	
	Heat resistance	Leave for 240 hours at a temperature of 85°C	
	Cold resistance	Leave for 240 hours at a temperature of -40°C	
	Salt fog	Left in a 5% concentration of salt fog for 48 hours	No conspicuous corrosion

## Materials

Part name	Material
Plug casing	Polybutylene terphthalate
Ferrule	Copper alloy
Spring	Stainless steel

## Structure of the Product Number

**H07** — **CP** — **P1**

①                      ②                      ③

① Series Name
② CP: For PCF AP: For POF
③ P1: Plug 1 EP1: Plug 2

## Function Diagram

(1) Connectors for POF

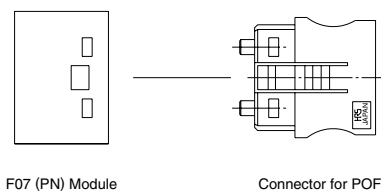

(2) Connectors for PCF

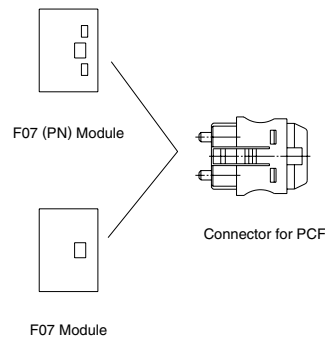

## ■Connectors for POF

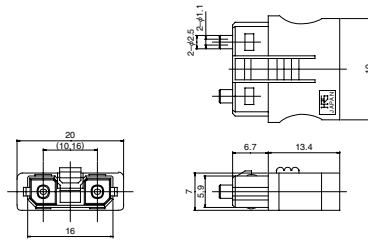
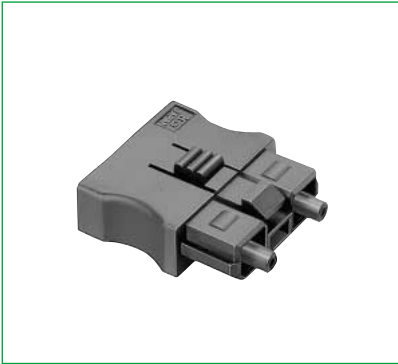

HRS No.	Product Number	Suitable Cable Diameter	Suitable Fiber Diameter	Notes
CL822-0001-6	H07-AP-P1	φ2.2mm	φ1mm	With ferrule

## ■Connectors for PCF

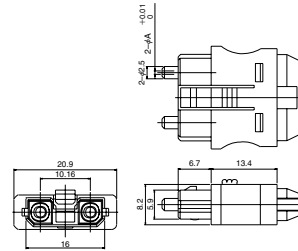

HRS No.	Product Number	φA Dimension	Suitable Cable Diameter	Suitable Fiber Diameter	Notes
CL822-0002-9	H07-CP-P1	-	-	-	No ferrule ※
CL822-0004-8	H07-CP-P1(F0235)	0.235	φ2.2mm	φ0.235	With ferrule
CL822-0015-0	H07-CP-P1(F0230)	0.230	φ2.2mm	φ0.23	With ferrule
CL822-0019-0	H07-CP-P1(F0300)	0.300	φ2.2mm	φ0.30	With ferrule

※ The photograph and the dimensions diagram show the type with ferrule.  
Please contact us about the type without a ferrule for details.

## ■Ferrules for PCF

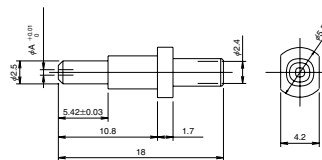
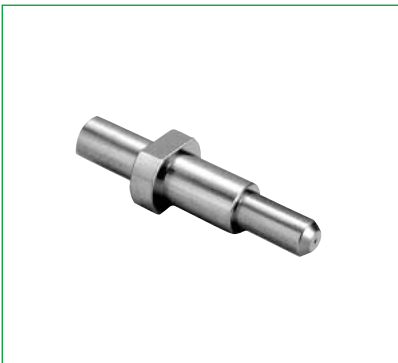

HRS No.	Product Number	φA Dimension	Suitable Cable Diameter	Suitable Fiber Diameter	Notes
CL822-0004-4	H07-CP-F0235	0.235	φ2.2mm	φ0.235	PCPCF
CL822-0006-6	H07-CP-F0230	0.230	φ2.2mm	φ0.23	
CL822-0018-9	H07-CP-F0300	0.300	φ2.2mm	φ0.30	

## ■Cable with Connector Attached

### ●Connectors for POF

HRS No.	Product Number	Suitable Fiber Diameter	Ferrule End Processing	Notes
CL822-2001-7	H07-P22-F2V2-L	SI-980/1000	Heat processing	Both ends

The "L" within the Product Number indicates the length of the cable. Please contact us for information about cable length. Please specify values of "L" in meter units.

