



MM54C74/MM74C74 Dual D Flip-Flop

General Description

The MM54C74/MM74C74 dual D flip-flop is a monolithic complementary MOS (CMOS) integrated circuit constructed with N- and P-channel enhancement transistors. Each flip-flop has independent data, preset, clear and clock inputs and Q and \bar{Q} outputs. The logic level present at the data input is transferred to the output during the positive going transition of the clock pulse. Preset or clear is independent of the clock and accomplished by a low level at the preset or clear input.

- Low power
- Medium speed operation

50 nW (typ.)
10 MHz (typ.)
with 10V supply

Applications

- Automotive
- Data terminals
- Instrumentation
- Medical electronics
- Alarm system
- Industrial electronics
- Remote metering
- Computers

Features

- Supply voltage range 3V to 15V
- Tenth power TTL compatible Drive 2 LPT²L loads
- High noise immunity 0.45 V_{CC} (typ.)

Logic Diagram

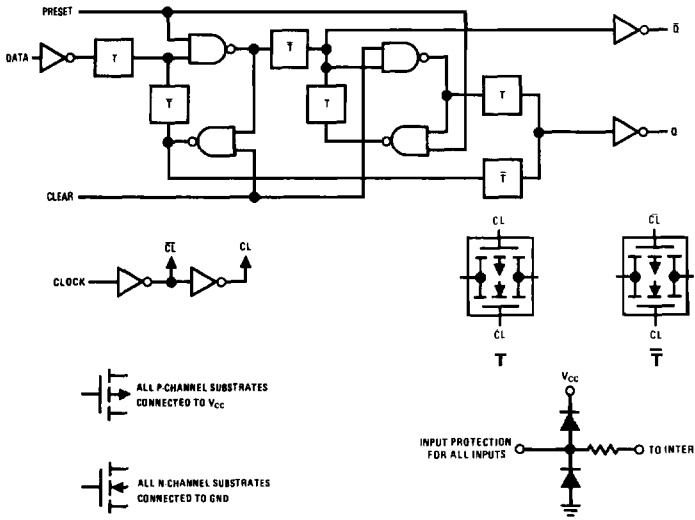

TL/F/5885-1

Truth Table

Preset	Clear	Q _n	\bar{Q}_n
0	0	0	0
0	1	1	0
1	0	0	1
1	1	*Q _n	* \bar{Q}_n

*No change in output from previous state.

Connection Diagram

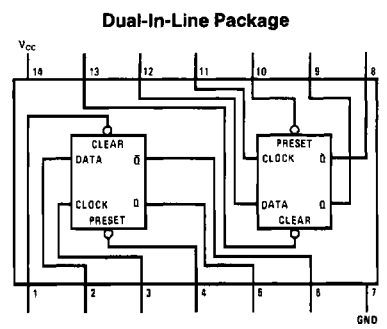

TL/F/5885-2

Order Number MM54C74* or MM74C74*

*Please look into Section 8, Appendix D for availability of various package types.

Note: A logic "0" on clear sets Q to logic "0".
A logic "0" on preset sets Q to logic "1".

Absolute Maximum Ratings (Note 1)

If Military/Aerospace specified devices are required, contact the National Semiconductor Sales Office/Distributors for availability and specifications.

Voltage at Any Pin (Note 1)	-0.3V to $V_{CC} + 0.3V$
Operating Temperature Range	
MM54C74	-55°C to +125°C
MM74C74	-40°C to +85°C

Storage Temperature Range	-65°C to +150°C
Power Dissipation	
Dual-In-Line	700 mW
Small Outline	500 mW
Lead Temperature (Soldering, 10 seconds)	260°C
Operating V_{CC} Range	3V to 15V
$V_{CC}(\text{Max})$	18V

DC Electrical Characteristics Min/Max limits apply across temperature range unless otherwise specified

Symbol	Parameter	Conditions	Min	Typ	Max	Units
CMOS TO CMOS						
$V_{IN(1)}$	Logical "1" Input Voltage	$V_{CC} = 5V$	3.5			V
		$V_{CC} = 10V$	80			V
$V_{IN(0)}$	Logical "0" Input Voltage	$V_{CC} = 5V$			1.5	V
		$V_{CC} = 10V$			2.0	V
$V_{OUT(1)}$	Logical "1" Output Voltage	$V_{CC} = 5V$	4.5			V
		$V_{CC} = 10V$	9.0			V
$V_{OUT(0)}$	Logical "0" Output Voltage	$V_{CC} = 5V$			0.5	V
		$V_{CC} = 10V$			1.0	V
$I_{IN(1)}$	Logical "1" Input Current	$V_{CC} = 15V$			1.0	μA
$I_{IN(0)}$	Logical "0" Input Current	$V_{CC} = 15V$	-1.0			μA
I_{CC}	Supply Current	$V_{CC} = 15V$		0.05	60	μA

CMOS/LPTTL INTERFACE

$V_{IN(1)}$	Logical "1" Input Voltage	54C, $V_{CC} = 4.5V$ 74C, $V_{CC} = 4.75V$	$V_{CC} - 1.5$			
$V_{IN(0)}$	Logical "0" Input Voltage	54C, $V_{CC} = 4.75V$ 74C, $V_{CC} = 4.75V$			0.8	V
$V_{OUT(1)}$	Logical "1" Output Voltage	54C, $V_{CC} = 4.5V, I_D = -360 \mu A$ 74C, $V_{CC} = 4.75V, I_D = -360 \mu A$	2.4			V
$V_{OUT(0)}$	Logical "0" Output Voltage	54C, $V_{CC} = 4.5V, I_D = 360 \mu A$ 74C, $V_{CC} = 4.75V, I_D = 360 \mu A$			0.4	V

OUTPUT DRIVE (See 54C/74C Family Characteristics Data Sheet)

I_{SOURCE}	Output Source Current	$V_{CC} = 5V, V_{IN(0)} = 0V$ $T_A = 25^\circ C, V_{OUT} = 0V$	-1.75			mA
I_{SOURCE}	Output Source Current	$V_{CC} = 10V, V_{IN(0)} = 0V$ $T_A = 25^\circ C, V_{OUT} = 0V$	-8.0			mA
I_{SINK}	Output Sink Current	$V_{CC} = 5V, V_{IN(1)} = 5V$ $T_A = 25^\circ C, V_{OUT} = V_{CC}$	1.75			mA
I_{SINK}	Output Sink Current	$V_{CC} = 10V, V_{IN(1)} = 10V$ $T_A = 25^\circ C, V_{OUT} = V_{CC}$	8.0			mA

Note 1: "Absolute Maximum Ratings" are those values beyond which the safety of the device cannot be guaranteed. Except for "Operating Temperature Range" they are not meant to imply that the devices should be operated at these limits. The table of "Electrical Characteristics" provides conditions for actual device operation.

AC Electrical Characteristics* $T_A = 25^\circ\text{C}$, $C_L = 50\text{ pF}$, unless otherwise noted

Symbol	Parameter	Conditions	Min	Typ	Max	Units
C_{IN}	Input Capacitance	Any Input (Note 2)		5.0		pF
t_{pd}	Propagation Delay Time to a Logical "0" t_{pd0} or Logical "1" t_{pd1} from Clock to Q or \bar{Q}	$V_{CC} = 5\text{V}$ $V_{CC} = 10\text{V}$		180 70	300 110	ns ns
t_{pd}	Propagation Delay Time to a Logical "0" from Preset or Clear	$V_{CC} = 5\text{V}$ $V_{CC} = 10\text{V}$		180 70	300 110	ns ns
t_{pd}	Propagation Delay Time to a Logical "1" from Preset or Clear	$V_{CC} = 5\text{V}$ $V_{CC} = 10\text{V}$		250 100	400 150	ns ns
t_{s0} , t_{s1}	Time Prior to Clock Pulse that Data Must be Present t_{SETUP}	$V_{CC} = 5\text{V}$ $V_{CC} = 10\text{V}$	100 40	50 20		ns ns
t_{H0} , t_{H1}	Time after Clock Pulse that Data Must be Held	$V_{CC} = 5\text{V}$ $V_{CC} = 10\text{V}$		-20 -8.0	0 0	ns ns
t_{PW1}	Minimum Clock Pulse Width ($t_{WL} = t_{WH}$)	$V_{CC} = 5\text{V}$ $V_{CC} = 10\text{V}$		100 40	250 100	ns ns
t_{PW2}	Minimum Preset and Clear Pulse Width	$V_{CC} = 5\text{V}$ $V_{CC} = 10\text{V}$		100 40	160 70	ns ns
t_r , t_f	Maximum Clock Rise and Fall Time	$V_{CC} = 5\text{V}$ $V_{CC} = 10\text{V}$	15.0 5.0			μs μs
f_{MAX}	Maximum Clock Frequency	$V_{CC} = 5\text{V}$ $V_{CC} = 10\text{V}$	2.0 5.0	3.5 8.0		MHz MHz
C_{PD}	Power Dissipation Capacitance	(Note 3)		40		pF

*AC Parameters are guaranteed by DC correlated testing.

Note 1: "Absolute Maximum Ratings" are those values beyond which the safety of the device cannot be guaranteed. Except for "Operating Temperature Range" they are not meant to imply that the devices should be operated at these limits. The table of "Electrical Characteristics" provides conditions for actual device operation.

Note 2: Capacitance is guaranteed by periodic testing.

Note 3: C_{PD} determines the no load AC power consumption of any CMOS device. For complete explanation see 54C/74C Family Characteristics Application Note—AN-80.

Switching Time Waveform

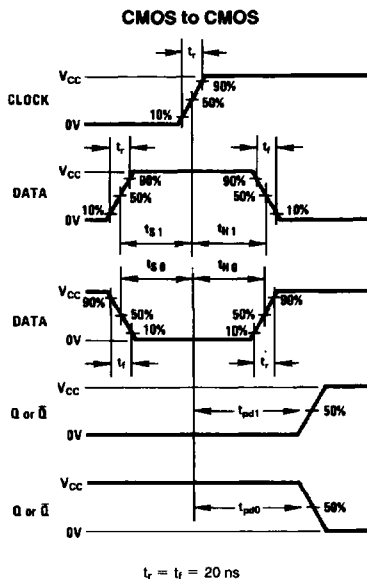

TL/F/5885-3

AC Test Circuit

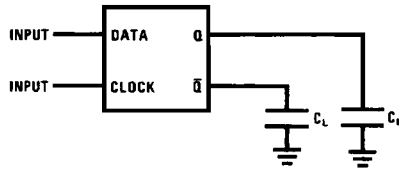

TL/F/5885-4

Typical Applications

Ripple Counter (Divide by 2^n)

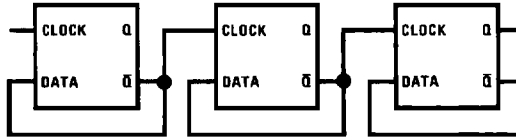

TL/F/5885-5

Shift Register

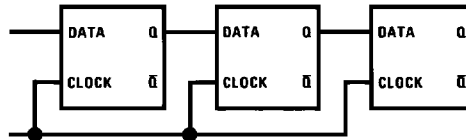

TL/F/5885-6

74C Compatibility

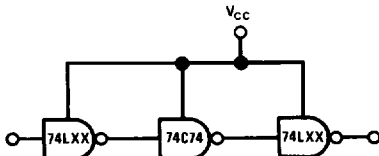

TL/F/5885-7

Guaranteed Noise Margin as a Function of V_{CC}

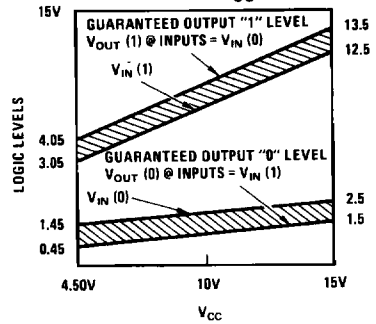

TL/F/5885-8