

FEATURES

- EIA STANDARD SIZING 0201, 0402, 0603, 0805, 1206, 1210, 2010 AND 2512
- SUIT FOR HIGH RELIABILITY APPLICATIONS IN HARSH ENVIRONMENTS
- AEC-Q200 QUALIFIED OPTION AVAILABLE (SEE PAGE 3 FOR AUTOMOTIVE PART NUMBERING SYSTEM)
- AVAILABLE IN STANDARD AND HIGH POWER RATINGS
- SAC REFLOW SOLDERABLE (THREE TIMES AT 260°C FOR 10 SECONDS)

**RoHS
Compliant**
includes all homogeneous materials

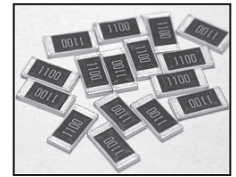

*See Part Number System for Details

STANDARD POWER SPECIFICATIONS

Type	EIA Size	Power Rating at 70°C	Max. *1 Working Voltage	Max. *2 Overload Voltage	Resistance Tolerance Code	Temperature Coefficient (ppm/°C)	Resistance Range (Ω)*3	Resistance Values	Operating Temperature Range
NRC-AS02	0201	0.05W	25V	50V	±1%(F), ±5%(J)	±200ppm	1 ~ 10M	E-24 & 96	-55°C ~ +125°C
NRC-AS04	0402	0.063W	50V	100V	±0.5%(D), ±1%(F), ±5%(J)	±100ppm	10 ~ 1M	E-24 & 96	-55°C ~ +155°C
						±200ppm	1 ~ 9.76 1.02M ~ 10M		
NRC-AS06	0603	0.10W	75V	100V	±0.5%(D), ±1%(F), ±5%(J)	±100ppm	10 ~ 1M	E-24 & 96	
						±200ppm	1 ~ 9.76 1.02M ~ 10M		
NRC-AS10	0805	0.125W	150V	300V	±0.5%(D), ±1%(F), ±5%(J)	±100ppm	10 ~ 1M	E-24 & 96	
						±200ppm	1 ~ 9.76 1.02M ~ 10M		
NRC-AS12	1206	0.25W	200V	400V	±0.5%(D), ±1%(F), ±5%(J)	±100ppm	10 ~ 1M	E-24 & 96	
						±200ppm	1 ~ 9.76 1.02M ~ 10M		
NRC-AS25	1210	0.33W	200V	400V	±0.5%(D), ±1%(F), ±5%(J)	±100ppm	10 ~ 1M	E-24 & 96	
						±200ppm	1 ~ 9.76 1.02M ~ 10M		
NRC-AS50	2010	0.75W	200V	400V	±0.5%(D), ±1%(F), ±5%(J)	±100ppm	10 ~ 1M	E-24 & 96	
						±200ppm	1 ~ 9.76 1.02M ~ 10M		
NRC-AS100	2512	1.0W	250V	500V	±0.5%(D), ±1%(F), ±5%(J)	±100ppm	10 ~ 1M	E-24 & 96	
						±200ppm	1 ~ 9.76 1.02M ~ 10M		

HIGH POWER SPECIFICATIONS

Type	EIA Size	Power Rating at 70°C	Max. *1 Working Voltage	Max. *2 Overload Voltage	Resistance Tolerance Code	Temperature Coefficient (ppm/°C)	Resistance Range (Ω)*3	Resistance Values	Operating Temperature Range
NRC-AS02P	0201	0.083W	25V	50V	±1%(F), ±5%(J)	±200ppm	10 ~ 1M	E-24 & 96	-55°C ~ +125°C
NRC-AS04P	0402	0.10W	50V	100V	±1%(F), ±5%(J)	±100ppm	10 ~ 1M	E-24 & 96	-55°C ~ +155°C
						±200ppm	1 ~ 9.76		
NRC-AS06P	0603	0.25W	75V	150V	±1%(F), ±5%(J)	±100ppm	10 ~ 1M	E-24 & 96	
						±200ppm	1 ~ 9.76		
NRC-AS10P	0805	0.33W	150V	300V	±1%(F), ±5%(J)	±100ppm	10 ~ 1M	E-24 & 96	
						±200ppm	1 ~ 9.76		
NRC-AS12P	1206	0.33W	200V	400V	±1%(F), ±5%(J)	±100ppm	10 ~ 1M	E-24 & 96	
						±200ppm	1 ~ 9.76		
NRC-AS25P	1210	0.50W	200V	400V	±1%(F), ±5%(J)	±100ppm	10 ~ 1M	E-24 & 96	
						±200ppm	1 ~ 9.76		
NRC-AS50P	2010	1.0W	200V	400V	±1%(F), ±5%(J)	±100ppm	10 ~ 1M	E-24 & 96	
						±200ppm	1 ~ 9.76		



Note *1 - Maximum allowable continuous Working Voltage for all resistors is the lower of the two values:

"Maximum Working Voltage" as specified above or the result of the following formula

$$\sqrt{\text{Power rating (Watts)} \times \text{Resistance (Ohms)}}$$

Note *2 - "Maximum Overload Voltage" for all resistors is the lower of the two values:

"Maximum Overload Voltage" as specified above or 2x the result of the following formula

$$\sqrt{\text{Power rating (Watts)} \times \text{Resistance (Ohms)}}$$

Power Derating Curve: For operation above 70°C, power rating must be derated according to the following chart:

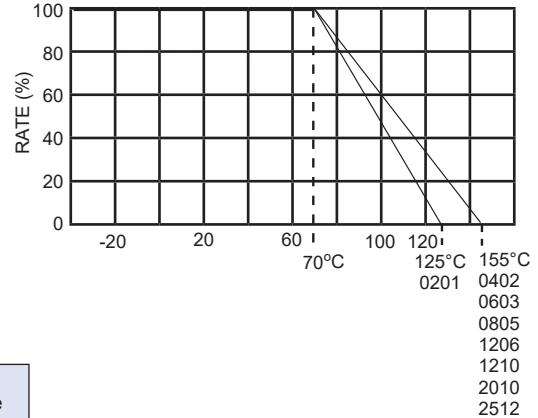

ZERO OHM JUMPERS*

Part Number	EIA Size	Max. Current at 70°C	Max. Resistance	Operating Temperature Range
NRC-AS02ZOTRF	0201	1A	<50mΩ	-55°C ~ +125°C
NRC-AS04ZOTRF	0402	1A	<50mΩ	
NRC-AS06ZOTRF	0603	1A	<50mΩ	
NRC-AS10ZOTRF	0805	2A	<50mΩ	
NRC-AS12ZOTRF	1206	2A	<50mΩ	
NRC-AS25ZOTRF	1210	2.5A	<50mΩ	
NRC-AS50ZOTRF	2010	3.5A	<50mΩ	-55°C ~ +155°C
NRC-AS100ZOTRF	2512	4A	<50mΩ	

*Optional AEC Q-200 Qualified "TRQYF" is also available

DIMENSIONS (mm)

Type	EIA Size	L	W	H	T	t
NRC-AS02	0201	0.60 ± 0.03	0.30 ± 0.03	0.23 ± 0.03	0.15 ± 0.05	0.15 ± 0.05
NRC-AS04	0402	1.00 ± 0.05	0.50 ± 0.05	0.35 ± 0.05	0.20 ± 0.10	0.20 ± 0.10
NRC-AS06	0603	1.60 ± 0.10	0.80 ± 0.10	0.45 ± 0.10	0.30 ± 0.20	0.30 ± 0.20
NRC-AS10	0805	2.00 ± 0.10	1.25 ± 0.10	0.50 ± 0.10	0.35 ± 0.20	0.40 ± 0.20
NRC-AS12	1206	3.10 ± 0.10	1.55 ± 0.10	0.55 ± 0.10	0.50 ± 0.25	0.50 ± 0.20
NRC-AS25	1210	3.10 ± 0.10	2.60 ± 0.15	0.55 ± 0.10	0.50 ± 0.25	0.50 ± 0.20
NRC-AS50	2010	5.00 ± 0.10	2.50 ± 0.15	0.55 ± 0.10	0.60 ± 0.25	0.50 ± 0.20
NRC-AS100	2512	6.35 ± 0.10	3.10 ± 0.15	0.55 ± 0.10	0.60 ± 0.25	0.50 ± 0.20

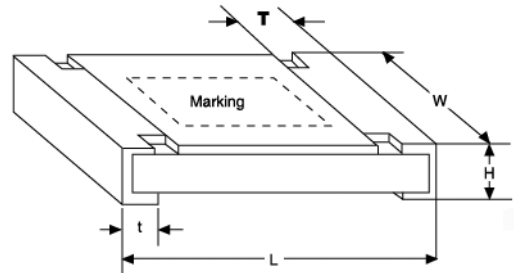

CONSTRUCTION

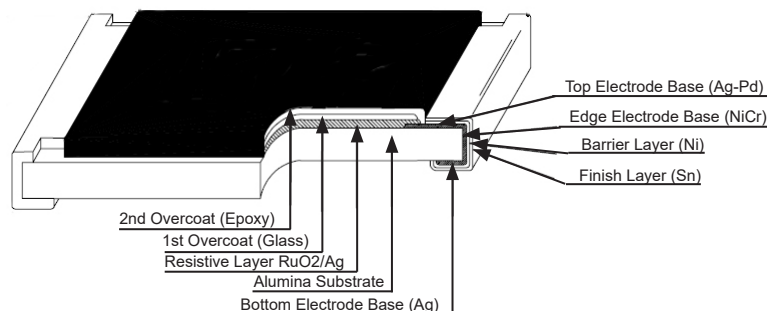

PART NUMBER SYSTEM

PART NUMBER SYSTEM (E-24 VALUES)

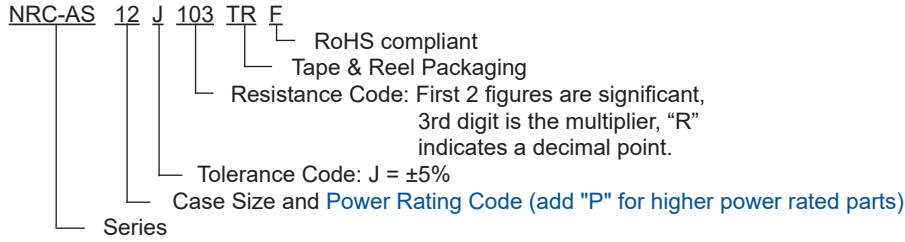

PART NUMBER SYSTEM (E-96 VALUES)

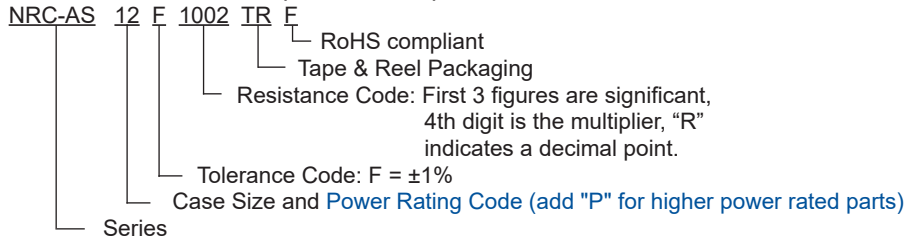

PART NUMBER SYSTEM - AUTOMOTIVE OPTION (Standard Power Ratings Only)

PART NUMBER SYSTEM (E-24 VALUES)

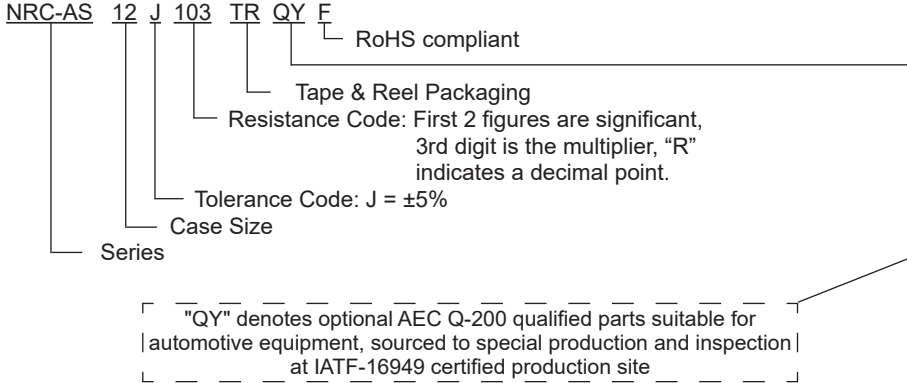

PART NUMBER SYSTEM (E-96 VALUES)

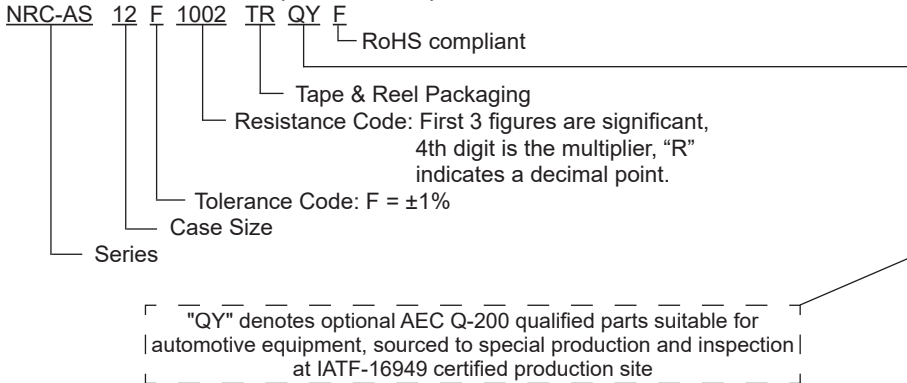

ENVIRONMENTAL CHARACTERISTICS (NON--AUTOMOTIVE)

Item	Specification			Test Method
	±0.5% & ±1% tolerance	±5% tolerance	Zero Ohm Jumper	
Temperature Coefficient of Resistance	As specified			-55°C ~ +125°C, +25°C reference point
Short Time Overload	ΔR ±1% +0.05Ω	ΔR ±2% +0.05Ω	<50mΩ	RCWV x 2.5 or Max Overloading Voltage for 5 Seconds
Insulation Resistance	>10GΩ			Maximum Overload Voltage for 1 Minute
Load Life	ΔR ±2% +0.10Ω	ΔR ±3% +0.10Ω	<100mΩ	Max. WV +70°C, 1.5 hours ON, 0.5 hours OFF Total time 1,000
Damp Heat (with load)	ΔR ±2% +0.10Ω	ΔR ±3% +0.10Ω	<100mΩ	+40°C, 90% ~ 95% RH, Max. WV 1.5 hours ON, 0.5 hours OFF Total time 1,000
Resistance to Dry Heat	ΔR ±1% +0.05Ω	ΔR ±1.5% +0.05Ω	<50mΩ	+125°C or +155°C for 1000 hours
Temperature Cycling	ΔR ±0.5% +0.05Ω	ΔR ±1% +0.05Ω	<50mΩ	-55°C to +125°C or +155°C, 5 cycles
Bending Strength	ΔR ±1% +0.05Ω	ΔR ±2% +0.05Ω	<50mΩ	Bending amplitude 3mm (2mm for 2010 & 2512) One bend for 5 seconds
Resistance to Soldering Heat	ΔR ±0.5% +0.05Ω	ΔR ±1% +0.05Ω	<50mΩ	260°C ±5°C for 10 seconds
Sulfur Test	ΔR ±0.5% +0.05Ω	ΔR ±0.5% +0.05Ω	<50mΩ	1,000ppm H ₂ S, +50°C ± 2°C, 91 ~ 93% RH for 1,000 hours (no power)
Leaching Test	Individual leaching are ≤ 5% Total leaching area ≤ 10%			+260°C for 30 seconds



ENVIRONMENTAL CHARACTERISTICS (AUTOMOTIVE GRADE PRODUCTS)

Item	Specification			Test Method
	±0.5% & ±1% tolerance	±5% tolerance	Zero Ohm Jumper	
Temperature Coefficient of Resistance	As specified			JIS C5201-1 4.8, IEC 60115-1 4.8 -55°C ~ +125°C, +25°C reference temperature
Short Time Overload	ΔR ±1% +0.05Ω	ΔR ±2% +0.05Ω	<50mΩ	JIS C5201-1 4.13, IEC 60115-1 4.13 RCWV x 2.5 or Max Overloading Voltage whichever is less for 5 Seconds
Insulation Resistance	>10GΩ			JIS C5201-1 4.6, IEC 60115-1 4.6 Maximum Overload Voltage for 1 Minute
Load Life	ΔR ±2% +0.10Ω	ΔR ±3% +0.10Ω	<100mΩ	JIS C5201-1 4.25, IEC 60115-1 4.25.1, MIL-STD-202, Method 108 Rated WV, +70°C, 1.5 hours ON, 0.5 hours OFF Total time 1,000 hours
Biased Humidity	ΔR ±2% +0.10Ω	ΔR ±3% +0.10Ω	<100mΩ	MIL-STD-202, Method 103 1000 hours, +85°C/85% RH 10% of operating power
High Temperature Exposure	ΔR ±1% +0.05Ω	ΔR ±1.5% +0.05Ω	<50mΩ	MIL-STD-202, Method 108 +155°C for 1000 hours
Temperature Cycling	ΔR ±0.5% +0.05Ω	ΔR ±1.5% +0.05Ω	<50mΩ	JESD22 Method JA-104 -55°C to +125°C, 1000 cycles
Bending Strength	ΔR ±1% +0.05Ω	ΔR ±1% +0.05Ω	<50mΩ	AEC-Q200-005 Bending amplitude 3mm (2mm for 2010 & 2512) One bend for 60 seconds
Resistance to Solvents	No visible damage of appearance and marking			MIL-STD-202, Method 215 Add aqueous wash chemical (OKEM clean or equivalent). Do not use banned solvents
Terminal Strength	No broken terminals			AEC-Q200-006 Force of 1.8kg for 60 seconds
Solderability	>95% Coverage			JIS C5201-1 4.17, IEC 60115-1 4.17, J-STD-002 +245°C ±5°C for 3 seconds
Resistance to Soldering Heat	ΔR ±0.5% +0.05Ω	ΔR ±1% +0.05Ω	<50mΩ	MIL-STD-202, Method 210 260°C ±5°C for 10 seconds
Voltage Proof	No breakdown or flashover			JIS C5201-1 4.7, IEC 60115-1 4.7 1.42 times maximum operating voltage for 1 minute
Flammability	No ignition of the tissue paper or scorching of the pinewood board			UL-94 V-0 or V-1 are acceptable. Electrical test not required
Sulfur Test	ΔR ±0.5%		<50mΩ	ASTM-B-809-95 H2S, +50°C ± 2°C, 91 ~ 93% RH for 1,000 hours (no power)
Leaching Test	Individual leaching are ≤ 5% Total leaching area ≤ 10%			JIS C5201-1 4.18, IEC 60068-2-58 8.2.1 +260°C for 30 seconds
Mechanical Shock	ΔR ±0.25% +0.05Ω	ΔR ±1.0% +0.05Ω	<50mΩ	MIL-STD-202, Method 213 Wave Form: Tolerance for half sine wave pulse. Peak Value is 100g's. Normal duration (D) is 6.
Vibration	ΔR ±0.5% +0.05Ω	ΔR ±1.0% +0.05Ω	<50mΩ	MIL-STD-202, Method 204 5g's for 20 minutes, 12 cycles each of 3 orientations, 10 ~ 2000Hz
ESD	ΔR ±1.0% +0.05Ω		<50mΩ	AEC-Q200-002 Human body, 2KV



STANDARD E-24, E-96 VALUES AND 0603 RESISTANCE CODES

E-24	E-96							
Value	Value	Code	Value	Code	Value	Code	Value	Code
100	100	01	102	02	105	03	107	04
110	110	05	113	06	115	07	118	08
120	121	09	124	10	127	11	130	12
130	133	13	137	14	140	15	143	16
150	147	17	150	18	154	19	158	20
160	162	21	165	22	169	23	174	24
180	178	25	182	26	187	27	191	28
200	196	29	200	30	205	31	210	32
220	215	33	221	34	226	35	232	36
240	237	37	243	38	249	39	255	40
270	261	41	267	42	274	43	280	44
300	287	45	294	46	301	47	309	48
330	316	49	324	50	332	51	340	52
360	348	53	357	54	365	55	374	56
390	383	57	392	58	402	59	412	60
430	422	61	432	62	442	63	453	64
470	464	65	475	66	487	67	499	68
510	511	69	523	70	536	71	549	72
560	562	73	576	74	590	75	604	76
620	619	77	634	78	649	79	665	80
680	681	81	698	82	715	83	732	84
750	750	85	768	86	787	87	806	88
820	825	89	845	90	866	91	887	92
910	909	93	931	94	953	95	976	96

PAPER CARRIER TAPE DIMENSIONS (mm)

Type	EIA Case Size	A	B	W ± 0.20	E ± 0.10	F ± 0.05	P ₀ ± 0.10	P ₁ ± 0.05	P ₂ ± 0.05	φD ₀ ^{+0.1} / ₋₀	T
NRC-AS02	0201	0.38±0.05	0.68±0.05	8.0	1.75	3.50	4.00	2.00	2.00	1.50	0.42±0.20
NRC-AS04	0402	0.65±0.10	1.15±0.10	8.0	1.75	3.50	4.00	2.00	2.00	1.50	0.45±0.10
NRC-AS06	0603	1.10±0.10	1.90±0.10	8.0	1.75	3.50	4.00	4.00	2.00	1.50	0.70±0.10
NRC-AS10	0805	1.60±0.10	2.40±0.20	8.0	1.75	3.50	4.00	4.00	2.00	1.50	0.85±0.10
NRC-AS12	1206	1.90±0.10	3.50±0.20	8.0	1.75	3.50	4.00	4.00	2.00	1.50	0.85±0.10
NRC-AS25	1210	2.90±0.10	3.50±0.20	8.0	1.75	3.50	4.00	4.00	2.00	1.50	0.85±0.10

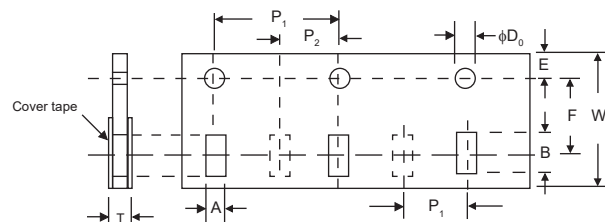

Type	EIA Case Size	A	B	W ± 0.30	E ± 0.10	F ± 0.05	P ₀ ± 0.10	P ₁ ± 0.05	P ₂ ± 0.05	φD ₀ ^{+0.1} / ₋₀	T max.
NRC-AS50	2010	2.8±0.10	5.5±0.10	12.0	1.75	5.50	4.00	4.00	2.00	1.50	1.2
NRC-AS100	2512	3.5±0.10	6.7±0.10	12.0	1.75	5.50	4.00	4.00	2.00	1.50	1.2

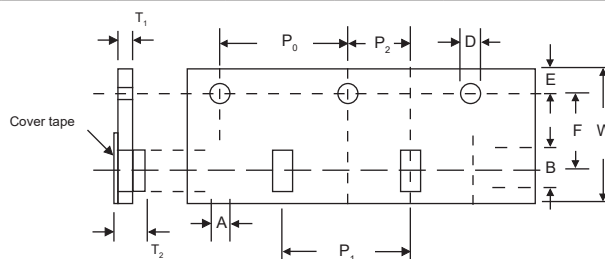

REEL DIMENSIONS (mm)

Type	EIA Case Size	Reel Quantity	Tape Width	Reel Diameter	ϕB	ϕC	W	T
NRC-AS02	0201	15,000	8mm	178.5 ± 1.5	60.0 +1/-0	13.0 ± 0.2	9.0 ± 0.5	12.5 ± 0.5
NRC-AS04	0402	10,000			100 ± 0.5		9.5 ± 0.5	13.5 ± 0.5
NRC-AS06	0603	5,000						
NRC-AS10	0805	5,000						
NRC-AS12	1206	5,000						
NRC-AS25	1210	5,000	12mm	178.5 ± 1.5	60.0 +1/-0	13.0 ± 0.5	13.0 ± 0.5	15.5 ± 0.5
NRC-AS50	2010	4,000						
NRC-AS100	2512	4,000						

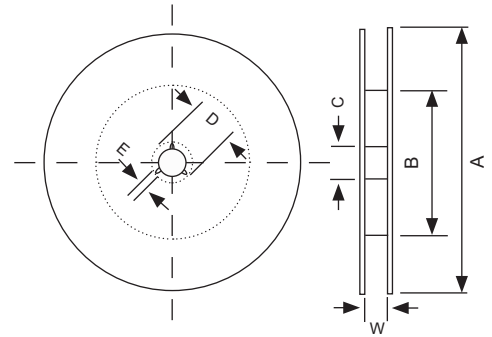

LAND PATTERN DIMENSIONS (mm)

Type	EIA Case Size	A	B	C
NRC-AS02	0201	0.30	0.25	0.30
NRC-AS04	0402	0.50	0.45	0.60
NRC-AS06	0603	0.90	0.60	0.90
NRC-AS10	0805	1.20	0.70	1.30
NRC-AS12	1206	2.00	0.90	1.60
NRC-AS25	1210	2.00	0.90	2.80
NRC-AS50	2010	3.80	0.90	2.80
NRC-AS100	2512	3.80	1.60	3.50

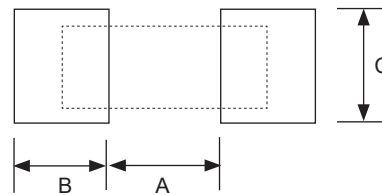

Reflow Soldering Heat Profile and Limits

→ www.niccomp.com/resource/files/resistive/NIC-ChipR-Reflow-Sept2020-Rev2.pdf

Wave soldering? – Please review your wave soldering process profile with NIC: tpmg@niccomp.com