

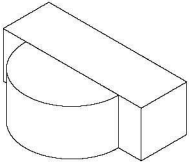

# RIGHT ANGLE SURFACE MOUNT INFRARED EMITTING DIODE

QTLP610CIR

## PACKAGE DIMENSIONS

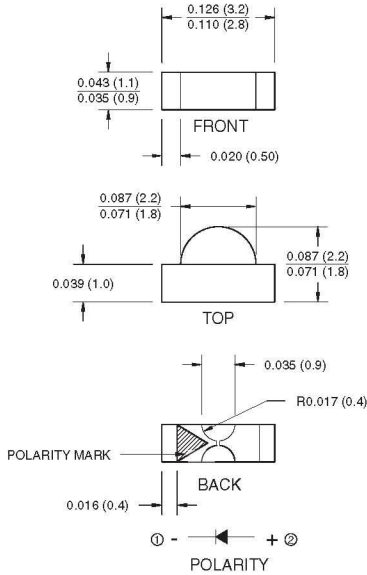

NOTE:  
1. Cathode  
2. Anode  
3. Dimensions for all drawings are in inches (mm).

## FEATURES

- Right Angle Surface Mount Package
- Available in 0.315" (8mm) width tape on 7" (178mm) diameter reel; 2,000 units per reel
- Wide Viewing Angle 160°
- Wavelength = 940 nm, GaAs
- Water Clear Lens
- Matched Photosensor: QTLP610CPD



# RIGHT ANGLE SURFACE MOUNT INFRARED EMITTING DIODE

## QTLP610CIR

### ABSOLUTE MAXIMUM RATINGS ( $T_A = 25^\circ\text{C}$ unless otherwise specified)

Parameter	Symbol	Rating	Unit
Operating Temperature	$T_{OPR}$	-40 to +85	$^\circ\text{C}$
Storage Temperature	$T_{STG}$	-40 to +90	$^\circ\text{C}$
Soldering Temperature (Iron) <sup>(1,2,3)</sup>	$T_{SOL-I}$	240 for 5 sec	$^\circ\text{C}$
Soldering Temperature (Flow) <sup>(1,2)</sup>	$T_{SOL-F}$	260 for 10 sec	$^\circ\text{C}$
Continuous Forward Current	$I_F$	65	mA
Reverse Voltage	$V_R$	5	V
Power Dissipation <sup>(4)</sup>	$P_D$	100	mW
Peak Forward Current (Pulse width = 100 $\mu\text{s}$ , Duty Cycle=1%)	$I_{FD}$	1.0	A

Notes:

1. RMA flux is recommended.
2. Methanol or isopropyl alcohols are recommended as cleaning agents.
3. Soldering iron tip at 1/16" (1.6mm) from housing
4. At 25 $^\circ\text{C}$  or below

### ELECTRICAL / OPTICAL CHARACTERISTICS ( $T_A = 25^\circ\text{C}$ )

PARAMETER	TEST CONDITIONS	SYMBOL	MIN.	TYP.	MAX.	UNITS
Peak Emission Wavelength	$I_F = 20\text{ mA}$	$\lambda_P$	—	940	—	nm
Emission Angle	$I_F = 20\text{ mA}$	$\Theta$	—	$\pm 80$	—	Deg.
Forward Voltage	$I_F = 20\text{ mA}$	$V_F$	—	1.2	1.5	V
	$I_F = 100\text{ mA}$ , $t_p = 100\ \mu\text{s}$ , Duty Cycle = 0.01		—	1.4	1.85	
	$I_F = 1\text{ A}$ , $t_p = 100\ \mu\text{s}$ , Duty Cycle = 0.01		—	2.6	4.0	
Reverse Current	$V_R = 5\text{ V}$	$I_R$	—	—	10	$\mu\text{A}$
Radiant Intensity	$I_F = 20\text{ mA}$	Ee	0.5	0.8	—	mW/sr
	$I_F = 100\text{ mA}$ , $t_p = 100\ \mu\text{s}$ , Duty Cycle = 0.01		—	4.0	—	
	$I_F = 1\text{ A}$ , $t_p = 100\ \mu\text{s}$ , Duty Cycle = 0.01		—	40	—	
Rise Time	$I_F = 100\text{ mA}$	$t_r$	—	1	—	$\mu\text{s}$
Fall Time	$t_p = 20\text{ ms}$	$t_f$	—	1	—	$\mu\text{s}$



# RIGHT ANGLE SURFACE MOUNT INFRARED EMITTING DIODE

## QTLP610CIR

### TYPICAL PERFORMANCE CURVES

**Fig. 1 Forward Current vs. Ambient Temperature**

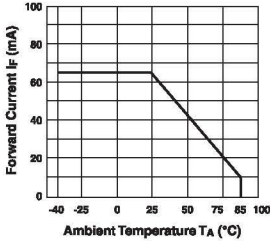

**Fig. 2 Relative Radiant Intensity vs. Wavelength**

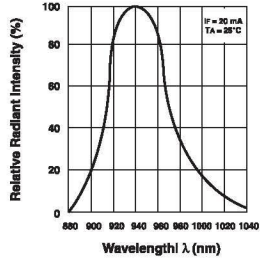

**Fig. 3 Peak Emission Wavelength vs. Ambient Temperature**

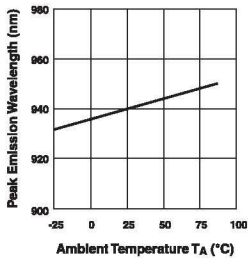

**Fig. 4 Forward Current vs. Forward Voltage**

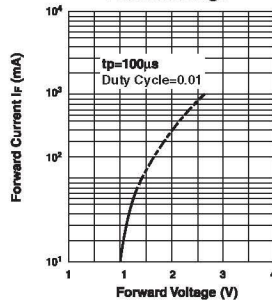

**Fig. 5 Relative Intensity vs. Ambient Temperature (°C)**

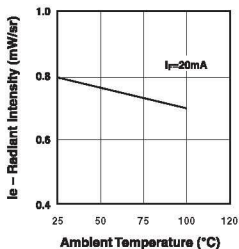

**Fig. 6 Relative Radiant Intensity vs. Angular Displacement**

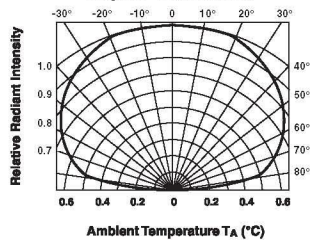



# RIGHT ANGLE SURFACE MOUNT INFRARED EMITTING DIODE

QTLP610CIR

## RECOMMENDED PRINTED CIRCUIT BOARD PATTERN

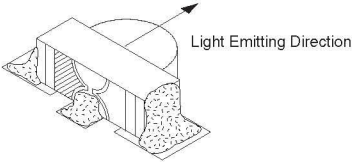
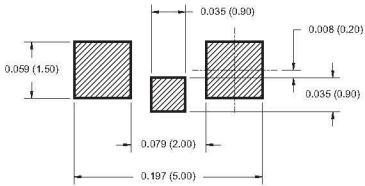

Mounting Example

## RECOMMENDED IR REFLOW SOLDERING PROFILE

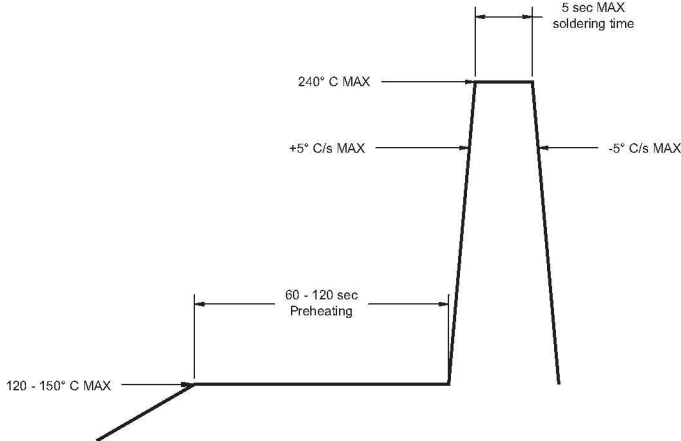





# RIGHT ANGLE SURFACE MOUNT INFRARED EMITTING DIODE

**QTLP610CIR**

## **DISCLAIMER**

FAIRCHILD SEMICONDUCTOR RESERVES THE RIGHT TO MAKE CHANGES WITHOUT FURTHER NOTICE TO ANY PRODUCTS HEREIN TO IMPROVE RELIABILITY, FUNCTION OR DESIGN. FAIRCHILD DOES NOT ASSUME ANY LIABILITY ARISING OUT OF THE APPLICATION OR USE OF ANY PRODUCT OR CIRCUIT DESCRIBED HEREIN; NEITHER DOES IT CONVEY ANY LICENSE UNDER ITS PATENT RIGHTS, NOR THE RIGHTS OF OTHERS.

## **LIFE SUPPORT POLICY**

FAIRCHILD'S PRODUCTS ARE NOT AUTHORIZED FOR USE AS CRITICAL COMPONENTS IN LIFE SUPPORT DEVICES OR SYSTEMS WITHOUT THE EXPRESS WRITTEN APPROVAL OF THE PRESIDENT OF FAIRCHILD SEMICONDUCTOR CORPORATION. As used herein:

1. Life support devices or systems are devices or systems which, (a) are intended for surgical implant into the body, or (b) support or sustain life, and (c) whose failure to perform when properly used in accordance with instructions for use provided in the labeling, can be reasonably expected to result in a significant injury of the user.
2. A critical component in any component of a life support device or system whose failure to perform can be reasonably expected to cause the failure of the life support device or system, or to affect its safety or effectiveness.