

MB8116400A-50/-60/-70/-80

CMOS 4M x 4 BIT FAST PAGE MODE DYNAMIC RAM

PRELIMINARY

1

CMOS 4,194,304 x 4 BIT Fast Page Mode Dynamic RAM

The Fujitsu MB8116400A is a fully decoded CMOS Dynamic RAM (DRAM) that contains 16,777,216 memory cells accessible in 4-bit increments. The MB8116400A features a "fast page" mode of operation whereby high-speed random access of up to 1,024-bits of data within the same row can be selected. The MB8116400A DRAM is ideally suited for mainframe, buffers, hand-held computers video imaging equipment, and other memory applications where very low power dissipation and high bandwidth are basic requirements of the design. Since the standby current of the MB8116400A is very small, the device can be used as a non-volatile memory in equipment that uses batteries for primary and/or auxiliary power.

The MB8116400A is fabricated using silicon gate CMOS and Fujitsu's advanced four-layer polysilicon and two-layer aluminum process. This process, coupled with advanced stacked capacitor memory cells, reduces the possibility of soft errors and extends the time interval between memory refreshes. Clock timing requirements for the MB8116400A are not critical and all inputs are TTL compatible.

PRODUCT LINE & FEATURES

Parameter	MB8116400A-50	MB8116400A-60	MB8116400A-70	MB8116400A-80
RAS Access Time	50ns max.	60ns max.	70ns max.	80ns max.
Random Cycle Time	90ns min.	110ns min.	130ns min.	150ns min.
Address Access Time	25ns min.	30ns max.	35ns max.	40ns max.
CAS Access Time	13ns max.	15ns max.	17ns max.	20ns max.
Fast Page Mode Cycle Time	35ns min.	40ns min.	45ns min.	50ns min.
Low Power Dissipation	550mW max.	467.5mW max.	385mW max.	330mW max.
• Operating current				
• Standby current				
	11mW max. (TTL level) / 5.5mW max. (CMOS level)			

- 4,194,304 words x 4 bit organization
- Silicon gate, CMOS, Advanced Capacitor Cell
- All input and output are TTL compatible
- 4096 refresh cycles every 65.6ms
- Early write or OE controlled write capability
- RAS only, CAS-before-RAS, or Hidden Refresh
- Fast page Mode, Read-Modify-Write capability
- On chip substrate bias generator for high performance

ABSOLUTE MAXIMUM RATINGS (see NOTE)

Parameter	Symbol	Value	Unit
Voltage at any pin relative to VSS	V_{IN}, V_{OUT}	-1 to +7	V
Voltage of V_{CC} supply relative to VSS	V_{CC}	-1 to +7	V
Power Dissipation	PD	1.0	W
Short Circuit Output Current	--	50	mA
Operating Temperature	T_{OPE}	0 to 70	°C
Storage Temperature	T_{STG}	-55 to +125	°C

NOTE: Permanent device damage may occur if the above **Absolute Maximum Ratings** are exceeded. Functional operation should be restricted to the conditions as detailed in the operational sections of this data sheet. Exposure to absolute maximum rating conditions for extended periods may affect device reliability.

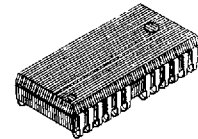

Plastic SOJ Package (LCC-26P-M09)

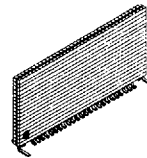

Plastic SVP Package (SVP-24P-M01)

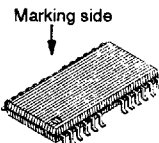

Plastic TSOP Packages (FPT-26P-M05) (Normal Bend) (Reverse Bend)

Package and Ordering Information

- 26-pin plastic (300mil) SOJ, order as MB8116400A-xxPJ
- 24-pin plastic (9.8 x 20mm) SVP, order as MB8116400A-xxPV
- 26-pin plastic (300mil) TSOP-II with normal bend leads, order as MB8116400A-xxPFTN
- 26-pin plastic (300mil) TSOP-II with reverse bend leads, order as MB8116400A-xxPFTR

This device contains circuitry to protect the inputs against damage due to high static voltages or electric fields. However, it is advised that normal precautions be taken to avoid application of any voltage higher than maximum rated voltages to this high impedance circuit.

Fig. 1 - MB8116400A DYNAMIC RAM - BLOCK DIAGRAM

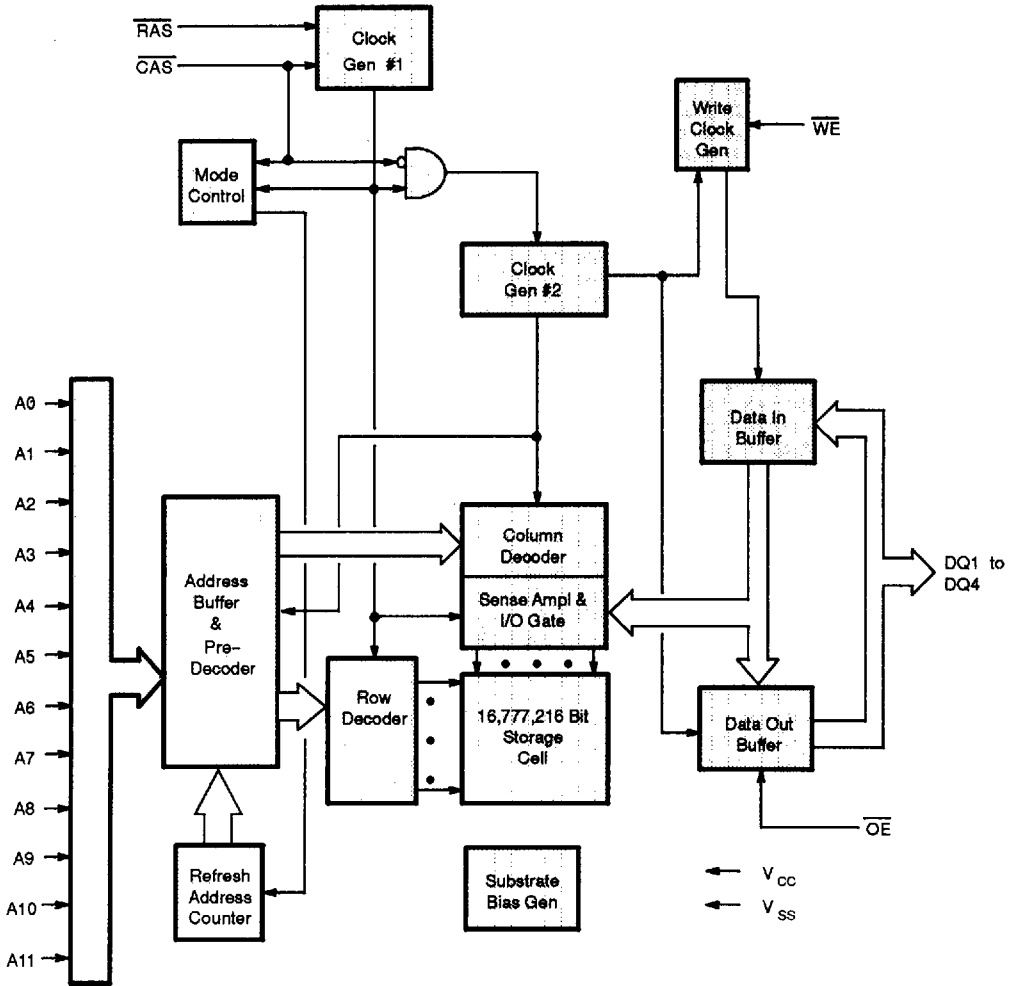

CAPACITANCE ($T_A = 25^\circ\text{C}$, $f = 1\text{MHz}$)

Parameter	Symbol	Typ	Max	Unit
Input Capacitance, A0 to A11	C_{IN1}	—	7	pF
Input Capacitance, $\overline{\text{RAS}}$, $\overline{\text{CAS}}$, $\overline{\text{WE}}$, $\overline{\text{OE}}$	C_{IN2}	—	7	pF
Input/Output Capacitance, DQ1 to DQ4	C_{DQ}	—	9	pF

PIN ASSIGNMENTS AND DESCRIPTIONS

26/24-Pin SOJ :
(TOP VIEW)

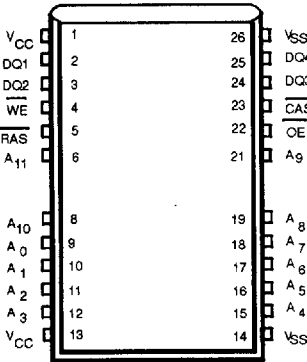

26/24-Pin FPT
(TOP VIEW)

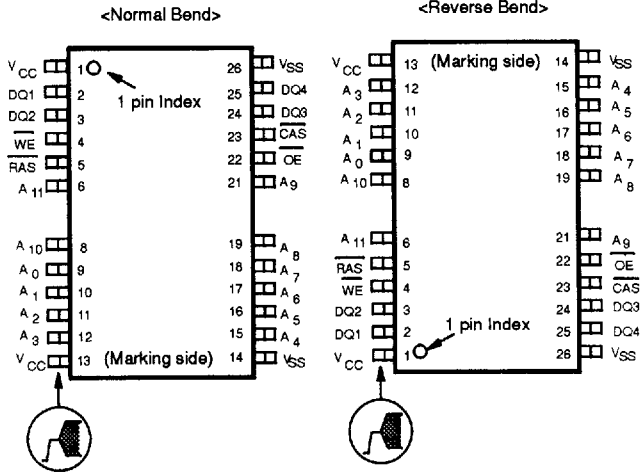

1

24-Pin SVP :
(TOP VIEW)

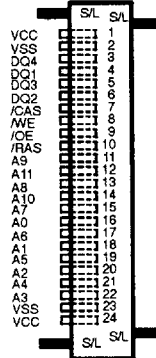

SL : Support Lead for vertical type

Designator	Function
DQ1 to DQ4	Data Input/ Output
WE	Write Enable.
RAS	Row address strobe.
A0 to A11	Address inputs.
VCC	+5 volt power supply.
OE	Output enable.
CAS	Column address strobe.
VSS	Circuit ground.

RECOMMENDED OPERATING CONDITIONS

Parameter	Notes	Symbol	Min	Typ	Max	Unit	Ambient Operating Temp
Supply Voltage	1	V _{CC}	4.5	5.0	5.5	V	0 °C to +70 °C
		V _{SS}	0	0	0		
Input High Voltage, all inputs	1	V _{IH}	2.4	—	6.5	V	
Input Low Voltage, all inputs/outputs *	1	V _{IL}	-0.3	—	0.8	V	

* : Undershoots of up to -2.0 volts with a pulse width not exceeding 20ns are acceptable.

FUNCTIONAL OPERATION

ADDRESS INPUTS

Twenty-four input bits are required to decode any four of 16,777,216 cell addresses in the memory matrix. Since only twelve address bits (A0 to A11) are available, the row and column inputs are separately strobed by $\overline{\text{RAS}}$ and $\overline{\text{CAS}}$ as shown in Figure 1. First, twelve row address bits are input on pins A0-through-A11 and latched with the row address strobe ($\overline{\text{RAS}}$) then, ten column address bits are input and latched with the column address strobe ($\overline{\text{CAS}}$). Both row and column addresses must be stable on or before the falling edge of $\overline{\text{RAS}}$ and $\overline{\text{CAS}}$, respectively. The address latches are of the flow-through type; thus, address information appearing after t_{RAH} (min)+ t_{r} is automatically treated as the column address.

WRITE ENABLE

The read or write mode is determined by the logic state of $\overline{\text{WE}}$. When $\overline{\text{WE}}$ is active Low, a write cycle is initiated; when $\overline{\text{WE}}$ is High, a read cycle is selected. During the read mode, input data is ignored.

DATA INPUT

Input data is written into memory in either of three basic ways--an early write cycle, an $\overline{\text{OE}}$ (delayed) write cycle, and a read-modify-write cycle. The falling edge of $\overline{\text{WE}}$ or $\overline{\text{CAS}}$, whichever is later, serves as the input data-latch strobe. In an early write cycle, the input data (DQ1-DQ4) is strobed by $\overline{\text{CAS}}$ and the setup/hold times are referenced to $\overline{\text{CAS}}$ because $\overline{\text{WE}}$ goes Low before $\overline{\text{CAS}}$. In a delayed write or a read-modify-write cycle, $\overline{\text{WE}}$ goes Low after $\overline{\text{CAS}}$; thus, input data is strobed by $\overline{\text{WE}}$ and all setup/hold times are referenced to the write-enable signal.

DATA OUTPUT

The three-state buffers are TTL compatible with a fanout of two TTL loads. Polarity of the output data is identical to that of the input; the output buffers remain in the high-impedance state until the column address strobe goes Low. When a read or read-modify-write cycle is executed, valid outputs are obtained under the following conditions:

- t_{TRAC} : from the falling edge of $\overline{\text{RAS}}$ when t_{RCD} (max) is satisfied.
- t_{TCAC} : from the falling edge of $\overline{\text{CAS}}$ when t_{RCD} is greater than t_{RCD} (max).
- t_{TAA} : from column address input when t_{TRAD} is greater than t_{TRAD} (max).
- t_{TOEA} : from the falling edge of $\overline{\text{OE}}$ when $\overline{\text{OE}}$ is brought Low after t_{TRAC}, t_{TCAC}, or t_{TAA}

The data remains valid until either $\overline{\text{CAS}}$ or $\overline{\text{OE}}$ returns to a High logic level. When an early write is executed, the output buffers remain in a high-impedance state during the entire cycle.

FAST PAGE MODE OF OPERATION

The fast page mode of operation provides faster memory access and lower power dissipation. The fast page mode is implemented by keeping the same row address and strobing in successive column addresses. To satisfy these conditions, $\overline{\text{RAS}}$ is held Low for all contiguous memory cycles in which row addresses are common. For each fast page of memory, any of 1,024-bits can be accessed and, when multiple MB 8116400As are used, $\overline{\text{CAS}}$ is decoded to select the desired memory fast page. Fast page mode operations need not be addressed sequentially and combinations of read, write, and/or read-modify-write cycles are permitted.

DC CHARACTERISTICS

(Recommended operating conditions unless otherwise noted)

Notes 3

Parameter	Notes	Symbol	Conditions	Values			Unit
				Min	Typ	Max	
Output high voltage		V_{OH}	$I_{OH} = -5 \text{ mA}$	2.4	—	—	V
Output low voltage		V_{OL}	$I_{OL} = 4.2 \text{ mA}$	—	—	0.4	
Input leakage current (any input)		$I_{I(L)}$	$0V \leq V_{IN} \leq 5.5V$; $4.5V \leq V_{CC} \leq 5.5V$; $V_{SS} = 0V$; All other pins under test = 0V	-10	—	10	μA
Output leakage current		$I_{O(L)}$	$0V \leq V_{OUT} \leq 5.5V$; Data out disabled	-10	—	10	
Operating current (Average power supply current) 2	MB8116400A-50	I_{CC1}	$\overline{\text{RAS}}$ & $\overline{\text{CAS}}$ cycling; $t_{RC} = \text{min}$	—	—	100	mA
	MB8116400A-60					85	
	MB8116400A-70					70	
	MB8116400A-80					60	
Standby current (Power supply current)	TTL level	I_{CC2}	$\overline{\text{RAS}} = \overline{\text{CAS}} = V_{IH}$	—	—	2.0	mA
	CMOS level		$\overline{\text{RAS}} = \overline{\text{CAS}} \geq V_{CC} - 0.2V$			1.0	
Refresh current #1 (Average power supply current) 2	MB8116400A-50	I_{CC3}	$\overline{\text{CAS}} = V_{IH}$, $\overline{\text{RAS}}$ cycling; $t_{RC} = \text{min}$	—	—	100	mA
	MB8116400A-60					85	
	MB8116400A-70					70	
	MB8116400A-80					60	
Fast Page Mode current 2	MB8116400A-50	I_{CC4}	$\overline{\text{RAS}} = V_{IL}$, $\overline{\text{CAS}}$ cycling; $t_{PC} = \text{min}$	—	—	100	mA
	MB8116400A-60					85	
	MB8116400A-70					70	
	MB8116400A-80					60	
Refresh current #2 (Average power supply current) 2	MB8116400A-50	I_{CC5}	$\overline{\text{RAS}}$ cycling; $\overline{\text{CAS}}$ -before- $\overline{\text{RAS}}$; $t_{RC} = \text{min}$	—	—	100	mA
	MB8116400A-60					85	
	MB8116400A-70					70	
	MB8116400A-80					60	

1

MB8116400A-50
 MB8116400A-60
 MB8116400A-70
 MB8116400A-80

AC CHARACTERISTICS

(At recommended operating conditions unless otherwise noted.) Notes 3, 4, 5

No.	Parameter	Notes	Symbol	MB8116400A-50		MB8116400A-60		MB8116400A-70		MB8116400A-80		Unit
				Min	Max	Min	Max	Min	Max	Min	Max	
1	Time Between Refresh		t_{REF}	—	65.6	—	65.6	—	65.6	—	65.6	ns
2	Random Read/Write Cycle Time		t_{RC}	90	—	110	—	130	—	150	—	ns
3	Read-Modify-Write Cycle Time		t_{RWC}	126	—	150	—	174	—	200	—	ns
4	Access Time from \overline{RAS}	6,9	t_{RAC}	—	50	—	60	—	70	—	80	ns
5	Access Time from \overline{CAS}	7,9	t_{CAC}	—	13	—	15	—	17	—	20	ns
6	Column Address Access Time	8,9	t_{AA}	—	25	—	30	—	35	—	40	ns
7	Output Hold Time		t_{OH}	3	—	3	—	3	—	3	—	ns
8	Output Buffer Turn On Delay Time		t_{ON}	0	—	0	—	0	—	0	—	ns
9	Output Buffer Turn off Delay Time	10	t_{OFF}	—	13	—	15	—	17	—	20	ns
10	Transition Time		t_T	3	50	3	50	3	50	3	50	ns
11	\overline{RAS} Precharge Time		t_{RP}	30	—	40	—	50	—	60	—	ns
12	\overline{RAS} Pulse Width		t_{RAS}	50	100000	60	100000	70	100000	80	100000	ns
13	\overline{RAS} Hold Time		t_{RSH}	13	—	15	—	17	—	20	—	ns
14	\overline{CAS} to \overline{RAS} Precharge Time		t_{CRP}	0	—	0	—	0	—	0	—	ns
15	\overline{RAS} to \overline{CAS} Delay Time	11,12	t_{RCD}	20	37	20	45	20	53	20	60	ns
16	\overline{CAS} Pulse Width		t_{CAS}	13	—	15	—	17	—	20	—	ns
17	\overline{CAS} Hold Time		t_{CSH}	50	—	60	—	70	—	80	—	ns
18	\overline{CAS} Precharge Time (Normal)	19	t_{CPN}	10	—	10	—	10	—	10	—	ns
19	Row Address Set Up Time		t_{ASR}	0	—	0	—	0	—	0	—	ns
20	Row Address Hold Time		t_{RAH}	10	—	10	—	10	—	10	—	ns
21	Column Address Set Up Time		t_{ASC}	0	—	0	—	0	—	0	—	ns
22	Column Address Hold Time		t_{CAH}	13	—	15	—	15	—	15	—	ns
23	Column Address Hold Time from \overline{RAS}		t_{AR}	35	—	35	—	35	—	35	—	ns
24	\overline{RAS} to Column Address Delay Time	13	t_{RAD}	15	25	15	30	15	35	15	40	ns
25	Column Address to \overline{RAS} Lead Time		t_{RAL}	25	—	30	—	35	—	40	—	ns
26	Column Address to \overline{CAS} Lead time		t_{CAL}	25	—	30	—	35	—	40	—	ns
27	Read Command Set Up Time		t_{RCS}	0	—	0	—	0	—	0	—	ns
28	Read Command Hold Time Referenced to \overline{RAS}	14	t_{RRH}	0	—	0	—	0	—	0	—	ns
29	Read Command Hold Time Referenced to \overline{CAS}	14	t_{RCH}	0	—	0	—	0	—	0	—	ns
30	Write Command Set Up Time	15	t_{WCS}	0	—	0	—	0	—	0	—	ns
31	Write Command Hold Time		t_{WCH}	15	—	15	—	15	—	15	—	ns
32	Write Hold Time from \overline{RAS}		t_{WCR}	35	—	35	—	35	—	35	—	ns
33	\overline{WE} Pulse Width		t_{WP}	15	—	15	—	15	—	15	—	ns
34	Write Command to \overline{RAS} Lead Time		t_{RWL}	13	—	15	—	17	—	20	—	ns
35	Write Command to \overline{CAS} Lead Time		t_{CWL}	13	—	15	—	17	—	20	—	ns

AC CHARACTERISTICS (Continued)

(At recommended operating conditions unless otherwise noted.) Notes 3, 4, 5

No.	Parameter	Notes	Symbol	MB8116400A-50		MB8116400A-60		MB8116400A-70		MB8116400A-80		Unit
				Min	Max	Min	Max	Min	Max	Min	Max	
36	DIN Set Up Time		t_{DS}	0	—	0	—	0	—	0	—	ns
37	DIN Hold Time		t_{DH}	15	—	15	—	15	—	15	—	ns
38	Data Hold Time from RAS		t_{DHR}	35	—	35	—	35	—	35	—	ns
39	RAS to WE Delay Time	20	t_{RWD}	68	—	80	—	92	—	105	—	ns
40	CAS to WE Delay Time	20	t_{CWD}	31	—	35	—	39	—	45	—	ns
41	Column Address to WE Delay Time	20	t_{AWD}	43	—	50	—	57	—	65	—	ns
42	RAS Precharge time to CAS Active Time (Refresh cycles)		t_{RPC}	5	—	5	—	5	—	5	—	ns
43	CAS Set Up Time for CAS-before-RAS Refresh		t_{CSR}	0	—	0	—	0	—	0	—	ns
44	CAS Hold Time for CAS-before-RAS Refresh		t_{CHR}	10	—	10	—	12	—	15	—	ns
45	WE Set Up Time from RAS		t_{WSR}	0	—	0	—	0	—	0	—	ns
46	WE Hold Time from RAS		t_{WHR}	10	—	10	—	10	—	10	—	ns
47	Access Time from OE	9	t_{OEA}	—	13	—	15	—	17	—	20	ns
48	Output Buffer Turn Off Delay from OE	10	t_{OEZ}	—	13	—	15	—	17	—	20	ns
49	OE to RAS Lead Time for Valid Data		t_{OEL}	5	—	5	—	7	—	10	—	ns
50	OE Hold Time Referenced to WE	16	t_{OEH}	5	—	5	—	5	—	5	—	ns
51	OE to Data In Delay Time		t_{OED}	13	—	15	—	17	—	20	—	ns
52	CAS to Data in Delay Time		t_{ODD}	—	13	—	15	—	17	—	20	ns
53	DIN to CAS Delay Time	17	t_{DZC}	0	—	0	—	0	—	0	—	ns
54	DIN to OE Delay Time	17	t_{DZO}	0	—	0	—	0	—	0	—	ns
55	Fast Page Mode RAS Pulse width		t_{RASP}	—	100000	—	100000	—	100000	—	100000	ns
60	Fast Page Mode Read/Write Cycle Time		t_{PC}	35	—	40	—	45	—	50	—	ns
61	Fast Page Mode Read-Modify-Write Cycle Time		t_{PRWC}	71	—	80	—	89	—	100	—	ns
62	Access Time from CAS Precharge	9,18	t_{CPA}	—	30	—	35	—	40	—	45	ns
63	Fast Page Mode CAS Precharge Time		t_{CP}	10	—	10	—	10	—	10	—	ns
64	Fast Page Mode RAS Hold Time from CAS Precharge		t_{RHCP}	30	—	35	—	40	—	45	—	ns
65	Fast Page Mode CAS Precharge to WE Delay Time		t_{CPWD}	48	—	55	—	62	—	70	—	ns

Notes:

1. Referenced to VSS.
2. ICC depends on the output load conditions and cycle rates. The specified values are obtained with the output open. ICC depends on the number of address change as $\overline{RAS1}$, $\overline{RAS2} = V_{IL}$, $\overline{CAS1}$, $\overline{CAS2} = V_{IH}$ and $V_{IL} > -0.3V$.
 ICC_1 , ICC_3 , ICC_4 and ICC_5 are specified at one time of address change during $\overline{RAS1}$, $\overline{RAS2} = V_{IL}$ and $\overline{CAS1}$, $\overline{CAS2} = V_{IH}$. ICC_2 is specified during $\overline{RAS} = V_{IH}$ and $V_{IL} > -0.3V$.
3. An initial pause ($\overline{RAS1}$, $\overline{RAS2} = \overline{CAS1}$, $\overline{CAS2} = V_{IH}$) of 200 μs is required after power-up followed by any eight \overline{RAS} -only cycles before proper device operation is achieved. In case of using internal refresh counter, a minimum of eight \overline{CAS} -before- \overline{RAS} initialization cycles instead of 8 $\overline{RAS1}$, $\overline{RAS2}$ cycles are required.
4. AC characteristics assume $t_r = 5ns$.
5. V_{IH} (min) and V_{IL} (max) are reference levels for measuring timing of input signals. Also transition times are measured between V_{IH} (min) and V_{IL} (max) as input amplitude are 3.0V and 0V..
6. Assumes that $t_{RCD} \leq t_{RCD} (max)$, $t_{RAD} \leq t_{RAD} (max)$. If t_{RCD} is greater than the maximum recommended value shown in this table, t_{RAC} will be increased by the amount that t_{RCD} exceeds the value shown. Refer to Fig. 2 and 3.
7. If $t_{RCD} \geq t_{RCD} (max)$, $t_{RAD} \geq t_{RAD} (max)$, and $t_{ASC} \geq t_{AA} - t_{CAC} - t_T$, access time is t_{CAC} .
8. If $t_{RAD} \geq t_{RAD} (max)$ and $t_{ASC} \leq t_{AA} - t_{CAC} - t_T$, access time is t_{AA} .
9. Measured with a load equivalent to two TTL loads and 100 pF.
10. t_{OFF} and t_{OEZ} is specified that output buffer change to high impedance state.
11. Operation within the $t_{RCD} (max)$ limit ensures that $t_{RAC} (max)$ can be met. $t_{RCD} (max)$ is specified as a reference point only; if t_{RCD} is greater than the specified $t_{RCD} (max)$ limit, access time is controlled exclusively by t_{CAC} or t_{AA} .
12. $t_{RCD} (min) = t_{RAH} (min) + 2t_T + t_{ASC} (min)$.
13. Operation within the $t_{RAD} (max)$ limit ensures that $t_{RAC} (max)$ can be met. $t_{RAD} (max)$ is specified as a reference point only; if t_{RAD} is greater than the specified $t_{RAD} (max)$ limit, access time is controlled exclusively by t_{CAC} or t_{AA} .
14. Either t_{RRH} or t_{RCH} must be satisfied for a read cycle.
15. t_{WCS} is specified as a reference point only. If $t_{WCS} \geq t_{WCS} (min)$ the data output pin will remain High-Z state through entire cycle.
16. Assumes that $t_{WCS} < t_{WCS} (min)$.
17. Either t_{DZC} or t_{DZO} must be satisfied.
18. t_{CPA} is access time from the selection of a new column address (that is caused by changing $\overline{CAS1}$, $\overline{CAS2}$ from "L" to "H"). Therefore, if t_{CP} is long, t_{CPA} is longer than $t_{CPA} (max)$.
19. Assumes that \overline{CAS} -before- \overline{RAS} refresh.
20. t_{WCS} , t_{CWD} , t_{RWD} and t_{AWD} are not restrictive operating parameters. They are included in the data sheet as an electrical characteristic only. If $t_{WCS} > t_{WCS} (min)$, the cycle is an early write cycle and Dout pin will maintain high impedance state throughout the entire cycle. If $t_{CWD} > t_{CWD} (min)$, $t_{RWD} > t_{RWD} (min)$, and $t_{AWD} > t_{AWD} (min)$, the cycle is a read modify-write cycle and data from the selected cell will appear at the Dout pin. If neither of the above conditions is satisfied, the cycle is a delayed write cycle and invalid data will appear the Dout pin, and write operation can be executed by satisfying t_{RWL} , t_{CWL} , and t_{RAL} specifications.

1

Fig. 2 - t_{RAC} vs. t_{RCD}

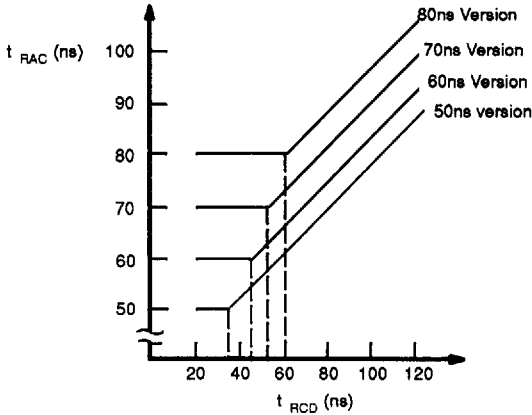
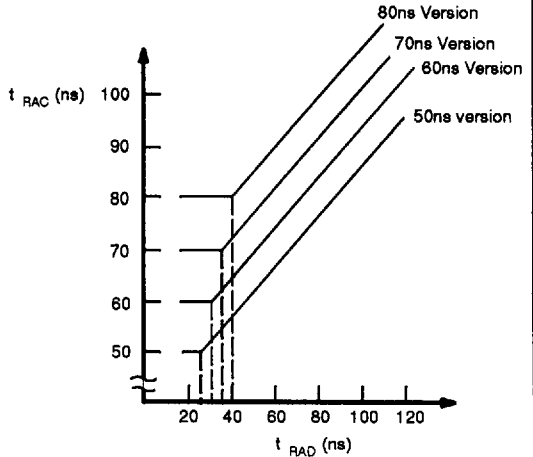

Fig. 3 - t_{RAC} vs. t_{RAD}



1

FUNCTIONAL TRUTH TABLE

Operation Mode	Clock Input				Address		Input Data		Refresh	Note
	RAS	CAS	WE	OE	Row	Column	Input	Output		
Standby	H	H	X	X	—	—	—	High-Z	—	
Read Cycle	L	L	H	L	Valid	Valid	—	Valid	Yes *	$t_{RCS} \geq t_{RCS}(\text{min})$
Write Cycle (Early Write)	L	L	L	X	Valid	Valid	Valid	High-Z	Yes *	$t_{WCS} \geq t_{WCS}(\text{min})$
Read-Modify- Write Cycle	L	L	H→L	L→H	Valid	Valid	Valid	Valid	Yes *	
RAS-only Refresh Cycle	L	H	X	X	Valid	—	—	High-Z	Yes	
CAS-before- RAS Refresh Cycle	L	L	H	X	—	—	—	High-Z	Yes	$t_{CSR} \geq t_{CSR}(\text{min})$
Hidden Refresh Cycle	H→L	L	H→X	L	—	—	—	Valid	Yes	Previous data is kept.

X; "H" or "L"

*; It is impossible in Fast Page Mode

Fig. 5 — EARLY WRITE CYCLE (\overline{OE} = "H" or "L")

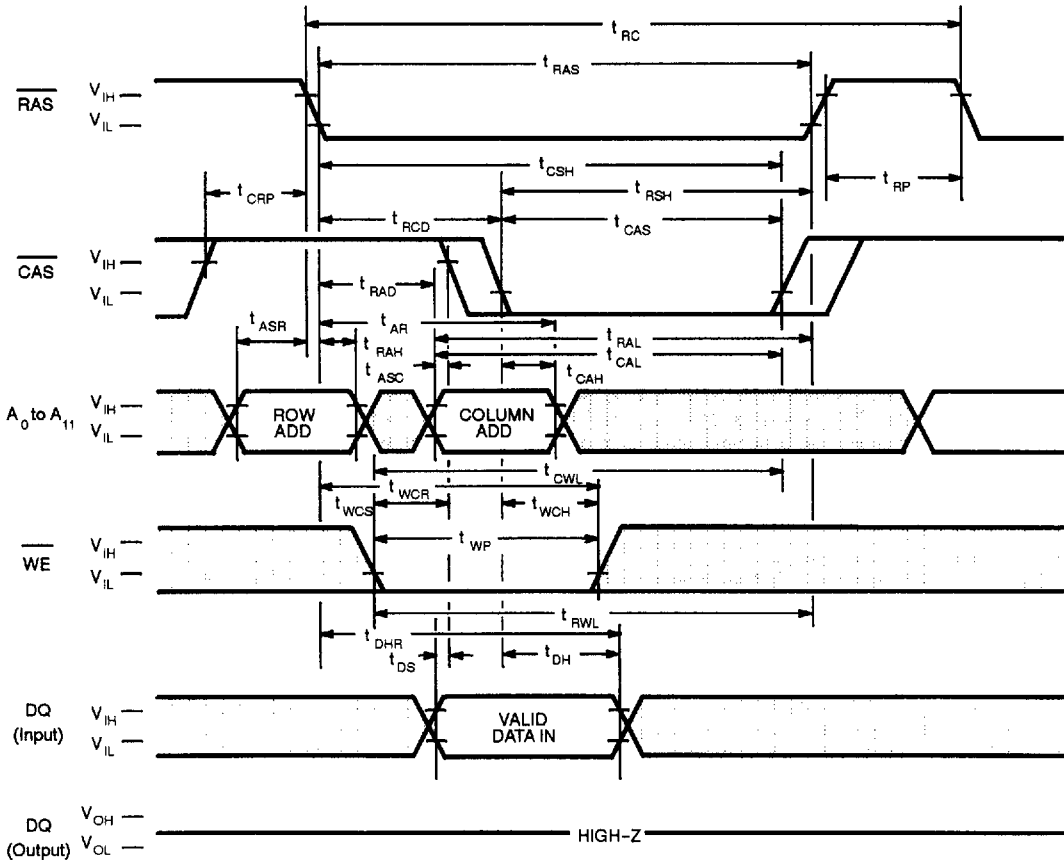

DESCRIPTION

A write cycle is similar to a read cycle except \overline{WE} is set to a Low state and \overline{OE} is a "H" or "L" signal. A write cycle can be implemented in either of three ways - early write, \overline{OE} write (delayed write), or read-modify-write. During all write cycles, timing parameters t_{RWL} , t_{CWL} and t_{RAL} must be satisfied. In the early write cycle shown above t_{WCS} satisfied, data on the DQ pin is latched with the falling edge of \overline{CAS} and written into memory.

Fig. 7 — READ-MODIFY-WRITE-CYCLE

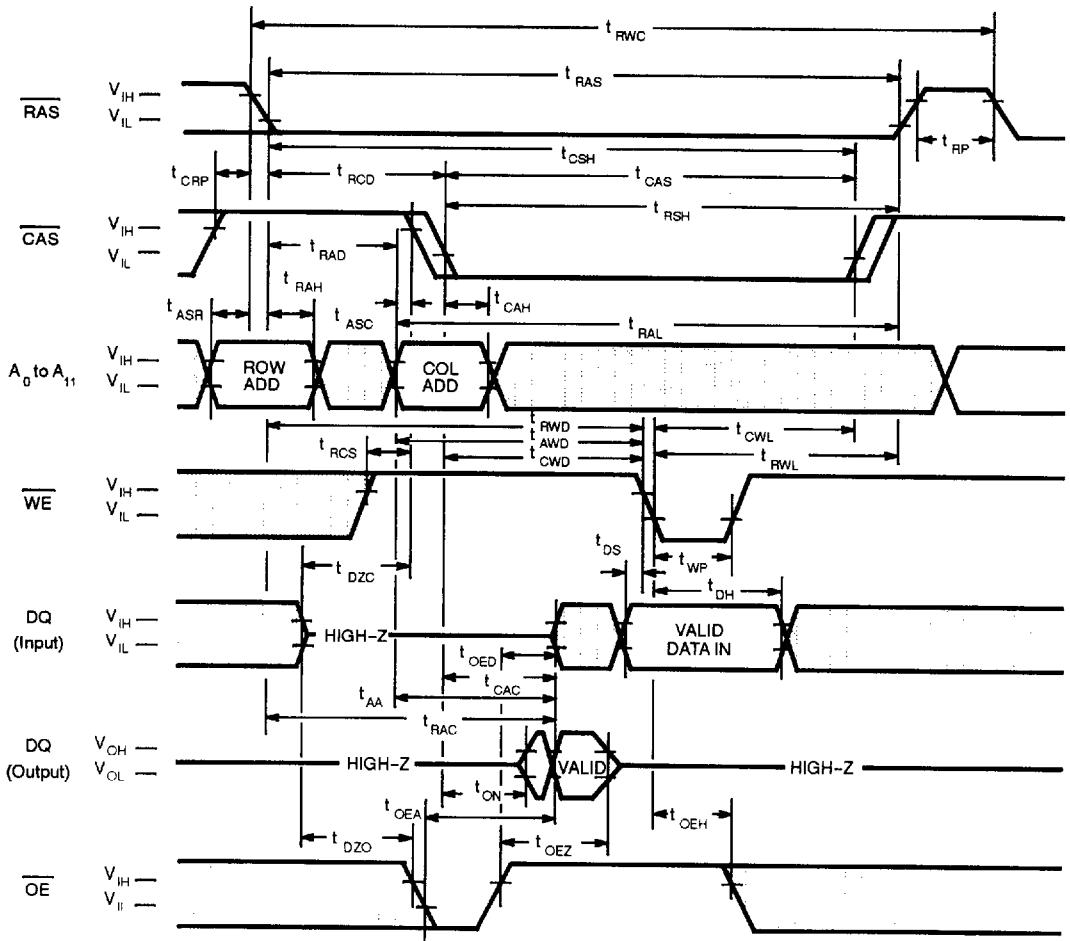

DESCRIPTION

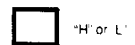

The read-modify-write cycle is executed by changing \overline{WE} from High to Low after the data appears on the DQ pins. In the read-modify-write cycle, \overline{OE} must be changed from Low to High after the memory access time.

1

Fig. 9 — FAST PAGE MODE WRITE CYCLE (\overline{OE} = "H" or "L")

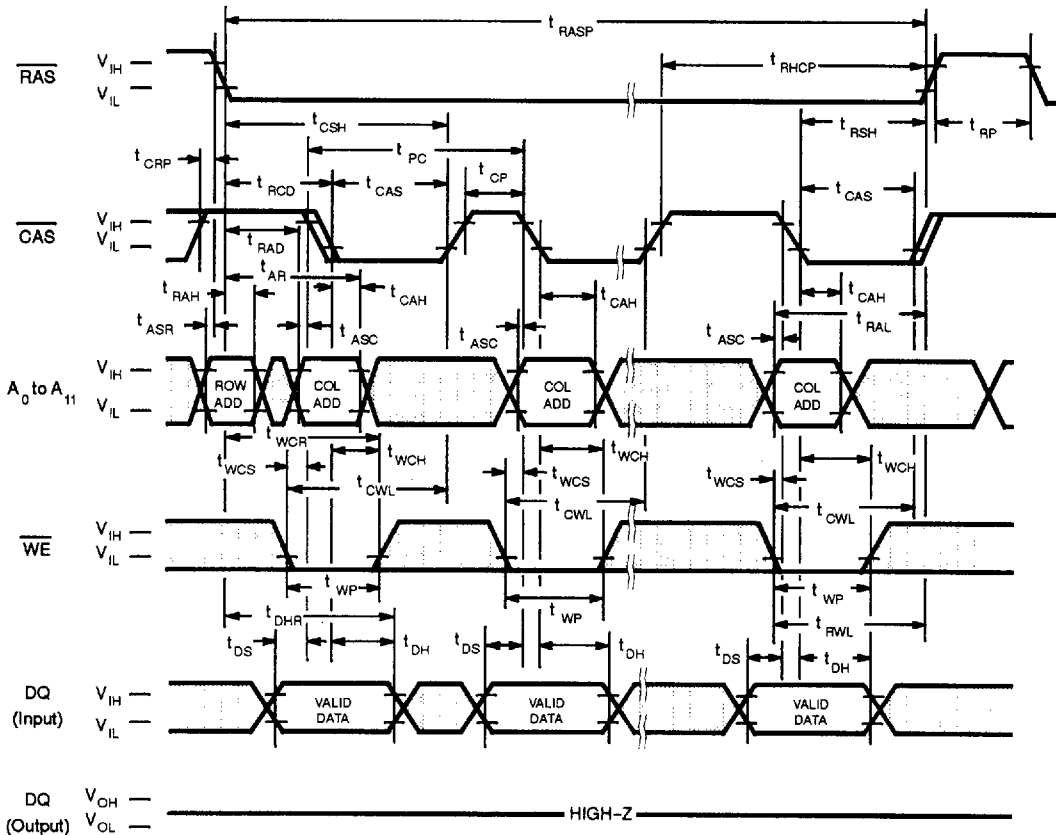

"H" or "L"

DESCRIPTION

The fast page mode write cycle is executed in the same manner as the fast page mode read cycle except the states of \overline{WE} and \overline{OE} are reversed. Data appearing on the DQ pins is latched on the falling edge of CAS and written into memory. During the fast page mode write cycle, including the delayed (\overline{OE}) write and read-modify-write cycles, t_{CWL} must be satisfied.

1

Fig. 10 — FAST PAGE MODE \overline{OE} WRITE CYCLE

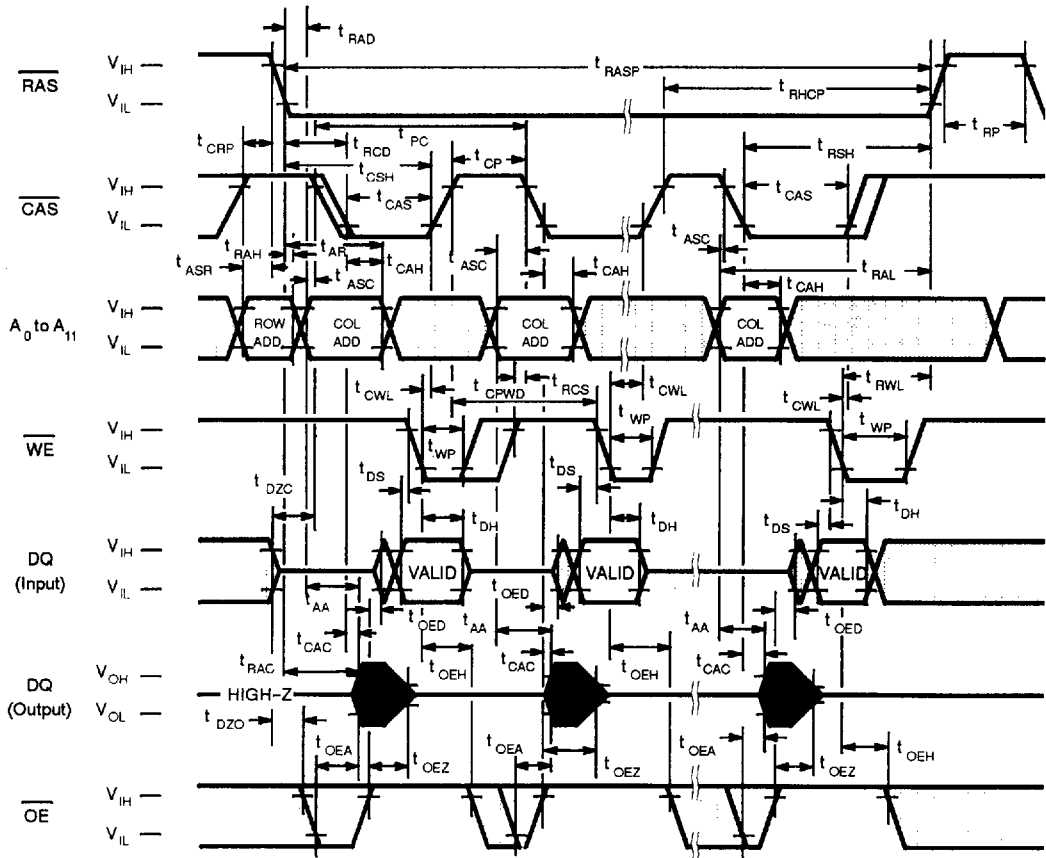

"H" or "L"
 Invalid Data

DESCRIPTION

The fast page mode \overline{OE} (delayed) write cycle is executed in the same manner as the fast page mode write cycle except for the states of \overline{WE} and \overline{OE} . Input data on the DQ pins are latched on the falling edge of \overline{WE} and written into memory. In the fast page mode delayed write cycle, \overline{OE} must be changed from Low to High before \overline{WE} goes Low ($t_{OED} + t_{DS}$).

Fig. 12 — $\overline{\text{RAS}}$ -ONLY REFRESH ($\overline{\text{WE}} = \overline{\text{OE}} = \text{"H" or "L"}$)

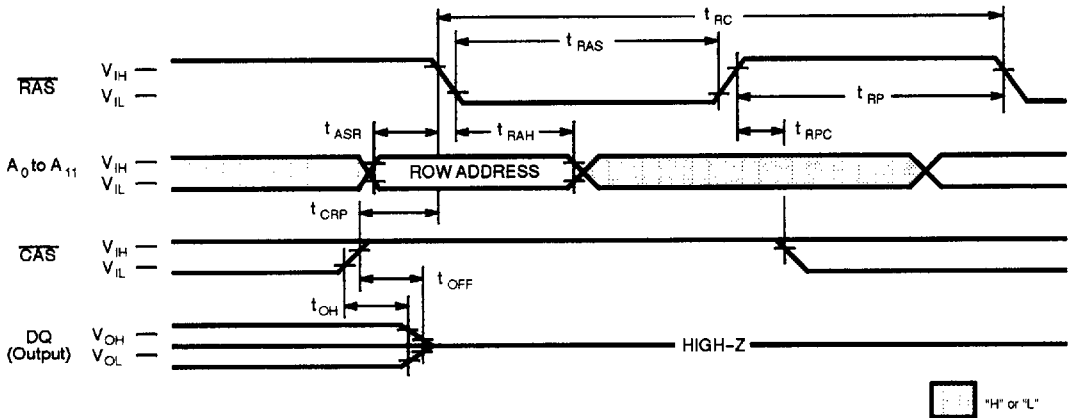

DESCRIPTION

Refresh of RAM memory cells is accomplished by performing a read, a write, or a read-modify-write cycle at each of 4096 row addresses every 65.6-milliseconds. Three refresh modes are available: $\overline{\text{RAS}}$ -only refresh, $\overline{\text{CAS}}$ -before- $\overline{\text{RAS}}$ refresh, and hidden refresh.

$\overline{\text{RAS}}$ -only refresh is performed by keeping $\overline{\text{RAS}}$ Low and $\overline{\text{CAS}}$ High throughout the cycle; the row address to be refreshed is latched on the falling edge of $\overline{\text{RAS}}$. During $\overline{\text{RAS}}$ -only refresh, DQ pin is kept in a high-impedance state.

Fig. 13 — $\overline{\text{CAS}}$ -BEFORE- $\overline{\text{RAS}}$ REFRESH (ADDRESSES = $\overline{\text{OE}} = \text{"H" or "L"}$)

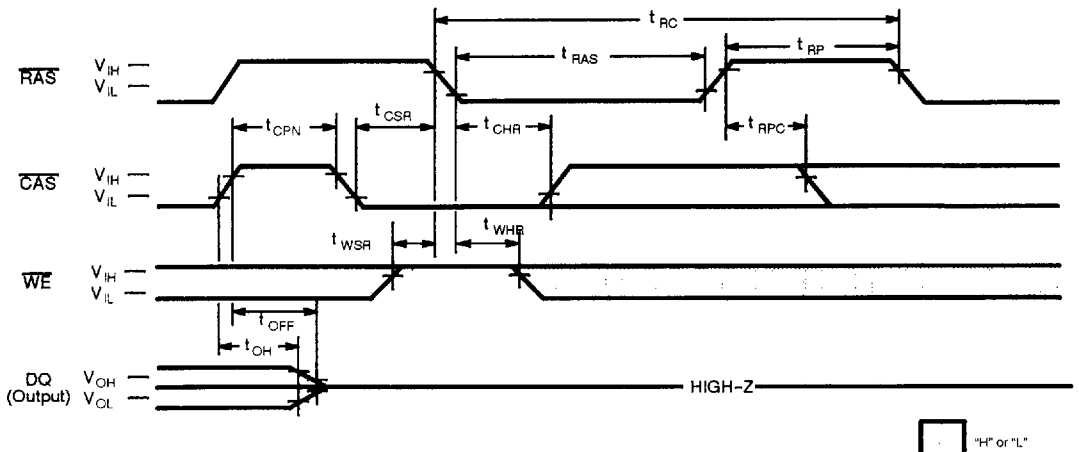

DESCRIPTION

$\overline{\text{CAS}}$ -before- $\overline{\text{RAS}}$ refresh is an on-chip refresh capability that eliminates the need for external refresh addresses. If $\overline{\text{CAS}}$ is held Low for the specified setup time (t_{CSR}) before $\overline{\text{RAS}}$ goes Low, the on-chip refresh control clock generators and refresh address counter are enabled. An internal refresh operation automatically occurs and the refresh address counter is internally incremented in preparation for the next $\overline{\text{CAS}}$ -before- $\overline{\text{RAS}}$ refresh operation.

Fig.15 - TEST MODE SET CYCLE (A0 to A11, $\overline{OE} = "H"$ or "L")

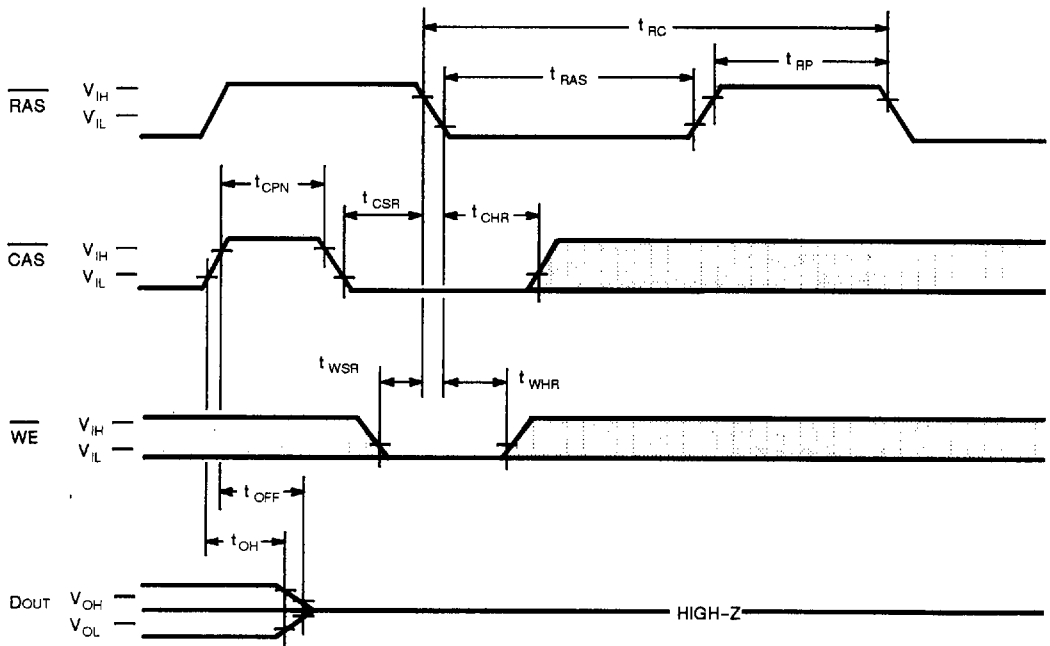

"H" or "L"

DESCRIPTION

Test Mode ;

The purpose of this test mode is to reduce device test time to one sixteenth of that required to test the device conventionally. The test mode function is entered by performing a \overline{WE} and \overline{CAS} -before- \overline{RAS} (WCBR) refresh for the entry cycle. In the test mode, read and write operations are executed in units of sixteenth bits which are selected by the address combination of CA0 and CA1. In the write mode, data is written into sixteenth cells simultaneously. But the data must be input from DQ1 only. In the read mode, the data of sixteenth cells at the selected addresses are read out from DQ and checked in the following manner.

When the sixteenth bits are all "L" or all "H", a "H" level is output.
 When the sixteenth bits show a combination of "L" and "H", a "L" level is output.

The test mode function is exited by performing a \overline{RAS} -only refresh or a \overline{CAS} -before- \overline{RAS} refresh for the exit cycle. In test mode operation, the following parameters are delayed approximately 10ns from the specified value in the data sheet.

t_{RC} , t_{RWC} , t_{RAC} , t_{CAC} , t_{AA} , t_{RAS} , t_{RSH} , t_{CAS} , t_{CSH} , t_{RAL} , t_{CAL} , t_{RWD} , t_{CWD} , t_{AWD}

Fig. 16 - CAS-BEFORE-RAS REFRESH COUNTER TEST CYCLE

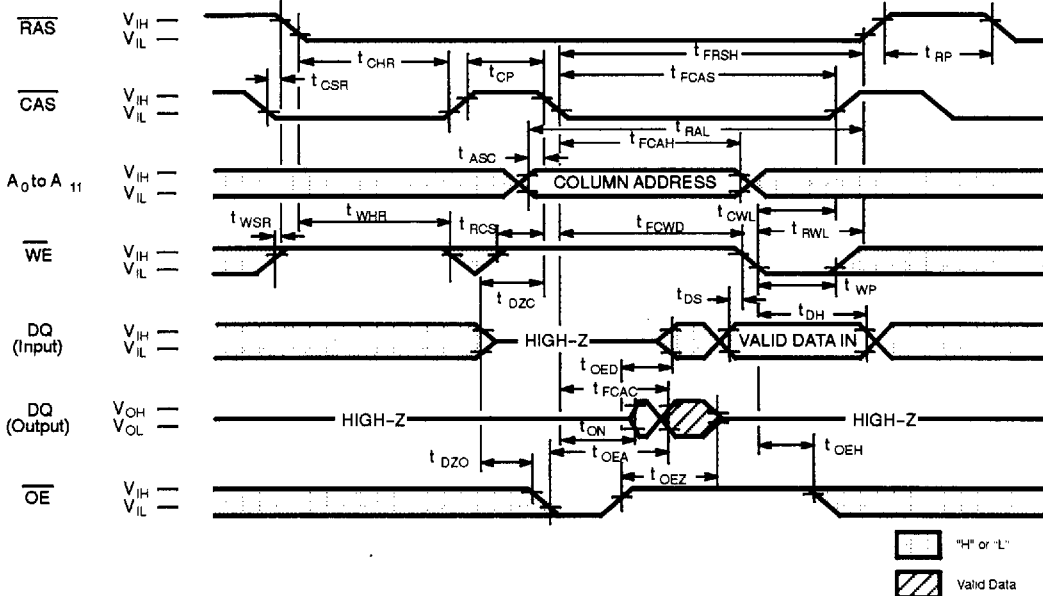

DESCRIPTION

A special timing sequence using the CAS-before-RAS refresh counter test cycle provides a convenient method to verify the functionality of CAS-before-RAS refresh circuitry. If, after a CAS-before-RAS refresh cycle CAS makes a transition from High to Low while RAS is held Low, read and write operations are enabled as shown above. Row and column addresses are defined as follows:

Row Address: Bits A0 through A11 are defined by the on-chip refresh counter.

Column Address: Bits A0 through A11 are defined by latching levels on A0-A11 at the second falling edge of CAS.

The CAS-before-RAS Counter Test procedure is as follows ;

- 1) Initialize the internal refresh address counter by using 8 RAS only refresh cycles.
- 2) Use the same column address throughout the test.
- 3) Write "0" to all 4096 row addresses at the same column address by using normal write cycles.
- 4) Read "0" written in procedure 3) and check; simultaneously write "1" to the same addresses by using CAS-before-RAS refresh counter test (read-modify-write cycles). Repeat this procedure 4096 times with addresses generated by the internal refresh address counter.
- 5) Read and check data written in procedure 4) by using normal read cycle for all 4096 memory locations.
- 6) Reverse test data and repeat procedures 3), 4), and 5).

(At recommended operating conditions unless otherwise noted.)

No.	Parameter	Symbol	MB8116400A-50		MB8116400A-60		MB8116400A-70		MB8116400A-80		Unit
			Min	Max	Min	Max	Min	Max	Min	Max	
90	Access Time from CAS	t_{FCAC}	—	45	—	50	—	55	—	60	ns
91	Column Address Hold Time	t_{FCAH}	35	—	35	—	35	—	35	—	ns
92	CAS to WE Delay Time	t_{FCWD}	63	—	70	—	77	—	85	—	ns
93	CAS Pulse width	t_{FCAS}	45	—	50	—	55	—	60	—	ns
94	RAS Hold Time	t_{FRSH}	45	—	50	—	55	—	60	—	ns

Note . Assumes that CAS-before-RAS refresh counter test cycle only.

MB8116400A-50
MB8116400A-60
MB8116400A-70
MB8116400A-80

PACKAGE DIMENSIONS

(Suffix : -PJ)

1

26-LEAD PLASTIC LEADED CHIP CARRIER (CASE No.: LCC-26P-M09)

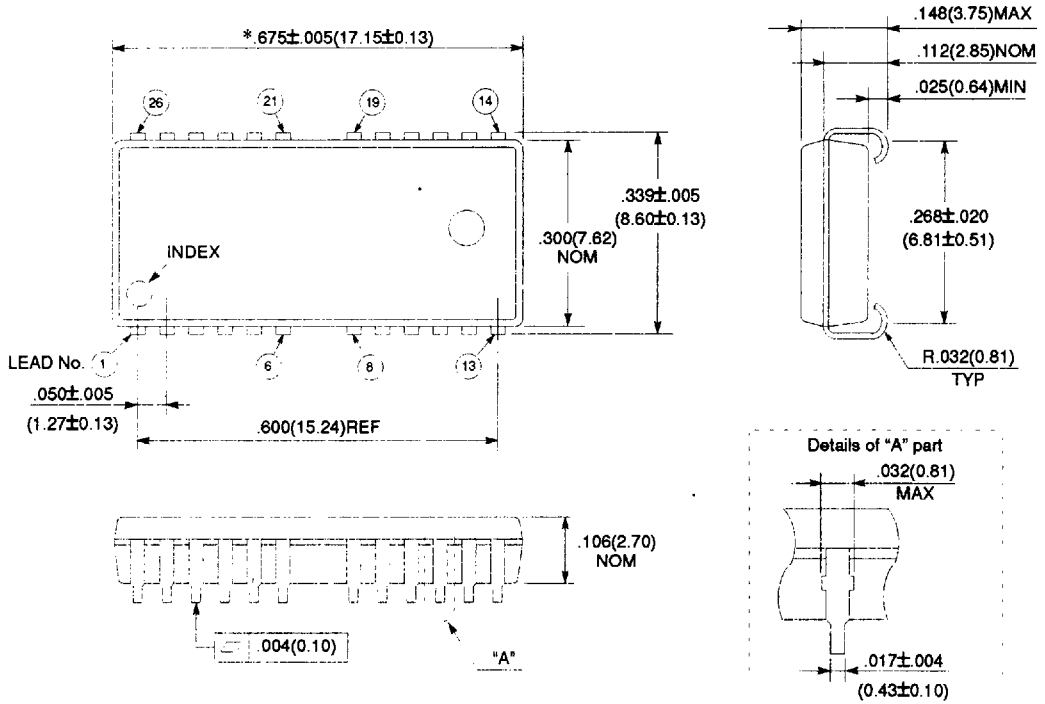

*: This dimension excludes resin protrusion. (Each side: $.006$ (0.15) MAX)
 ©1993 FUJITSU LIMITED C26059S-1C(W)

Dimensions in
 inches (millimeters)

PACKAGE DIMENSIONS (Continued)

(Suffix: - PFTN / PFTR)

26-LEAD PLASTIC FLAT PACKAGE (CASE No.: FPT-26P-M05)

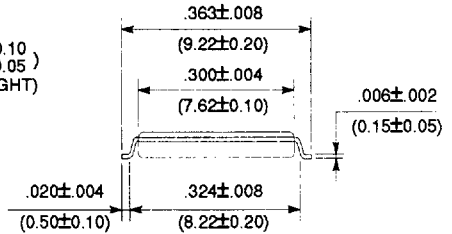
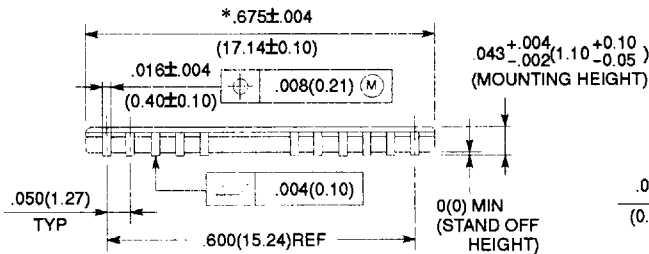
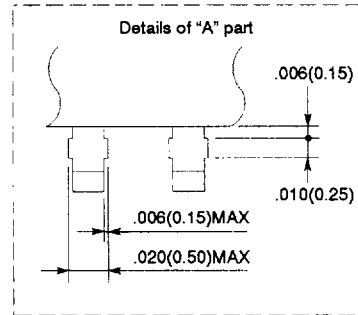
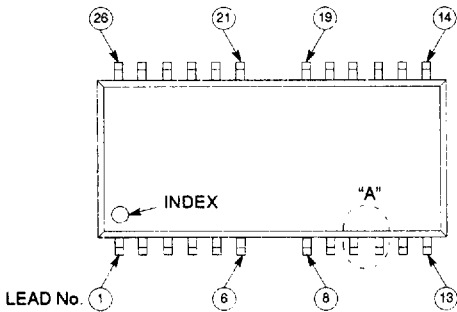

* Resin protrusion (Each side : .006(0.15) MAX)

0(0) MIN
 (STAND OFF
 HEIGHT)

©1993 FUJITSU LIMITED F26005S-1C

Dimensions in
 inches (millimeters)

1

MB8116400A-50
 MB8116400A-60
 MB8116400A-70
 MB8116400A-80

PACKAGE DIMENSIONS (Continued)

(Suffix: - PV)

1

24-LEAD PLASTIC SURFACE VERTICAL PACKAGE (CASE No.: SVP-24P-M01)

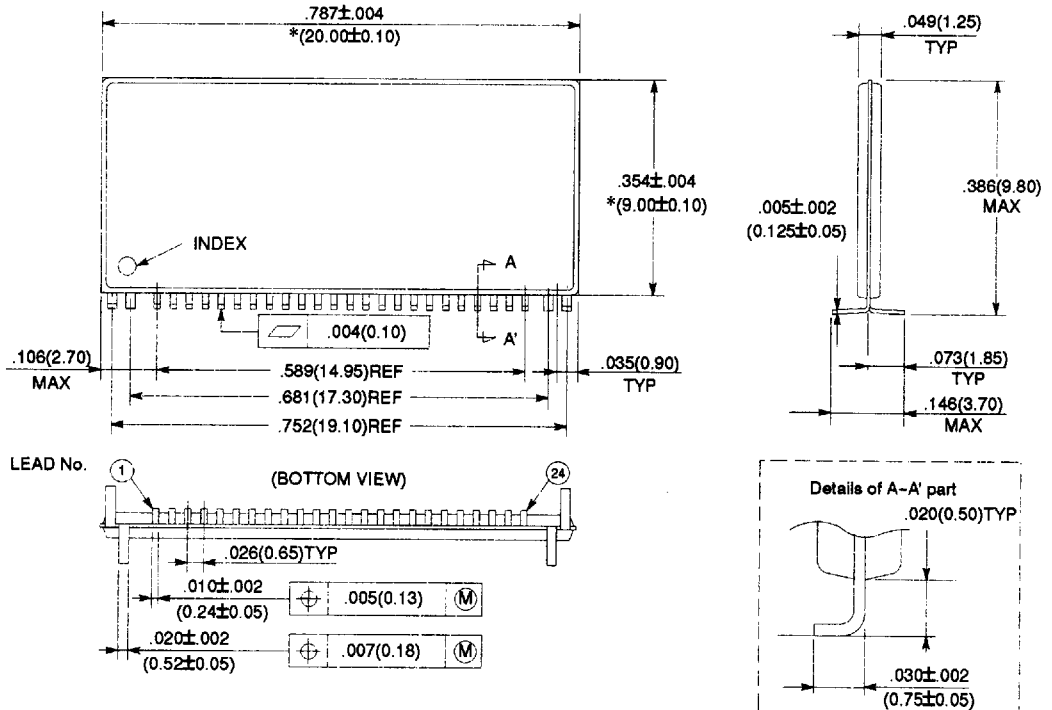

*: Resin protrusion [Each side: .004(0.10) Max]

©1993 FUJITSU LIMITED V24001S-1C-(W)

Dimensions in inches (millimeters)