

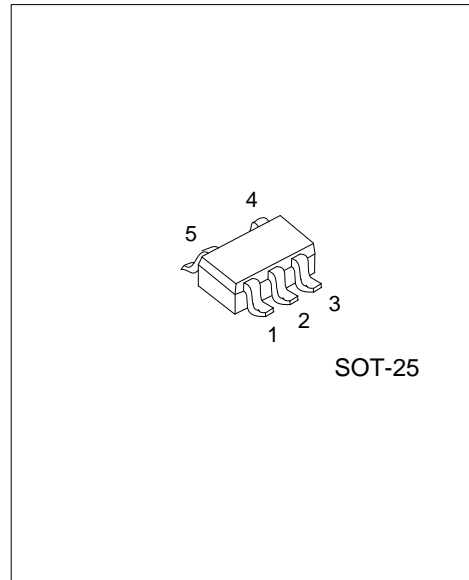

# LMV7235

## LINEAR INTEGRATED CIRCUIT

ULTRA LOW POWER LOW VOLTAGE RAIL-TO-RAIL INPUT COMPARATOR WITH OPEN-DRAIN OUTPUT



### DESCRIPTION

The UTC **LMV7235** is low power 75-ns comparator. It is ensured to operate over the full supply voltage range of 2.7V to 5.5V. The device achieves a 75-ns propagation delay while consuming only 65µA of supply current at 5V.

The UTC **LMV7235** has a greater than rail-to-rail common-mode voltage range. The input common mode voltage range extends 200mV below ground and 200mV above supply, allowing both ground and supply sensing.

The UTC **LMV7235** features an open drain output. By connecting an external resistor, the output of the comparator can be used as a level shifter.

### FEATURES

- \*  $V_S=5V, T_A=25^{\circ}C$  (Typical Values Unless Otherwise Specified)
- \* Propagation Delay: 75ns
- \* Low supply Current: 65µA
- \* Rail-to-Rail Input
- \* Open Drain Output
- \* Ideal for 2.7V and 5V, Single-Supply Applications

### ORDERING INFORMATION

Ordering Number		Package	Packing
Lead Free	Halogen Free		
LMV7235L-AF5-R	LMV7235G-AF5-R	SOT-25	Tape Reel

<p>LMV7235G-AF5-R</p> <ul style="list-style-type: none"> <li>(1)Packing Type</li> <li>(2)Package Type</li> <li>(3)Green Package</li> </ul>	<ul style="list-style-type: none"> <li>(1) R: Tape Reel</li> <li>(2) AF5: SOT-25</li> <li>(3) G: Halogen Free and Lead Free, L: Lead Free</li> </ul>
--	--

### MARKING

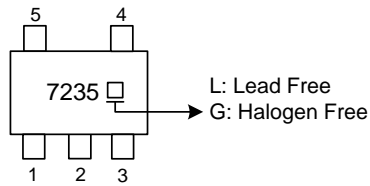

### PIN CONFIGURATION

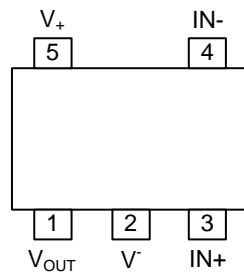

### PIN DESCRIPTION

PIN NO.	PIN NAME	DESCRIPTION
1	V <sub>OUT</sub>	Output
2	V <sup>-</sup>	Negative Supply
3	IN <sup>+</sup>	Non-inverting Input
4	IN <sup>-</sup>	Inverting Input
5	V <sup>+</sup>	Positive Supply

### BLOCK DIAGRAM

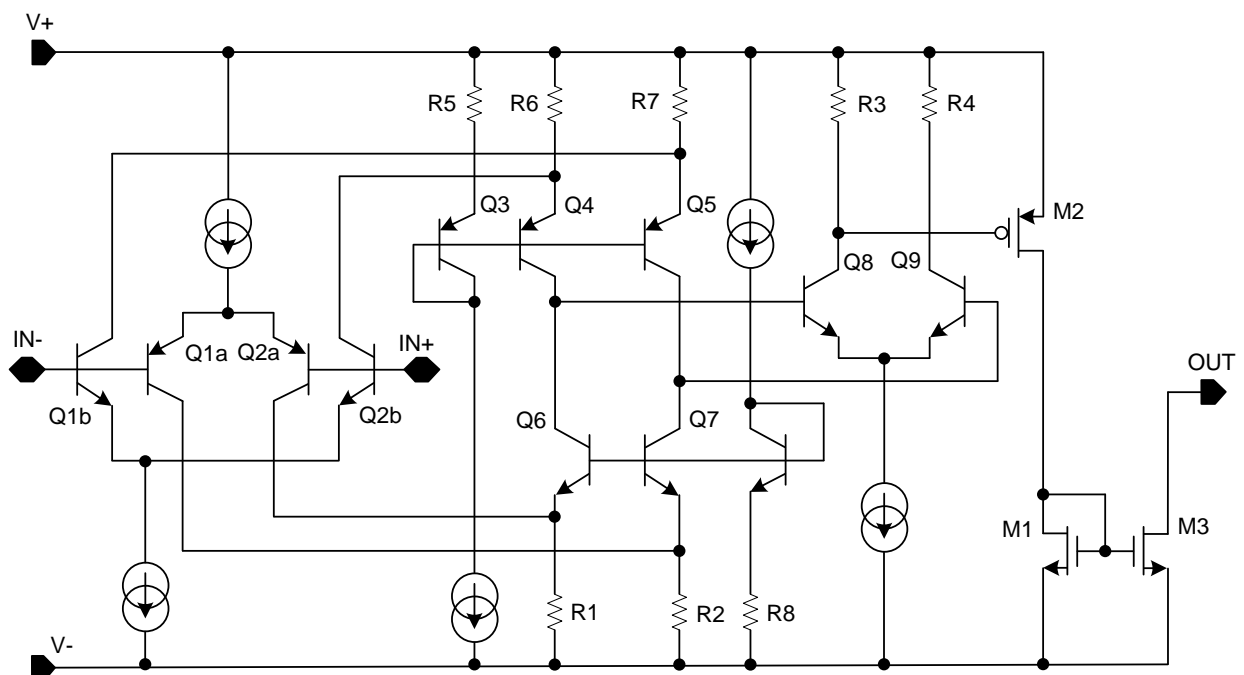

■ ABSOLUTE MAXIMUM RATING (T<sub>A</sub> =25°C, unless otherwise specified)

PARAMETER	SYMBOL	RATINGS	UNIT
Supply Voltage (V <sup>+</sup> - V <sup>-</sup> )	V <sub>S</sub>	6	V
Differential Input Voltage		± Supply Voltage	V
Output Short Circuit Duration		See (Note 2)	
<b>SOLDERING INFORMATION</b>			
Voltage at Input/Output Pins		(V <sup>+</sup> ) +0.3, (V <sup>-</sup> ) - 0.3	V
Current at Input Pin (Note 2)		±10	mA
Junction Temperature	T <sub>J</sub>	+150	°C
Storage Temperature	T <sub>STG</sub>	-65 ~ +150	°C

Notes: 1. Absolute maximum ratings are those values beyond which the device could be permanently damaged. Absolute maximum ratings are stress ratings only and functional device operation is not implied.

2. Applies to both single-supply and split-supply operation. Continuous short circuit operation at elevated ambient temperature can result in exceeding the maximum allowed junction temperature of 150°C. Output currents in excess of 30mA over long term may adversely affect reliability.

3. Limiting input pin current is only necessary for input voltages that exceed absolute maximum input voltage ratings.

■ RECOMMENDED OPWRAING CONDITIONS

PARAMETER	SYMBOL	RATINGS	UNIT
Supply Voltage (V <sup>+</sup> - V <sup>-</sup> )	V <sub>S</sub>	2.7 ~ 5.5	V
Temperature Range	T <sub>A</sub>	-40 ~ +85	°C

■ 2.7V ELECTRICAL CHARACTERISTICS

(Unless otherwise specified, all limits ensured for T<sub>A</sub>=25°C, V<sub>CM</sub>=V<sup>+</sup>/2, V<sup>+</sup> = 2.7V, V<sup>-</sup> = 0V.)

PARAMETER	SYMBOL	TEST CONDITIONS	MIN	TYP	MAX	UNIT
Input Offset Voltage	V <sub>OS</sub>		-6	±0.8	+6	mV
Input Bias Current	I <sub>B</sub>			30	400	nA
Input Offset Current	I <sub>OS</sub>			5	200	nA
Common-Mode Rejection Ratio	CMRR	0V < V <sub>CM</sub> < 2.7V (Note 1)	52	62		dB
Power Supply Rejection Ratio	PSRR	V <sup>+</sup> = 2.7V~5V	65	85		dB
Input Common-Mode Voltage Range	V <sub>CM</sub>	CMRR > 50dB	V <sup>-</sup> - 0.1	-0.2~ 2.9	V <sup>+</sup> +0.1	V
Output Swing Low	V <sub>O</sub>	I <sub>L</sub> =-4mA, V <sub>ID</sub> =-500mV		230	350	mV
		I <sub>L</sub> =-0.4mA, V <sub>ID</sub> =-500mV		15		mV
Output Short Circuit Current	I <sub>SC</sub>	Sinking, V <sub>O</sub> =2.7V, R <sub>L</sub> =10kΩ		15		mA
Supply Current	I <sub>S</sub>	No load		52	85	μA
Propagation Delay	t <sub>PD</sub>	Overdrive =20mV C <sub>LOAD</sub> =15pF (Note 2)		96		ns
		Overdrive =50mV C <sub>LOAD</sub> =15pF (Note 2)		87		ns
		Overdrive =100mV C <sub>LOAD</sub> =15pF (Note 2)		85		ns
Output Rise Time	t <sub>r</sub>	10%~90% (Note 2)		112		ns
Output Fall Time	t <sub>f</sub>	90%~10%		2.5		ns
Output Leakage Current	I <sub>LEAKAGE</sub>			3		nA

Notes: 1. CMRR is not linear over the common mode range. Limits are guaranteed over the worst case from 0 to V<sub>CC</sub>/2 or V<sub>CC</sub>/2 to V<sub>CC</sub>.

2. A 10kΩ pullup resistor was used when measuring the UTC **LMV7235**. The rise time of the UTC **LMV7235** is a function of the R-C time constant.

### ■ 5V ELECTRICAL CHARACTERISTICS

(Unless otherwise specified, all limits ensured for  $T_A=25^\circ\text{C}$ ,  $V_{CM}=V^+/2$ ,  $V^+=5\text{V}$ ,  $V^-=0\text{V}$ .)

PARAMETER	SYMBOL	TEST CONDITIONS	MIN	TYP	MAX	UNIT
Input Offset Voltage	$V_{OS}$		-6	$\pm 1$	+6	mV
Input Bias Current	$I_B$			30	400	nA
Input Offset Current	$I_{OS}$			5	200	nA
Common-Mode Rejection Ratio	CMRR	$0\text{V} < V_{CM} < 5\text{V}$	52	67		dB
Power Supply Rejection Ratio	PSRR	$V^+ = 2.7\text{V} \sim 5\text{V}$	65	85		dB
Input Common-Mode Voltage Range	$V_{CM}$	CMRR > 50dB	$V^- - 0.1$	-0.2~ 5.2	$V^+ + 0.1$	V
Output Swing Low	$V_O$	$I_L = -4\text{mA}$ , $V_{ID} = -500\text{mV}$		230	350	mV
		$I_L = -0.4\text{mA}$ , $V_{ID} = -500\text{mV}$		10		mV
Output Short Circuit Current	$I_{SC}$	Sinking, $V_O = 5\text{V}$ , $R_L = 10\text{k}$	30	50		mA
Supply Current	$I_S$	No load		45	95	$\mu\text{A}$
Propagation Delay	$t_{PD}$	Overdrive = 20mV $C_{LOAD} = 15\text{pF}$ (Note 1)		89		ns
		Overdrive = 50mV $C_{LOAD} = 15\text{pF}$ (Note 1)		82		ns
		Overdrive = 100mV $C_{LOAD} = 15\text{pF}$ (Note 1)		75		ns
Output Rise Time	$t_r$	10%~90%		100		ns
Output Fall Time	$t_f$	90%~10%		1.7		ns
Output Leakage Current	$I_{LEAKAGE}$			3		nA

Note: A 10k $\Omega$  pullup resistor was used when measuring the UTC **LMV7235**. The rise time of the UTC **LMV7235** is a function of the R-C time constant.

UTC assumes no responsibility for equipment failures that result from using products at values that exceed, even momentarily, rated values (such as maximum ratings, operating condition ranges, or other parameters) listed in products specifications of any and all UTC products described or contained herein. UTC products are not designed for use in life support appliances, devices or systems where malfunction of these products can be reasonably expected to result in personal injury. Reproduction in whole or in part is prohibited without the prior written consent of the copyright owner. UTC reserves the right to make changes to information published in this document, including without limitation specifications and product descriptions, at any time and without notice. This document supersedes and replaces all information supplied prior to the publication hereof.