

## Radio On A Chip 2400 MHz Frequency Agile With SPI Bus Interface

### Features

- 2.4 GHz Operating Frequency
- High Level of Integration Minimizes System Cost
- Data Rates over 128.8 Kbits/Sec
- Direct Connection To Microprocessor
- Integrated Antenna Switch
- Adjustable detection bandwidths, data rates
- Adjustable gain, detection level/ hysteresis
- Low and high beta FSK detection modes
- Integrated Manchester coding/decoding
- Programmable Power, Frequency And Tx/Rx/Standby Modes
- Operates From Single 2.5V Power Supply
- Surface Mount Leadless Plastic Packaging

### Description

The Honeywell HRF-ROC094XC is a half-duplex transceiver for use in wireless communication and data applications. Direct microprocessor connection for control and data transfer, eliminate the need for additional ICs, while integrated data encode/decode reduces the instruction set requirements on the microprocessor. The HRF-ROC094XC is ideally suited for use in battery powered wireless applications in conjunction with microprocessors for voice and data communication. Adjustable data rates, filter bandwidths and detection levels allow the IC to be used in a wide variety of high sensitivity / high EMI environments.

### Product Photo

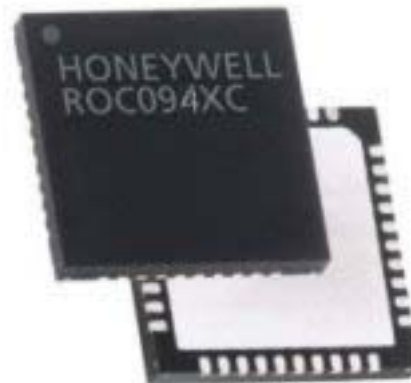

### Functional Schematic

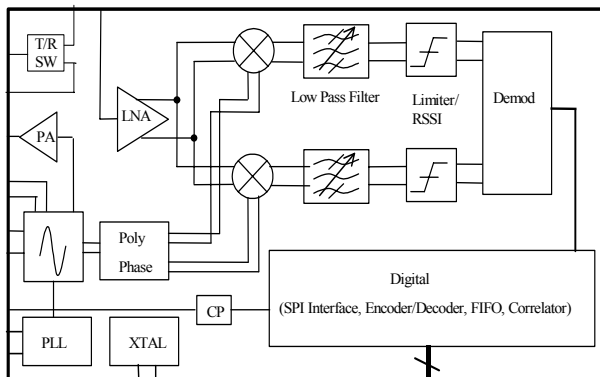

Web Site: [www.mysoiservices.com](http://www.mysoiservices.com)  
Email: [mysoiservices@honeywell.com](mailto:mysoiservices@honeywell.com)

2003 09425XC Published June 2003 Page 1

Honeywell  
Solid State Electronics Center  
12001 State Highway 55  
Plymouth, Minnesota 55441-4799  
1-800-323-8295

# HRF-ROC094XC



Advance Information

## RF Electrical Specifications @ + 25°C

Parameter	Test Condition	Frequency	Minimum	Typical	Maximum	Units
Rx Sensitivity		2400-2500 MHz		-95		dBm
1db Compression	Vdd = 2.5V	2400-2500 MHz		+5		dBm
Tx Output Power	Vdd = 2.5V	2400-2500 MHz		+3		dBm
Tx Power Control				18		dB
Data Rate, Tx / Rx	Continuous PacketizedData			128		Kbps
Channel Rejection	Adjacent Channels	Fc + 1MHz		50		dB
Max Detection BW*	IQ Baseband Filter Passband			250		KHz
Control/Data I/O	Serial Peripheral Interface (SPI). Direct Connection To Micro controller/Microprocessor			10		MHz

\* Bandwidth reduction possible using off chip elements

## DC Electrical Specifications @ + 25°C

Parameter	Minimum	Typical	Maximum	Units
V <sub>DD</sub> Power Supply Voltage	2.4	2.5	2.6	V
Power Supply Current During Tx, Output Power Dependant (2450 MHz)	16	26		mA
Power Supply Current (I <sub>DD</sub> ) During Rx (2450MHz)		35		mA
Sleep Mode Current Consumption		<1		uA
CMOS Logic Level (0)	0		0.7	V
CMOS Logic Level (1)	1.7		V <sub>DD</sub>	V

## Absolute Maximum Ratings<sup>1</sup>

Parameter	Absolute Maximum	Units
Maximum Input Power	-	-
V <sub>DD</sub>	+ 2.8	V
ESD Voltage (Human Body Model)	200	V
Operating Temperature	- 40 to + 85	Degrees C
Storage Temperature	- 40 to + 150	Degrees C

(Note 1) Operation Of The HRF-ROC094XC Beyond Any Of These Parameters May Cause Permanent Damage.

**ESD Protection:** The HRF-ROC094XC Contains reduced ESD Protection Circuitry for sensitive RF I/O. Precautions Should Be Taken During Handling/Assembly Until Protected By External Circuitry or Housings

## Typical Application

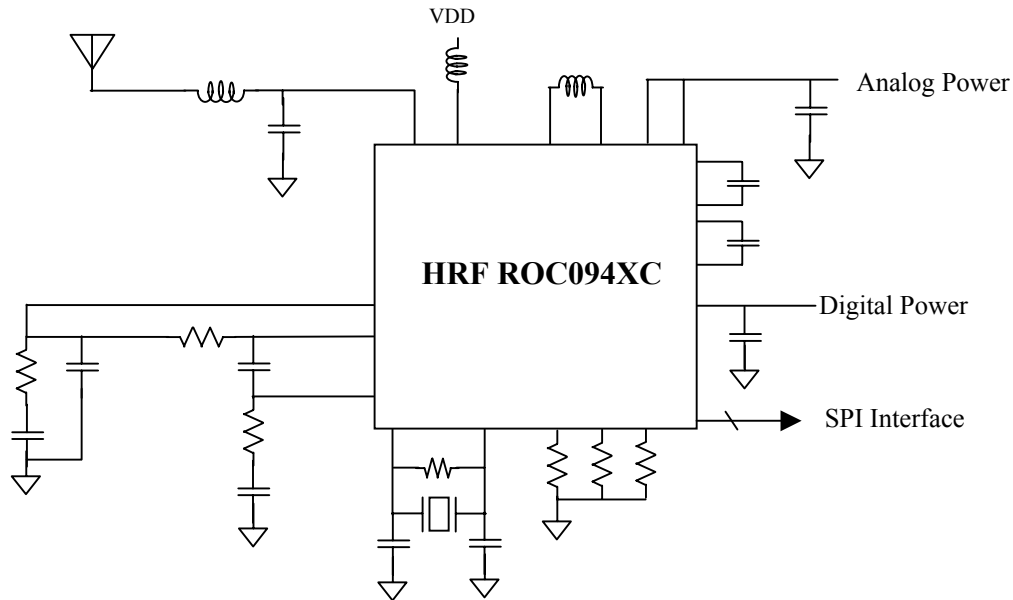

## Package Outline

7mm x 7mm  
 48 pin Leadless  
 Plastic Chip Carrier

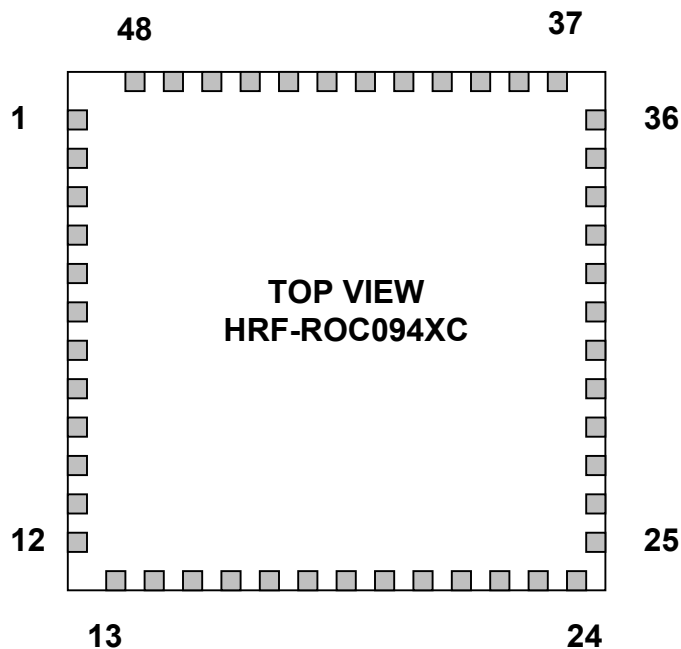

Low inductance RF/DC ground connection required below part as bottom ground pad is used for all device grounding. Additionally, this connection provides a direct connection to the die for enhanced thermal dissipation. **Package shown not to scale.**

Web Site: [www.mysoiservices.com](http://www.mysoiservices.com)  
 Email: [mysoiservices@honeywell.com](mailto:mysoiservices@honeywell.com)

# HRF-ROC094XC



Advance Information

## Pin Configuration

### HRF-ROC094XC 48 Pin LPCC™ (7 mm X 7 mm) Package Pin List

\* RF/Digital ground is provided through backside slug pad.

Pin	Name	Function	Pin	Name	Function
1	SWITCH TX	Optional connection – PA AC OUT to SWITCH ANTENNA	25	SPI CLK IN	SPI Clock
2	PA AC OUT	AC-coupled PA output – 10 pf series cap	26	SPI SSN IN	SPI Slave Select
3	VP PA	Positive supply for PA	27	DIG DATA IN	Digital Section Rx Text Input, Ext. digital data
4	PA DC OUT	PA Direct Connection for output bias	28	SPI DATA IN	SPI Serial Data input
5	VCO TANK2	VCO external tank connection	29	RESET N	Digital Section Reset
6	VCO TANK1	VCO external tank connection	30	MIXER REF	Mixer Ref Voltage Filter
7	VP VCO	Positive supply for VCO	31	SCHM TRIG LEV	Detection level monitor/filtering
8	VMOD LG	VCO varactor input, high deviation	32	PRE TRIG DATA	RX Analog Data, pre-detection
9	VMOD SM	VCO varactor input, low deviation	33	V CM REF	Common mode voltage filtering
10	TX MOD DATA	Data charge pump output	34	VP BB	Positive supply for Baseband Filter
11	VP PLL	Positive supply for PLL	35	Q FILT BW N	BB Filter BW Control
12	REXT PLL	PLL bias resistor	36	Q FILT BW P	BB Filter BW Control
13	PD OUT	Phase Detector charge pump output	37	I FILT BW N	BB Filter BW Control
14	CRYSTAL 1	Reference crystal	38	I FILT BW P	BB Filter BW Control
15	CRYSTAL 2	Reference crystal	39	Q MIX ADJ	Dynamic Range Adjust
16	RTEST OUT	PLL R-counter out	40	I MIX ADJ	Dynamic Range Adjust
17	PTEST OUT	PLL N-counter output	41	VP MIX	Positive supply for Mixer
18	SQUELCH 1	Bit 1, 4-level window Select	42	VP LNA	Positive supply for LNA
19	SQUELCH 2	Bit 1, 4-level window Select	43	RF GAIN	LNA Gain Control: open – low, ground – high
20	VP DIG	Positive supply for DIG	44	VP LNA	Positive supply for LNA
21	RX OUT	Demodulated Rx data	45	LNA INPUT	LNA input
22	TX DATA V	Logic level Tx data	46	LNA BIAS ADJ	DC Bias Resistor
23	SPI INT OUT	SPI Interrupt output	47	SWITCH RX	Optional connection – LNA INPUT to SWITCH ANTENNA
24	SPI DATA OUT	SPI Serial Data output	48	SW ANTENNA	Switch connection to Antenna

# HRF-ROC094XC



Advance Information

## Customer Demonstration Board

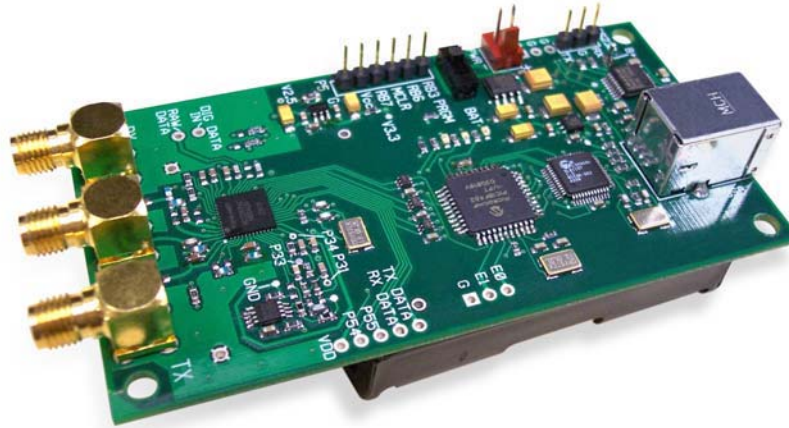

The Customer Demonstration Board provides the ROC094XC radio with a PIC microcontroller that interfaces to a PC through a USB connection. Using the software provided and a PC, the user can send files and perform range tests. For a more complete understanding of the operation of the radio, the user can also control the operating frequency, power levels and all internal registers for early product development/prototyping. The board operates from a USB power source, three "AA" batteries or an external power supply. Single antenna operation is attained through the internal RF switch. Separate Tx/Rx/ ports are also available.

A kit is available, HRF-ROC094XC-K, which includes two boards, antennas, USB cable, documentation and control software.

## Ordering Information

Ordering Number	Product
HRF-ROC094XC -T	Delivered On Tape And Reel <sup>2</sup>
HRF-ROC094XC -K	Engineering Evaluation Kit

Note 2: Contact Honeywell for details

Honeywell reserves the right to make changes to improve reliability, function or design. Honeywell does not assume any liability arising out of the application or use of any product or circuit described herein; neither does it convey any license under its patent rights nor the rights of others.

Web Site: [www.mysoiservices.com](http://www.mysoiservices.com)  
Email: [mysoiservices@honeywell.com](mailto:mysoiservices@honeywell.com)

2003 09425XC Published June 2003 Page 5

Honeywell  
Solid State Electronics Center  
12001 State Highway 55  
Plymouth, Minnesota 55441-4799  
1-800-323-8295