

Description

The SL5015/P is an noise reduction IC for cordless phone. It is a compandor IC that consist of a compressor and an expander. Compandor reduces transmission noise by compressing and transmitting out going signals and expanding received signals.

The ICs are designed for minimum requirement of external components and for low voltage operation. Small size is an advantage when used in equipment in which space is a premium. For DATA, input and output terminals are provided for convenience. Two styles of packaging, DIP and SOP, are available to meet different requirements.

Features

- Low voltage operation $V_{opr.} = 2.4 \sim 7.0V$
- Low current consumption $I_{CC} = 4mA (V_{CC}=3V)$
- Microphone amplifier used in compressor
- Has data input output terminals
- Has a buffer amplifier for filter
- Mute can be set up independently
- Through Functions
- Built in limiter (for compressor)

Ordering Information

Type NO.	Marking	Package Code
SL5015	SL5015	SOP20
SL5015P	SL5015	DIP20

Outline Dimensions

unit : mm

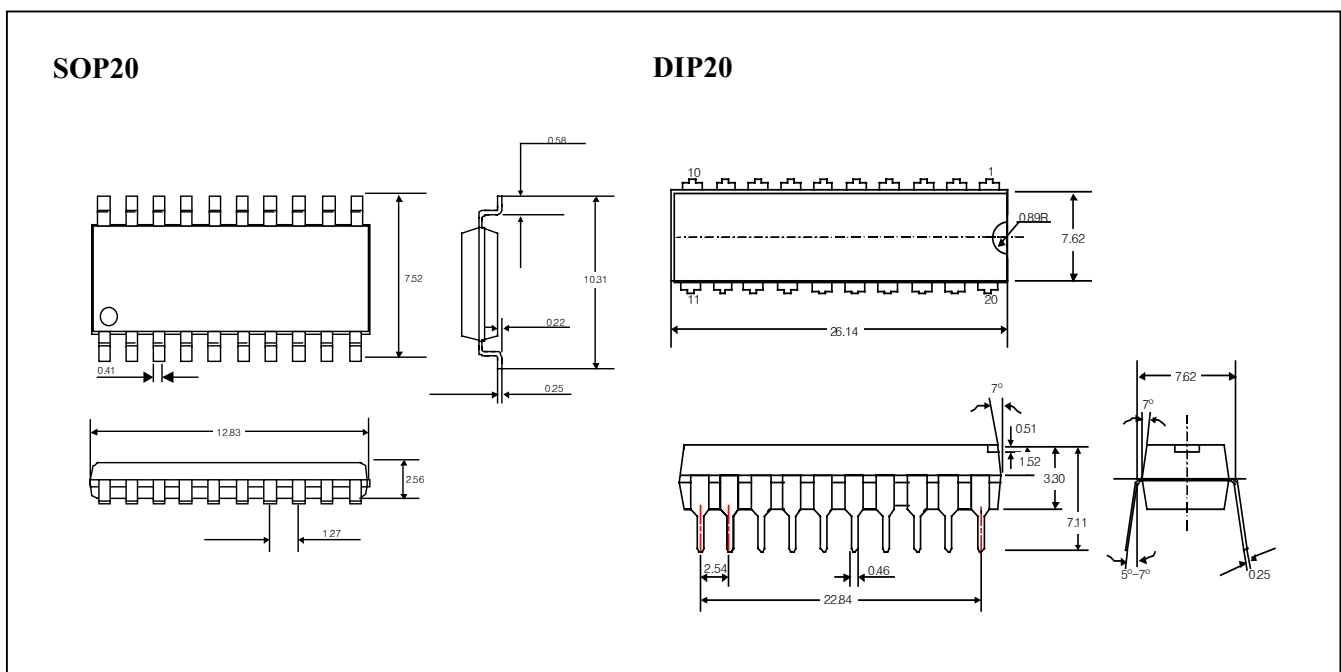

Absolute Maximum Ratings

(Ta = 25°C)

Characteristics	Symbol	Rating	Unit
Maximum Supply Voltage	V _{CC}	10	V
Power Dissipations	P _D	1000(D) note 1	mW
		410(S) note 2	
Operating Temperature Range	T _{opr}	-20 ~ 70	°C
Storage Temperature Range	T _{stg}	-55 ~ 150	°C

* note 1. Above Ta=+25 °C , derate at 8mW/°C

2. Above Ta=+25 °C, derate at 3.3mW/°C

Block Diagram and Test Circuit

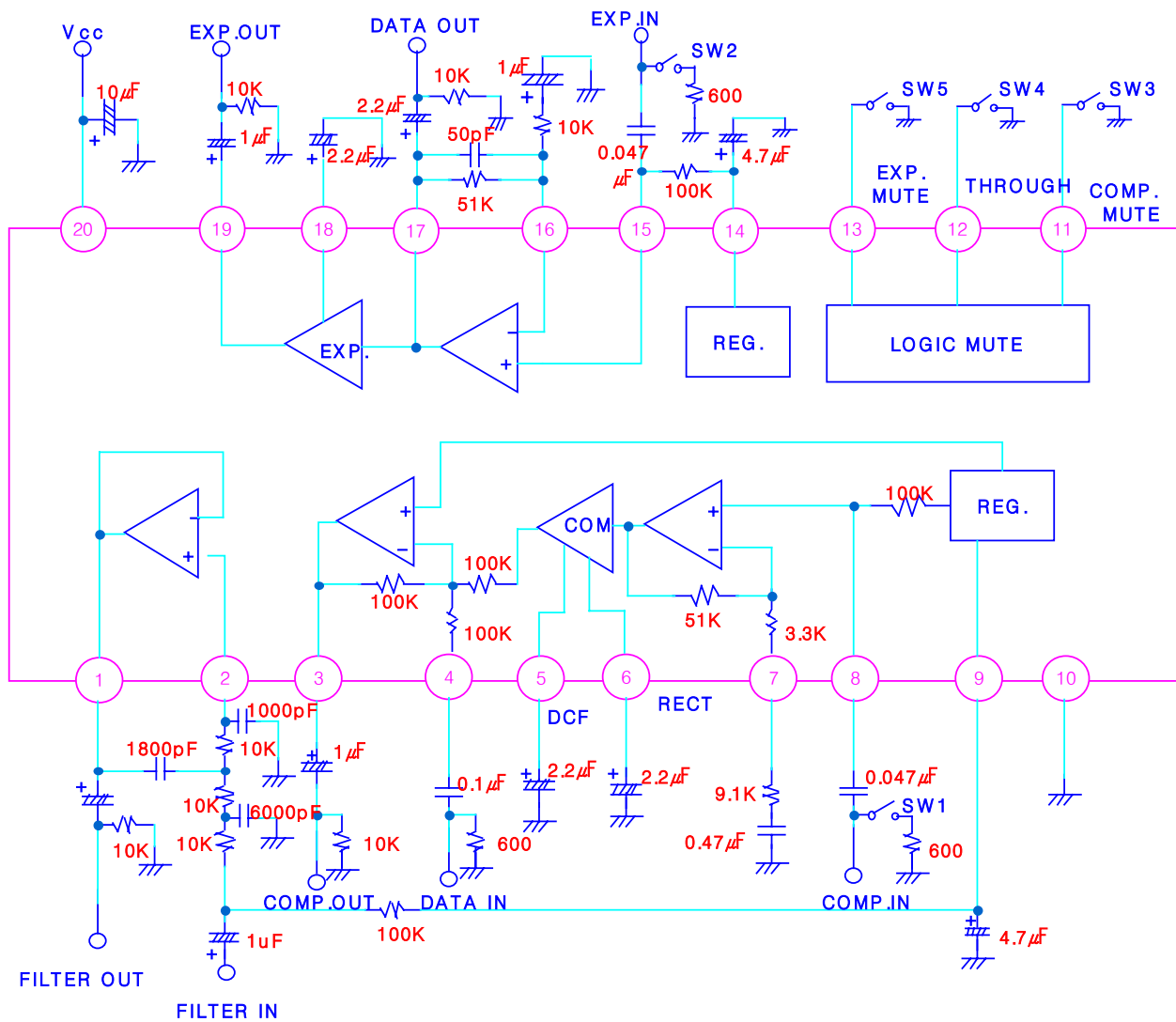

Switch Position

Switch terminal	High (Open or Vcc)	Low(GND)
PIN 11(SW3)	Comp Mute OFF	Comp Mute ON
PIN 12(SW4)	Compandor	Through
PIN 13(SW5)	Exp Mute OFF	Exp Mute ON
PIN 8 (SW1)	Signal Input → OFF	
PIN 15 (SW2)	Signal Input → OFF	

Electrical Characteristics

(Unless otherwise specified, Ta=25 °C, Vcc=3V, f=1kHz, RL = 10 kΩ)

Characteristics	Symbol	Test Conditions	Min.	Typ.	Max.	Unit
Squelch Current	I _{CCQ}	No Signal	-	4.0	6.5	mA
Reference Voltage	V _{ref}	-	1.4	1.5	1.55	V
Compressor						
Input Resistance	R _{IN}	-	90	120	-	kΩ
Standard Input Level	V _{IN}	V _{OUT} =300mV _{rms} = 0dB	8.0	12.5	17.0	mV _{rms}
Gain error(1)	ΔG _V (1)	V _{IN} = -20dB	-0.5	0	+0.5	dB
Gain error(2)	ΔG _V (2)	V _{IN} = -40dB	-0.1	0	+1.0	dB
Through ON/OFF Diff.	ΔG _V	V _{IN} =0dB, 12 pin GND	-1.5	0	+1.5	dB
Distortion	THD	V _{IN} = 620 Ω	-	0.5	1.0	%
Noise output	V _{NO}	Rg= 620 Ω	-	3.0	5.5	mV _{rms}
Muting attenuation	M _{ATT}	V _{IN} = 0dB, 11 Pin GND	60	80	-	dB
Limiting voltage	V _{LI}	-	1.15	1.35	1.50	V _{p-p}
Expander						
Standard Input Level	V _{OUT}	V _{IN} = 30mV _{rms} = 0dB	110	130	160	mV _{rms}
Gain error(1)	ΔG _V (1)	V _{IN} = -10dB	-0.5	0	+0.5	dB
Gain error(2)	ΔG _V (2)	V _{IN} = -20dB	-1.0	0	+1.0	dB
Gain error(3)	ΔG _V (3)	V _{IN} = -30dB	-1.5	0	+1.5	dB
Through ON/OFF Diff.	ΔG _V	V _{IN} = 0dB, 12 Pin GND	-2.5	-1.0	+0.5	dB
Distortion	THD	V _{IN} = 0dB	-	0.5	1.5	%
Noise output	V _{NO}	Rg= 620 Ω	-	10	30	μ V _{rms}
Muting attenuation	M _{ATT}	V _{IN} = 0dB, 13 pin	60	80	-	dB
Max. output voltage	V _{OUT(max)}	THD 10% level	700	800	-	mV _{rms}

Electrical Characteristics(continued)

(Unless otherwise specified, Ta=25 °C, Vcc=3V, f=1kHz, RL = 10 kΩ)

Characteristics	Symbol	Test Conditions	Min.	Typ.	Max.	Unit
Buffer Amp(LPF)						
Voltage Gain	G_V	$V_{IN} = 300mV_{rms}$	-0.5	0	0.5	dB
Freq Charact(1)	Δf_1	$V_{IN}=300mV_{rms}, f=3kHz$	-4.5	-3	0	dB
Freq Charact(2)	Δf_2	$V_{IN}=300mV_{rms}, f=30kHz$	-75	-60	-55	dB
Distortion	THD	$V_{IN} = 300mV_{rms}$	-	0.02	0.1	%

(PIN VOLTAGE AT VCC=3V AND NO INPUT SIGNAL)

Pin. No.	NAME	TYPE. VAL	Unit	Pin. No.	NAME	TYPE. VOL	Unit
1	FILTER OUT	1.5	V	11	COMP MUTE	1.3	V
2	FILTER IN	1.5	V	12	THROUGH	1.3	V
3	COMP OUT	1.5	V	13	EXP MUTE	1.3	V
4	DATA IN	1.5	V	14	EXP REF	1.5	V
5	C-DCF	1.5	V	15	EXP IN	1.5	V
6	COMP RECT	0.6	V	16	EXP NF	1.5	V
7	COMP NF	1.5	V	17	DATA OUT	1.5	V
8	COMP IN	1.5	V	18	EXP RECT	0.6	V
9	COMP REF	1.5	V	19	EXP OUT	1.5	V
10	GND	GND	V	20	VCC	VCC	V

Typical Performance Characteristics

- Input Voltage VS Output Voltage

