

SN54HC153, SN74HC153 DUAL 4-LINE TO 1-LINE DATA SELECTORS/MULTIPLEXERS

D2684, DECEMBER 1982 - REVISED SEPTEMBER 1987

- Permits Multiplexing from N Lines to 1 Line
- Performs Parallel-to-Serial Conversion
- Strobe (Enable) Line Provided for Cascading (N lines to n lines)
- Package Options Include Plastic "Small Outline" Packages, Ceramic Chip Carriers, and Standard Plastic and Ceramic 300-mil DIPs
- Dependable Texas Instruments Quality and Reliability

description

Each of these data selectors/multiplexers contains inverters and drivers to supply full binary decoding data selection to the AND-OR gates. Separate strobe inputs (\bar{G}) are provided for each of the two four-line sections.

The SN54HC153 is characterized for operation over the full military temperature range of -55°C to 125°C . The SN74HC153 is characterized for operation from -40°C to 85°C .

FUNCTION TABLE

SELECT INPUTS		DATA INPUTS				STROBE	OUTPUT
B	A	C0	C1	C2	C3	\bar{G}	Y
X	X	X	X	X	X	H	L
L	L	L	X	X	X	L	L
L	L	H	X	X	X	L	H
L	H	X	L	X	X	L	L
L	H	X	H	X	X	L	H
H	L	X	X	L	X	L	L
H	L	X	X	H	X	L	H
H	H	X	X	X	L	L	L
H	H	X	X	X	H	L	H

Select inputs A and B are common to both sections.
H = high level, L = low level, X = irrelevant

SN54HC153 . . . J PACKAGE
SN74HC153 . . . D/DW† OR N PACKAGE
(TOP VIEW)

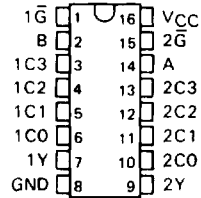

SN54HC153 . . . FK PACKAGE
(TOP VIEW)

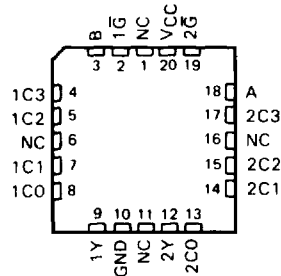

NC—No internal connection

†Contact the factory for D or DW availability.

logic symbol‡

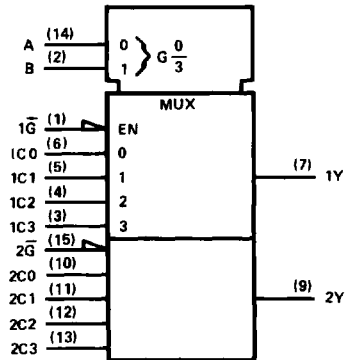

‡ This symbol is in accordance with ANSI/IEEE Std 91-1984 and IEC Publication 617-12.

Pin numbers shown are for D/DW, J, and N packages.

2
HCMOS Devices

PRODUCTION DATA documents contain information current as of publication date. Products conform to specifications per the terms of Texas Instruments standard warranty. Production processing does not necessarily include testing of all parameters.



POST OFFICE BOX 655012 • DALLAS, TEXAS 75265

Copyright © 1982, Texas Instruments Incorporated

2-205

SN54HC153, SN74HC153
DUAL 4-LINE TO 1-LINE DATA SELECTORS/MULTIPLEXERS

logic diagram (positive logic)

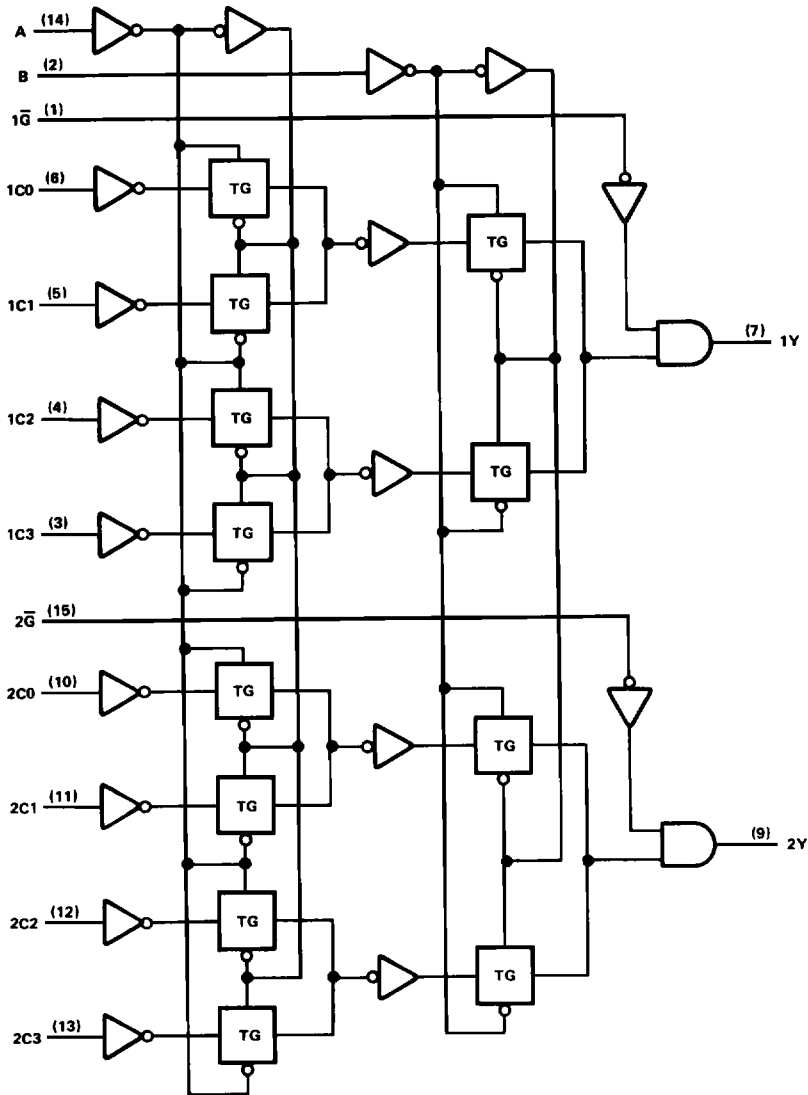

Pin numbers shown are for D/DW†, J, and N packages.

†Contact the factory for D or DW availability.

SN54HC153, SN74HC153 DUAL 4-LINE TO 1-LINE DATA SELECTORS/MULTIPLEXERS

2
HCMOS Devices

absolute maximum ratings over operating free-air temperature range[†]

Supply voltage, V_{CC}	-0.5 V to 7 V
Input clamp current, I_{IK} ($V_I < 0$ or $V_I > V_{CC}$)	± 20 mA
Output clamp current, I_{OK} ($V_O < 0$ or $V_O > V_{CC}$)	± 20 mA
Continuous output current, I_O ($V_O = 0$ to V_{CC})	± 35 mA
Continuous current through V_{CC} or GND pins	± 70 mA
Lead temperature 1,6 mm (1/16 in) from case for 60 s: FK or J package	300°C
Lead temperature 1,6 mm (1/16 in) from case for 10 s: D/DW or N package	260°C
Storage temperature range	-65°C to 150°C

[†] Stresses beyond those listed under "absolute maximum ratings" may cause permanent damage to the device. These are stress ratings only, and functional operation of the device at these or any other conditions beyond those indicated under "recommended operating conditions" is not implied. Exposure to absolute-maximum-rated conditions for extended periods may affect device reliability.

recommended operating conditions

		SN54HC153			SN74HC153			UNIT
		MIN	NOM	MAX	MIN	NOM	MAX	
V_{CC}	Supply voltage	2	5	6	2	5	6	V
V_{IH}	High-level input voltage	$V_{CC} = 2$ V	1.5		1.5		V	
		$V_{CC} = 4.5$ V	3.15		3.15			
		$V_{CC} = 6$ V	4.2		4.2			
V_{IL}	Low-level input voltage	$V_{CC} = 2$ V	0	0.3	0	0.3	V	
		$V_{CC} = 4.5$ V	0	0.9	0	0.9		
		$V_{CC} = 6$ V	0	1.2	0	1.2		
V_I	Input voltage	0	V_{CC}		0	V_{CC}		V
V_O	Output voltage	0	V_{CC}		0	V_{CC}		V
t_t	Input transition (rise and fall) times	$V_{CC} = 2$ V	0	1000	0	1000	ns	
		$V_{CC} = 4.5$ V	0	500	0	500		
		$V_{CC} = 6$ V	0	400	0	400		
T_A	Operating free-air temperature	-55	125	-40	85	°C		

electrical characteristics over recommended operating free-air temperature range (unless otherwise noted)

PARAMETER	TEST CONDITIONS	V_{CC}	$T_A = 25^\circ\text{C}$			SN54HC153		SN74HC153		UNIT
			MIN	TYP	MAX	MIN	MAX	MIN	MAX	
V_{OH}	$V_I = V_{IH}$ or V_{IL} , $I_{OH} = -20 \mu\text{A}$	2 V	1.9	1.998		1.9		1.9	V	
		4.5 V	4.4	4.499		4.4		4.4		
		6 V	5.9	5.999		5.9		5.9		
		4.5 V	3.98	4.30		3.7		3.84		
V_{OL}	$V_I = V_{IH}$ or V_{IL} , $I_{OL} = 20 \mu\text{A}$	2 V		0.002	0.1		0.1	0.1	V	
		4.5 V		0.001	0.1		0.1	0.1		
		6 V		0.001	0.1		0.1	0.1		
		4.5 V		0.17	0.26		0.4	0.33		
I_I	$V_I = V_{CC}$ or 0	6 V	± 0.1			± 100		± 1000		nA
		6 V	8			160		80		μA
I_{CC}	$V_I = V_{CC}$ or 0, $I_O = 0$	6 V	3			10		10		pF
C_i		2 to 6 V	3			10		10		pF



SN54HC153, SN74HC153 DUAL 4-LINE TO 1-LINE DATA SELECTORS/MULTIPLEXERS

switching characteristics over recommended operating free-air temperature range (unless otherwise noted), $C_L = 50$ pF (see Note 1)

PARAMETER	FROM (INPUT)	TO (OUTPUT)	V _{CC}	T _A = 25°C			SN54HC153		SN74HC153		UNIT
				MIN	TYP	MAX	MIN	MAX	MIN	MAX	
t _{pd}	A or B	Y	2 V		90	150		225		190	ns
			4.5 V		21	30		45		38	
			6 V		17	26		38		32	
t _{pd}	Data (Any C)	Y	2 V		73	126		189		158	ns
			4.5 V		17	28		42		35	
			6 V		14	23		35		29	
t _{pd}	G	Y	2 V		38	95		150		125	ns
			4.5 V		11	19		28		24	
			6 V		9	16		24		20	
t _t		Y	2 V		20	60		90		75	ns
			4.5 V		8	12		18		15	
			6 V		6	10		15		13	

C _{pd}	Power dissipation capacitance per multiplexer	No load, T _A = 25°C	40 pF typ
-----------------	---	--------------------------------	-----------

switching characteristics over recommended operating free-air temperature range (unless otherwise noted), $C_L = 150$ pF (see Note 1)

PARAMETER	FROM (INPUT)	TO (OUTPUT)	V _{CC}	T _A = 25°C			SN54HC153		SN74HC153		UNIT
				MIN	TYP	MAX	MIN	MAX	MIN	MAX	
t _{pd}	A or B	Y	2 V		105	235		355		295	ns
			4.5 V		27	47		71		59	
			6 V		21	41		60		51	
t _{pd}	Data (Any C)	Y	2 V		93	220		335		274	ns
			4.5 V		23	44		67		55	
			6 V		19	38		57		48	
t _{pd}	G	Y	2 V		60	185		280		230	ns
			4.5 V		17	37		56		46	
			6 V		14	32		48		40	
t _t		Y	2 V		45	210		315		265	ns
			4.5 V		17	42		63		53	
			6 V		13	36		53		45	

NOTE 1: Load circuit and voltage waveforms are shown in Section 1.