

The TQ8224 is a multi-configuration SONET/SDH OC48/STM16 CDR/DEMUX that regenerates and re-times serial 2.48832 Gb/s data. It recovers the 2.48832 GHz clock from the data stream and frequency divides it to generate control signals and clocks used to perform the demultiplexing function.

The TQ8224 operates in one of two different time-division demultiplexing modes, making it extremely flexible for telecom, ATM and networking applications. The serial 2.48832 Gb/s data stream can be demultiplexed into either an 8-bit wide 311.04 MHz data bus or a 16-bit wide 155.52 MHz data bus. Internal data inversion is also available. The device generates byte-wise parity check bits for the demultiplexed data and provides associated clock outputs for the different modes. Parity checking is not required for normal device operation.

The TQ8224 provides added flexibility through a selectable internal/external Voltage Controlled Oscillator(VCO) as well as a selectable internal Phase Locked Loop (PLL). If an external high frequency clock is utilized a single-ended or differential AC coupled clock may be used.

The internal PLL contains a NRZ phase detector which enables it to adjust the phase of the internal clock such that sampling of the incoming data stream occurs in the middle of the the data eye. An offset control allows adjustment ± 128 pS around this nominal position.

Operating from a single +5V supply, the TQ8224 provides fully compliant functionality and performance, utilizing direct-connected differential PECL (DPECL) levels for the 8 and 16 bit busses. The TQ8224 can also provide direct connection to high-speed output lines using ECL levels, if supplies are connected to -5.2V. However, with ECL operation, the TTL control signal grounds are referenced to -5.2V.

The TQ8224 is fully compliant with SONET/SDH jitter tolerance and transfer specifications. A TTL level LOCK signal is supplied to indicate when the frequency difference between the internal 38.88 MHz clock and the external 38.88 MHz clock is less than 488 ppm.

TQ8224

PRELIMINARY DATA SHEET

OC48/STM16 DEMUX/CDR with Differential Input

TELECOM
PRODUCTS

Features

- *Single-chip, 1:8 or 1:16 Demultiplexer with integrated clock and data recovery*
- *Differential Analog Data Input*
- *SONET/SDH compliant for 2.48832 Gb/s jitter tolerance & transfer*
- *Internal PLL with NRZ phase detector ensures sampling of incoming data stream occurs in center of data eye*
- *Static phase adjustment on recovered clock position*
- *High speed input data bit slipper for use in framing*
- *External RC-based loop filter*
- *Four output clock rates at 311.04, 155.52, 77.76, and 38.88 MHz.*
- *Internal byte-wise even/odd parity bit generator (mode programable)*
- *Direct-coupled differential PECL low-speed outputs*
- *23mm 208-pin BGA package*
- *5V single supply*
- *-40 to +125° C case operating temperature.*

TQ8224

PRELIMINARY DATA SHEET

Figure 1. TQ8224 Block Diagram

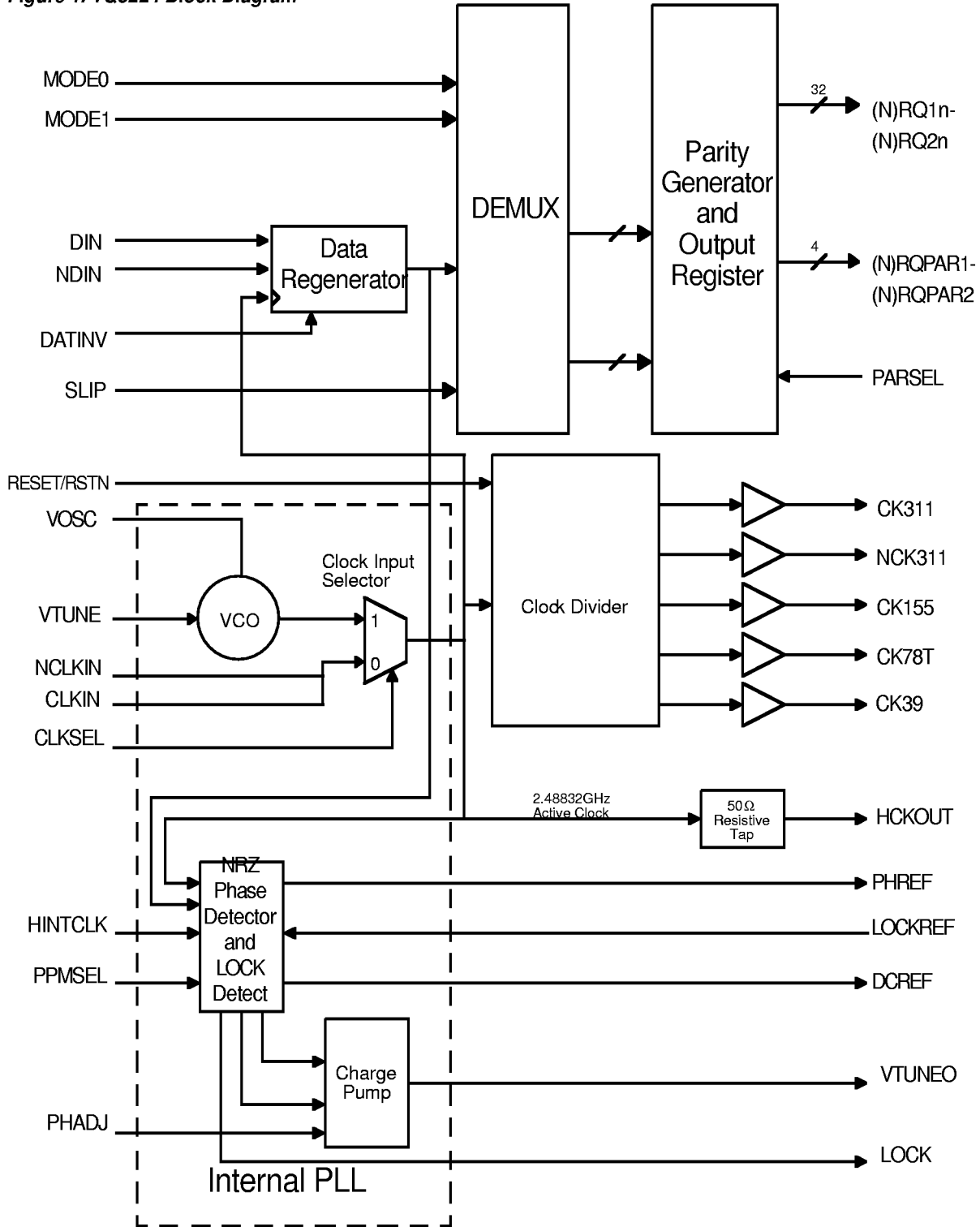

Function Description

Data Regeneration

The TQ8224 recovers and regenerates serial 2.48832 Gb/s data received at DIN and NDIN. The data recovery can be optimized by adjusting the input data re-timing clock phase at PHADJ. The PHADJ range is 2.5 +/- 0.5V. This corresponds to a centered sampling point when PHADJ is 2.5V and a -128 pS or +128 pS offset for 3V and 2V respectively. PHADJ must be externally supplied. See the figure below.

PHADJ Operation

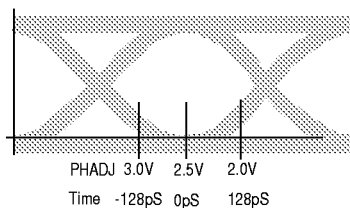

The regenerated data is then re-synchronized by re-timing it with the active 2.48832 GHz clock. (Negative edge triggered sampling is used.)

The regenerated data can be inverted by tying the DATINV pin to VEE.

Bit Slipper

The TQ8224 can slip a bit on the incoming data stream. An active low PECL pin, SLIP, causes the TQ8224 to skip over one incoming data bit. This can be done for framing purposes.

Timing Generation

The TQ8224 can receive an external 2.48832 GHz (nominal) reference clock or generate a 2.48832 GHz clock through an internal VCO. The output of the active clock can be monitored at HKCOUT which provides a 30mV_{pp} output.

Internal Clock VCO and PLL

Figure 10 contains a reference diagram of operation with the internal clock and PLL. The internal clock is

selected if the CLKSEL is tied to VDD and the external power supply pin, VOSC, is tied to VDD. CLKIN must be tied to VEE through a 10kΩ resistor when the internal clock is used.

The internal PLL is comprised of a NRZ phase detector, a charge pump, and the internal VCO. This NRZ phase detector's phase error signals are integrated by the Charge Pump block which then provides a VCO tune voltage at VTUNEO. The Charge Pump block requires external filter components which are connected at VTUNEO. See Table 5 for loop filter values. The internal PLL is completed by connecting VTUNEO to VTUNE. The purpose of the internal PLL is to adjust the phase of the internal VCO such that the negative edge of the internal sampling clock is in the center of the data eye. A phase offset can be added by adjusting the PHADJ input voltage. A 38.88 MHz PECL clock must be provided at HINTCLK to aid PLL acquisition.

The internal PLL provides an active high LOCK signal if the frequency difference between the internal VCO and the 38.88 MHz hint clock remains less than 488 ppm. If the frequency difference becomes greater than 488 ppm then the LOCK signal deasserts low. The LOCK signal will assert high when the frequency difference is less than 122 ppm or 30 ppm. This hysteresis set point is programmable and is determined by PPMSEL. When PPMSEL is tied to VEE the LOCK set point is 30 ppm, when PPMSEL is tied to VDD the LOCK set point is 122 ppm.

LOCK Signal Hysteresis

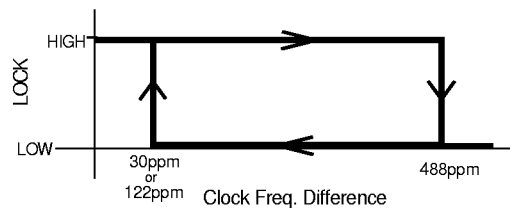
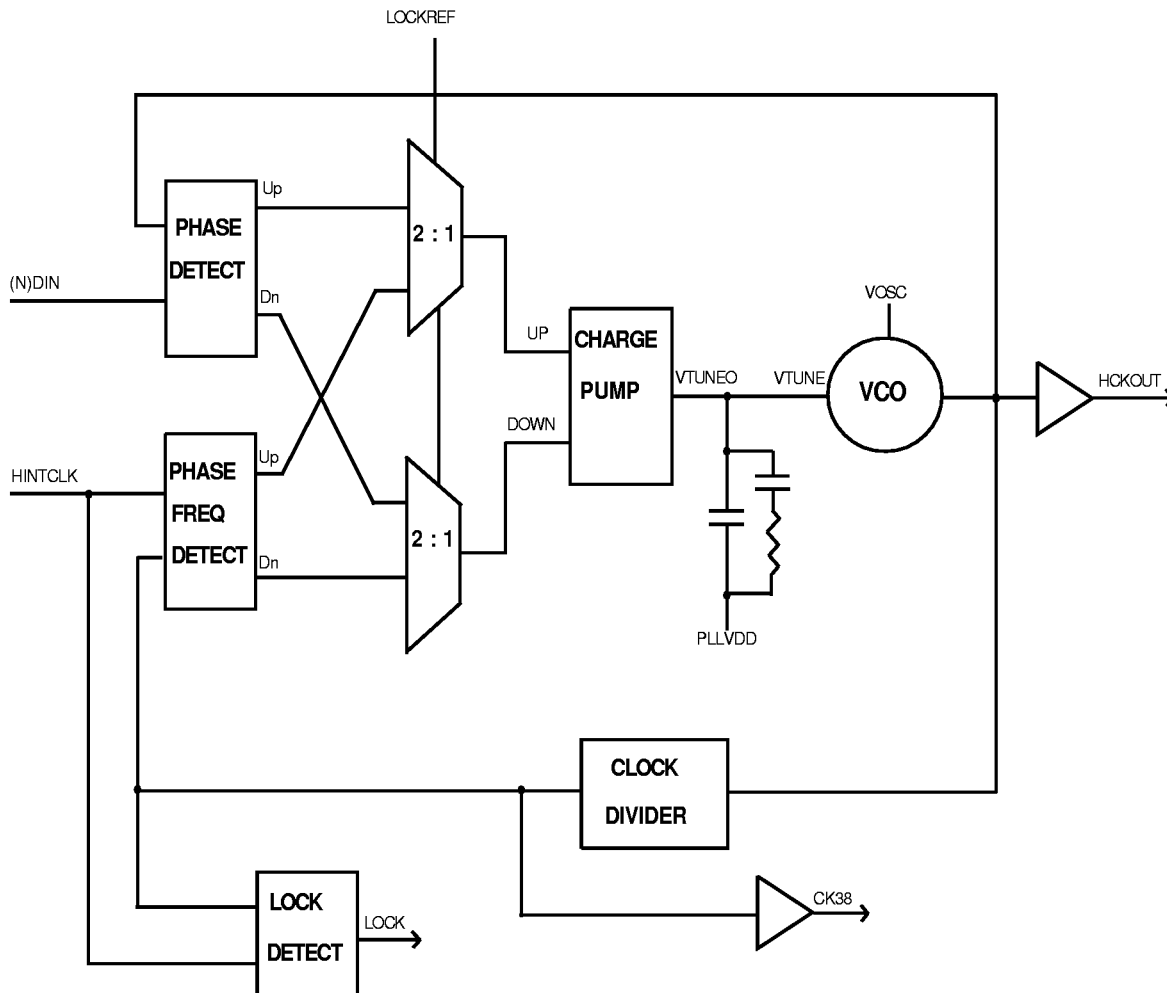

Figure 2. PLL and Lock Detector Block Diagram



External Clock VCO and PLL

See Figure 9 for a reference diagram of operation with an external clock and PLL. The received clock can be either single-ended or differential and is an AC coupled input on CKIN and NCKIN. The external clock is selected as the active clock if CLKSEL is tied to VEE. VOSC and VTUNE must be tied to VEE when using an external VCO. If the external clock is single ended the unused input must be externally terminated through a

capacitor to an AC ground. The internal NRZ phase detector generates PHREF and DCREF which, when connected to an external integrator, may be used to tune the external VCO.

Internal Clock VCO and External PLL

PHREF and DCREF must be connected to an external integrator. The output of the integrator is then connected to VTUNE, completing the PLL.

Output Clocks

The TQ8224 provides an internal Clock Divider which frequency divides the active 2.48832 GHz clock (internal or external source as selected by CLKSEL). The output of the Clock Divider supplies the internal clock signals necessary for the re-timing function and demultiplexing function. The Clock Divider block also outputs four external clocks: a differential 311.04 MHz PECL clock at CK311 and NCK311, a 155.52MHz PECL clock at CK155, a 77.76 MHz TTL clocks at CK78T, and a 38.88 MHz PECL clock at CK39. Note that the clock frequencies given above are dependant upon using the part at 2.48832 GHz.

Data Demultiplexer and Parity Generator

The TQ8224 can be configured to run in one of three modes. The demultiplexing modes are set by fixing the MODE1 and MODE0 package pins according to the following table.

MODE1	MODE0	Demultiplexing Mode
N.C.	N.C.	1:8
N.C.	VEE	1:16
VEE	VEE	ALL 1's OUTPUTS

For all modes the first high speed input bit in time appears on RQ11,NRQ11 which is the most significant bit. Subsequent input data is output sequentially to RQ12,NRQ12 through RQ28,NRQ28. Byte #1, RQ11,NRQ11-RQ18,NRQ18 is the most significant byte. Odd or even parity selection is programmable by PARSEL. If PARSEL is left open (N.C.) the parity is even. If PARSEL is tied to VEE the parity is odd.

In a 1:8 demultiplexing application, the TQ8224 regenerates the serial 2.48832 Gb/s data stream and re-times it with the negative edge of the active 2.48832 Ghz clock. The re-timed serial data stream is then 1:8 demultiplexed by the DEMUX block into an 8-bit wide

311.04 MHz data bus at RQ11,NRQ11-RQ18,NRQ18. A parity bit is generated for each byte, and transmitted in parallel to the data at RQPAR1,NRQPAR1. The 8-bit wide data plus one parity bit are then clocked out on the rising edge of the internally generated 311.04 MHz clock. See Figure 6.

In a 1:16 demultiplexing application, the TQ8224 regenerates the serial 2.48832 Gb/s data stream and re-times it with the negative edge of the active 2.48832 Ghz clock. The re-timed serial data stream is then 1:16 demultiplexed by the DEMUX block into an 16-bit wide 155.52 MHz data bus at RQ11,NRQ11-RQ28,NRQ28. A parity bit is generated for each byte, and transmitted in parallel to the data at RQPAR1,NRQPAR1 and RQPAR2,NRQPAR2. The 16-bit wide data plus two parity bits are then clocked out on the rising edge of the internally generated 155.52 MHz clock. See Figure 7.



TQ8224

PRELIMINARY DATA SHEET

Figure 3. TQ8224 Pinout - Top View

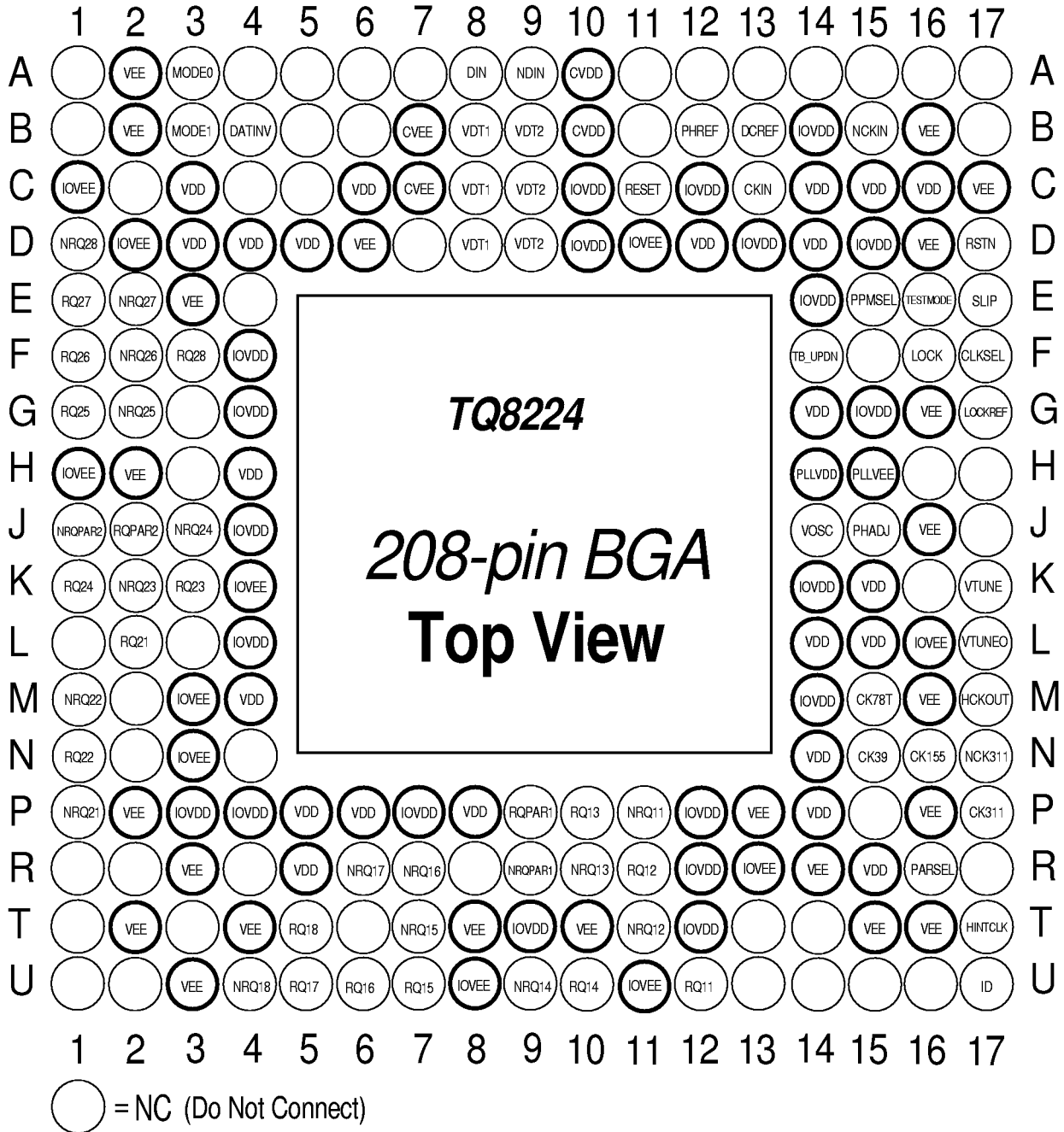

Note: Heat Spreader is at VDD volts.

Table 1. Signal Description

Pin No.	Grid Ref.	Signal	Type & Freq/Bit Rate	Description
<i>Data Demultiplexing Configuration</i>				
50	A3	MODE0	Input DC	(MODE1 = N.C., MODE0 = N.C.) = 1:8 demultiplexing;
49	B3	MODE1	Input DC	(MODE1 = N.C., MODE0 = VEE) = 1:16 demultiplexing; (MODE1 = VEE, MODE0 = VEE) = all 1's output.
<i>2.5Gb/s Input Interface</i>				
30	A8	DIN	Input AC 2.48832 Gb/s	High speed differential data input. Must be AC coupled.
29	A9	NDIN		The input is internally terminated by $R_T \Omega$ to $V_{TD1,2}$.
26,27,28	B9,C9,D9	VTD2	Input Analog DC	Input signal termination voltage, nominally at $V_{DD}-2.8V$.
31,32,33	B8,C8,D8	VTD1	Input Analog DC	
46	B4	DATINV	Input Analog DC	DIN complement select signal. N.C. = true; VEE = complement
<i>311.04Mb/s and 155.52Mb/s Interface</i>				
142	U12	RQ11	Output DPECL 311.04 MHz or 155.52 MHz	Byte #1. Most significant Byte (MSB). Parallel data bit. RQ11,NRQ11 is the most significant bit.
141	P11	NRQ11	Output DPECL	Parallel data bit
140	R11	RQ12	Output DPECL	Parallel data bit
139	T11	NRQ12	Output DPECL	Parallel data bit
136	P10	RQ13	Output DPECL	Parallel data bit
135	R10	NRQ13	Output DPECL	Parallel data bit
134	U10	RQ14	Output DPECL	Parallel data bit
133	U9	NRQ14	Output DPECL	Parallel data bit
125	U7	RQ15	Output DPECL	Parallel data bit
124	T7	NRQ15	Output DPECL	Parallel data bit
123	U6	RQ16	Output DPECL	Parallel data bit
122	R7	NRQ16	Output DPECL	Parallel data bit
119	U5	RQ17	Output DPECL	Parallel data bit
118	R6	NRQ17	Output DPECL	Parallel data bit
117	T5	RQ18	Output DPECL	Parallel data bit
116	U4	NRQ18	Output DPECL	RQ18,NRQ18 is the least significant bit of Byte#1
131	P9	RQPAR1	Output DPECL	Parity bit signal for the 8-bit wide data at RQ11,NRQ11 to RQ18,NRQ18 The parity bit is simultaneous with the byte wide data from which it was calculated.
130	R9	NRQPAR1	Output DPECL	Complement of RQPAR1

TQ8224

PRELIMINARY DATA SHEET

Table 1. Signal Description (continued)

Pin No.	Grid Ref.	Signal	Type and Freq. or Bit Rate	Description
90	L2	RQ21	Output DPECL 155.52 Mb/s	Byte #2 RQ21,NRQ21 is the most significant bit.
89	P1	NRQ21	Output DPECL	Parallel data bit
88	N1	RQ22	Output DPECL	Parallel data bit
87	M1	NRQ22	Output DPECL	Parallel data bit
84	K3	RQ23	Output DPECL	Parallel data bit
83	K2	NRQ23	Output DPECL	Parallel data bit
82	K1	RQ24	Output DPECL	Parallel data bit
81	J3	NRQ24	Output DPECL	Parallel data bit
73	G1	RQ25	Output DPECL	Parallel data bit
72	G2	NRQ25	Output DPECL	Parallel data bit
71	F1	RQ26	Output DPECL	Parallel data bit
70	F2	NRQ26	Output DPECL	Parallel data bit
67	E1	RQ27	Output DPECL	Parallel data bit
66	E2	NRQ27	Output DPECL	Parallel data bit
65	F3	RQ28	Output DPECL	Parallel data bit
64	D1	NRQ28	Output DPECL	RQ28,NRQ28 is the least significant bit of the LSB (Byte#2)
79	J2	RQPAR2	Output DPECL	Parity bit signal for the 8-bit wide data at RQ21,NRQ21 to RQ28,NRQ28 The parity bit is simultaneous with the byte wide data from which it was calculated.
78	J1	NRQPAR2	Output DPECL	Complement of NRQPAR2
170	P17	CK311	Output PECL 311.04 MHz	311.04 MHz differential clock output. Must be externally terminated by $R_{TE} \Omega$ to V_{TTE} .
171	N17	NCK311	Output PECL 311.04 MHz	Complement of CK311 Must be externally terminated by $R_{TE} \Omega$ to V_{TTE} .
169	N16	CK155	Output PECL 155.52 MHz	155.52 MHz clock output.
168	M15	CK78T	Output TTL 77.76 MHz	77.76 MHz clock output.
167	N15	CK39	Output PECL 38.88 MHz	38.88 MHz clock output.
<i>Phase-locked Loops Elements</i>				
182	J14	VOOSC	Analog Power Supply	Analog power supply for the internal VCO. VEE = VCO OFF; VDD = VCO ON
181	K17	VTUNE	Input Analog	Frequency tune voltage for internal VCO. Negative tune slope. Must be tied to VEE when using an external VCO.
8	C13	CKIN	Input AC 2.48832 GHz	High frequency clock input. The differential inputs must be AC coupled and externally terminated by $R_{TE} \Omega$ to V_{TTE} . Must be externally terminated by 10kΩ to VEE when internal VCO is used.
7	B15	NCKIN	Input AC 2.48832 GHz	Complement of CKIN. Must be left open when internal VCO is used.

Table 1. Signal Description (continued)

Pin No.	Grid Ref.	Signal	Type and Freq. or Bit Rate	Description
164	T17	HINTCLK	Input PECL	38.88 MHz PECL hint clock to aid PLL acquisition.
176	M17	HCKOUT	Output AC 2.48832 GHz	High speed clock monitor. 30mVpp with a 50Ω load.
199	F17	CLKSEL	Input DC	Clock select signal for choosing between external or internal clock source as the active clock. NC = Internal VCO; V _{EE} = External VCO. When external VCO is chosen, the internal VCO is forced to a fixed logic state even if powered.
12	B12	PHREF	Output Analog	Phase detector output. Requires external pull-up resistor to V _{DD} .
11	B13	DCREF	Output Analog	Phase detector reference output. Requires external pull-up resistor to V _{DD} .
183	J15	PHADJ	Input Analog	Phase detector static offset. Nominally at 2.5V. The full range of 2.5 +/- 1.25 V produces a +/-128 ps offset between the center of the data eye and the falling edge of the sampling clock.
180	L17	VTUNEO	Output Analog	Internal PLL charge pump output.
194	F16	LOCK	Output TTL	Internal PLL lock detector. Remains high when frequency difference between internal and external reference clocks is less than 488 ppm. Accuracy of LOCK detect circuitry is related to the accuracy of the external HINTCLK. Can be tied to LOCKREF.
195	G17	LOCKREF	Input TTL	Forces internal PLL to lock to external reference clock when LOCKREF is low.
200	E15	PPMSEL	Input TTL	LOCK signal lower hysteresis level. When PPMSEL=VDD the LOCK signal will return to a high state when the frequency difference between the internal and external reference clocks is less than 122 ppm. When PPMSEL=VEE the LOCK will return to a high state when the frequency difference is less than 30 ppm from HINTCLK.
<i>Power Pins and Test Pins</i>				
202	D17	RSTN	Input PECL	Chip reset (active low) Normally tied to RESET. When not used must be tied to VDD through R_{Te}Ω
201	E17	SLIP	PECL	Slips demultiplexer 1 Bit at each negative edge, can be used once every 3ns. When not used must be tied to VTT.
162	R16	PARSEL	TTL	When PARSEL=N.C. parity bits generated are even. When PARSEL=VEE parity bits generated are odd.
14	C11	RESET	Input PECL	High speed reset allows for multiple demux synchronization. Normally tied to RSTN. When not used must be tied to VDD through R_{Te}Ω
159	U17	ID	Output Analog	Part level identification. Voltage at ID indicates device type. ID=##
197	F14	TB_UPDN	Factory Test	For testing purposes only. Must be tied to VEE.

TQ8224

PRELIMINARY DATA SHEET

Table 1. Signal Description (continued)

Pin No.	Grid Ref.	Signal	Type and Freq. or Bit Rate	Description					
198	E16	TESTMODE	Factory Test	For testing purposes only. Must be tied to VEE.					
24,25	A10,B10	CVDD	Analog Power Supply	Differential Data Input positive supply voltage					
35,36	B7,C7	CVEE	Analog Power Supply	Differential Data Input supply return					
187	H14	PLLVD	Analog Power Supply	PLL positive supply voltage					
188	H15	PLLVEE	Analog Power Supply	PLL supply return.					
Signal	Description	Pin Number,Grid Reference							
VDD	Positive rail supply voltage	6,C14	9,D12	42,C6	48,D5	54,C3	55,D3	53,D4	
		74,H4	94,M4	109,P5	113,R5	114,P6	126,P8	158,R15	
		157,P14	161,N14	172,L14	173,L15	178,K15	192,G14	206,D14	
		207,C15	208,C16						
IOVDD	I/O Positive supply voltage	5,D13	10,B14	13,C12	21,C10	20,D10	62,F4	68,G4	
		91,L4	80,J4	132,T9	104,P3	120,P7	143,T12	146,P12	
		166,M14	177,K14	191,G15	203,E14	204,D15	103,P4	147,R12	
VEE	Negative rail supply voltage	105,R3	106,T2	112,U3	115,T4	128,T8	153,P13	154,R14	
		155,T15	156,T16	163,P16	174,M16	184,J16	102,P2	193,G16	
		205,D16	1,B16	2,C17	43,D6	51,A2	52,B2	61,E3	
		76,H2	137,T10						
IOVEE	I/O Negative supply voltage	101,N3	93,M3	129,U8	138,U11	150,R13	175,L16	15,D11	
		63,C1	60,D2	77,H1	85,K4				
NC	DO NOT CONNECT	3,B17	16,A15	17,A14	18,A13	19,A12	22,B11	23,A11	
		40,B6	41,B5	56,A1	57,E4	58,B1	59,C2	69,G3	
		75,H3	86,L1	92,L3	95,R1	96,M2	97,T1	98,N2	
		99,R2	100,N4	107,U1	108,U2	110,R4	111,T3	121,T6	
		127,R8	148,T13	149,T14	151,U15	152,U16	165,R17	196,F15	
		47,C4	160,P15	34,A7	144,U13	145,U14	186,H17	185,J17	
		39,A5	38,D7	4,A16	44,C5	45,A4	179,K16	189,H16	
		37,A6	190,A17						

Table 2. Absolute Maximum Ratings

Parameter	Symbol	Min	Max	Unit
Supply voltage	VDD-VEE	GND	7.0	V
Internal VCO Supply voltage	VOOSC	VEE-0.5	VDD+0.5	V
DIN ,NDIN termination voltage	VTD	VEE-0.5	VDD+0.5	V
Inputs/Outputs		VEE-0.5	VDD+0.5	V
Storage Temperature	Tstg	-55	150	°C
Maximum Case Operating Temperature, Tc			125	°C
Maximum junction temperature Tj			150	°C
Electrostatic Discharge (100 pF, 1.5 kΩ)			1000	V

Table 3. DC Operating Ranges (PECL Operation)

Signal	Symbol	Parameter	Min	Typ	Max	Units
VDD-VEE (Note 1)	$V_{DD}-V_{EE}$	Supply voltage range	4.75	5.00	5.46	V
VOSC (Note 1)	V_{osc}	Internal VCO supply	-	VDD	-	V
	I_{osc}	Supply current for internal VCO		14		mA
PLLVD-PLLVEE (Note 1)	$P_{VDD}-P_{VEE}$	PLL supply voltage	-	VDD	-	V
	I_{PLL}	Supply current for internal VCO			40	mA
VTD (Note 1)	V_{TD}	V_{TD} supply voltage range		VDD-2.8		V
	I_{TD}	V_{TD} termination supply current (Note 2)			30	mA
	R_{TD}	DIN/NDIN Termination resistance	45	50	55	Ω
CVDD-CVEE (Note 1)	$C_{VDD}-C_{VEE}$	Input Comparator supply voltage	-	VDD	-	V
	I_{PLL}	Supply current for internal VCO			20	mA
	T_c	Case temperature	-40		125	$^{\circ}C$

- Notes:
1. No special power up sequence is required.
 2. VEE ,VTD at operating range.

Table 4. Power Dissipation

Low Speed Outputs	VDD (V)	Typ Power (W)	Max Power (W)
Open	5.0	3.30	3.52
Open	5.25	4.10	4.29
Fully Loaded	5.0	3.91	4.17

Table 5. Recommended External Loop Filter Values

REFCLK Frequency (MHz)	Resistor Value R1 (Ω)	Capacitor Value C1 (μF)	Capacitor Value C2 (pF)
38.88	68	0.33	133

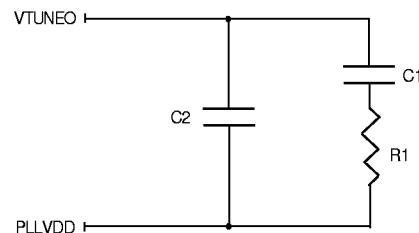

Table 6. VCO Control Signal Specifications

Signal	Symbol	Parameter	Min	Typ	Max	Units
VTUNEO	V_{range}	VTUNEO voltage range (Note 1)		2.5		V
	KVCO	VCO VTUNE voltage gain		500		MHz/V
	f_{range}	VCO frequency range when using internal PLL		1950 - 2700		MHz

- Notes:
1. A VTUNEO voltage of 2.5V corresponds to approximately a 2.5GHz center frequency.

TQ8224

PRELIMINARY DATA SHEET

Table 7. High Speed Signal Specification

Signal	Symbol	Description	Min	Nom (Note 1)	Max	Units
CLKIN	t_{cki}	Input clock period	370.4 ps	401.88 ps	250 ns	
NCLKIN	t_{ckdc}	Input clock duty cycle	40	50	60	%
	V_{amp}	Input clock differential peak to peak voltage	1000	1200	1400	mV
HCKOUT	t_{cko}	High speed output clock period	-	401.88	-	ps
	V_{amp}	High speed output clock peak-to-peak voltage	10	-	-	mV _{pp}
	R_{Te}	High speed output clock output impedance	45	50	55	Ω

Note 1: All NOM specifications apply under the following conditions.
 Input data pattern: $2^{23} - 1$ PRBS
 Input data rate: 2.48832 Gbps
 Input clock frequency: 2.48832 GHz
 Input data rise/fall time (20%/80%) >100 p

Table 8. Jitter Generation Performance

Signal	Jitter Generation	Nom	Max	Units
CK155	J_{pp}	6.2		ps
	J_{RMS}	0.84		ps

Note: The method used is outlined in a Jitter Bench Application Note available upon request. The values listed as nominal were performed under the following conditions: Data Rate = 2.48832 Gb/s
 VDD = 5 V
 Tcase = 60 C

Table 9. Jitter Tolerance Performance

Symbol	Description
$J_{tolerance}$	The TQ8224 CDR exceeds the SONET/SDH Jitter Tolerance Template according to the figure below.

Note: The method used to measure Jitter Tolerance is outlined in a Jitter Bench application note available upon request.

Figure 4. Jitter Tolerance

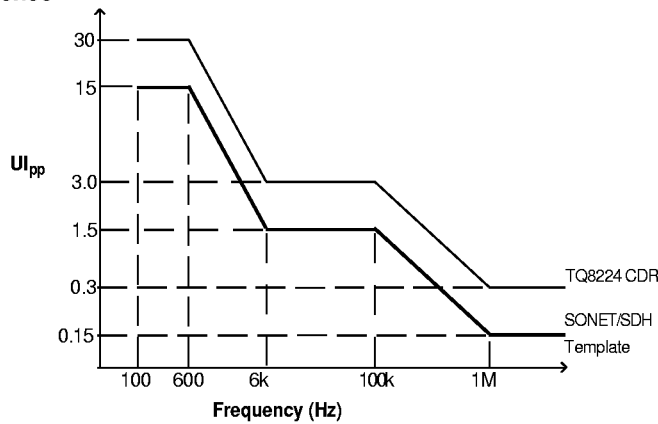

Table 10. Jitter Transfer Performance

Symbol	Description	Nom	Max	Units
J_{peaking}	Peak Gain in Transfer Curve	0.05	0.1	dB
f_c	Corner Frequency Transfer Curve	1.76	2.0	MHz

Note: Jitter Transfer measurements were performed with the PLL loop filter values specified in Table 5. The method used is outlined in a Jitter Bench application note available upon request. The values listed as nominal were performed under the following conditions: VDD = 5 V
Tcase = 60 C



Figure 5. Typical Jitter Transfer Curve

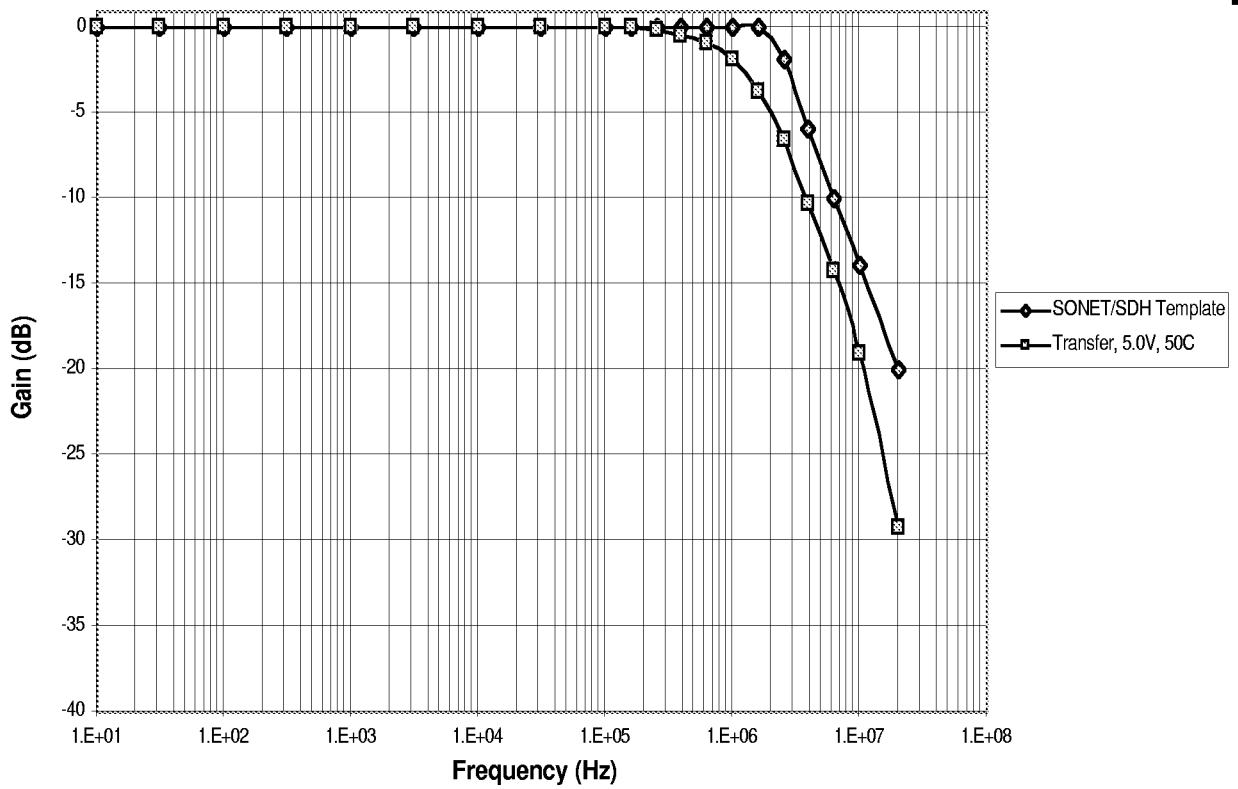

TQ8224

PRELIMINARY DATA SHEET

Table 11. Data Channel Specifications (Note 4)

Signal	Symbol	Description	Min	Nom	Max	Units
DIN	V_{dp-p}	(N)DIN outer eye differential pk-pk amplitude		1000	1600	mV _{pp}
NDIN		(N)DIN data rate		2.48832		Gb/s
	V_{sens}	Data channel sensitivity (Note 1)	40			mV
	V_{off}	(N)DIN differential offset voltage	-25		+25	mV
	T_{dead}	Data channel dead band (Note 2)			125	ps
	V_{hys}	Data channel hysteresis (Note 3)			5	mV

Note 1: Measured as the minimum inner eye amplitude of the data signal at DIN that can be correctly regenerated. Input clock/data phase and Data decision threshold optimized for sensitivity.

All specifications apply under the following conditions.

Input data pattern: $2^{23}-1$ PRBS
 Input data rate: 2.48832 Gbps
 Input clock frequency: 2.48832 GHz
 Input data rise/fall time (20%/80%) >100 ps

Note 2: Measured as the input clock/data phase range over which errors can be detected at RQ11-18 in 1:8 mode. Specification applies under the following conditions:

- input data amplitude: < 375mV mean¹-mean⁰
 - Input data rise/fall time (20%/80%) >100 ps

Note 3: Hysteresis is the difference in the decision threshold that results in error free operation of the channel when the decision threshold is first increased and then decreased and vice versa starting from a level that results in error free operation of the channel. The hysteresis specification applies for both the '1' and '0' signal levels. The DIN input conditions are the same as those listed in note 1 above.

Note 4: All amplitudes are differential peak-peak voltage

Table 12. TTL Interface Specifications

Signal	Symbol	Description	Min	Nom	Max	Units
CK78T	tckdc	Output clock duty cycle (Note 1)	40	50	60	%
	tckr	Output clock rise time (20% to 80%)			2000	ps
	tckf	Output clock fall time (20% to 80%)			2000	ps
	Voh	Output clock high level	2.4		V_{DD}	V
	Vol	Output clock low level	V_{EE}		0.4	V
	Cload	Output load capacitance		20		pF
LOCK	Voh	Output high voltage	2.4		V_{DD}	V
	Vol	Output low voltage	V_{EE}		0.4	V
	Ioh	Output high-level output current		50		mA
	Iol	Output low-level output current		-20		mA
	Cload	Output load capacitance		20		pF
LOCKREF	Vih	Input high level	2.0		V_{DD}	V
PPMSEL	Vil	Input low level	V_{EE}		0.8	V
MODE(0:1)						
PARSEL						

Notes: 1. Output clock duty cycle is measured at the mean voltage of the signal and nominal input clock frequency of 2.48832GHz.

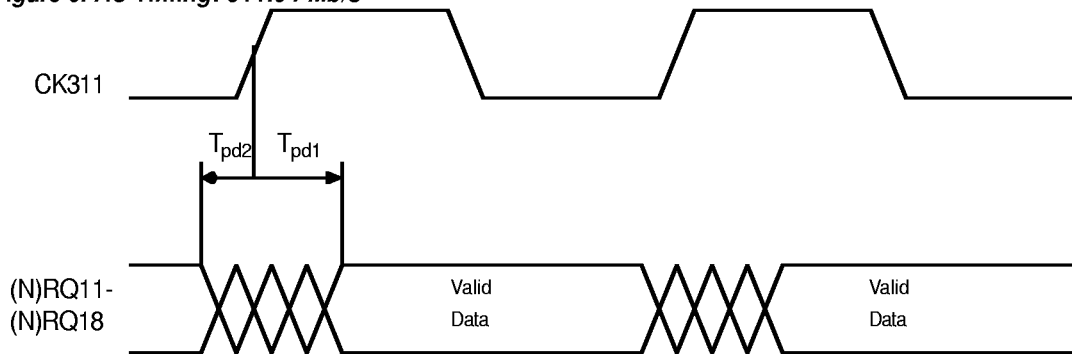

Table 13. PECL Interface Specifications

Signal	Symbol	Description	Min	Nom	Max	Units
CK311	tckdc	Output clock duty cycle (Note 4)	40	50	60	%
NCK311	tckr	Output clock rise time (20% to 80%)			750	ps
CK155	tckf	Output clock fall time (20% to 80%)			750	ps
CK39	Voh	Output clock high level	$V_{DD}-1.0$	-	$V_{DD}-0.6$	V
(Note 1)	Vol	Output clock low level	V_{TTe}	-	$V_{DD}-1.6$	V
	Vamp	Output clock amplitude (Note 5)	+/-350	-	-	mV
(N)RQ11-	Tpd1	311Mb/s output data delay 1 (Note 2)			1000	ps
(N)RQ28	Tpd1	155Mb/s output data delay 1 (Note 2)			1550	ps
RQPAR1,	Tpd2	Output data hold time (Note 2)			0	ps
NRQPAR1	Voh	Output data high voltage (Note 3)	$V_{DD}-1.0$		$V_{DD}-0.6$	V
RQPAR2,	Vol	Output data low voltage (Note 3)	V_{TTe}		$V_{DD}-1.6$	V
NRQPAR2	tdor	Output data rise time (20% to 80%)			750	ps
	tdof	Output data fall time (80% to 20%)			750	ps
SLIP	Vih	Input high level (Note 3)	$V_{DD}-1.05$		$V_{DD}-0.4$	V
RESET	Vil	Input low level (Note 3)	V_{TTe}		$V_{DD}-1.55$	V
RSNT	tif	Input fall time (20% to 80%)			750	ps
HINTCLK	tif	Input fall time (20% to 80%)			750	ps

- Notes:
1. All specifications apply with signals terminated with R_{Te} Ω to V_{TTe} .
 2. See Figure 6 and Figure 7. Tpd1 and Tpd2 are specified relative to the falling edge of the CK311 or the CK155 (mode dependant) signal. Output data edge jitter is not included in the specifications. The output data streams are assumed to be free of any skewing in time. The specifications apply under the following conditions:
 - Output data rise/fall time: $\leq 2000ps$ (20% to 80%)
 - Output data: $2^{23}-1$ PRBS, 16x155Mb/s or 8x311Mb/s
 - Output clock frequency: 155.52 MHz or 311.04 MHz
 3. Data level requirements apply under the following condition:
 - Data termination: R_{Te} to V_{TTe}
 4. Output clock duty cycle is measured at the mean voltage of the signal and nominal input clock frequency of 2.48832 GHz.
 5. The output clock output amplitude is measured with respect to the mean voltage of the signal.

Figure 6. AC Timing: 311.04 Mb/s



TQ8224

PRELIMINARY DATA SHEET

Figure 7. AC Timing: 155.52 Mb/s Interface

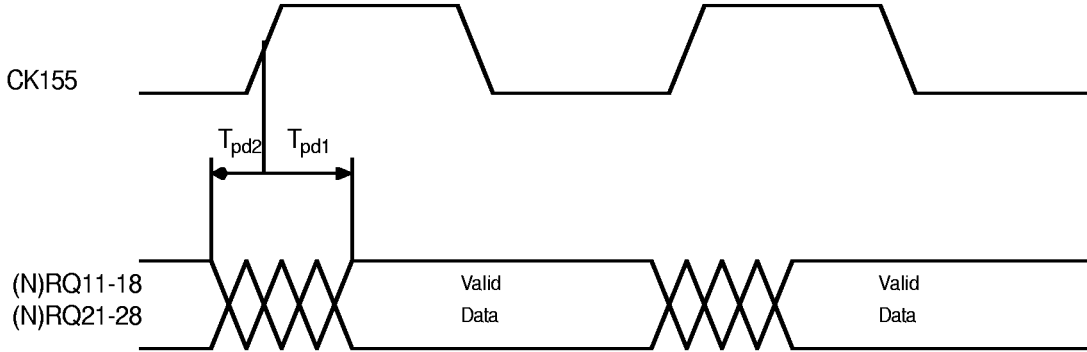

Figure 8. Output Clock Timing Relationships

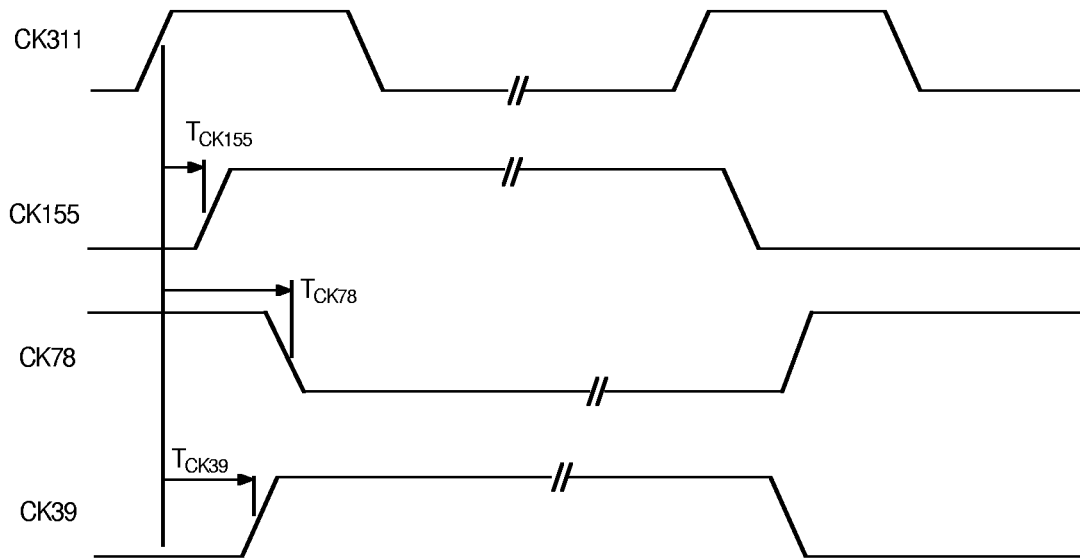
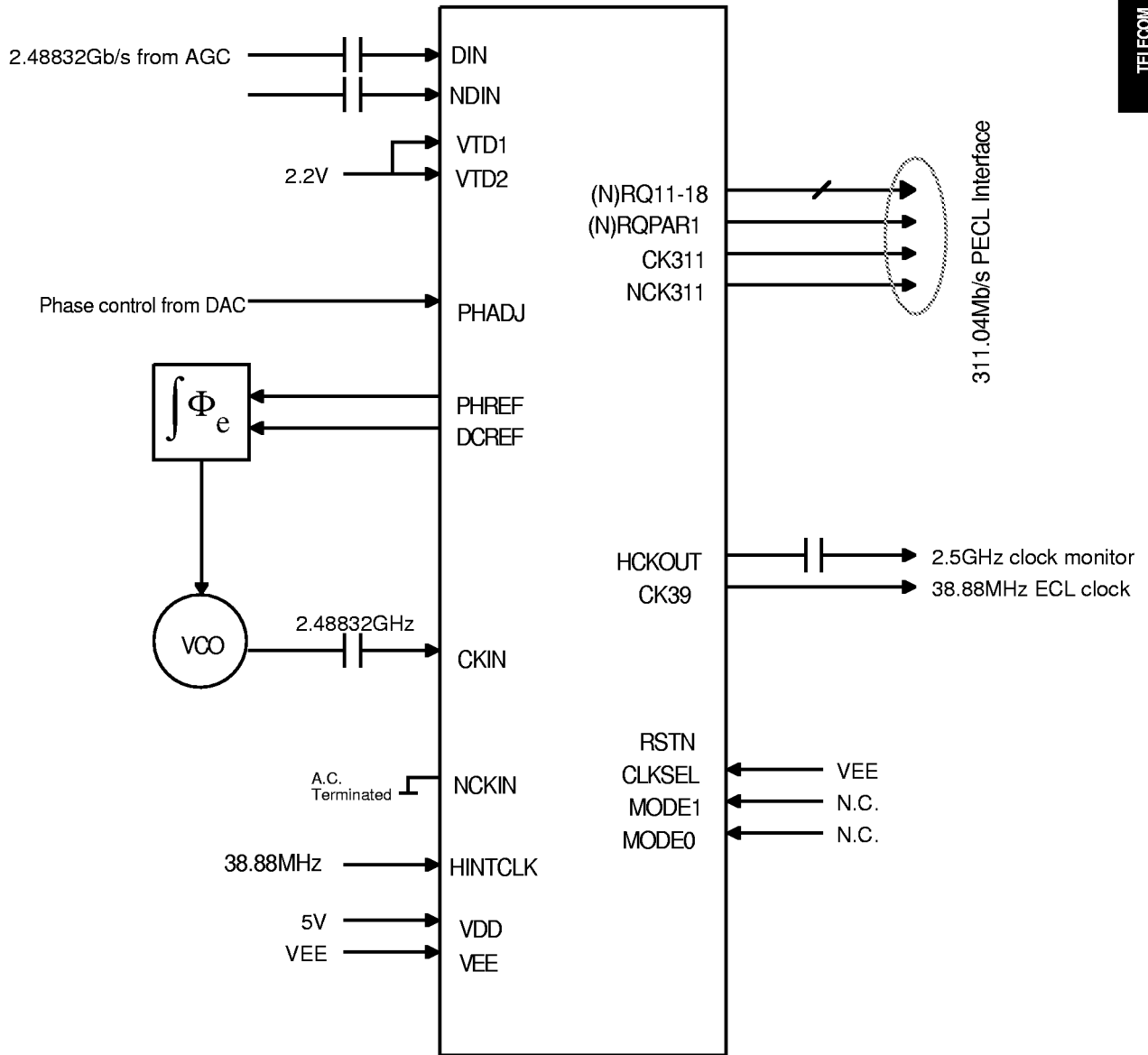

Table 14. Output Clock Timing Relationships

Symbol	Description	Typ	Max	Units
T_{CK155}	CK311 to CK155 timing relation	225		pS
T_{CK78}	CK311 to CK78 timing relation	1400		pS
T_{CK39}	CK311 to CK39 timing relation	770		pS

Typical Application

Figure 9. 1:8 Demultiplexing with External PLL and VCO



TQ8224

PRELIMINARY DATA SHEET

Figure 10. 1:16 Demultiplexing with Internal PLL

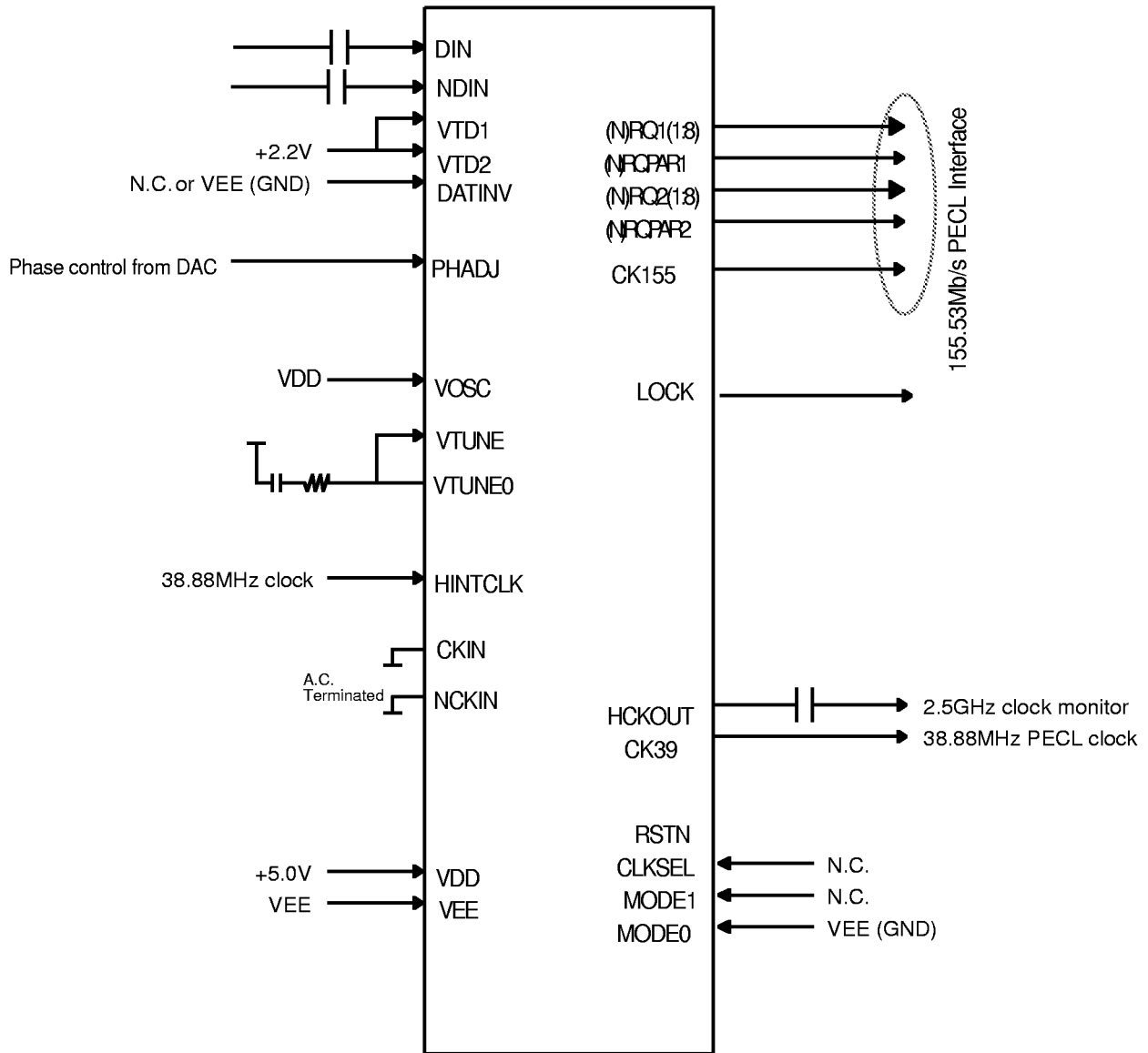

Figure 11. 208-pin BGA Mechanical Dimensions

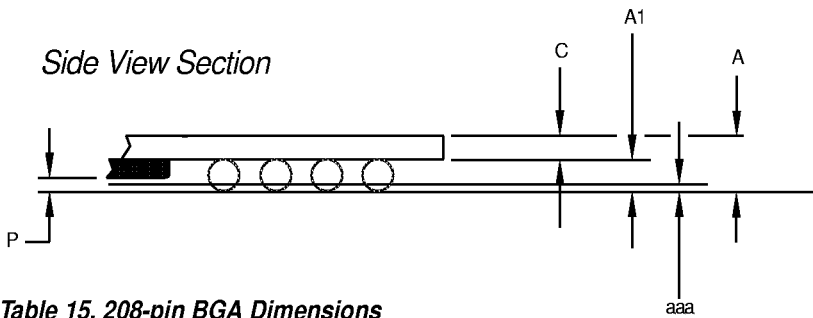
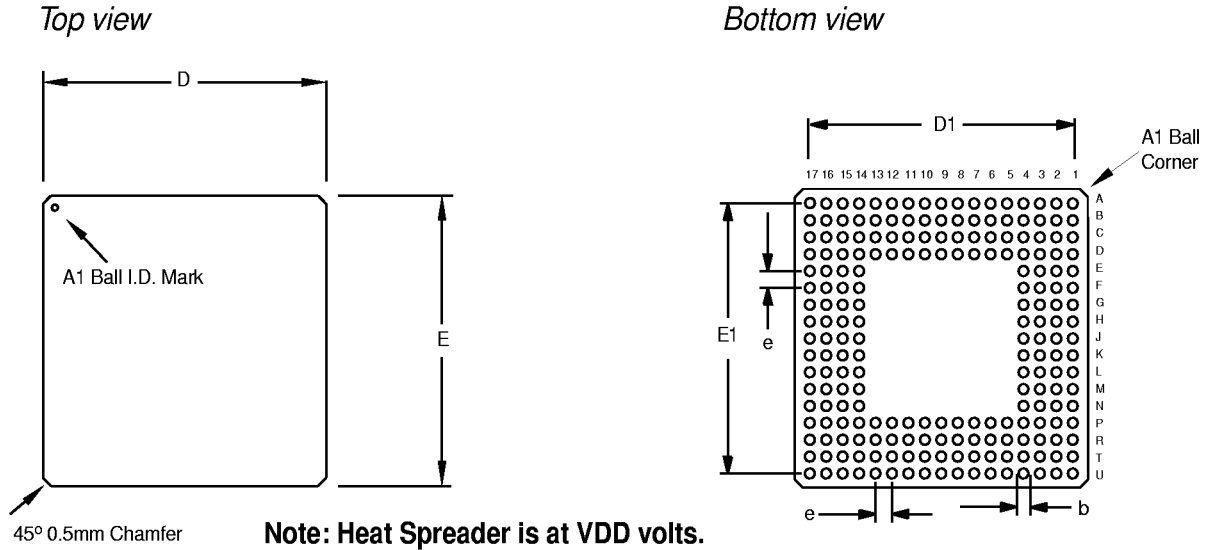

Table 15. 208-pin BGA Dimensions

Symbol	Parameter	Min	Nom	Max
A	Overall Thickness	1.45	1.55	1.65
A1	Ball Height	0.60	0.65	0.70
D	Body Size	22.80	23.00	23.20
D1	Ball Footprint	20.32 (BSC.)		
E	Body Size	22.80	23.00	23.20
E1	Ball Footprint	20.32 (BSC.)		
b	Ball Diameter	0.65	0.75	0.85
c	Body Thickness	0.85	0.90	0.95
aaa	Seating Plane Clearance	0.15		
e	Ball Pitch	1.27 TYP.		
P	Encapsulation Clearance	0.15		

Note: All dimensions in millimeters (mm)