

VSC8530-04 Datasheet
Single Port Industrial Grade Fast Ethernet Copper PHY
with RGMII/RMII Interfaces



a  MICROCHIP company



Microsemi Headquarters

One Enterprise, Aliso Viejo,
CA 92656 USA

Within the USA: +1 (800) 713-4113

Outside the USA: +1 (949) 380-6100

Sales: +1 (949) 380-6136

Fax: +1 (949) 215-4996

Email: sales.support@microsemi.com

www.microsemi.com

©2017–2018 Microsemi, a wholly owned subsidiary of Microchip Technology Inc. All rights reserved. Microsemi and the Microsemi logo are registered trademarks of Microsemi Corporation. All other trademarks and service marks are the property of their respective owners.

Microsemi makes no warranty, representation, or guarantee regarding the information contained herein or the suitability of its products and services for any particular purpose, nor does Microsemi assume any liability whatsoever arising out of the application or use of any product or circuit. The products sold hereunder and any other products sold by Microsemi have been subject to limited testing and should not be used in conjunction with mission-critical equipment or applications. Any performance specifications are believed to be reliable but are not verified, and Buyer must conduct and complete all performance and other testing of the products, alone and together with, or installed in, any end-products. Buyer shall not rely on any data and performance specifications or parameters provided by Microsemi. It is the Buyer's responsibility to independently determine suitability of any products and to test and verify the same. The information provided by Microsemi hereunder is provided "as is, where is" and with all faults, and the entire risk associated with such information is entirely with the Buyer. Microsemi does not grant, explicitly or implicitly, to any party any patent rights, licenses, or any other IP rights, whether with regard to such information itself or anything described by such information. Information provided in this document is proprietary to Microsemi, and Microsemi reserves the right to make any changes to the information in this document or to any products and services at any time without notice.

About Microsemi

Microsemi, a wholly owned subsidiary of Microchip Technology Inc. (Nasdaq: MCHP), offers a comprehensive portfolio of semiconductor and system solutions for aerospace & defense, communications, data center and industrial markets. Products include high-performance and radiation-hardened analog mixed-signal integrated circuits, FPGAs, SoCs and ASICs; power management products; timing and synchronization devices and precise time solutions, setting the world's standard for time; voice processing devices; RF solutions; discrete components; enterprise storage and communication solutions, security technologies and scalable anti-tamper products; Ethernet solutions; Power-over-Ethernet ICs and midspans; as well as custom design capabilities and services. Learn more at www.microsemi.com.

Contents

1	Revision History	1
1.1	Revision 4.1	1
1.2	Revision 4.0	1
2	Overview	2
2.1	Key Features	2
2.1.1	Superior PHY and Interface Technology	2
2.1.2	Fast Link Up/Link Drop Modes	2
2.1.3	Best-in-Class Power Consumption	2
2.1.4	Key Specifications	2
2.2	Block Diagram	3
3	Functional Descriptions	4
3.1	Operating Modes	4
3.2	MAC Interface	4
3.2.1	RGMIIC MAC Interface Mode	4
3.2.2	RMII Mode	5
3.2.3	MAC Interface Edge Rate Control	7
3.3	Hardware Mode Strapping and PHY Addressing	8
3.3.1	CLKOUT Signal Configuration	8
3.3.2	Managed Mode	8
3.3.3	Unmanaged Mode	9
3.4	Cat5 Twisted Pair Media Interface	10
3.4.1	Voltage Mode Line Driver	10
3.4.2	Cat5 Auto-Negotiation and Parallel Detection	10
3.4.3	Automatic Crossover and Polarity Detection	10
3.4.4	Manual MDI/MDIX Setting	11
3.4.5	Energy-Efficient Ethernet	11
3.5	Reference Clock	12
3.6	Ethernet Inline-Powered Devices	13
3.7	IEEE 802.3af Power-over-Ethernet Support	14
3.8	ActiPHY Power Management	14
3.8.1	Low Power State	15
3.8.2	Link Partner Wake-Up State	15
3.8.3	Normal Operating State	15
3.9	Serial Management Interface	15
3.9.1	SMI Frames	16
3.9.2	SMI Interrupt	16
3.10	LED Interface	17
3.10.1	LED Modes	17
3.10.2	Basic Serial LED Mode	18
3.10.3	Extended LED Modes	19
3.10.4	LED Behavior	19
3.11	Wake-On-LAN and SecureOn	20
3.12	Fast Link Failure Indication	20
3.13	Forced Speed Mode Link-Up Timing	21
3.14	Testing Features	21
3.14.1	Ethernet Packet Generator	21
3.14.2	Far-End Loopback	21
3.14.3	Near-End Loopback	22
3.14.4	Connector Loopback	22

3.14.5	VeriPHY Cable Diagnostics	22
3.15	Configuration	23
3.15.1	Managed Applications	23
3.15.2	Unmanaged Applications	23
4	Registers	24
4.1	Register and Bit Conventions	24
4.2	IEEE 802.3 and Main Registers	25
4.2.1	Mode Control	26
4.2.2	Mode Status	27
4.2.3	Device Identification	27
4.2.4	Auto-Negotiation Advertisement	28
4.2.5	Link Partner Auto-Negotiation Capability	28
4.2.6	Auto-Negotiation Expansion	29
4.2.7	Transmit Auto-Negotiation Next Page	29
4.2.8	Auto-Negotiation Link Partner Next Page Receive	29
4.2.9	MMD Access Control Register	30
4.2.10	MMD Address or Data Register	30
4.2.11	100BASE-TX Status Extension	30
4.2.12	Bypass Control	31
4.2.13	Error Counter 1	31
4.2.14	Error Counter 2	31
4.2.15	Error Counter 3	32
4.2.16	Extended Control and Status	32
4.2.17	Extended PHY Control 1	33
4.2.18	Extended PHY Control 2	33
4.2.19	Interrupt Mask	34
4.2.20	Interrupt Status	35
4.2.21	Device Auxiliary Control and Status	35
4.2.22	LED Mode Select	36
4.2.23	LED Behavior	37
4.2.24	Extended Page Access	37
4.3	Extended Page 1 Registers	38
4.3.1	VeriPHY Status 1	38
4.3.2	Cu Media CRC Good Counter	38
4.3.3	Extended Mode Control	39
4.3.4	ActiPHY Control	39
4.3.5	PoE and Miscellaneous Functionality	40
4.3.6	VeriPHY Control 1	40
4.3.7	VeriPHY Control 2	41
4.3.8	VeriPHY Control 3	41
4.3.9	Ethernet Packet Generator (EPG) Control 1	42
4.3.10	Ethernet Packet Generator Control 2	42
4.4	Extended Page 2 Registers	43
4.4.1	Cu PMD Transmit Control	43
4.4.2	EEE Control	45
4.4.3	RGMIIC Control	46
4.4.4	Wake-on-LAN MAC Address [15:0]	47
4.4.5	Wake-on-LAN MAC Address [31:16]	47
4.4.6	Wake-on-LAN MAC Address [47:32]	47
4.4.7	Secure-On Password [15:0]	47
4.4.8	Secure-On Password [31:16]	48
4.4.9	Secure-On Password [47:32]	48
4.4.10	Wake-on-LAN and MAC Interface Control	48
4.4.11	Extended Interrupt Mask	49
4.4.12	Extended Interrupt Status	49
4.5	General Purpose Registers	50

4.5.1	CLKOUT Control	50
4.5.2	GPIO Control 2	50
4.5.3	Enhanced LED Control	51
4.6	Clause 45 Registers to Support Energy-Efficient Ethernet and 802.3bf	51
4.6.1	PMA/PMD Status 1	52
4.6.2	PCS Status 1	52
4.6.3	EEE Capability	52
4.6.4	EEE Wake Error Counter	52
4.6.5	EEE Advertisement	53
4.6.6	EEE Link Partner Advertisement	53
4.6.7	802.3bf Registers	53
5	Electrical Specifications	54
5.1	DC Characteristics	54
5.1.1	VDDMAC, VDDIO, and VDDMDIO (2.5 V)	54
5.1.2	VDDMAC, VDDIO, and VDDMDIO (3.3 V)	54
5.1.3	VDDMAC and VDDMDIO (1.5 V)	55
5.1.4	VDDMAC and VDDMDIO (1.8 V)	55
5.1.5	VDDMDIO (1.2 V)	55
5.1.6	XTAL1	56
5.1.7	LED	56
5.1.8	Internal Pull-Up or Pull-Down Resistors	56
5.1.9	Current Consumption	57
5.2	AC Characteristics	57
5.2.1	Reference Clock	58
5.2.2	CLKOUT	59
5.2.3	RMII_CLKOUT	59
5.2.4	Basic Serial LEDs	59
5.2.5	RMII AC Characteristics	60
5.2.6	Uncompensated RGMII	60
5.2.7	Compensated RGMII	61
5.2.8	Serial Management Interface	62
5.2.9	Reset Timing	63
5.3	Operating Conditions	63
5.4	Stress Ratings	64
6	Pin Descriptions	65
6.1	Pin Identifications	65
6.2	Pin Diagram	66
6.3	Pins by Function	66
7	Package Information	70
7.1	Package Drawing	70
7.2	Thermal Specifications	71
7.3	Moisture Sensitivity	72
8	Design Considerations	73
8.1	10BASE-T signal amplitude	73
8.2	Receive error counter only clears when NRESET applied in RMII mode	73
8.3	Anomalous PCS error indications in Energy Efficient Ethernet mode	73
8.4	10BASE-T half-duplex linkup after initial reset from power up	73
8.5	RGMII interface may not generate even count of preamble nibbles at 10 Mbps	73
8.6	Default LED0 mode is a non-applicable Gigabit value	74
8.7	Long link up times while in forced 100BASE-TX mode	74
8.8	Long link up times for 100BASE-TX parallel detection	74

9 Ordering Information 75

Figures

Figure 1	Application Diagram	2
Figure 2	Block Diagram	3
Figure 3	RGMII MAC Interface	5
Figure 4	RMII MAC Interface	5
Figure 5	Mode 1	6
Figure 6	Mode 2	7
Figure 7	Cat5 Media Interface	10
Figure 8	Low Power Idle Operation	11
Figure 9	XTAL Reference Clock	12
Figure 10	External 3.3 V Reference Clock	12
Figure 11	Inline-Powered Ethernet Switch Diagram	13
Figure 12	ActiPHY State Diagram	15
Figure 13	SMI Read Frame	16
Figure 14	SMI Write Frame	16
Figure 15	MDINT Configured as an Open-Drain (Active-Low) Pin	17
Figure 16	Wake-on-LAN Functionality	20
Figure 17	Far-End Loopback Diagram	22
Figure 18	Near-End Loopback Diagram	22
Figure 19	Connector Loopback Diagram	22
Figure 20	Register Space Diagram	24
Figure 21	Test Circuit for Clock Output Signal	58
Figure 22	Basic Serial LED Timing	60
Figure 23	Uncompensated RGMII Timing	61
Figure 24	Compensated Input RGMII Timing	62
Figure 25	Compensated Output RGMII Timing	62
Figure 26	Serial Management Interface Timing	63
Figure 27	Pin Diagram	66
Figure 28	Package Drawing	71

Tables

Table 1	Operating Modes	4
Table 2	Recommended Values for R_S ($\pm 5\%$)	4
Table 3	RMII Pin Allocation	5
Table 4	Recommended Edge Rate Settings	7
Table 5	MAC Interface Edge Rate Control	7
Table 6	Hardware Mode Strapping and PHY Addressing	8
Table 7	Managed Mode	8
Table 8	Signals A and B	9
Table 9	Signals C and D	9
Table 10	Supported MDI Pair Combinations	11
Table 11	REFCLK Frequency Selection	12
Table 12	LED Drive State	17
Table 13	LED Mode and Function Summary	17
Table 14	LED Serial Bitstream Order	18
Table 15	Extended LED Mode and Function Summary	19
Table 16	Forced Speed Mode Link-Up Timing	21
Table 17	IEEE 802.3 Registers	25
Table 18	Main Registers	25
Table 19	Mode Control, Address 0 (0x00)	26
Table 20	Mode Status, Address 1 (0x01)	27
Table 21	Identifier 1, Address 2 (0x02)	27
Table 22	Identifier 2, Address 3 (0x03)	27
Table 23	Device Auto-Negotiation Advertisement, Address 4 (0x04)	28
Table 24	Auto-Negotiation Link Partner Ability, Address 5 (0x05)	28
Table 25	Auto-Negotiation Expansion, Address 6 (0x06)	29
Table 26	Auto-Negotiation Next Page Transmit, Address 7 (0x07)	29
Table 27	Auto-Negotiation LP Next Page Receive, Address 8 (0x08)	29
Table 28	MMD EEE Access, Address 13 (0x0D)	30
Table 29	MMD Address or Data Register, Address 14 (0x0E)	30
Table 30	100BASE-TX Status Extension, Address 16 (0x10)	30
Table 31	Bypass Control, Address 18 (0x12)	31
Table 32	Extended Control and Status, Address 19 (0x13)	31
Table 33	Extended Control and Status, Address 20 (0x14)	31
Table 34	Extended Control and Status, Address 21 (0x15)	32
Table 35	Extended Control and Status, Address 22 (0x16)	32
Table 36	Extended PHY Control 1, Address 23 (0x17)	33
Table 37	Extended PHY Control 2, Address 24 (0x18)	33
Table 38	Interrupt Mask, Address 25 (0x19)	34
Table 39	Interrupt Status, Address 26 (0x1A)	35
Table 40	Auxiliary Control and Status, Address 28 (0x1C)	35
Table 41	LED Mode Select, Address 29 (0x1D)	36
Table 42	LED Behavior, Address 30 (0x1E)	37
Table 43	Extended/GPIO Register Page Access, Address 31 (0x1F)	37
Table 44	Extended Registers Page 1 Space	38
Table 45	VeriPHY Status Register 1, Address 16E1 (0x10)	38
Table 46	Cu Media CRC Good Counter, Address 18E1 (0x12)	38
Table 47	Extended Mode Control, Address 19E1 (0x13)	39
Table 48	Extended PHY Control 3, Address 20E1 (0x14)	39
Table 49	Extended PHY Control 4, Address 23E1 (0x17)	40
Table 50	VeriPHY Control Register 1, Address 24E1 (0x18)	40
Table 51	VeriPHY Control Register 2, Address 25E1 (0x19)	41
Table 52	VeriPHY Control Register 3, Address 26E1 (0x1A)	41
Table 53	VeriPHY Control Register 3 Fault Codes	41
Table 54	EPG Control Register 1, Address 29E1 (0x1D)	42
Table 55	EPG Control Register 2, Address 30E1 (0x1E)	42

Table 56	Extended Registers Page 2 Space	43
Table 57	Cu PMD Transmit Control, Address 16E2 (0x10)	43
Table 58	EEE Control, Address 17E2 (0x11)	45
Table 59	RGMII Control, Address 20E2 (0x14)	46
Table 60	Wake-on-LAN MAC Address, 21E2 (0x15)	47
Table 61	Wake-on-LAN MAC Address, 22E2 (0x16)	47
Table 62	Wake-on-LAN MAC Address, 23E2 (0x17)	47
Table 63	Secure-On Password, 24E2 (0x18)	47
Table 64	Secure-On Password, 25E2 (0x19)	48
Table 65	Secure-On Password, 26E2 (0x1A)	48
Table 66	WoL and MAC Interface Control, Address 27E2 (0x1B)	48
Table 67	Extended Interrupt Mask, Address 28E2 (0x1C)	49
Table 68	Extended Interrupt Status, Address 29E2 (0x1D)	49
Table 69	General Purpose Registers Space	50
Table 70	CLKOUT Control, Address 13G (0x0D)	50
Table 71	GPIO Control 2, Address 14G (0x0E)	50
Table 72	Enhanced LED Control, Address 25G (0x19)	51
Table 73	Clause 45 Registers Page Space	51
Table 74	PMA/PMD Status 1	52
Table 75	PCS Status 1, Address 3.1	52
Table 76	EEE Capability, Address 3.20	52
Table 77	EEE Wake Error Counter, Address 3.22	53
Table 78	EEE Advertisement, Address 7.60	53
Table 79	EEE Advertisement, Address 7.61	53
Table 80	802.3bf Registers	53
Table 81	VDDMAC, VDDIO, and VDDMDIO (2.5 V) DC Characteristics	54
Table 82	VDDMAC, VDDIO, and VDDMDIO (3.3 V) DC Characteristics	54
Table 83	VDDMAC and VDDMDIO DC Characteristics (1.5 V)	55
Table 84	VDDMAC and VDDMDIO DC Characteristics (1.8 V)	55
Table 85	VDDMDIO DC Characteristics	55
Table 86	XTAL1 DC Characteristics	56
Table 87	LED DC Characteristics	56
Table 88	Internal Pull-Up or Pull-Down Resistors (RGMII/RMII Interface)	56
Table 89	Internal Pull-Up or Pull-Down Resistors (Other I/Os)	56
Table 90	Current Consumption	57
Table 91	Current Consumption (VDDMAC)	57
Table 92	Power Consumption	57
Table 93	RefClk	58
Table 94	XTAL RefClk	58
Table 95	CLKOUT AC Characteristics	59
Table 96	RMII_CLKOUT AC Characteristics	59
Table 97	Basic Serial LEDs AC Characteristics	59
Table 98	RMII AC Characteristics	60
Table 99	Uncompensated RGMII AC Characteristics	60
Table 100	PHY Input (GTX_CLK Delay When Register 20E2.[2:0]=011'b)	61
Table 101	PHY Output (RX_CLK Delay When Register 20E2.[6:4]=100'b)	62
Table 102	Serial Management Interface AC Characteristics	62
Table 103	Reset Timing AC Characteristics	63
Table 104	Recommended Operating Conditions	63
Table 105	Stress Ratings	64
Table 106	Pin Type Symbol Definitions	65
Table 107	Thermal Resistances	72
Table 108	Ordering Information	75

1 Revision History

The revision history describes the changes that were implemented in the document. The changes are listed by revision, starting with the most current publication.

1.1 Revision 4.1

Revision 4.1 of this document was published in October 2018. The following is a summary of the changes.

- Details of LED blink or pulse-stretch behavior were corrected. For more information, see [LED Blink or Pulse-Stretch](#), page 19.
- Fast Link Failure 2™ (FLF2™) Indication is no longer supported for this device.
- Information about fast link failure indication was updated. For more information, see [Fast Link Failure Indication](#), page 20
- Forced Mode link-up times were updated. For more information, see [Table 16](#), page 21.
- Clause 45 Registers list was updated. For more information, see [Table 73](#), page 51.
- 802.3bf register names were corrected. For more information, see [Table 80](#), page 53.
- Conditions were added for the input high voltage parameters of VDDMAC and VDDMDIO DC specifications (1.5 V and 1.8 V). For more information, see [Table 83](#), page 55 and [Table 84](#), page 55.
- Extended Mode Control register bits were designated as “sticky” where applicable. For more information, see [Table 47](#), page 39.
- Bit 15 of the RGMII Control register was updated to Reserved. For more information, see [Table 59](#), page 46.
- [Table 59](#), page 46 Bits 4 and 0 of the WoL and MAC Interface Control register were designated as “sticky.” For more information, see [Table 66](#), page 48.
- REF_CLK was clarified as RMII_CLKIN in the RMII AC characteristics parameters. For more information, see [Table 98](#), page 60.
- The SMI reference description was corrected. For more information, see [Pins by Function](#), page 66.
- Additional design considerations were added. For more information, see [Design Considerations](#), page 73.

1.2 Revision 4.0

Revision 4.0 of this document was published in March 2017. This was the first publication.

2 Overview

The VSC8530-04 device is designed for space-constrained 10/100BASE-TX applications. It features integrated, line-side termination to conserve board space, lower EMI, and improve system performance. Additionally, integrated RGMII timing compensation eliminates the need for on-board delay lines.

Microsemi's EcoEthernet™ v2.0 technology supports IEEE 802.3az Energy-Efficient Ethernet (EEE) and power-saving features to reduce power based on link state and cable reach. VSC8530-04 optimizes power consumption in all link operating speeds and features a Wake-on-LAN (WoL) power management mechanism for bringing the PHY out of a low-power state using designated magic packets.

Fast link failure (FLF) indication for high availability networks identifies the onset of a link failure for 100BASE-TX links.

The following illustration shows a high-level, general view of a typical VSC8530-04 application.

Figure 1 • Application Diagram

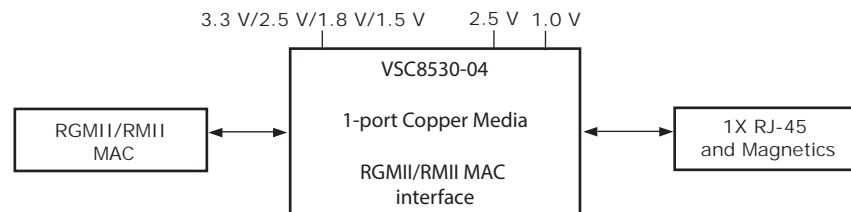

2.1 Key Features

This section lists the main features and benefits of the VSC8530-04 device.

2.1.1 Superior PHY and Interface Technology

- Integrated 10/100BASE-TX Ethernet copper transceiver with the industry's only non-TDR-based VeriPHY™ cable diagnostics algorithm
- Patented line driver with low EMI voltage mode architecture and integrated line-side termination resistors
- Wake-on-LAN using magic packets
- HP Auto-MDIX and manual MDI/MDIX support
- RGMII/RMII MAC interface
- Jumbo frame support up to 16 kilobytes with programmable synchronization FIFOs

2.1.2 Fast Link Up/Link Drop Modes

- Fast link failure indication

2.1.3 Best-in-Class Power Consumption

- EcoEthernet™ v2.0 green energy efficiency with ActiPHY™, PerfectReach™, and IEEE 802.3az Energy-Efficient Ethernet
- Fully optimized power consumption for all link speeds
- Clause 45 registers to support Energy-Efficient Ethernet

2.1.4 Key Specifications

- Compliant with IEEE 802.3 (10BASE-T, 100BASE-TX) specifications
- Supports RGMII, RMII
- Supports 1.5 V, 1.8 V, 2.5 V, and 3.3 V CMOS for RGMII versions 1.3 and 2.0 (without HSTL support), as well as RMII version 1.2
- Supports a variety of clock sources: 25 MHz Xtal, 25 MHz OSC, 50 MHz OSC, 125 MHz OSC
- Supports programmable output frequencies of 25 MHz, 50 MHz, or 125 MHz, regardless of chosen Xtal or OSC frequencies
- Supports a wide array of stand-alone hardware configuration options

- Supports all 5 bits of MDIO/MDC addressing possible for managed mode designs using pull-up/pull-down resistors
- Device supports operating temperature of -40 °C ambient to 125 °C junction
- Optionally reports if a link partner is requesting inline Power-over-Ethernet (PoE and PoE+)
- Available in 6 mm x 6 mm, 48-pin QFN package

2.2 Block Diagram

The following illustration shows the primary functional blocks of the VSC8530-04 device.

Figure 2 • Block Diagram

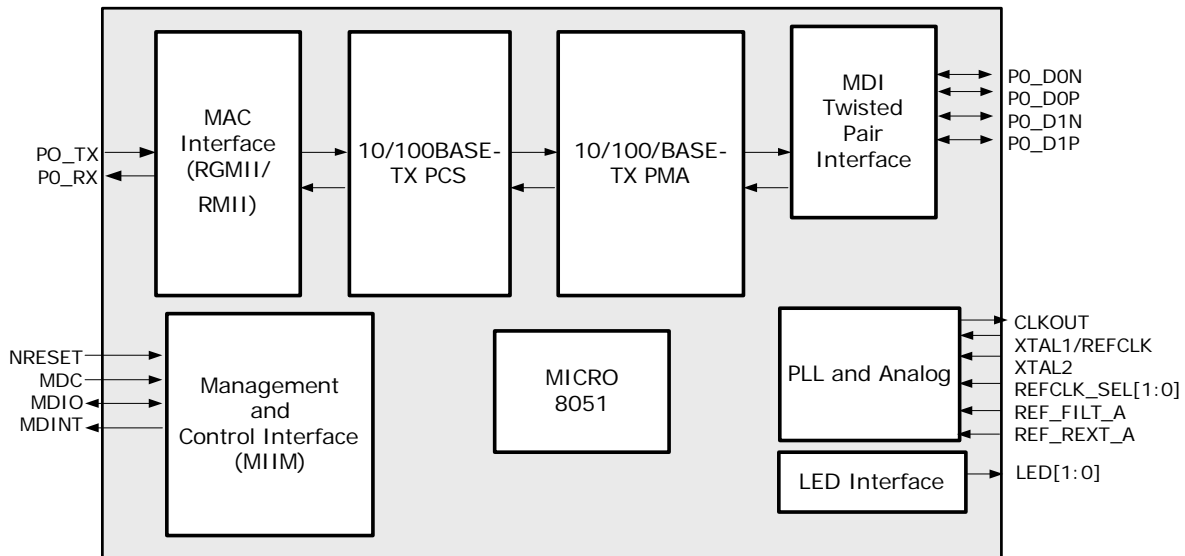

3 Functional Descriptions

This section describes the functional aspects of the VSC8530-04 device, including available configurations, operational features, and testing functionality. It also defines the device setup parameters that configure the device for a particular application.

3.1 Operating Modes

The following table lists the operating modes of the VSC8530-04 device.

Table 1 • Operating Modes

Operating Mode	Supported Media
RGMII-Cat5	10/100BASE-TX
RMII-Cat5	10/100BASE-TX

3.2 MAC Interface

The VSC8530-04 device supports RMII version 1.2 and RGMII versions 1.3 and 2.0, and MAC interfaces at 1.5 V, 1.8 V, 2.5 V, and 3.3 V operating voltages. In order to help reduce EMI, the VSC8530-04 device also includes edge rate programmability for the MAC interface signals through register 27E2.7:5.

The recommended values for R_S (as shown in [Figure 3](#), page 5, [Figure 5](#), page 6, and [Figure 6](#), page 7) are listed in the following table.

Table 2 • Recommended Values for R_S ($\pm 5\%$)

VDDMAC Value	R_S Value
1.5 V	27 Ω
1.8 V	33 Ω
2.5 V	39 Ω
3.3 V	39 Ω

Refer to the MAC datasheet for the value to use for R_T .

3.2.1 RGMII MAC Interface Mode

The VSC8530-04 device supports RGMII versions 1.3 and 2.0 (without HSTL modes). The RGMII interface supports 10 Mbps and 100 Mbps speeds, and is used as an interface to a RGMII-compatible MAC. The device is compliant with the RGMII interface specification when VDDMAC is operating at 2.5 V. While the RGMII specification only specifies operation at 2.5 V, the device can also support the RGMII interface at 1.5 V, 1.8 V, and 3.3 V.

Figure 3 • RGMII MAC Interface

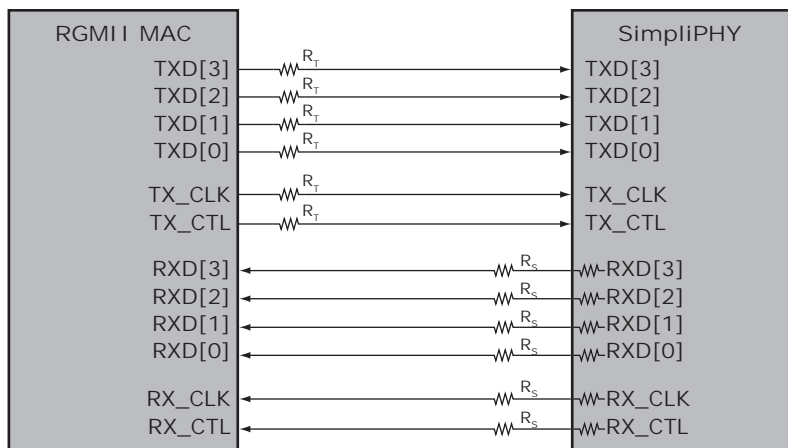

3.2.2 RMII Mode

The RMII interface supports 10 Mbps and 100 Mbps speeds, and is used as an interface to a RMII-compatible MAC. The device is compliant with the RMII interface specification when VDDMAC is operating at 3.3 V. While the RMII specification only specifies operation at 3.3 V, the device can also support the RMII interface at 1.5 V, 1.8 V, and 2.5 V.

Figure 4 • RMII MAC Interface

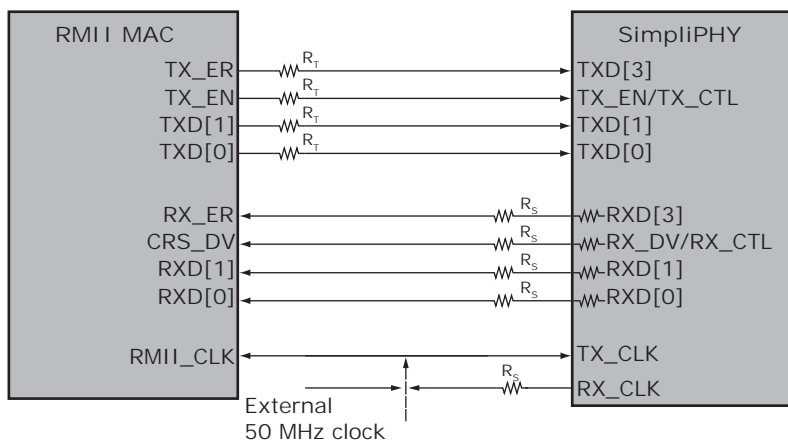

3.2.2.1 RMII Pin Allocation

The following table lists the chip pins used for RMII signaling in RMII mode.

Table 3 • RMII Pin Allocation

Chip Pin	RMII Signal
TX_CLK	RMII_CLKIN
RX_CLK	RMII_CLKOUT
TXD3	TX_ER (to support 802.3az)
TXD1	TXD1
TXD0	TXD0
TX_CTL	TX_EN
RXD1	RXD1

Table 3 • RMI Pin Allocation (continued)

Chip Pin	RMI Signal
RXD0	RXD0
RXD3	RX_ER
RX_CTL	CRS_DV

Even though the RMI specification does not call for the use of TX_ER signal, it is required in order to support Energy-Efficient Ethernet (802.3az).

3.2.2.2 RMI Clocking Overview

When the device is in RMI mode, the clock inputs to the device need to support the various modes in which RMI devices can operate. There are two basic modes of operation in RMI mode:

- Mode 1—system provides a 50 MHz clock that is used to clock the RMI interface and must be used as the chip reference clock.
- Mode 2—PHY operates from a 25 MHz or 125 MHz reference clock, and sources the 50 MHz clock used for the RMI interface.

These two modes of operation and the clocking schemes are described in the following sections.

3.2.2.2.1 Mode 1

In this mode of operation, an external source is used to provide a 50 MHz clock through the RMI_CLKIN and the XTAL1 pin. This 50 MHz clock is used as the main clock for the RMI interface, and must be used as the reference clock for the PHY connected to the XTAL1 pin. In this mode, the RMI_CLKOUT signal from the PHY is not used. The RMI_CLKOUT is enabled by default and that clock output should be disabled through register 27E2.4. The following figure illustrates RMI signal connections at the system level.

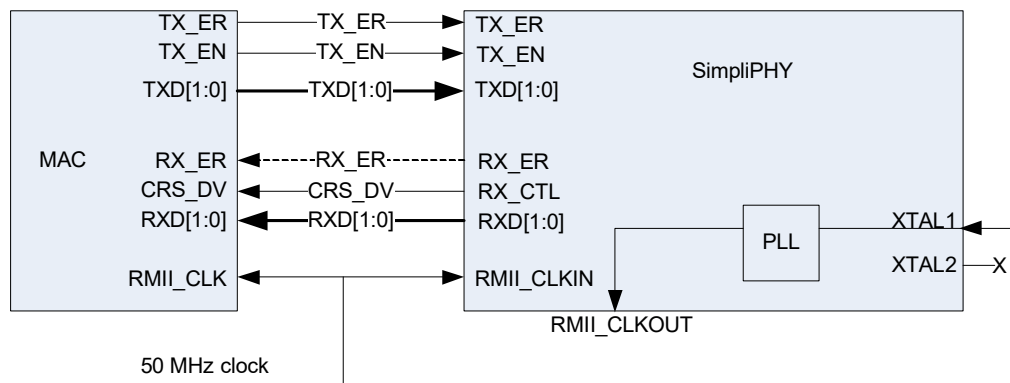
Figure 5 • Mode 1

3.2.2.2.2 Mode 2

In this mode of operation, the PHY operates from a 25 MHz crystal (XTAL1 and XTAL2) or 25 MHz/125 MHz single-ended external clock (XTAL1), and sources the 50 MHz clock required for the RMI interface. This 50 MHz clock is output from the PHY on the RMI_CLKOUT pin and then connected to the MAC and PHY RMI_CLKIN signals. In this mode, the PHY generates a 50 MHz clock for the system and that clock output is enabled. The following figure illustrates RMI signal connections at the system level.

Figure 6 • Mode 2

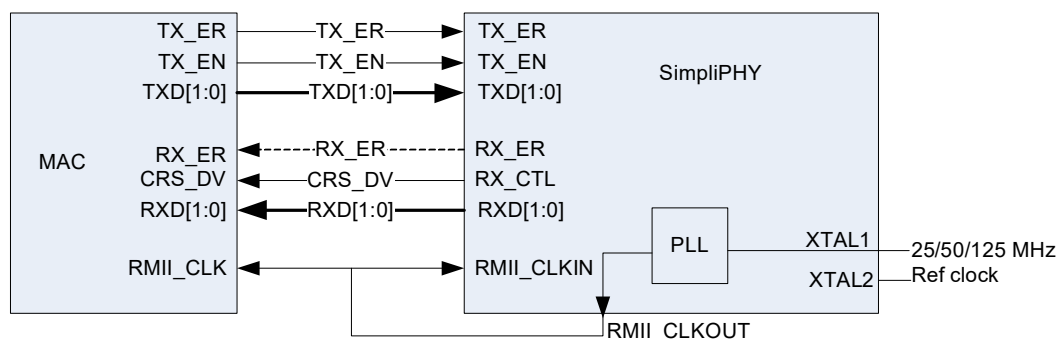

3.2.3 MAC Interface Edge Rate Control

The VSC8530-04 device includes programmable control of the rise/fall times for the MAC interface signals. The default setting will select the fastest rise/fall times. However, the fast edge rate will result in higher power consumption on the MAC interface and may result in higher EMI.

It is recommended that the user select the appropriate edge rate setting based on the VDDMAC supply voltage, as shown in the following table.

Table 4 • Recommended Edge Rate Settings

VDDMAC Voltage	Edge Rate Setting
3.3 V	100
2.5 V	100
1.8 V	111
1.5 V	111

In order to further reduce power consumption and EMI, the user may elect to choose a slower edge rate than recommended if the end application supports it.

The MAC interface signal rise/fall times can be changed by writing to register bits 27E2.7:5. The typical change in edge rate for each setting at various VDDMAC voltages is shown in the following table.

Table 5 • MAC Interface Edge Rate Control

Register Setting	Edge Rate Change (VDDMAC)			
	3.3 V	2.5 V	1.8 V	1.5 V
111 (fastest)	Default	Default	Default (recommended)	Default (recommended)
110	-2%	-3%	-5%	-6%
101	-4%	-6%	-9%	-14%
100	-7% (recommended)	-10% (recommended)	-16%	-21%
011	-10%	-14%	-23%	-29%
010	-17%	-23%	-35%	-42%
001	-29%	-37%	-52%	-58%
000 (slowest)	-53%	-63%	-76%	-77%

These values are based on measurements performed on typical silicon at nominal supply and room temperature settings.

3.3 Hardware Mode Strapping and PHY Addressing

The VSC8530-04 device provides hardware-configured modes of operation that are achieved by sampling output pins on the rising edge of reset and externally pulling the pin to a logic HIGH or LOW (based on the desired configuration). These output pins are required by the device as inputs while NRESET is asserted and the logic state of the pin is latched in the device upon de-assertion of NRESET. To ensure correct operation of the hardware strapping function, any other device connected to these pins must not actively drive a signal onto them.

The following table describes the pins used for this purpose and their respective modes.

Table 6 • Hardware Mode Strapping and PHY Addressing

Pin(s)	Operation Mode
CLKOUT	Enable/disable CLKOUT signal
RX_CLK	Managed or unmanaged mode
RXD0	Signal A
RXD1	Signal B
RXD2	Signal C
RXD3	Signal D
RX_CTL	Signal E

3.3.1 CLKOUT Signal Configuration

When the CLKOUT signal is pulled LOW and the state of that signal is latched to logic 0 on the rising edge of reset, the CLKOUT output is disabled and the device will drive a logic low level on that pin after reset de-assertion. When the CLKOUT signal is pulled HIGH externally and the state of that signal is latched to logic 1, the CLKOUT output is enabled. This behavior can also be controlled through register 13G.15.

The CLKOUT signal is frequency-locked to the reference clock signal input through XTAL1/XTAL2 pins. The frequency of CLKOUT can be programmed to the following values through register 13G.14:13:

- 25 MHz
- 50 MHz
- 125 MHz

3.3.2 Managed Mode

When RX_CLK pin is pulled LOW and the state of that signal is latched to logic 0 on the rising edge of reset, the device operates in a managed mode. In managed mode, the remaining 5 signals (A–E) are used to set the PHY address, allowing up to 32 devices to reside on the shared MDIO bus. In this mode, the device can be configured using register access and no additional hardware configurability is provided. The following table lists the assigned PHY address values in managed mode.

Table 7 • Managed Mode

Signal	PHY Address Values
Signal A	PHY address bit 0
Signal B	PHY address bit 1
Signal C	PHY address bit 2
Signal D	PHY address bit 3
Signal E	PHY address bit 4

3.3.3 Unmanaged Mode

When RX_CLK is pulled HIGH externally and the state of that signal is latched to logic 1 on the rising edge of reset, the device operates in an unmanaged mode. In unmanaged mode, the PHY address of the device is fixed to 5'b00000. The signals A–E are used to set default chip configurations, as described in the following sections.

Note: Operating the device in unmanaged mode requires that the NRESET pin is asserted twice during device configuration (for more information, see [Configuration](#), page 23).

Note: The default values for the following registers depend on the chosen hardware strapping options.

- 0.13, 0.6—Forced speed selection
- 0.12—Enable autonegotiation
- 0.8—Duplex
- 23.12:11—MAC interface selection
- 19E1.3:2—Force MDI crossover
- 20E2.6:4—RX_CLK delay
- 20E2.2:0—TX_CLK delay

Additionally, the following registers are set to 1 by default in unmanaged mode.

- 28.6—ActiPHY enable

3.3.3.1 Signals A and B

Signals A and B are used to set the RGMII RX_CLK and TX_CLK delay settings (as defined in register 20E2), as per the following table.

Table 8 • Signals A and B

Signals A, B	RX_CLK and TX_CLK Delay Setting
0, 0	000 - 0.2 ns
0, 1	010 - 1.1 ns
1, 0	100 - 2.0 ns
1, 1	110 - 2.6 ns

3.3.3.2 Signals C and D

Signals C and D are used to select the link advertisement settings, as defined in the following table.

Table 9 • Signals C and D

Signals C, D	Link Advertisement
0, 0/1	Default mode of operation, 10/100/ FDX/HDX, autoneg ON
1, 0	100BTX, HDX forced mode, autoneg OFF
1, 1	10BT, HDX forced mode, autoneg OFF

3.3.3.3 Signal E

Signal E is used to select between RMII and RGMII MAC interface modes. When the state of Signal E is latched to logic 0 on the rising edge of reset, the device operates in RGMII mode. When the state of Signal E is latched to logic 1 on the rising edge of reset, the device operates in RMII mode.

Note: RMII only supports 10/100 Mbps speeds. When RMII mode is selected, the link advertisement selection must also be changed to either 01, 10, or 11 settings, as defined in [Table 9](#), page 9.

Note: Correct configuration of the device is an end user responsibility, and no attempt is made in the device to disallow incorrect configurations.

Additionally, in unmanaged mode, the following settings are changed from their default values:

- Enable ActiPHY (register 28.6 set to 1)

3.4 Cat5 Twisted Pair Media Interface

The twisted pair interface is compliant with IEEE 802.3-2008 and the IEEE 802.3az-2010 standard for Energy-Efficient Ethernet.

3.4.1 Voltage Mode Line Driver

The VSC8530-04 device uses a patented voltage mode line driver that allows it to fully integrate the series termination resistors that are required to connect the PHY's Cat5 interface to an external 1:1 transformer. The interface does not require the user to place an external voltage on the center tap of the magnetic. The following figure illustrates the connections.

Figure 7 • Cat5 Media Interface

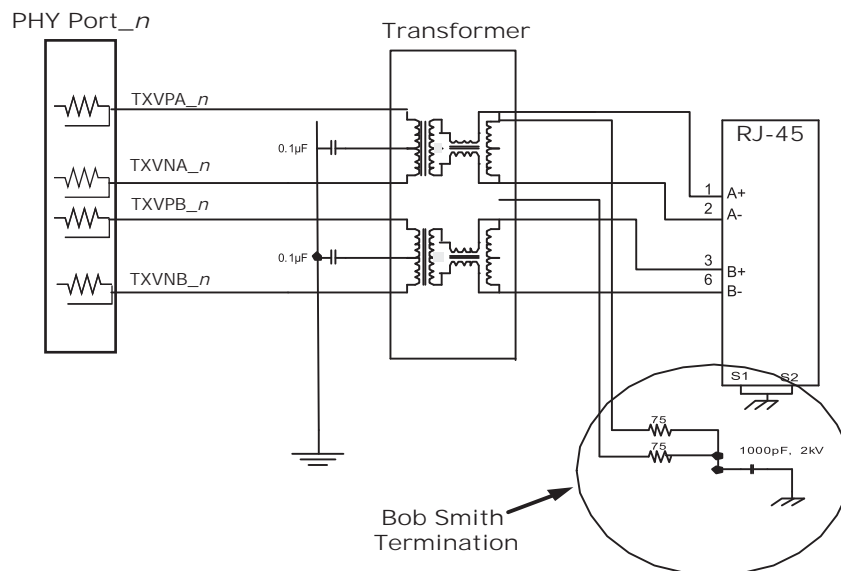

3.4.2 Cat5 Auto-Negotiation and Parallel Detection

The VSC8530-04 device supports twisted pair auto-negotiation, as defined by IEEE 802.3-2008 Clause 28 and IEEE 802.3az-2010. The auto-negotiation process evaluates the advertised capabilities of the local PHY and its link partner to determine the best possible operating mode. In particular, auto-negotiation can determine speed and duplex configuration. Auto-negotiation also enables a connected MAC to communicate with its link partner MAC through the VSC8530-04 device using optional next pages to set attributes that may not otherwise be defined by the IEEE standard.

If the Category 5 (Cat5) link partner does not support auto-negotiation, the VSC8530-04 device automatically uses parallel detection to select the appropriate link speed.

Auto-negotiation is disabled by clearing register 0, bit 12. When auto-negotiation is disabled, the state of register bits 0.6, 0.13, and 0.8 determine the device operating speed and duplex mode.

3.4.3 Automatic Crossover and Polarity Detection

For trouble-free configuration and management of Ethernet links, the VSC8530-04 device includes a robust automatic crossover detection feature for all speeds on the twisted pair interface. Known as HP Auto-MDIX, the function is fully compliant with Clause 40 of IEEE 802.3-2008.

Additionally, the device detects and corrects polarity errors on all MDI pairs—a useful capability that exceeds the requirements of the standard.

Both HP Auto-MDIX detection and polarity correction are enabled in the device by default. Default settings can be changed using device register bits 18.5:4. Status bits for each of these functions are located in register 28.

Note: The VSC8530-04 device can be configured to perform HP Auto-MDIX, even when auto-negotiation is disabled and the link is forced into 10/100 speeds. To enable this feature, set register 18.7 to 0. To use the feature, also set register 0.12 to 0.

The HP Auto-MDIX algorithm successfully detects, corrects, and operates with any of the MDI wiring pair combinations listed in the following table, which shows that twisted pair A is connected to the RJ45 connector 1, 2 in normal MDI mode.

Table 10 • Supported MDI Pair Combinations

RJ45 Connections		
1, 2	3, 6	Mode
A	B	Normal MDI
B	A	Normal MDI-X

3.4.4 Manual MDI/MDIX Setting

As an alternative to HP Auto-MDIX detection, the PHY can be forced to be MDI or MDI-X using register 19E1, bits 3:2. Setting these bits to 10 forces MDI and setting 11 forces MDI-X. Leaving the bits 00 enables the HP Auto-MDIX setting to be based on register 18, bits 7 and 5.

3.4.5 Energy-Efficient Ethernet

The VSC8530-04 device supports the IEEE 802.3az-2010 Energy-Efficient Ethernet standard to provide a method for reducing power consumption on an Ethernet link during times of low utilization. It uses low power idles (LPI) to achieve this objective.

Figure 8 • Low Power Idle Operation

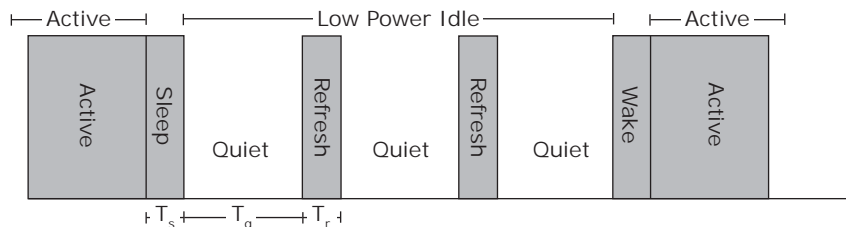

Using LPI, the usage model for the link is to transmit data as fast as possible and then return to a low power idle state. Energy is saved on the link by cycling between active and low power idle states. During LPI, power is reduced by turning off unused circuits and using this method, energy use scales with bandwidth utilization. The VSC8530-04 device uses LPI to optimize power dissipation in 100BASE-TX mode.

In addition, the IEEE 802.3az-2010 standard defines a 10BASE-Te mode that reduces transmit signal amplitude from 5 V peak-to-peak to approximately 3.3 V peak-to-peak. This mode reduces power consumption in 10 Mbps link speed and fully interoperates with legacy 10BASE-T-compliant PHYs over 100 m Cat5 cable or better.

To configure the VSC8530-04 device in 10BASE-Te mode, set register 17E2.15 to 1 for each port. Additional energy-efficient Ethernet features are controlled through Clause 45 registers. For more information, see [Clause 45 Registers to Support Energy-Efficient Ethernet and 802.3bf](#), page 51.

3.5 Reference Clock

The VSC8530-04 device supports multiple reference clock input options to allow maximum system level flexibility. There are two REFCLK_SEL signals available to allow an end user to select between the various options. The following table shows the functionality and associated reference clock frequency.

Table 11 • REFCLK Frequency Selection

REFCLK_SEL [1:0]	Reference Clock Mode
00	25 MHz, on-chip oscillator ON (XTAL1/2 pins)
01	25 MHz, on-chip oscillator OFF (XTAL1 pin)
10	50 MHz, on-chip oscillator OFF (XTAL1 pin)
11	125 MHz, on-chip oscillator OFF (XTAL1 pin)

The following figure shows a reference tank circuit for a fundamental mode crystal.

Note: For best performance, traces on PCB should be of similar length and Kelvin-connected to ground.

Figure 9 • XTAL Reference Clock

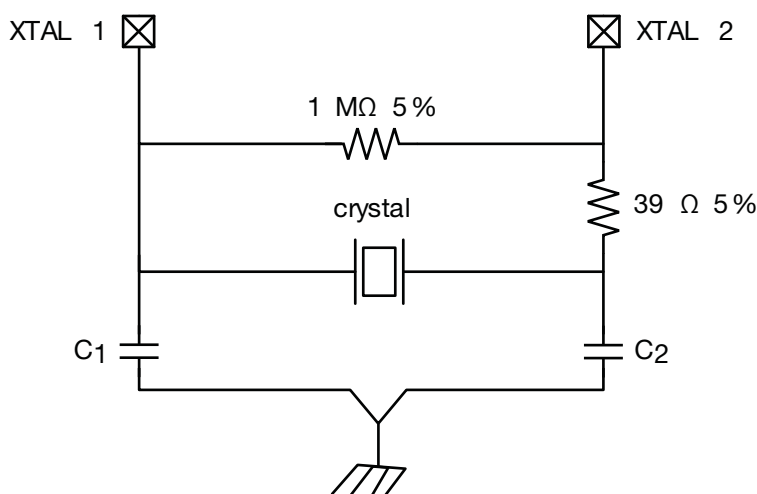

with REFCLK_SEL [1:0] = 00

Note: Routing capacitance less than 1 pF from each XTAL pin to crystal device.

The following figure shows an external 3.3 V reference clock.

Figure 10 • External 3.3 V Reference Clock

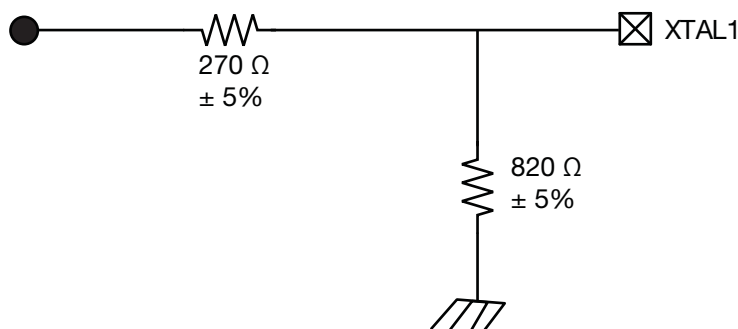

Note: Reference clock source less than $\lambda/10$ from XTAL1.

Note: No voltage scaling is required for a 2.5 V external reference.

3.6 Ethernet Inline-Powered Devices

The VSC8530-04 device can detect legacy inline-powered devices in Ethernet network applications. Inline-powered detection capability is useful in systems that enable IP phones and other devices (such as wireless access points) to receive power directly from their Ethernet cable, similar to office digital phones receiving power from a private branch exchange (PBX) office switch over telephone cabling. This type of setup eliminates the need for an external power supply and enables the inline-powered device to remain active during a power outage, assuming that the Ethernet switch is connected to an uninterrupted power supply, battery, back-up power generator, or other uninterruptible power source.

For more information about legacy inline-powered device detection, visit the Cisco website at www.cisco.com. The following illustration shows an example of an inline-powered Ethernet switch application.

Figure 11 • Inline-Powered Ethernet Switch Diagram

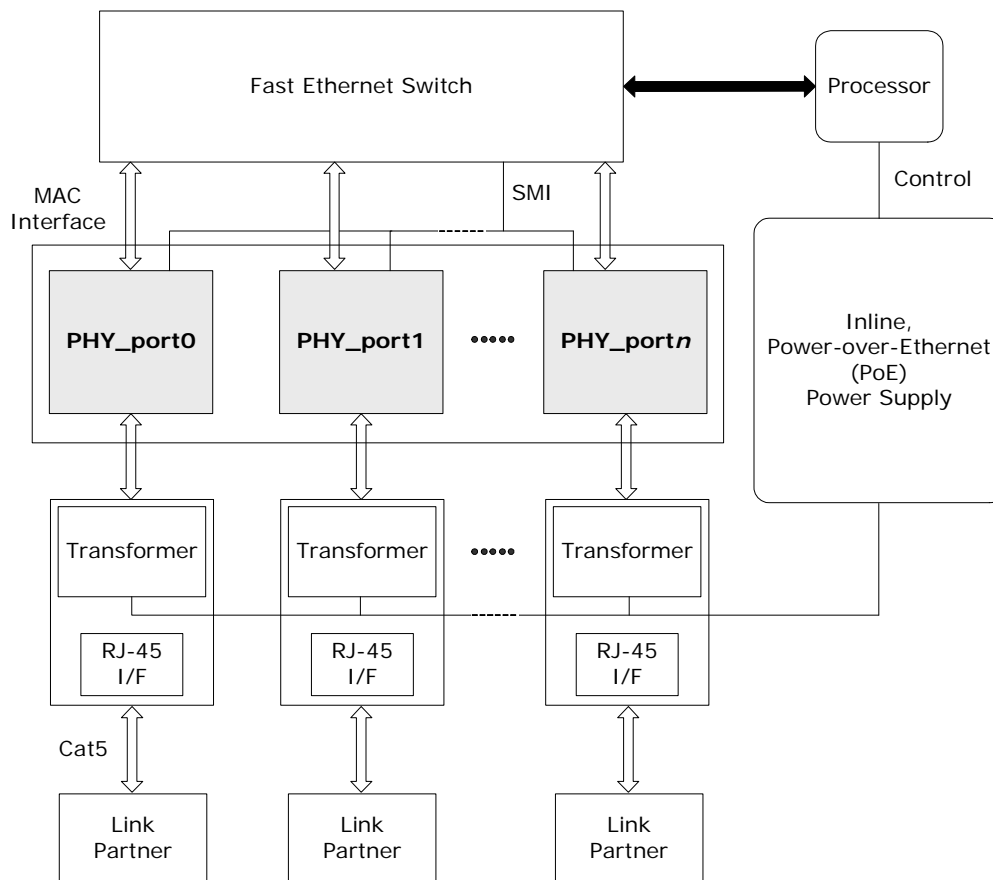

The following procedure describes the steps that an Ethernet switch must perform to process inline-power requests made by a link partner that is, in turn, capable of receiving inline-power:

1. Enable the inline-powered device detection mode on each VSC8530-04 PHY using its serial management interface. Set register bit 23E1.10 to 1.
2. Ensure that the auto-negotiation enable bit (register 0.12) is also set to 1. In the application, the device sends a special fast link pulse signal to the link partner. Reading register bit 23E1.9:8 returns 00 during the search for devices that require Power-over-Ethernet (PoE).
3. The VSC8530-04 PHY monitors its inputs for the fast link pulse signal looped back by the link partner. A link partner capable of receiving PoE loops back the fast link pulses when the link partner is in a powered down state. This is reported when register bit 23E1.9:8 reads back 01. It can also be verified as an inline-power detection interrupt by reading register bit 26.9, which should be a 1, and which is subsequently cleared and the interrupt de-asserted after the read. When a link partner

- device does not loop back the fast link pulse after a specific time, register bit 23E1.9:8 automatically resets to 10.
4. If the VSC8530-04 PHY reports that the link partner requires PoE, the Ethernet switch must enable inline-power on this port, independent of the PHY.
 5. The PHY automatically disables inline-powered device detection when the register bits 23E1.9:8 automatically reset to 10, and then automatically changes to its normal auto-negotiation process. A link is then autonegotiated and established when the link status bit is set (register bit 1.2 is set to 1).
 6. In the event of a link failure (indicated when register bit 1.2 reads 0), it is recommended that the inline-power be disabled to the inline-powered device independent of the PHY. The VSC8530-04 PHY disables its normal auto-negotiation process and re-enables its inline-powered device detection mode.

3.7 IEEE 802.3af Power-over-Ethernet Support

The VSC8530-04 device is compatible with designs intended for use in systems that supply power to data terminal equipment (DTE) by means of the MDI or twisted pair cable, as described in IEEE 802.3af Clause 33.

3.8 ActiPHY Power Management

In addition to the IEEE-specified power down control bit (device register bit 0.11), the VSC8530-04 device also includes an ActiPHY power management mode for each PHY. This mode enables support for power-sensitive applications. It utilizes a signal-detect function that monitors the media interface for the presence of a link to determine when to automatically power down the PHY. The PHY wakes up at a programmable interval and attempts to wake up the link partner PHY by sending a burst of fast link pulse over copper media.

The ActiPHY power management mode is enabled on a per-port basis during normal operation at any time by setting register bit 28.6 to 1.

The following operating states are possible when ActiPHY mode is enabled:

- Low power state
- Link partner wake-up state
- Normal operating state (link-up state)

The VSC8530-04 device switches between the low power state and link partner wake-up state at a programmable rate (the default is two seconds) until signal energy has been detected on the media interface pins. When signal energy is detected, the PHY enters the normal operating state. If the PHY is in its normal operating state and the link fails, the PHY returns to the low power state after the expiration of the link status time-out timer. After reset, the PHY enters the low power state.

When auto-negotiation is enabled in the PHY, the ActiPHY state machine operates as described.

When auto-negotiation is disabled and the link is forced to use 10BASE-T or 100BASE-TX modes while the PHY is in its low power state, the PHY continues to transition between the low power and link partner wake-up states until signal energy is detected on the media pins. At that time, the PHY transitions to the normal operating state and stays in that state even when the link is dropped. When auto-negotiation is disabled while the PHY is in the normal operation state, the PHY stays in that state when the link is dropped and does not transition back to the low power state.

The following illustration shows the relationship between ActiPHY states and timers.

Figure 12 • ActiPHY State Diagram

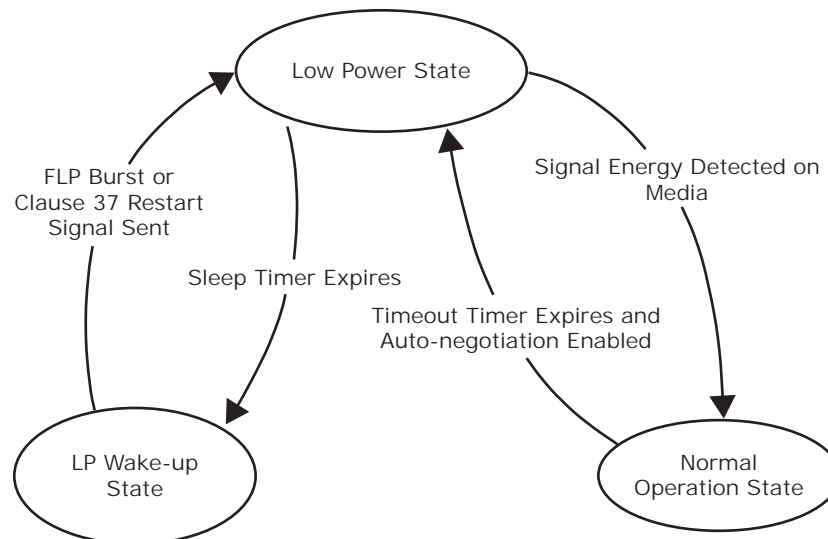

3.8.1 Low Power State

In the low power state, all major digital blocks are powered down. However, the SMI interface (MDC, MDIO, and MDINT) functionality is provided.

In this state, the PHY monitors the media interface pins for signal energy. The PHY comes out of low power state and transitions to the normal operating state when signal energy is detected on the media. This happens when the PHY is connected to an auto-negotiation-capable link partner or another PHY in enhanced ActiPHY link partner wake-up state

In the absence of signal energy on the media pins, the PHY periodically transitions from low-power state to link partner wake-up state, based on the programmable sleep timer (register bits 20E1.14:13). The actual sleep time duration is randomized from –80 ms to 60 ms to avoid two linked PHYs in ActiPHY mode entering a lock-up state during operation.

3.8.2 Link Partner Wake-Up State

In the link partner wake-up state, the PHY attempts to wake up the link partner. Up to three complete fast link pulse bursts are sent on alternating pairs A and B of the Cat5 media for a duration based on the wake-up timer, which is set using register bits 20E1.12:11.

In this state, SMI interface (MDC, MDIO, and MDINT) functionality is provided.

After sending signal energy on the relevant media, the PHY returns to the low power state.

3.8.3 Normal Operating State

In the normal operating state, the PHY establishes a link with a link partner. When the media is unplugged or the link partner is powered down, the PHY waits for the duration of the programmable link status time-out timer, which is set using register bit 28.7 and bit 28.2. It then enters the low power state.

3.9 Serial Management Interface

The VSC8530-04 device includes an IEEE 802.3-compliant Serial Management Interface (SMI) that is affected by use of its MDC and MDIO pins. The SMI provides access to device control and status registers. The register set that controls the SMI consists of 32 16-bit registers, including all required IEEE-specified registers. Additional pages of registers are accessible using device register 31.

Energy-efficient Ethernet control registers are available through the SMI using Clause 45 registers and Clause 22 register access in registers 13 through 14.

The SMI is a synchronous serial interface with input data to the VSC8530-04 device on the MDIO pin that is clocked on the rising edge of the MDC pin. The output data is sent on the MDIO pin on the rising edge

of the MDC signal. The interface can be clocked at a rate from 0 MHz to 12.5 MHz, depending on the total load on MDIO. An external 2 k Ω pull-up resistor is required on the MDIO pin.

3.9.1 SMI Frames

Data is transferred over the SMI using 32-bit frames with an optional, arbitrary-length preamble. Before the first frame can be sent, at least two clock pulses on MDC must be provided with the MDIO signal at logic one to initialize the SMI state machine. The following illustrations show the SMI frame format for read and write operations.

Figure 13 • SMI Read Frame

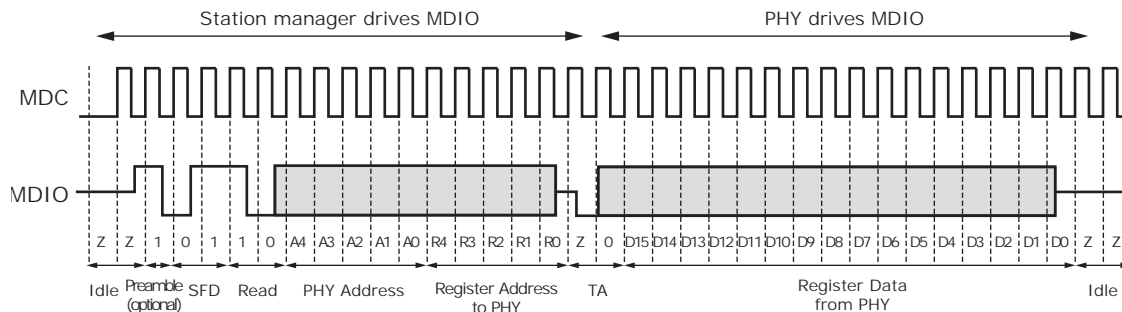
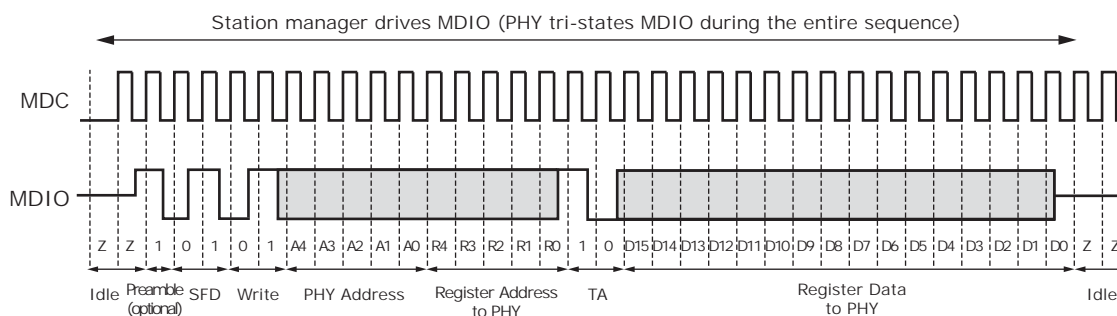

Figure 14 • SMI Write Frame



The following list defines the terms used in the SMI read and write timing diagrams.

- **Idle**—During idle, the MDIO node goes to a high-impedance state. This allows an external pull-up resistor to pull the MDIO node up to a logical 1 state. Because the idle mode does not contain any transitions on MDIO, the number of bits is undefined during idle.
- **Preamble**—By default, preambles are not expected or required. The preamble is a string of ones. If it exists, the preamble must be at least 1 bit; otherwise, it can be of an arbitrary length.
- **Start of Frame Delimiter (SFD)**—A pattern of 01 indicates the start of frame. If the pattern is not 01, all following bits are ignored until the next preamble pattern is detected.
- **Read or Write Opcode**—A pattern of 10 indicates a read. A 01 pattern indicates a write. If the bits are not either 01 or 10, all following bits are ignored until the next preamble pattern is detected.
- **PHY Address**—The particular VSC8530-04 device responds to a message frame only when the received PHY address matches its physical address. The physical address is 5 bits long (4:0).
- **Register Address**—The next five bits are the register address.
- **Turnaround**—The two bits used to avoid signal contention when a read operation is performed on the MDIO are called the turnaround (TA) bits. During read operations, the VSC8530-04 device drives the second TA bit, a logical 0.
- **Data**—The 16-bits read from or written to the device are considered the data or data stream. When data is read from a PHY, it is valid at the output from one rising edge of MDC to the next rising edge of MDC. When data is written to the PHY, it must be valid around the rising edge of MDC.
- **Idle**—The sequence is repeated.

3.9.2 SMI Interrupt

The SMI includes an interrupt signal, MDINT, for signaling the station manager when certain events occur in the VSC8530-04 device.

When a PHY generates an interrupt, the MDINT pin is asserted by driving low if the interrupt pin enable bit (register 25.15) is set. The MDINT pin is configured for open-drain (active-low) operation. Tie the pin to a pull-up resistor to VDDMDIO. The following illustration shows the configuration.

Figure 15 • MDINT Configured as an Open-Drain (Active-Low) Pin

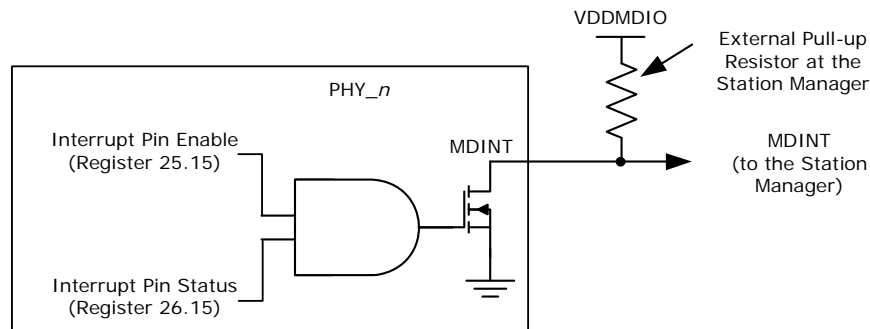

3.10 LED Interface

The LED interface supports direct drive and basic serial LED mode configuration. The polarity of the LED outputs is programmable and can be changed using register 17E2, bits 13:10. The default polarity is active low.

Direct drive mode provides two LED signals, LED0 and LED1. The mode and function of each LED signal can be configured independently.

In basic serial LED mode, all signals that can be displayed on LEDs are sent as LED_Data and LED_CLK for external processing.

The following table shows the bit 9 settings for register 14G that are used to control the LED behavior for all the LEDs in the VSC8530-04 device.

Table 12 • LED Drive State

Setting	Active	Not Active
14G.9 = 1 (default)	Ground	Tristate
14G.9 = 0 (alternate setting)	Ground	V _{DD}

3.10.1 LED Modes

Each LED pin can be configured to display different status information that can be selected by setting the LED mode in register 29. The default LED state is active low and can be changed by modifying the value in register 17E2, bits 13:10. The blink/pulse stretch is dependent on the LED behavior setting in register 30.

The following table provides a summary of the LED modes and functions. The modes listed are equivalent to the setting used in register 29 to configure each LED pin.

Table 13 • LED Mode and Function Summary

Mode	Function Name	LED State and Description
0	Link/Activity	1: No link in any speed on any media interface. 0: Valid link at any speed on any media interface. Blink or pulse-stretch = Valid link at any speed on any media interface with activity present.
1	Reserved	Reserved.

Table 13 • LED Mode and Function Summary (continued)

Mode	Function Name	LED State and Description
2	Link100/Activity	1: No link in 100BASE-TX. 0: Valid 100BASE-TX. Blink or pulse-stretch = Valid 100BASE-TX link with activity present.
3	Link10/Activity	1: No link in 10BASE-T. 0: Valid 10BASE-T link. Blink or pulse-stretch = Valid 10BASE-T link with activity present.
4	Reserved	Reserved.
5	Reserved	Reserved.
6	Link10/100/Activity	1: No link in 10BASE-T or 100BASE-TX. 0: Valid 10BASE-T or 100BASE-TX link. Blink or pulse-stretch = Valid 10BASE-T or 100BASE-TX link with activity present.
7	Reserved	Reserved.
8	Duplex/Collision	1: Link established in half-duplex mode, or no link established. 0: Link established in full-duplex mode. Blink or pulse-stretch = Link established in half-duplex mode but collisions are present.
9	Collision	1: No collision detected. Blink or pulse-stretch = Collision detected.
10	Activity	1: No activity present. Blink or pulse-stretch = Activity present (becomes TX activity present when register bit 30.14 is set to 1).
11	Reserved	Reserved.
12	Autonegotiation Fault	1: No auto-negotiation fault present. 0: Auto-negotiation fault occurred.
13	Serial Mode	Serial stream. See Basic Serial LED Mode , page 18. Only relevant on PHY port 0. Reserved in others.
14	Force LED Off	1: De-asserts the LED ¹ .
15	Force LED On	0: Asserts the LED ¹ .

1. Setting this mode suppresses LED blinking after reset.

3.10.2 Basic Serial LED Mode

The VSC8530-04 device can be configured so that access to all its LED signals is available through two pins. This option is enabled by setting LED0 to serial LED mode in register 29, bits 3:0 to 0xD. When serial LED mode is enabled, the LED0 pin becomes the serial data pin, and the LED1 pin becomes the serial clock pin. The serial LED mode clocks the LED status bits on the rising edge of the serial clock.

The LED behavior settings can also be used in serial LED mode. The LED combine and LED blink or pulse-stretch setting of LED0 is used to control the behavior of each bit of the serial LED stream. To configure LED behavior, set device register 30.

The following table shows the serial output bitstream of each LED signal.

Table 14 • LED Serial Bitstream Order

Output	
Link/activity	1
Reserved	2

Table 14 • LED Serial Bitstream Order (continued)

Output	
Link100/activity	3
Link10/activity	4
Reserved	5
Duplex/collision	6
Collision	7
Activity	8
Reserved	9
Tx activity	10
Rx activity	11
Autonegotiation fault	12

3.10.3 Extended LED Modes

In addition to the LED modes in register 29, there are also additional LED modes that are enabled on the LED pin whenever the corresponding register 19E1, bits 13 to 12 are set to 1. Each of these bits enable an extended mode shown in the following table. For example, LED0 = mode 22 means that register 19E1 bit 12 = 1 and register 29 bits 3 to 0 = 0110.

The following table provides a summary of the extended LED modes and functions.

Table 15 • Extended LED Mode and Function Summary

Mode	Function Name	LED State and Description
16-19	Reserved	Reserved.
20	Force LED Off	1: De-asserts the LED.
21	Force LED On	0: Asserts the LED. LED pulsing is disabled in this mode.
22	Fast Link Fail	Enable fast link fail on the LED pin.
23	WoL interrupt	Enable WoL interrupt indication on the LED pin.

3.10.4 LED Behavior

Several LED behaviors can be programmed into the VSC8530-04 device. Use the settings in register 30 and 19E1 to program LED behavior, as described in the following sections.

3.10.4.1 LED Combine

Enables an LED to display the status for a combination of primary and secondary modes. This can be enabled or disabled for each LED pin. For example, a copper link running in 100BASE-TX mode and activity present can be displayed with one LED by configuring an LED pin to Link100/Activity mode. The LED asserts when linked to a 100BASE-TX partner and also blinks or performs pulse-stretch when activity is either transmitted by the PHY or received by the link partner. When disabled, the combine feature only provides the status of the selected primary function. In this example, only Link100 asserts the LED, and the secondary mode, Activity, does not display when the combine feature is disabled.

3.10.4.2 LED Blink or Pulse-Stretch

This behavior is available for the LED mode 9 (collision) and LED mode 10 (activity) indications only, and can be uniquely configured for each LED pin. For more information, see [Table 13](#), page 17. Activity and collision events can occur randomly and intermittently throughout the link-up period. Blink is a 50% duty cycle oscillation of asserting and de-asserting an LED pin. Pulse-stretch ensures that an LED is asserted and de-asserted for a specific period of time when activity is either present or not present. These rates can also be configured using a register setting.

3.10.4.3 Rate of LED Blink or Pulse-Stretch

This behavior controls the LED blink rate or pulse-stretch length when blink/pulse-stretch is enabled on a LED pin. The blink rate, which alternates between a high and low voltage level at a 50% duty cycle, can be set to 2.5 Hz, 5 Hz, 10 Hz, or 20 Hz. For pulse-stretch, the rate can be set to 50 ms, 100 ms, 200 ms, or 400 ms.

3.10.4.4 LED Pulsing Enable

To provide additional power savings, the LEDs (when asserted) can be pulsed at 5 kHz programmable duty cycle. The pulsing enable is controlled through register 30, bit 12 and the duty cycle through register 25G, bits 15:8.

3.10.4.5 LED Blink After Reset

[Configuration](#), page 23 The LEDs will blink for one second after a software reset is applied. This feature can be enabled by setting register 19E1, bit 11 = 1.

3.10.4.6 Pulse Programmable Control

These bits add the ability to width and frequency of LED pulses. This feature facilitates power reduction options.

3.10.4.7 Fast Link Failure

For more information about this feature, see [Fast Link Failure Indication](#), page 20.

3.11 Wake-On-LAN and SecureOn

The VSC8530-04 device supports Wake-on-LAN, an Ethernet networking standard to awaken hosts by using a “magic packet” that is decoded to ascertain the source, and then assert an interrupt pin or a LED. The VSC8530-04 device also supports SecureOn to secure Wake-on-LAN against unauthorized access. The following illustration shows an overview of the Wake-on-LAN functionality.

Figure 16 • Wake-on-LAN Functionality

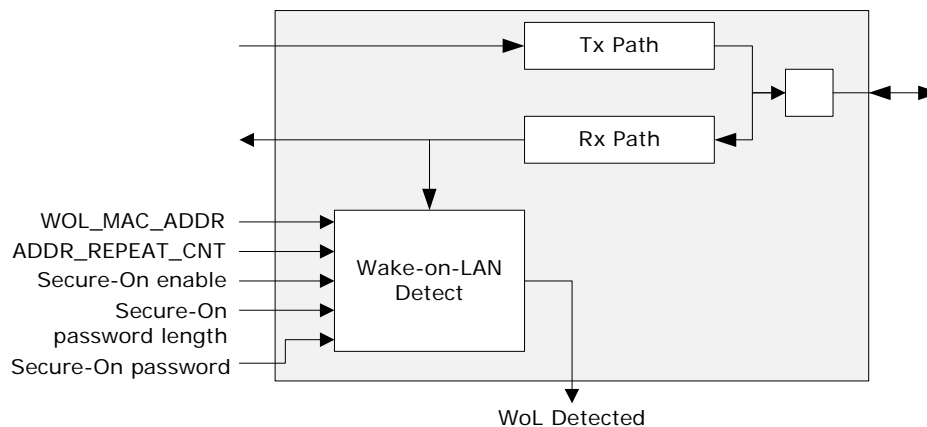

Wake-on-LAN detection is available in 10BASE-T and 100BASE-TX modes. It is enabled by setting the interrupt mask register (25.6) and its status is read in the interrupt status register (26.6). Wake-on-LAN and SecureOn are configured using register 27E2. The MAC address is saved in its local register space (21E2, 22E2, and 23E2).

3.12 Fast Link Failure Indication

For 100BASE-TX links, the link failure is based on a circuit that analyzes the integrity of the link and will assert at the indication of failure (< 3 ms, worst case).

Fast link failure is supported through the MDINT (active low) pin only in 100BASE-TX mode.

Note: A system can later confirm the fast link down indication for system management purposes by actively polling the link status bit to determine if a link has failed.

Note: Fast Link Failure Indication should not be used when EEE is enabled on a link.

3.13 Forced Speed Mode Link-Up Timing

The following table specifies the time the device will take to establish a link when operating in a forced speed mode.

Table 16 • Forced Speed Mode Link-Up Timing

Forced Mode	Minimum	Maximum	Units
100Base-TX, HP Auto-MDIX Disabled	43	240	ms
100Base-TX, HP Auto-MDIX Enabled	43	4000	ms

In 100Base-TX mode, HP Auto-MDIX can be disabled by setting register 18 bit 7.

Link-up times are given for previously-configured PHYs on each side of the link— that is, the times do not include configuration time prior to attempting link-up. Both the device and link partner must be configured in forced speed mode to achieve the listed link-up times.

3.14 Testing Features

The VSC8530-04 device includes several testing features designed to facilitate performing system-level debugging and in-system production testing. This section describes the available features.

3.14.1 Ethernet Packet Generator

The Ethernet Packet Generator (EPG) can be used at each of the 10/100BASE-TX speed settings for copper Cat5 media to isolate problems between the MAC and the VSC8530-04 device, or between a locally connected PHY and its remote link partner. Enabling the EPG feature disables all MAC interface transmit pins and selects the EPG as the source for all data transmitted onto the twisted pair interface.

Note: The EPG is intended for use with laboratory or in-system testing equipment only. Do not use the EPG testing feature when the VSC8530-04 device is connected to a live network.

To enable the EPG feature, set the device register bit 29E1.15 to 1.

When the EPG is enabled, packet loss occurs during transmission of packets from the MAC to the PHY. However, the PHY receive output pins to the MAC are still active when the EPG is enabled. When it is necessary to disable the MAC receive pins as well, set the register bit 0.10 to 1.

When the device register bit 29E1.14 is set to 1, the PHY begins transmitting Ethernet packets based on the settings in registers 29E1 and 30E1. These registers set:

- Source and destination addresses for each packet
- Packet size
- Interpacket gap
- FCS state
- Transmit duration
- Payload pattern

When register bit 29E1.13 is set to 0, register bit 29E1.14 is cleared automatically after 30,000,000 packets are transmitted.

3.14.2 Far-End Loopback

The far-end loopback testing feature is enabled by setting register bit 23.3 to 1. When enabled, it forces incoming data from a link partner on the media interface into the MAC interface of the PHY where it is retransmitted back to the link partner on the media interface, as shown in the following illustration. In addition, the incoming data also appears on the receive data pins of the MAC interface. Data present on the transmit data pins of the MAC interface is ignored when using this testing feature.

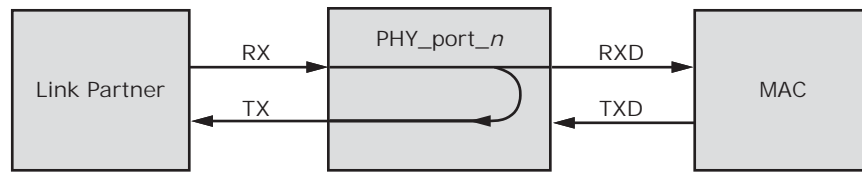
Figure 17 • Far-End Loopback Diagram

3.14.3 Near-End Loopback

When the near-end loopback testing feature is enabled, transmitted data (TXD) is looped back in the PCS block onto the receive data signals (RXD), as shown in the following illustration. When using this testing feature, no data is transmitted over the network. To enable near-end loopback, set the device register bit 0.14 to 1.

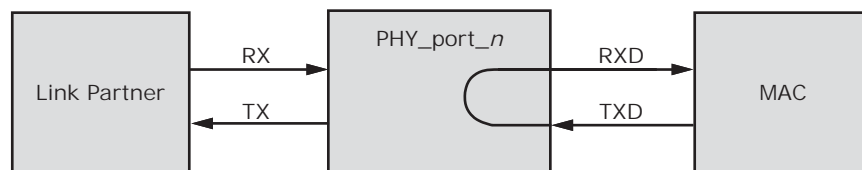
Figure 18 • Near-End Loopback Diagram

3.14.4 Connector Loopback

The connector loopback testing feature allows the twisted pair interface to be looped back externally. When using this feature, the PHY must be connected to a loopback connector or a loopback cable. Connect pair A to pair B, as shown in the following illustration. The connector loopback feature functions at all available interface speeds.

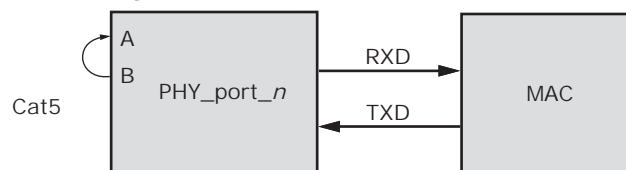
Figure 19 • Connector Loopback Diagram

When using the connector loopback testing feature, the device auto-negotiation, speed, and duplex configuration is set using device registers 0 and 4.

3.14.5 VeriPHY Cable Diagnostics

The VSC8530-04 device includes a comprehensive suite of cable diagnostic functions available using SMI reads and writes. These functions allow a variety of cable operating conditions and statuses to be accessed and checked. The VeriPHY suite has the ability to identify the cable length and operating conditions, and to isolate a number of common faults that can occur on the Cat5 twisted pair cabling.

Note: When a link is established in 100BASE-TX or 10BASE-T modes, VeriPHY causes the link to drop while the diagnostics are running. After diagnostics are finished, the link is re-established.

The following diagnostic functions are part of the VeriPHY suite.

- Detecting coupling between cable pairs
- Detecting cable pair termination
- Determining cable length

3.14.5.1 Coupling Between Cable Pairs

Shorted wires, improper termination, or high crosstalk resulting from an incorrect wire map can cause error conditions, such as anomalous coupling between cable pairs. These conditions can prevent the device from establishing a link in any speed.

3.14.5.2 Cable Pair Termination

Proper termination of a Cat5 cable pair requires a 100 Ω differential impedance between the positive and negative cable terminals. IEEE 802.3 allows for a termination between 85 Ω (minimum) and 115 Ω (maximum). If the termination falls outside of this range, the VeriPHY diagnostics report it as an anomalous termination. The diagnostics can also determine the presence of an open or shorted cable pair.

3.14.5.3 Cable Length

When the Cat5 cable in an installation is properly terminated, VeriPHY reports the approximate cable length (in meters). If there is a cable fault, the distance to the fault is reported. Cable length reporting is reliable for cables between 10 and 100 meters.

3.15 Configuration

The VSC8530-04 device can be configured by setting internal memory registers using the management interface or by using the unmanaged mode as described in [Unmanaged Mode](#), page 9.

3.15.1 Managed Applications

To configure the device using the management interface, perform the following steps:

1. Apply power.
2. Apply RefClk.
3. Release reset, drive high. Power and clock must be high before releasing reset.
4. Wait 15 ms minimum.
5. Apply patch from PHY_API if available (required for production release, optional for board testing).
6. Configure register 23 for MAC interface mode.
 - Read register 23 (to access register 23, register 31 must be 0).
 - Set bits 12:11, MAC configuration, as follows:
 - 10: RGMII
 - 01: RMII
 - Write new register 23.
7. Software reset.
 - Read register 0 (to access register 0, register 31 must be 0).
 - Set bit 15 to 1.
 - Write new register 0.
8. Read register 0 until bit 15 equals to 0.
9. For RGMII mode: Configure register 20E2 (to access register 20E2, register 31 must be set to 2). Set bit 11 to 0 and set RX_CLK delay and TX_CLK delay accordingly through bit [6:4] and/or bit [2:0] respectively.

3.15.2 Unmanaged Applications

To configure the device using unmanaged mode, perform the following steps:

1. Apply power.
2. Apply RefClk.
3. Release reset, drive high. Power and clock must be high before releasing reset.

Note: For unmanaged mode operation, the NRESET pin must have two rising edges (logical 0-1-0-1 transition sequence) applied at this step.

4. Wait 15 ms minimum.
5. (Optional) For applications that gain register access to the device using the management interface, steps 6–10 can then be performed in order to modify default settings.

4 Registers

This section provides information about how to configure the VSC8530-04 device using its internal memory registers and the management interface. The registers marked reserved and factory test should not be read or written to, because doing so may produce undesired effects.

The default value documented for registers is based on the value at reset; in some cases, that value may change immediately after reset.

The access type for each register is shown using the following abbreviations:

- RO: Read Only
- ROCR: Read Only, Clear on Read
- RO/LH: Read Only, Latch High
- RO/LL: Read Only, Latch Low
- R/W: Read and Write
- RWSC: Read and Write, Self-Clearing

The VSC8530-04 device uses several different types of registers:

- IEEE Clause 22 device registers with addresses from 0 to 31
- Two pages of extended registers with addresses from 17E1–30E1 and 16E2–30E2
- General-purpose registers with addresses from 0G to 30G
- IEEE Clause 45 devices registers accessible through the Clause 22 registers 13 and 14 to support IEEE 802.3az-2010 Energy-Efficient Ethernet registers and IEEE 802.3bf-2011 registers

The following illustration shows the relationship between the device registers and their address spaces.

Figure 20 • Register Space Diagram

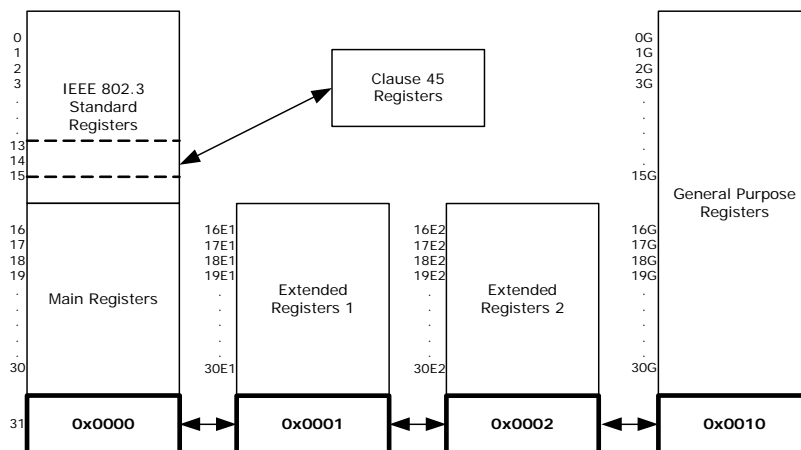

Reserved Registers

For main registers 16–31, extended registers 17E1–30E1, 16E2–30E2, and general purpose registers 0G–30G, any bits marked as Reserved should be processed as read-only and their states as undefined.

Reserved Bits

In writing to registers with reserved bits, use a read-modify-then-write technique, where the entire register is read but only the intended bits to be changed are modified. Reserved bits cannot be changed and their read state cannot be considered static or unchanging.

4.1 Register and Bit Conventions

This document refers to registers by their address and bit number in decimal notation. A range of bits is indicated with a colon. For example, a reference to address 26, bits 15 through 14 is shown as 26.15:14.

A register with an E and a number attached (such as 27E1) means it is a register contained within extended register page number 1. A register with a G attached (such as 13G) means it is a GPIO page register.

Bit numbering follows the IEEE standard with bit 15 being the most significant bit and bit 0 being the least significant bit.

4.2 IEEE 802.3 and Main Registers

In the VSC8530-04 device, the page space of the standard registers consists of the IEEE 802.3 standard registers and the Microsemi standard registers. The following table lists the names of the registers associated with the addresses as specified by IEEE 802.3.

Table 17 • IEEE 802.3 Registers

Address	Name
0	Mode Control
1	Mode Status
2	PHY Identifier 1
3	PHY Identifier 2
4	Auto-negotiation Advertisement
5	Auto-negotiation Link Partner Ability
6	Auto-negotiation Expansion
7	Auto-negotiation Next-Page Transmit
8	Auto-negotiation Link Partner Next-Page Receive
9–12	Reserved
13	MMD EEE Access
14	MMD Address or Data Register
15	Reserved

The following table lists the names of the registers in the main page space of the device. These registers are accessible only when register address 31 is set to 0x0000.

Table 18 • Main Registers

Address	Name
16	100BASE-TX status extension
17	Reserved
18	Bypass control
19	Error Counter 1
20	Error Counter 2
21	Error Counter 3
22	Extended control and status
23	Extended PHY control 1
24	Extended PHY control 2
25	Interrupt mask
26	Interrupt status
27	Reserved

Table 18 • Main Registers (continued)

Address	Name
28	Auxiliary control and status
29	LED mode select
30	LED behavior
31	Extended register page access

4.2.1 Mode Control

The device register at memory address 0 controls several aspects of the VSC8530-04 device functionality. The following table shows the available bit settings in this register and what they control.

Table 19 • Mode Control, Address 0 (0x00)

Bit	Name	Access	Description	Default
15	Software reset	R/W	Self-clearing. Restores all serial management interface (SMI) registers to default state, except for sticky and super-sticky bits. 1: Reset asserted. 0: Reset de-asserted. Wait 1 μ s after setting this bit to initiate another SMI register access.	0
14	Loopback	R/W	1: Loopback enabled. 0: Loopback disabled. When loopback is enabled, the device functions at the current speed setting and with the current duplex mode setting (bits 6, 8, and 13 of this register).	0
13	Forced speed selection LSB	R/W	Least significant bit. MSB is bit 6. 00: 10 Mbps 01: 100 Mbps 10: Reserved 11: Reserved	1
12	Autonegotiation enable	R/W	1: Autonegotiation enabled. 0: Autonegotiation disabled.	1
11	Power-down	R/W	1: Power down enabled.	0
10	Isolate	R/W	1: Disable MAC interface outputs and ignore MAC interface inputs.	0
9	Restart autonegotiation	R/W	Self-clearing bit. 1: Restart autonegotiation on media interface.	0
8	Duplex	R/W	1: Full-duplex. 0: Half-duplex.	0
7	Collision test enable	R/W	1: Collision test enabled.	0
6	Forced speed selection MSB	R/W	Most significant bit. LSB is bit 13. 00: 10 Mbps 01: 100 Mbps 10: Reserved 11: Reserved	0
5:0	Reserved		Reserved.	00000

4.2.2 Mode Status

The register at address 1 in the device main registers space enables reading the currently enabled mode setting. The following table shows possible readouts of this register.

Table 20 • Mode Status, Address 1 (0x01)

Bit	Name	Access	Description	Default
15	100BASE-T4 capability	RO	1: 100BASE-T4 capable.	0
14	100BASE-TX FDX capability	RO	1: 100BASE-TX FDX capable.	1
13	100BASE-TX HDX capability	RO	1: 100BASE-TX HDX capable.	1
12	10BASE-T FDX capability	RO	1: 10BASE-T FDX capable.	1
11	10BASE-T HDX capability	RO	1: 10BASE-T HDX capable.	1
10	100BASE-T2 FDX capability	RO	1: 100BASE-T2 FDX capable.	0
9	100BASE-T2 HDX capability	RO	1: 100BASE-T2 HDX capable.	0
8	Extended status enable	RO	1: Extended status information present in register 15.	1
7	Reserved	RO	Reserved.	
6	Preamble suppression capability	RO	1: MF preamble can be suppressed. 0: MF required.	1
5	Autonegotiation complete	RO	1: Auto-negotiation complete.	0
4	Remote fault	RO	Latches high. 1: Far-end fault detected.	0
3	Autonegotiation capability	RO	1: Auto-negotiation capable.	1
2	Link status	RO	Latches low. 1: Link is up.	0
1	Jabber detect	RO	Latches high. 1: Jabber condition detected.	0
0	Extended capability	RO	1: Extended register capable.	1

4.2.3 Device Identification

All 16 bits in both register 2 and register 3 in the VSC8530-04 device are used to provide information associated with aspects of the device identification. The following tables list the expected readouts.

Table 21 • Identifier 1, Address 2 (0x02)

Bit	Name	Access	Description	Default
15:0	Organizationally unique identifier (OUI)	RO	OUI most significant bits (3:18)	0x0007

Table 22 • Identifier 2, Address 3 (0x03)

Bit	Name	Access	Description	Default
15:10	OUI	RO	OUI least significant bits (19:24)	000001
9:4	Microsemi model number	RO	VSC8530-04	010110
3:0	Device revision number	RO	Revision B	0001

4.2.4 Auto-Negotiation Advertisement

The bits in address 4 in the main registers space control the ability to notify other devices of the status of its auto-negotiation feature. The following table shows the available settings and readouts.

Table 23 • Device Auto-Negotiation Advertisement, Address 4 (0x04)

Bit	Name	Access	Description	Default
15	Next page transmission request	R/W	1: Request enabled	0
14	Reserved	RO	Reserved	
13	Transmit remote fault	R/W	1: Enabled	0
12	Reserved	R/W	Reserved	0
11	Advertise asymmetric pause	R/W	1: Advertises asymmetric pause	0
10	Advertise symmetric pause	R/W	1: Advertises symmetric pause	0
9	Advertise100BASE-T4	R/W	1: Advertises 100BASE-T4	0
8	Advertise100BASE-TX FDX	R/W	1: Advertise 100BASE-TX FDX	1
7	Advertise100BASE-TX HDX	R/W	1: Advertises 100BASE-TX HDX	1
6	Advertise10BASE-T FDX	R/W	1: Advertises 10BASE-T FDX	1
5	Advertise10BASE-T HDX	R/W	1: Advertises 10BASE-T HDX	1
4:0	Advertise selector	R/W		00001

4.2.5 Link Partner Auto-Negotiation Capability

The bits in main register 5 can be used to determine if the Cat5 link partner (LP) used with the VSC8530-04 device is compatible with the auto-negotiation functionality.

Table 24 • Auto-Negotiation Link Partner Ability, Address 5 (0x05)

Bit	Name	Access	Description	Default
15	LP next page transmission request	RO	1: Requested	0
14	LP acknowledge	RO	1: Acknowledge	0
13	LP remote fault	RO	1: Remote fault	0
12	Reserved	RO	Reserved	
11	LP advertise asymmetric pause	RO	1: Capable of asymmetric pause	0
10	LP advertise symmetric pause	RO	1: Capable of symmetric pause	0
9	LP advertise 100BASE-T4	RO	1: Capable of 100BASE-T4	0
8	LP advertise 100BASE-TX FDX	RO	1: Capable of 100BASE-TX FDX	0
7	LP advertise 100BASE-TX HDX	RO	1: Capable of 100BASE-TX HDX	0
6	LP advertise 10BASE-T FDX	RO	1: Capable of 10BASE-T FDX	0
5	LP advertise 10BASE-T HDX	RO	1: Capable of 10BASE-T HDX	0
4:0	LP advertise selector	RO		00000

4.2.6 Auto-Negotiation Expansion

The bits in main register 6 work together with those in register 5 to indicate the status of the LP auto-negotiation functioning. The following table shows the available settings and readouts.

Table 25 • Auto-Negotiation Expansion, Address 6 (0x06)

Bit	Name	Access	Description	Default
15:5	Reserved	RO	Reserved.	
4	Parallel detection fault	RO	This bit latches high. 1: Parallel detection fault.	0
3	LP next page capable	RO	1: LP is next page capable.	0
2	Local PHY next page capable	RO	1: Local PHY is next page capable.	1
1	Page received	RO	This bit latches high. 1: New page is received.	0
0	LP is autonegotiation capable	RO	1: LP is capable of auto-negotiation.	0

4.2.7 Transmit Auto-Negotiation Next Page

The settings in register 7 in the main registers space provide information about the number of pages in an auto-negotiation sequence. The following table shows the settings available.

Table 26 • Auto-Negotiation Next Page Transmit, Address 7 (0x07)

Bit	Name	Access	Description	Default
15	Next page	R/W	1: More pages follow.	0
14	Reserved	RO	Reserved.	
13	Message page	R/W	1: Message page. 0: Unformatted page.	1
12	Acknowledge 2	R/W	1: Complies with request. 0: Cannot comply with request.	0
11	Toggle	RO	1: Previous transmitted LCW = 0. 0: Previous transmitted LCW = 1.	0
10:0	Message/unformatted code	R/W		0000000001

4.2.8 Auto-Negotiation Link Partner Next Page Receive

The bits in register 8 of the main register space work together with register 7 to determine certain aspects of the LP auto-negotiation. The following table shows the possible readouts.

Table 27 • Auto-Negotiation LP Next Page Receive, Address 8 (0x08)

Bit	Name	Access	Description	Default
15	LP next page	RO	1: More pages follow.	0
14	Acknowledge	RO	1: LP acknowledge.	0
13	LP message page	RO	1: Message page. 0: Unformatted page.	0
12	LP acknowledge 2	RO	1: LP complies with request.	0
11	LP toggle	RO	1: Previous transmitted LCW = 0. 0: Previous transmitted LCW = 1.	0
10:0	LP message/unformatted code	RO		All zeros

4.2.9 MMD Access Control Register

The bits in register 13 of the main register space are a window to the EEE registers as defined in IEEE 802.3az-2010 Clause 45.

Table 28 • MMD EEE Access, Address 13 (0x0D)

Bit	Name	Access	Description
15:14	Function	R/W	00: Address. 01: Data, no post increment. 10: Data, post increment for read and write. 11: Data, post increment for write only.
13:5	Reserved	RO	Reserved.
4:0	DVAD	R/W	Device address as defined in IEEE 802.3az-2010 table 45–1.

4.2.10 MMD Address or Data Register

The bits in register 14 of the main register space are a window to the EEE registers as defined in IEEE 802.3az-2010 Clause 45.

Table 29 • MMD Address or Data Register, Address 14 (0x0E)

Bit	Name	Access	Description
15:0	Register Address/Data	R/W	When register 13.15:14 = 2'b00, address of register of the device that is specified by 13.4:0. Otherwise, the data to be written to or read from the register.

4.2.11 100BASE-TX Status Extension

Register 16 in the main registers page space provides additional information about the status of the 100BASE-TX operation.

Table 30 • 100BASE-TX Status Extension, Address 16 (0x10)

Bit	Name	Access	Description	Default
15	100BASE-TX Descrambler	RO	1: Descrambler locked.	0
14	100BASE-TX lock error	RO	Self-clearing bit. 1: Lock error detected.	0
13	100BASE-TX disconnect state	RO	Self-clearing bit. 1: PHY 100BASE-TX link disconnect detected.	0
12	100BASE-TX current link status	RO	1: PHY 100BASE-TX link active.	0
11	100BASE-TX receive error	RO	Self-clearing bit. 1: Receive error detected.	0
10	100BASE-TX transmit error	RO	Self-clearing bit. 1: Transmit error detected.	0
9	100BASE-TX SSD error	RO	Self-clearing bit. 1: Start-of-stream delimiter error detected.	0
8	100BASE-TX ESD error	RO	Self-clearing bit. 1: End-of-stream delimiter error detected.	0
7:0	Reserved	RO	Reserved.	

4.2.12 Bypass Control

The bits in this register control aspects of functionality in effect when the device is disabled for the purpose of traffic bypass. The following table shows the settings available.

Table 31 • Bypass Control, Address 18 (0x12)

Bit	Name	Access	Description	Default
15	Transmit disable	R/W	1: PHY transmitter disabled.	0
14	4B5B encoder/decoder	R/W	1: Bypass 4B/5B encoder/decoder.	0
13	Scrambler	R/W	1: Bypass scrambler.	0
12	Descrambler	R/W	1: Bypass descrambler.	0
11	PCS receive	R/W	1: Bypass PCS receiver.	0
10	PCS transmit	R/W	1: Bypass PCS transmit.	0
9	LFI timer	R/W	1: Bypass Link Fail Inhibit (LFI) timer.	0
8	Reserved	RO	Reserved.	
7	HP Auto-MDIX at forced 10/100	R/W	Sticky bit. 1: Disable HP Auto-MDIX at forced 10/100 speeds.	1
6	Reserved	R/W	Reserved.	0
5	Disable pair swap correction (HP Auto-MDIX when autonegotiation enabled)	R/W	Sticky bit. 1: Disable the automatic pair swap correction.	0
4	Disable polarity correction	R/W	Sticky bit. 1: Disable polarity inversion correction on each subchannel.	0
3	Parallel detect control	R/W	Sticky bit. 1: Do not ignore advertised ability. 0: Ignore advertised ability.	1
20	Reserved	RO	Reserved.	

4.2.13 Error Counter 1

The bits in register 19 provide an error counter. The following table shows the settings available.

Table 32 • Extended Control and Status, Address 19 (0x13)

Bit	Name	Access	Description	Default
15:8	Reserved	RO	Reserved.	
7:0	Receive error counter	RO	8-bit counter that saturates when it reaches 255. These bits are self-clearing when read.	0x00

4.2.14 Error Counter 2

The bits in register 20 provide an error counter. The following table shows the settings available.

Table 33 • Extended Control and Status, Address 20 (0x14)

Bit	Name	Access	Description	Default
15:8	Reserved	RO	Reserved.	
7:0	False carrier counter	RO	8-bit counter that saturates when it reaches 255. These bits are self-clearing when read.	0x00

4.2.15 Error Counter 3

The bits in register 21 provide an error counter. The following table shows the settings available.

Table 34 • Extended Control and Status, Address 21 (0x15)

Bit	Name	Access	Description	Default
15:8	Reserved	RO	Reserved.	
7:0	Copper media link disconnect counter	RO	8-bit counter that saturates when it reaches 255. These bits are self-clearing when read.	0x00

4.2.16 Extended Control and Status

The bits in register 22 provide additional device control and readouts. The following table shows the settings available.

Table 35 • Extended Control and Status, Address 22 (0x16)

Bit	Name	Access	Description	Default
15	Force 10BASE-T link high	R/W	Sticky bit. 1: Bypass link integrity test. 0: Enable link integrity test.	0
14	Jabber detect disable	R/W	Sticky bit. 1: Disable jabber detect.	0
13	Disable 10BASE-T echo	R/W	Sticky bit. 1: Disable 10BASE-T echo.	1
12	Disable SQE mode	R/W	Sticky bit. 1: Disable SQE mode.	1
11:10	10BASE-T squelch control	R/W	Sticky bit. 00: Normal squelch. 01: Low squelch. 10: High squelch. 11: Reserved.	00
9	Sticky reset enable	R/W	Super-sticky bit. 1: Enabled.	1
8	EOF Error	RO	This bit is self-clearing. 1: EOF error detected.	0
7	10BASE-T disconnect state	RO	This bit is self-clearing. 1: 10BASE-T link disconnect detected.	0
6	10BASE-T link status	RO	1: 10BASE-T link active.	0
5:1	Reserved	RO	Reserved.	
0	SMI broadcast write	R/W	Sticky bit. 1: Enabled.	0

The following information applies to the extended control and status bits:

- When bit 22.15 is set, the link integrity state machine is bypassed and the PHY is forced into a link pass status.
- When bits 22.11:10 are set to 00, the squelch threshold levels are based on the IEEE standard for 10BASE-T. When set to 01, the squelch level is decreased, which can improve the bit error rate performance on long loops. When set to 10, the squelch level is increased and can improve the bit error rate in high-noise environments.

- When bit 22.9 is set, all sticky register bits retain their values during a software reset. Clearing this bit causes all sticky register bits to change to their default values upon software reset. Super-sticky bits retain their values upon software reset regardless of the setting of bit 22.9.
- When bit 22.0 is set, if a write to any PHY register (registers 0–31, including extended registers), the same write is broadcast to all PHYs. For example, if bit 22.0 is set to 1 and a write to PHY0 is executed (register 0 is set to 0x1040), all PHYs' register 0s are set to 0x1040. Disabling this bit restores normal PHY write operation. Reads are still possible when this bit is set, but the value that is read corresponds only to the particular PHY being addressed.

4.2.17 Extended PHY Control 1

The following table shows the settings available.

Table 36 • Extended PHY Control 1, Address 23 (0x17)

Bit	Name	Access	Description	Default
15:14	Reserved	RO	Reserved.	
13	MAC supplied clock enable	R/W	MAC interface RX_CLK synchronization. 0: Synchronize RX_CLK to recovered clock. 1: Synchronize RX_CLK to REFCLK. Note: This bit is not applicable to the RMII MAC interface selection. This bit may be changed or written prior to a soft-reset, after which it takes effect.	0
12:11	MAC interface selection	R/W	MAC interface mode. 00: Reserved. 01: RMII. 10: RGMII. 11: Reserved. Note: These bits may be changed or written prior to a soft-reset, after which it takes effect.	10
10:4	Reserved	RO	Reserved.	
3	Far-end loopback mode	R/W	1: Enabled.	0
2:0	Reserved	RO	Reserved.	

Note: After configuring bits 13:11 of the extended PHY control register set 1, a software reset (register 0, bit 15) must be written to change the device operating mode. On read, these bits only indicate the actual operating mode and not the pending operating mode setting before a software reset has taken place.

4.2.18 Extended PHY Control 2

The second set of extended controls is located in register 24 in the main register space for the device. The following table shows the settings and readouts available.

Table 37 • Extended PHY Control 2, Address 24 (0x18)

Bit	Name	Access	Description	Default
15:13	100BASE-TX edge rate control	R/W	Sticky bit. 011: +7 edge rate (slowest). 010: +6 edge rate. 001: +5 edge rate. 000: +4 edge rate. 111: +3 edge rate. 110: +2 edge rate. 101: +1 edge rate. 100: Fastest edge rate.	000

Table 37 • Extended PHY Control 2, Address 24 (0x18) (continued)

Bit	Name	Access	Description	Default
12	PICMG 2.16 reduced power mode	R/W	Sticky bit. 1: Enabled.	0
11:6	Reserved	RO	Reserved.	
5:4	Jumbo packet mode	R/W	Sticky bit. 00: Normal IEEE 1.5 kB packet length. 01: 9 kB jumbo packet length (12 kB with 60 ppm or better reference clock). 10: 12 kB jumbo packet length (16 kB with 70 ppm or better reference clock). 11: Reserved.	00
3:1	Reserved	RO	Reserved.	
0	Connector loopback	R/W	1: Enabled.	0

Note: When bits 5:4 are set to jumbo packet mode, the default maximum packet values are based on 100 ppm driven reference clock to the device. Controlling the ppm offset between the MAC and the PHY as specified in the bit description results in a higher jumbo packet length.

4.2.19 Interrupt Mask

These bits control the device interrupt mask. The following table shows the settings available.

Table 38 • Interrupt Mask, Address 25 (0x19)

Bit	Name	Access	Description	Default
15	MDINT interrupt status enable	R/W	Sticky bit. 1: Enabled.	0
14	Speed state change mask	R/W	Sticky bit. 1: Enabled.	0
13	Link state change mask	R/W	Sticky bit. 1: Enabled.	0
12	FDX state change mask	R/W	Sticky bit. 1: Enabled.	0
11	Autonegotiation error mask	R/W	Sticky bit. 1: Enabled.	0
10	Autonegotiation complete mask	R/W	Sticky bit. 1: Enabled.	0
9	Inline-powered device (PoE) detect mask	R/W	Sticky bit. 1: Enabled.	0
8	Symbol error interrupt mask	R/W	Sticky bit. 1: Enabled.	0
7	Fast link failure interrupt mask	R/W	Sticky bit. 1: Enabled.	0
6	Wake-on-LAN event interrupt mask	R/W	Sticky bit. 1: Enabled.	0
5	Extended interrupt mask	R/W	Sticky bit. 1: Enabled.	0
4	Reserved	R/W	Reserved.	0
3	False carrier interrupt mask	R/W	Sticky bit. 1: Enabled.	0
2	Reserved	R/W	Reserved.	0
1	Reserved	R/W	Reserved.	0
0	RX_ER interrupt mask	R/W	Sticky bit. 1: Enabled.	0

Note: When bit 25.15 is set, the MDINT pin is enabled. When enabled, the state of this pin reflects the state of bit 26.15. Clearing this bit only inhibits the MDINT pin from being asserted. Also, before enabling this bit, read register 26 to clear any previously inactive interrupts pending that will cause bit 25.15 to be set.

4.2.20 Interrupt Status

The status of interrupts already written to the device is available for reading from register 26 in the main registers space. The following table shows the expected readouts.

Table 39 • Interrupt Status, Address 26 (0x1A)

Bit	Name	Access	Description	Default
15	Interrupt status	RO	Self-clearing bit. 1: Interrupt pending.	0
14	Speed state change status	RO	Self-clearing bit. 1: Interrupt pending.	0
13	Link state change status	RO	Self-clearing bit. 1: Interrupt pending.	0
12	FDX state change status	RO	Self-clearing bit. 1: Interrupt pending.	0
11	Autonegotiation error status	RO	Self-clearing bit. 1: Interrupt pending.	0
10	Autonegotiation complete status	RO	Self-clearing bit. 1: Interrupt pending.	0
9	Inline powered device detect status	RO	Self-clearing bit. 1: Interrupt pending.	0
8	Symbol error status	RO	Self-clearing bit. 1: Interrupt pending.	0
7	Fast link failure detect status	RO	Self-clearing bit. 1: Interrupt pending.	0
6	Wake-on-LAN event status	RO	Self-clearing bit. 1: Interrupt pending.	0
5	Extended interrupt status	RO	Self-clearing bit. 1: Interrupt pending.	0
4	Reserved	RO	Reserved.	
3	False carrier interrupt status	RO	Self-clearing bit. 1: Interrupt pending.	0
2	Reserved	RO	Reserved.	
1	Reserved	RO	Reserved.	
0	RX_ER interrupt status	RO	Self-clearing bit. 1: Interrupt pending.	0

The following information applies to the interrupt status bits:

- All set bits in this register are cleared after being read (self-clearing). If bit 26.15 is set, the cause of the interrupt can be read by reading bits 26.14:0.
- For bits 26.14 and 26.12, bit 0.12 must be set for this interrupt to assert.
- For bit 26.0, this interrupt will not occur when RX_ER is used for carrier-extension decoding of a link partner's data transmission.
- If bit 5 is set, register 29E2 must be read to determine the source of the interrupt.

4.2.21 Device Auxiliary Control and Status

Register 28 provides control and status information for several device functions not controlled or monitored by other device registers. The following table shows the settings available and the expected readouts.

Table 40 • Auxiliary Control and Status, Address 28 (0x1C)

Bit	Name	Access	Description	Default
15	Autonegotiation complete	RO	Duplicate of bit 1.5 when auto-negotiation is enabled, otherwise this is the current link status.	0
14	Autonegotiation disabled	RO	Inverted duplicate of bit 0.12.	0
13	HP Auto-MDIX crossover indication	RO	1: HP Auto-MDIX crossover performed internally.	0
12	Reserved	RO	Reserved.	

Table 40 • Auxiliary Control and Status, Address 28 (0x1C) (continued)

Bit	Name	Access	Description	Default
11	A polarity inversion	RO	1: Polarity swap on pair A.	0
10	B polarity inversion	RO	1: Polarity swap on pair B.	0
9:8	Reserved	RO	Reserved.	
7	ActiPHY link status time-out control [1]	R/W	Sticky bit. Bits 7 and 2 are part of the ActiPHY Link Status time-out control. Bit 7 is the MSB. 00: 2.3 seconds. 01: 3.3 seconds. 10: 4.3 seconds. 11: 5.3 seconds.	0
6	ActiPHY mode enable	R/W	Sticky bit. 1: Enabled.	0
5	FDX status	RO	1: Full-duplex. 0: Half-duplex.	0
4:3	Speed status	RO	00: Speed is 10BASE-T. 01: Speed is 100BASE-TX. 10: Reserved. 11: Reserved.	00
2	ActiPHY link status time-out control [0]	R/W	Sticky bit. Bits 7 and 2 are part of the ActiPHY Link Status time-out control. Bit 7 is the MSB. 00: 2.3 seconds. 01: 3.3 seconds. 10: 4.3 seconds. 11: 5.3 seconds.	1
1:0	Media mode status	RO	00: No media selected. 01: Copper media selected. 10: Reserved. 11: Reserved.	00

4.2.22 LED Mode Select

The device LED outputs are controlled using the bits in register 29 of the main register space. The following table shows the information needed to access the functionality of each of the outputs. For more information about LED modes, see [Table 13](#), page 17. For information about enabling the extended LED mode bits in Register 19E1 bits 13 to 12, see [Table 15](#), page 19.

Table 41 • LED Mode Select, Address 29 (0x1D)

Bit	Name	Access	Description	Default
15	Reserved	RO	Reserved.	
14:8	Reserved	R/W	Reserved.	0x00
7:4	LED1 mode select	R/W	Sticky bit. Select from LED modes 0–15.	0010
3:0	LED0 mode select	R/W	Sticky bit. Select from LED modes 0–15.	0001

4.2.23 LED Behavior

The bits in register 30 control and enable you to read the status of the pulse or blink rate of the device LEDs. The following table shows the settings you can write to the register or read from the register.

Table 42 • LED Behavior, Address 30 (0x1E)

Bit	Name	Access	Description	Default
15:13	Reserved	RO	Reserved.	
12	LED pulsing enable	R/W	Sticky bit. 0: Normal operation. 1: LEDs pulse with a 5 kHz, programmable duty cycle when active.	0
11:10	LED blink/pulse-stretch rate	R/W	Sticky bit. 00: 2.5 Hz blink rate/400 ms pulse-stretch. 01: 5 Hz blink rate/200 ms pulse-stretch. 10: 10 Hz blink rate/100 ms pulse-stretch. 11: 20 Hz blink rate/50 ms pulse-stretch. The blink rate selection sets the rate used for all LED pins.	01
9:7	Reserved	RO	Reserved.	
6	LED1 pulse-stretch/blink select	R/W	Sticky bit. 1: Pulse-stretch. 0: Blink.	0
5	LED0 pulse-stretch/blink select	R/W	Sticky bit. 1: Pulse-stretch. 0: Blink.	0
4:2	Reserved	RO	Reserved.	
1	LED1 combine feature disable	R/W	Sticky bit. 0: Combine enabled (link/activity, duplex/collision). 1: Disable combination (link only, duplex only).	0
0	LED0 combine feature disable	R/W	Sticky bit. 0: Combine enabled (link/activity, duplex/collision). 1: Disable combination (link only, duplex only).	0

Note: Bits 30.11:10 are active only in port 0 and affect the behavior of LEDs for all the ports.

4.2.24 Extended Page Access

To provide functionality beyond the IEEE 802.3-specified registers and main device registers, an extended set of registers provide an additional 15 register spaces.

The register at address 31 controls access to the extended registers. Accessing the GPIO page register space is similar to accessing the extended page registers. The following table shows the settings available.

Table 43 • Extended/GPIO Register Page Access, Address 31 (0x1F)

Bit	Name	Access	Description	Default
15:0	Extended/GPIO page register access	R/W	0x0000: Register 16–30 accesses main register space. Writing 0x0000 to register 31 restores the main register access. 0x0001: Registers 16–30 access extended register space 1. 0x0002: Registers 16–30 access extended register space 2. 0x0010: Registers 0–30 access GPIO register space.	0x0000

4.3 Extended Page 1 Registers

To access the extended page 1 registers (17E1–30E1), enable extended register access by writing 0x0001 to register 31. Writing 0x0000 to register 31 restores the main register access.

When extended page 1 register access is enabled, reads and writes to registers 16–30 affect the extended registers 17E1–30E1 instead of those same registers in the IEEE-specified register space. Registers 0–15 are not affected by the state of the extended page register access.

Table 44 • Extended Registers Page 1 Space

Address	Name
16E1	VeriPHY Status Register 1
17E1	Reserved
18E1	Cu Media CRC Good Counter
19E1	Extended Mode Control
20E1	Extended PHY Control 3 (ActiPHY)
21E1–22E1	Reserved
23E1	Extended PHY Control 4 (PoE and CRC Error Counter)
24E1	VeriPHY Control 1
25E1	VeriPHY Control 2
26E1	VeriPHY Control 3
27E1–28E1	Reserved
29E1	Ethernet Packet Generator (EPG) 1
30E1	EPG 2

4.3.1 VeriPHY Status 1

Register 16E1 in the extended register space provides status of the VeriPHY diagnostics for pairs A and B. These results are valid when bit 24E1.14 is set to 1.

Table 45 • VeriPHY Status Register 1, Address 16E1 (0x10)

Bit	Name	Access	Description	Default
15:8	Pair B (3, 6) distance	RO	Loop length or distance to anomaly for pair B (3, 6)	0x00
7:0	Pair A (1, 2) distance	RO	Loop length or distance to anomaly for pair A (1, 2)	0x00

Note: The resolution of the 8-bit length field is 1 meter.

4.3.2 Cu Media CRC Good Counter

Register 18E1 makes it possible to read the contents of the CRC good counter for packets that are received on the Cu media interface: the number of CRC routines that have executed successfully. The following table shows the expected readouts.

Table 46 • Cu Media CRC Good Counter, Address 18E1 (0x12)

Bit	Name	Access	Description	Default
15	Packet since last read	RO	Self-clearing bit. 1: Packet received since last read.	0
14	Reserved	RO	Reserved.	

Table 46 • Cu Media CRC Good Counter, Address 18E1 (0x12) (continued)

Bit	Name	Access	Description	Default
13:0	Cu Media CRC good counter contents	RO	Self-clearing bit. Counter containing the number of packets with valid CRCs modulo 10,000; this counter does not saturate and will roll over to zero on the next good packet received after 9,999.	0x0000

4.3.3 Extended Mode Control

Register 19E1 controls the extended LED and other chip modes. The following table shows the settings available.

Table 47 • Extended Mode Control, Address 19E1 (0x13)

Bit	Name	Access	Description	Default
15:14	Reserved	R/W	Reserved.	00
13	LED1 Extended Mode	R/W	Sticky bit. 1: See Basic Serial LED Mode , page 18.	0
12	LED0 Extended Mode	R/W	Sticky bit. 1: See Basic Serial LED Mode , page 18.	0
11	LED Reset Blink Suppress	R/W	Sticky bit. 1: Blink LEDs after Software reset is de-asserted. 0: Suppress LED blink after Software reset is de-asserted.	0
10:4	Reserved	RO	Reserved.	
3:2	Force MDI crossover	R/W	Sticky bit. 00: Normal HP Auto-MDIX operation. 01: Reserved. 10: Copper media forced to MDI. 11: Copper media forced MDI-X.	00
1	Reserved	RO	Reserved.	
0	Reserved	R/W	Reserved.	0

4.3.4 ActiPHY Control

Register 20E1 controls the device ActiPHY sleep timer and its wake-up timer. The following table shows the settings available.

Table 48 • Extended PHY Control 3, Address 20E1 (0x14)

Bit	Name	Access	Description	Default
15	Reserved	RO	Reserved.	
14:13	ActiPHY sleep timer	R/W	Sticky bit. 00: 1 second. 01: 2 seconds. 10: 3 seconds. 11: 4 seconds.	01
12:11	ActiPHY wake-up timer	R/W	Sticky bit. 00: 160 ms. 01: 400 ms. 10: 800 ms. 11: 2 seconds.	00

Table 48 • Extended PHY Control 3, Address 20E1 (0x14) (continued)

Bit	Name	Access	Description	Default
10	Slow MDC	R/W	Sticky bit. 1: Indicates that MDC runs at less than 1 MHz (use of this bit is optional and indicated when MDC runs at less than 1 MHz).	0
9:8	Reserved	RO	Reserved.	
7:6	Media mode status	RO	00: No media selected. 01: Copper media selected. 10: Reserved. 11: Reserved.	00
5	Enable 10BASE-T no preamble mode	R/W	Sticky bit. 1: 10BASE-T will assert RX_DV indication when data is presented to the receiver even without a preamble preceding it.	0
4:0	Reserved	RO	Reserved.	

4.3.5 PoE and Miscellaneous Functionality

The register at address 23E1 controls various aspects of inline-powering and the CRC error counter in the VSC8530-04 device.

Table 49 • Extended PHY Control 4, Address 23E1 (0x17)

Bit	Name	Access	Description	Default
15:11	PHY address	RO	Internal PHY address: 0–31.	
10	Inline powered device detection	R/W	Sticky bit. 1: Enabled.	0
9:8	Inline powered device detection status	RO	Only valid when bit 10 is set. 00: Searching for devices. 01: Device found; requires inline-power. 10: Device found; does not require inline-power. 11: Reserved.	00
7:0	Cu Media CRC error counter	RO	Self-clearing 8-bit error count register.	

4.3.6 VeriPHY Control 1

Register 24E1 in the extended register space provides control over the device VeriPHY diagnostics features. There are three separate VeriPHY control registers. The following table shows the settings available and describes the expected readouts.

Table 50 • VeriPHY Control Register 1, Address 24E1 (0x18)

Bit	Name	Access	Description	Default
15	VeriPHY trigger	R/W	Self-clearing bit. 1: Triggers the VeriPHY algorithm and clears when VeriPHY has completed. Settings in registers 24E–26E become valid after this bit clears.	0
14	VeriPHY valid	RO	1: VeriPHY results in registers 24E–26E are valid.	0
13:8	Pair A (1, 2) distance	RO	Loop length or distance to anomaly for pair A (1, 2).	0x00

Table 50 • VeriPHY Control Register 1, Address 24E1 (0x18) (continued)

Bit	Name	Access	Description	Default
7:6	Reserved	RO	Reserved.	
5:0	Pair B (3, 6) distance	RO	Loop length or distance to anomaly for pair B (3, 6).	0x00

Note: The resolution of the 6-bit length field is 3 meters.

4.3.7 VeriPHY Control 2

The register at address 25E1 consists of the second of the three device registers that provide control over VeriPHY diagnostics features. The following table shows the expected readouts.

Table 51 • VeriPHY Control Register 2, Address 25E1 (0x19)

Bit	Name	Access	Description	Default
15:0	Reserved	RO	Reserved	0x0000

Note: The resolution of the 6-bit length field is 3 meters.

4.3.8 VeriPHY Control 3

The register at address 26E1 consists of the third of the three device registers that provide control over VeriPHY diagnostics features. Specifically, this register provides information about the termination status (fault condition) for all link partner pairs. The following table shows the expected readouts.

Table 52 • VeriPHY Control Register 3, Address 26E1 (0x1A)

Bit	Name	Access	Description	Default
15:12	Pair A (1, 2) termination status	RO	Termination fault for pair A (1, 2)	0x00
11:8	Pair B (3, 6) termination status	RO	Termination fault for pair B (3, 4)	0x00
7:0	Reserved	RO	Reserved	

The following table shows the meanings for the various fault codes.

Table 53 • VeriPHY Control Register 3 Fault Codes

Code	Denotes
0000	Correctly terminated pair
0001	Open pair
0010	Shorted pair
0100	Abnormal termination
1000	Cross-pair short to pair A
1001	Cross-pair short to pair B
1100	Abnormal cross-pair coupling with pair A
1101	Abnormal cross-pair coupling with pair B

4.3.9 Ethernet Packet Generator (EPG) Control 1

The EPG control register provides access to and control of various aspects of the EPG testing feature. There are two separate EPG control registers. The following table shows the settings available in the first register.

Table 54 • EPG Control Register 1, Address 29E1 (0x1D)

Bit	Name	Access	Description	Default
15	EPG enable ¹	R/W	1: Enable EPG.	0
14	EPG run or stop	R/W	1: Run EPG.	0
13	Transmission duration	R/W	1: Continuous (sends in 10,000-packet increments). 0: Send 30,000,000 packets and stop.	0
12:11	Packet length	R/W	00: 125 bytes. 01: 64 bytes. 10: 1518 bytes. 11: 10,000 bytes (jumbo packet).	00
10	Interpacket gap	R/W	1: 8,192 ns. 0: 96 ns.	0
9:6	Destination address	R/W	Lowest nibble of the 6-byte destination address.	0001
5:2	Source address	R/W	Lowest nibble of the 6-byte destination address.	0000
1	Payload type	R/W	1: Randomly generated payload pattern. 0: Fixed based on payload pattern.	0
0	Bad frame check sequence (FCS) generation	R/W	1: Generate packets with bad FCS. 0: Generate packets with good FCS.	0

- To end forced transmission of EEE LPIs from the PHY, clear the force EEE LPI bit (17E2.4) first before clearing the EPG enable bit (29E1.15).

The following information applies to the EPG control number 1:

- Do not run the EPG when the VSC8530-04 device is connected to a live network.
- Bit 29E1.13 (continuous EPG mode control): when enabled, this mode causes the device to send continuous packets. When disabled, the device continues to send packets only until it reaches the next 10,000-packet increment mark. It then ceases to send packets.
- The 6-byte destination address in bits 9:6 is assigned one of 16 addresses in the range of 0xFF FF FF FF F0 through 0xFF FF FF FF FF.
- The 6-byte source address in bits 5:2 is assigned one of 16 addresses in the range of 0xFF FF FF FF F0 through 0xFF FF FF FF FF.
- If any of bits 13:0 are changed while the EPG is running (bit 14 is set to 1), bit 14 must be cleared and then set back to 1 for the change to take effect and to restart the EPG.

4.3.10 Ethernet Packet Generator Control 2

Register 30E1 consists of the second set of bits that provide access to and control over the various aspects of the EPG testing feature. The following table shows the settings available.

Table 55 • EPG Control Register 2, Address 30E1 (0x1E)

Bit	Name	Access	Description	Default
15:0	EPG packet payload	R/W	Data pattern repeated in the payload of packets generated by the EPG	0x0000

Note: If any of bits 15:0 in this register are changed while the EPG is running (bit 14 of register 29E1 is set to 1), that bit (29E1.14) must first be cleared and then set back to 1 for the change to take effect and to restart the EPG.

4.4 Extended Page 2 Registers

To access the extended page 2 registers (16E2–30E2), enable extended register access by writing 0x0002 to register 31. For more information, see [Table 43](#), page 37.

When extended page 2 register access is enabled, reads and writes to registers 16–30 affect the extended registers 16E2–30E2 instead of those same registers in the IEEE-specified register space. Registers 0–15 are not affected by the state of the extended page register access.

Writing 0x0000 to register 31 restores the main register access.

The following table lists the addresses and register names in the extended register page 2 space. These registers are accessible only when the device register 31 is set to 0x0002.

Table 56 • Extended Registers Page 2 Space

Address	Name
16E2	Cu PMD Transmit Control
17E2	EEE Control
18E2–19E2	Reserved
20E2	RGMII Control
21E2	Wake-on-LAN MAC Address [15:0]
22E2	Wake-on-LAN MAC Address [31:16]
23E2	Wake-on-LAN MAC Address [47:32]
24E2	Secure-On Password [15:0]
25E2	Secure-On Password [31:16]
26E2	Secure-On Password [47:32]
27E2	Wake-on-LAN and MAC Interface Control
28E2	Extended Interrupt Mask
29E2	Extended Interrupt Status
30E2	Reserved

4.4.1 Cu PMD Transmit Control

The register at address 16E2 consists of the bits that provide control over the amplitude settings for the transmit side Cu PMD interface. These bits provide the ability to make small adjustments in the signal amplitude to compensate for minor variations in the magnetics from different vendors. Extreme caution must be exercised when changing these settings from the default values as they have a direct impact on the signal quality. Changing these settings also affects the linearity and harmonic distortion of the transmitted signals. For help with changing these values, contact your Microsemi representative.

Table 57 • Cu PMD Transmit Control, Address 16E2 (0x10)

Bit	Name	Access	Description	Default
15:12	Reserved	RO	Reserved	

Table 57 • Cu PMD Transmit Control, Address 16E2 (0x10) (continued)

Bit	Name	Access	Description	Default
11:8	100BASE-TX signal amplitude trim ¹	R/W	Sticky bit. 100BASE-TX signal amplitude 0000: 1.8% 0001: 2.7% 0010: 3.6% 0011: 4.5% 0100: 5.4% 0101: 6.3% 0110: 7.2% 0111 8.1% 1000: -8% 1001: -6.2% 1010: -4.4% 1011: -2.7% 1100: -1.8% 1101: -0.9% 1110: 0% 1111: 0.9%	0010
7:4	10BASE-T signal amplitude trim ²	R/W	Sticky bit. 10BASE-T signal amplitude 0000: 0% 0001: 0.9% 0010: 1.8% 0011: 2.7% 0100: 3.6% 0101: 4.5% 0110: 5.4% 0111: 6.1% 1000: -7.2% 1001: -6.3% 1010: -5.4% 1011: -4.5% 1100: -3.6% 1101: -2.7% 1110: -1.8% 1111: -0.9%	1000

Table 57 • Cu PMD Transmit Control, Address 16E2 (0x10) (continued)

Bit	Name	Access	Description	Default
3:0	10BASE-Te signal amplitude trim	R/W	Sticky bit. 10BASE-Te signal amplitude 0000: 0% 0001: 0.65% 0010: 1.3% 0011: 1.95% 0100: 2.6% 0101: 3.25% 0110: 3.9% 0111: 4.55% 1000: -5.2% 1001: -4.55% 1010: -3.9% 1011: -3.25% 1100: -2.6% 1101: -1.95% 1110: -1.3% 1111: -0.65%	1110

1. Adjust 100BASE-TX to specific magnetics.
2. Amplitude is limited by V_{CC} (2.5 V).

4.4.2 EEE Control

The register at address 17E2 consists of the bits that provide additional control over the chip behavior in energy-efficient Ethernet (IEEE 802.3az-2010) mode for debug.

Table 58 • EEE Control, Address 17E2 (0x11)

Bit	Name	Access	Description	Default
15	Enable 10BASE-Te	R/W	Sticky bit. Enable energy efficient (IEEE 802.3az-2010) 10BASE-Te operating mode.	0
14:12	Reserved	RO	Reserved.	
11:10	Invert LED polarity	R/W	Sticky bit. Invert polarity of LED signals. Default is to drive an active low signal on the LED pins. For more information, see Extended LED Modes , page 19.	00
9	Reserved	RO	Reserved.	
8	Link status	RO	1: Link is up.	0
7	Reserved	RO	Reserved.	
6	100BASE-TX EEE enable	RO	1: EEE is enabled for 100BASE-TX.	0
5	Reserved	RO	Reserved.	
4	Force transmit LPI ¹	R/W	Sticky bit. 1: Enable the EPG to transmit LPI on the MDI, ignore data from the MAC interface. 0: Transmit idles being received from the MAC.	0

Table 58 • EEE Control, Address 17E2 (0x11) (continued)

Bit	Name	Access	Description	Default
3	Inhibit 100BASE-TX transmit EEE LPI	R/W	Sticky bit. 1: Disable transmission of EEE LPI on transmit path MDI in 100BASE-TX mode when receiving LPI from MAC.	0
2	Inhibit 100BASE-TX receive EEE LPI	R/W	Sticky bit. 1: Disable transmission of EEE LPI on receive path MAC interface in 100BASE-TX mode when receiving LPI from the MDI.	0
1:0	Reserved	RO	Reserved.	

1. 17E2 bits 4:0 are for debugging purposes only, not for operational use.

4.4.3 RGMII Control

The following table shows the register settings for the RGMII controls at address 20E2.

Table 59 • RGMII Control, Address 20E2 (0x14)

Bit	Name	Access	Description	Default
15:12	Reserved	RO	Reserved.	
11:8	Reserved	RO	Reserved.	
7	RGMII RXD bit reversal	R/W	Sticky bit. When set to 1, makes the following reversed mapping internally: RXD3 maps to RXD0 RXD2 maps to RXD1 RXD1 maps to RXD2 RXD0 maps to RXD3	0
6:4	RX_CLK delay	R/W	Sticky bit. 000: 0.2 ns delay. 001: 0.8 ns delay. 010: 1.1 ns delay. 011: 1.7 ns delay. 100: 2.0 ns delay. 101: 2.3 ns delay. 110: 2.6 ns delay. 111: 3.4 ns delay.	000
3	RGMII TXD bit reversal	R/W	Sticky bit. When set to 1, makes the following reversed mapping internally: TXD3 maps to TXD0 TXD2 maps to TXD1 TXD1 maps to TXD2 TXD0 maps to TXD3	0

Table 59 • RGMII Control, Address 20E2 (0x14) (continued)

Bit	Name	Access	Description	Default
2:0	TX_CLK delay	R/W	Sticky bit. 000: 0.2 ns delay. 001: 0.8 ns delay. 010: 1.1 ns delay. 011: 1.7 ns delay. 100: 2.0 ns delay. 101: 2.3 ns delay. 110: 2.6 ns delay. 111: 3.4 ns delay.	000

4.4.4 Wake-on-LAN MAC Address [15:0]

The following table shows the register settings for the Wake-on-LAN MAC address at 21E2.

Table 60 • Wake-on-LAN MAC Address, 21E2 (0x15)

Bit	Name	Access	Description	Default
15:0	WoL MAC address [15:0]	R/W	Sticky bit. WoL MAC address lower two bytes.	0x0000

4.4.5 Wake-on-LAN MAC Address [31:16]

The following table shows the register settings for the Wake-on-LAN MAC address at 22E2.

Table 61 • Wake-on-LAN MAC Address, 22E2 (0x16)

Bit	Name	Access	Description	Default
15:0	WoL MAC address [31:16]	R/W	Sticky bit. WoL MAC address middle two bytes.	0x0000

4.4.6 Wake-on-LAN MAC Address [47:32]

The following table shows the register settings for the Wake-on-LAN MAC address at 23E2.

Table 62 • Wake-on-LAN MAC Address, 23E2 (0x17)

Bit	Name	Access	Description	Default
15:0	WoL MAC address [47:32]	R/W	Sticky bit. WoL MAC address upper two bytes.	0x0000

4.4.7 Secure-On Password [15:0]

The following table shows the register settings for the Secure-On password used for WoL at 24E2.

Table 63 • Secure-On Password, 24E2 (0x18)

Bit	Name	Access	Description	Default
15:0	Secure-On password [15:0]	R/W	Sticky bit. Secure-On password for WoL lower two bytes.	0x0000

4.4.8 Secure-On Password [31:16]

The following table shows the register settings for the Secure-On password used for WoL at 25E2.

Table 64 • Secure-On Password, 25E2 (0x19)

Bit	Name	Access	Description	Default
15:0	Secure-On password [31:16]	R/W	Sticky bit. Secure-On password for WoL middle two bytes.	0x0000

4.4.9 Secure-On Password [47:32]

The following table shows the register settings for the Secure-On password used for WoL at 26E2.

Table 65 • Secure-On Password, 26E2 (0x1A)

Bit	Name	Access	Description	Default
15:0	Secure-On password [47:32]	R/W	Sticky bit. Secure-On password for WoL upper two bytes.	0x0000

4.4.10 Wake-on-LAN and MAC Interface Control

The following table shows the register settings for the Wake-on-LAN and MAC interface control at address 27E2.

Table 66 • WoL and MAC Interface Control, Address 27E2 (0x1B)

Bit	Name	Access	Description	Default
15	Secure-On enable	R/W	Sticky bit. 0: Disabled. 1: Enabled.	0
14	Secure-On password length	R/W	Sticky bit. 0: 6 byte password. 1: 4 byte password.	0
13:12	Reserved	RO	Reserved.	
11:8	Address repetition count in Magic packet	R/W	Sticky bit. Count value: 0000: 1 0001: 2 0010: 3 0011: 4 0100: 5 0101: 6 0110: 7 0111: 8 1000: 9 1001: 10 1010: 11 1011: 12 1100: 13 1101: 14 1110: 15 1111: 16	1111

Table 66 • WoL and MAC Interface Control, Address 27E2 (0x1B) (continued)

Bit	Name	Access	Description	Default
7:5	Pad edge rate control	R/W	Sticky bit. MAC interface edge rate control. 000: Slowest edge rate 001: +1 pad edge rate 010: +2 pad edge rate 011: +3 pad edge rate 100: +4 pad edge rate 101: +5 pad edge rate 110: +6 pad edge rate 111: +7 pad edge rate (fastest)	111
4	RMII CLKOUT enable	R/W	Sticky bit. 0: RMII CLKOUT disabled. 1: RMII CLKOUT enabled.	1
3:1	Reserved	RO	Reserved.	
0	MDINT CMOS drive	R/W	Sticky bit. 0: Disabled. 1: Enabled.	0

4.4.11 Extended Interrupt Mask

The following table shows the register settings for the extended interrupt mask at address 28E2.

Table 67 • Extended Interrupt Mask, Address 28E2 (0x1C)

Bit	Name	Access	Description	Default
15:14	Reserved interrupt mask	R/W	Reserved.	00
13	Rx FIFO overflow/underflow interrupt mask	R/W	Sticky bit. 1: Enabled.	0
12	Tx FIFO overflow/underflow interrupt mask	R/W	Sticky bit. 1: Enabled.	0
11:4	Reserved interrupt mask	R/W	Reserved.	0x00
3	EEE link fail interrupt mask	R/W	Sticky bit. 1: Enabled.	0
2	EEE Rx TQ timer interrupt mask	R/W	Sticky bit. 1: Enabled.	0
1	EEE wait quiet/Rx TS timer interrupt mask	R/W	Sticky bit. 1: Enabled.	0
0	EEE wake error interrupt mask	R/W	Sticky bit. 1: Enabled.	0

4.4.12 Extended Interrupt Status

The following table shows the register settings for the extended interrupt status at address 29E2.

Table 68 • Extended Interrupt Status, Address 29E2 (0x1D)

Bit	Name	Access	Description	Default
15:14	Reserved	RO	Reserved.	
13	Rx FIFO overflow/underflow interrupt status	RO	Self-clearing bit. 1: Interrupt pending.	0
12	Tx FIFO overflow/underflow interrupt status	RO	Self-clearing bit. 1: Interrupt pending.	0
11:4	Reserved	RO	Reserved.	

Table 68 • Extended Interrupt Status, Address 29E2 (0x1D) (continued)

Bit	Name	Access	Description	Default
3	EEE link fail interrupt status	RO	Self-clearing bit. 1: Interrupt pending.	0
2	EEE Rx TQ timer interrupt status	RO	Self-clearing bit. 1: Interrupt pending.	0
1	EEE wait quiet/Rx TS timer interrupt status	RO	Self-clearing bit. 1: Interrupt pending.	0
0	EEE wake error interrupt mask	RO	Self-clearing bit. 1: Interrupt pending.	0

4.5 General Purpose Registers

Accessing the general purpose register space is similar to accessing the extended page registers. Set register 31 to 0x0010. This sets all 32 registers to the general purpose register space.

To restore main register page access, write 0x0000 to register 31. All general purpose register bits are super-sticky.

Table 69 • General Purpose Registers Space

Address	Name
0G–12G	Reserved
13G	CLKOUT Control
14G	GPIO Control 2
15G–24G	Reserved
25G	Enhanced LED Control
26G–30G	Reserved

4.5.1 CLKOUT Control

The CLKOUT control register configures the functionality of the CLKOUT output pin.

Table 70 • CLKOUT Control, Address 13G (0x0D)

Bit	Name	Access	Description	Default
15	CLKOUT enable	R/W	1: CLKOUT enabled. 0: CLKOUT disabled.	0
14:13	CLKOUT frequency select	R/W	00: 25 MHz. 01: 50 MHz. 10: 125 MHz. 11: Reserved.	00
12:0	Reserved	R/W	Reserved.	0x0000

4.5.2 GPIO Control 2

The GPIO control 2 register configures the functionality of the LED pins.

Table 71 • GPIO Control 2, Address 14G (0x0E)

Bit	Name	Access	Description	Default
15:10	Reserved	R/W	Reserved.	0x00

Table 71 • GPIO Control 2, Address 14G (0x0E) (continued)

Bit	Name	Access	Description	Default
9	Tri-state enable for LEDs	R/W	1: Tri-state LED output signals instead of driving them high. This allows the signals to be pulled above V_{DDIO} using an external pull-up resistor. 0: Drive LED bus output signals to high and low values.	1
8:0	Reserved	RO	Reserved.	

4.5.3 Enhanced LED Control

Register 25G in the extended register space controls the advanced functionality of the parallel LED signals.

Table 72 • Enhanced LED Control, Address 25G (0x19)

Bit	Name	Access	Description	Default
15:8	LED pulsing duty cycle control	R/W	Programmable control for LED pulsing duty cycle when bit 30.12 is set to 1. Valid settings are between 0 and 198. A setting of 0 corresponds to a 0.5% duty cycle and 198 corresponds to a 99.5% duty cycle. Intermediate values change the duty cycle in 0.5% increments.	0x00
7:0	Reserved	RO	Reserved.	

4.6 Clause 45 Registers to Support Energy-Efficient Ethernet and 802.3bf

This section describes the Clause 45 registers that are required to support energy-efficient Ethernet. Access to these registers is through the IEEE standard registers 13 and 14 (MMD access control and MMD data or address registers).

The following table lists the addresses and register names in the Clause 45 register page space. When the link is down, 0 is the value returned for the x.180x addresses.

Table 73 • Clause 45 Registers Page Space

Address	Name
1.1	PMA/PMD status 1
1.1800	PMA/PMD time sync capable
1.1801	PMA/PMD delay Tx max.
1.1803	PMA/PMD delay Tx min.
1.1805	PMA/PMD delay Rx max.
1.1807	PMA/PMD delay Rx min.
3.1	PCS status 1
3.20	EEE capability
3.22	EEE wake error counter
7.60	EEE advertisement
7.61	EEE link partner advertisement

4.6.1 PMA/PMD Status 1

The following table shows the bit descriptions for the PMA/PMD Status 1 register.

Table 74 • PMA/PMD Status 1

Bit	Name	Access	Description
15:3	Reserved	RO	Reserved.
2	PMD/PMA receive link status	RO/LL	1: PMA/PMD receive link up. 0: PMA/PMD receive link down.
1:0	Reserved	RO	Reserved.

4.6.2 PCS Status 1

The bits in the PCS Status 1 register provide a status of the EEE operation from the PCS for the link that is currently active.

Table 75 • PCS Status 1, Address 3.1

Bit	Name	Access	Description
15:12	Reserved	RO	Reserved.
11	Tx LPI received	RO/LH	1: Tx PCS has received LPI. 0: LPI not received.
10	Rx LPI received	RO/LH	1: Rx PCS has received LPI. 0: LPI not received.
9	Tx LPI indication	RO	1: Tx PCS is currently receiving LPI. 0: PCS is not currently receiving LPI.
8	Rx LPI indication	RO	1: Rx PCS is currently receiving LPI. 0: PCS is not currently receiving LPI.
7:3	Reserved	RO	Reserved.
2	PCS receive link status	RO/LL	1: PCS receive link up. 0: PCS receive link down.
1:0	Reserved	RO	Reserved.

4.6.3 EEE Capability

This register is used to indicate the capability of the PCS to support EEE functions for each PHY type. The following table shows the bit assignments for the EEE capability register.

Table 76 • EEE Capability, Address 3.20

Bit	Name	Access	Description
15:2	Reserved	RO	Reserved.
1	100BASE-TX EEE	RO	1: EEE is supported for 100BASE-TX. 0: EEE is not supported for 100BASE-TX.
0	Reserved	RO	Reserved.

4.6.4 EEE Wake Error Counter

This register is used by PHY types that support EEE to count wake time faults where the PHY fails to complete its normal wake sequence within the time required for the specific PHY type. The definition of the fault event to be counted is defined for each PHY and can occur during a refresh or a wakeup as

defined by the PHY. This 16-bit counter is reset to all zeros when the EEE wake error counter is read or when the PHY undergoes hardware or software reset.

Table 77 • EEE Wake Error Counter, Address 3.22

Bit	Name	Access	Description
15:0	Wake error counter	RO	Count of wake time faults for a PHY

4.6.5 EEE Advertisement

This register defines the EEE advertisement that is sent in the unformatted next page following a EEE technology message code. The following table shows the bit assignments for the EEE advertisement register.

Table 78 • EEE Advertisement, Address 7.60

Bit	Name	Access	Description	Default
15:2	Reserved	RO	Reserved.	
1	100BASE-TX EEE	R/W	1: Advertise that the 100BASE-TX has EEE capability. 0: Do not advertise that the 100BASE-TX has EEE capability.	0
0	Reserved	RO	Reserved.	

4.6.6 EEE Link Partner Advertisement

All the bits in the EEE LP advertisement register are read only. A write to the EEE LP advertisement register has no effect. When the AN process has been completed, this register will reflect the contents of the link partner's EEE advertisement register. The following table shows the bit assignments for the EEE advertisement register.

Table 79 • EEE Advertisement, Address 7.61

Bit	Name	Access	Description
15:2	Reserved	RO	Reserved.
1	100BASE-TX EEE	RO	1: Link partner is advertising EEE capability for 100BASE-TX. 0: Link partner is not advertising EEE capability for 100BASE-TX.
0	Reserved	RO	Reserved.

4.6.7 802.3bf Registers

The following table shows the bit assignments for the 802.3bf registers. When the link is down, 0 is the value returned. 1.1801 would be device address of 1 and register address of 1801.

Table 80 • 802.3bf Registers

Register	Name	Function
1.1800	PMA/PMD Time Sync capable	1: PMA/PMD Time Sync Tx capable. 0: PMA/PMD Time Sync Rx capable.
1.1801	PMA/PMD delay Tx max	Tx maximum delay through PHY (PMA/PMD/PCS).
1.1803	PMA/PMD delay Tx min	Tx minimum delay through PHY (PMA/PMD/PCS).
1.1805	PMA/PMD delay Rx max	Rx maximum delay through PHY (PMA/PMD/PCS).
1.1807	PMA/PMD delay Rx min	Rx minimum delay through PHY (PMA/PMD/PCS).

5 Electrical Specifications

This section provides the DC characteristics, AC characteristics, recommended operating conditions, and stress ratings for the VSC8530-04 device.

5.1 DC Characteristics

This section contains the DC specifications for the VSC8530-04 device.

5.1.1 VDDMAC, VDDIO, and VDDMDIO (2.5 V)

The following table shows the DC specifications for the pins referenced to VDDMAC, VDDIO, and VDDMDIO when it is set to 2.5 V. The specifications listed in the following table are valid only when VDD1 = 1.0 V, VDD1A = 1.0 V, and VDD25A = 2.5 V.

Table 81 • VDDMAC, VDDIO, and VDDMDIO (2.5 V) DC Characteristics

Parameter	Symbol	Minimum	Typical	Maximum	Unit	Condition
Output high voltage	V_{OH}	2.0			V	$I_{OH} = -1.0$ mA
Output low voltage	V_{OL}			0.4	V	$I_{OL} = 1.0$ mA
Input high voltage	V_{IH}	1.85		3.6	V	
Input high voltage	V_{IH}	1.85		3.1	V	SMI pins (MDC, MDIO)
Input high voltage	V_{IH}	1.85		2.75	V	VDDMAC-referenced pins
Input low voltage	V_{IL}	-0.3		0.7	V	
Input leakage current	I_{ILEAK}	-85		85	μ A	Internal resistor included
Output leakage current	I_{OLEAK}	-85		85	μ A	Internal resistor included

5.1.2 VDDMAC, VDDIO, and VDDMDIO (3.3 V)

The following table shows the DC specifications for the pins referenced to VDDMAC, VDDIO, and VDDMDIO when it is set to 3.3 V. The specifications listed in the following table are valid only when VDD1 = 1.0 V, VDD1A = 1.0 V, and VDD25A = 2.5 V.

Table 82 • VDDMAC, VDDIO, and VDDMDIO (3.3 V) DC Characteristics

Parameter	Symbol	Minimum	Typical	Maximum	Unit	Condition
Output high voltage	V_{OH}	2.6			V	$I_{OH} = -1.0$ mA
Output low voltage	V_{OL}			0.4	V	$I_{OL} = 1.0$ mA
Input high voltage	V_{IH}	2.25		3.6	V	
Input low voltage	V_{IL}	-0.3		0.8	V	
Input leakage current	I_{ILEAK}	-135		135	μ A	Internal resistor included
Output leakage current	I_{OLEAK}	-135		135	μ A	Internal resistor included

5.1.3 VDDMAC and VDDMDIO (1.5 V)

The following table shows the DC specifications for the pins referenced to VDDMAC and VDDMDIO when it is set to 1.5 V. The specifications listed in the following table are valid only when VDD1 = 1.0 V, VDD1A = 1.0 V, VDD25A = 2.5 V, and VDDIO = 2.5 V or 3.3 V.

Table 83 • VDDMAC and VDDMDIO DC Characteristics (1.5 V)

Parameter	Symbol	Minimum	Typical	Maximum	Unit	Condition
Output high voltage	V_{OH}	1.2			V	$I_{OH} = -1$ mA
Output low voltage	V_{OL}			0.25	V	$I_{OL} = 1$ mA
Input high voltage	V_{IH}	1.13		1.87	V	VDDMDIO-referenced pins
Input high voltage	V_{IH}	1.13		1.65	V	VDDMAC-referenced pins
Input low voltage	V_{IL}	-0.375		0.45	V	
Input leakage current	I_{ILEAK}	-40		40	μ A	Internal resistor included
Output leakage current	I_{OLEAK}	-40		40	μ A	Internal resistor included

5.1.4 VDDMAC and VDDMDIO (1.8 V)

The following table shows the DC specifications for the pins references to VDDMAC and VDDMDIO when it is set to 1.8 V. The specifications listed in the following table are valid only when VDD1 = 1.0 V, VDD1A = 1.0 V, VDD25A = 2.5 V, and VDDIO = 2.5 V or 3.3 V.

Table 84 • VDDMAC and VDDMDIO DC Characteristics (1.8 V)

Parameter	Symbol	Minimum	Typical	Maximum	Unit	Condition
Output high voltage	V_{OH}	1.43			V	$I_{OH} = -1$ mA
Output low voltage	V_{OL}			0.3	V	$I_{OL} = 1$ mA
Input high voltage	V_{IH}	1.35		2.25	V	VDDMDIO-referenced pins
Input high voltage	V_{IH}	1.35		1.98	V	VDDMAC-referenced pins
Input low voltage	V_{IL}	-0.45		0.54	V	
Input leakage current	I_{ILEAK}	-48		48	μ A	Internal resistor included
Output leakage current	I_{OLEAK}	-48		48	μ A	Internal resistor included

5.1.5 VDDMDIO (1.2 V)

The following table shows the DC specifications for the pins referenced to VDDMDIO when it is set to 1.2 V. The specifications listed in the following table are valid only when VDD1 = 1.0 V, VDD1A = 1.0 V, and VDD25A = 2.5 V.

Table 85 • VDDMDIO DC Characteristics

Parameter	Symbol	Minimum	Typical	Maximum	Unit	Condition
Output high voltage	V_{OH}	0.95			V	$I_{OH} = -1$ mA
Output low voltage	V_{OL}			0.2	V	$I_{OL} = 1$ mA
Input high voltage	V_{IH}	0.9		1.5	V	
Input low voltage	V_{IL}	-0.3		0.36	V	

Table 85 • VDDMDIO DC Characteristics (continued)

Parameter	Symbol	Minimum	Typical	Maximum	Unit	Condition
Input leakage current	I_{ILEAK}	-32		32	μA	Internal resistor included
Output leakage current	I_{OLEAK}	-32		32	μA	Internal resistor included

5.1.6 XTAL1

The following table shows the DC specifications for the XTAL1 pin referenced to VDD25A. The specifications listed in the following table are valid only when VDD1 = 1.0 V, VDD1A = 1.0 V, and the on-chip oscillator is turned off.

Table 86 • XTAL1 DC Characteristics

Parameter	Symbol	Minimum	Typical	Maximum	Unit
Input high voltage	V_{IH}	1.85		2.75	V
Input low voltage	V_{IL}	-0.3		0.7	V
Input leakage current	I_{ILEAK}	-85		85	μA
Output leakage current	I_{OLEAK}	-85		85	μA

5.1.7 LED

The following table shows the DC specifications for the LED pins.

Table 87 • LED DC Characteristics

Parameter	Symbol	Minimum	Typical	Maximum	Unit
Output high current drive strength	I_{OH}			-24	mA
Output low current drive strength	I_{OL}	24			mA

5.1.8 Internal Pull-Up or Pull-Down Resistors

Internal pull-up or pull-down resistors are specified in the following table. All internal pull-up resistors are connected to their respective I/O supply.

Table 88 • Internal Pull-Up or Pull-Down Resistors (RGMII/RMII Interface)

Parameter	Symbol	Minimum	Typical	Maximum	Unit	Condition
Internal pull-down resistor	R_{PD}	31	46	72	$k\Omega$	3.3 V
Internal pull-down resistor	R_{PD}	38	59	96	$k\Omega$	2.5 V
Internal pull-down resistor	R_{PD}	57	91	155	$k\Omega$	1.8 V
Internal pull-down resistor	R_{PD}	78	125	220	$k\Omega$	1.5 V

Table 89 • Internal Pull-Up or Pull-Down Resistors (Other I/Os)

Parameter	Symbol	Minimum	Typical	Maximum	Unit	Condition
Internal pull-up resistor	R_{PU}	26	39	64	$k\Omega$	3.3 V
Internal pull-down resistor	R_{PD}	26	45	79	$k\Omega$	3.3 V
Internal pull-up resistor	R_{PU}	33	53	93	$k\Omega$	2.5 V
Internal pull-down resistor	R_{PD}	34	58	108	$k\Omega$	2.5 V

5.1.9 Current Consumption

The following table shows the measured current consumption values for each mode of operation. Add values from table for VDDMAC current consumption to calculate total typical current for each power supply. Add significant margin above the values for sizing power supplies.

Note: VDDMAC currents at 1.5 V and 1.8 V are measured with an edge rate setting of 111. Currents at 2.5 V and 3.3 V are measured with an edge rate setting of 100.

Table 90 • Current Consumption

Mode	Typical (mA)			
	VDD1	VDD1A	VDD25A	VDDIO/VDDMDIO
Reset	15	5	5	5
Power Down	20	20	15	5
ActiPHY	20	20	20	5
No Link	30	20	55	5
100BASE-TX	35	20	100	5
10BASE-T	20	20	65	5
100BASE-TX EEE	25	20	60	5
10BASE-Te	20	20	60	5

Table 91 • Current Consumption (VDDMAC)

Mode	Typical (mA)			
	1.5 V	1.8 V	2.5 V	3.3 V
Reset	5	5	5	5
Power Down	10	10	15	20
ActiPHY	10	10	15	20
No Link	10	10	15	20
RGMII (100BASE-TX)	5	10	10	15
RGMII (10BASE-T/Te)	5	5	5	5
RMII (100BASE-TX)	10	15	15	20
RMII (10BASE-T/Te)	10	10	15	15

Table 92 • Power Consumption

Parameter	Symbol	Typical	Maximum	Unit
Worst-case power consumption	P_D		580	mW

5.2 AC Characteristics

This section provides the AC specifications for the VSC8530-04 device.

5.2.1 Reference Clock

The following table lists the AC specifications for the REFCLK reference clock.

Table 93 • RefClk

Parameter	Symbol	Minimum	Typical	Maximum	Unit	Condition
REFCLK frequency, REFCLK_SEL[1:0]= 11	f	-100 ppm	125	100 ppm	MHz	
REFCLK frequency, REFCLK_SEL[1:0]= 10	f	-100 ppm	50	100 ppm	MHz	
REFCLK frequency, REFCLK_SEL[1:0]= 01	f	-100 ppm	25	100 ppm	MHz	
Rise time and fall time	t_R, t_F			1.5	ns	20% to 80%, 5.1 pF load
Duty cycle		45		55	%	
Phase jitter—Gaussian				4	ps _{RMS}	Bandwidth from 10 kHz to 10 MHz
Total jitter, peak-to-peak				200	ps _{PP}	10K samples.

5.2.1.1 XTAL Reference Clock

When using the 25 MHz crystal clock input option (REFCLK_SEL[1:0] = 00), the additional specifications listed in the following table are required.

Table 94 • XTAL RefClk

Parameter	Symbol	Minimum	Typical	Maximum	Unit
CL ¹		8			pF
Crystal ESR				60	Ω

$$1. \quad CL = \frac{C1_{EXT} \times C2_{EXT}}{C1_{EXT} + C2_{EXT}}$$

where

$$C1_{EXT} = C1 + C1N_{EXT}$$

$$C2_{EXT} = C2 + C2O_{EXT}$$

$C1N_{EXT}$ represents input (XTAL1) I/O, bond pad, package pin, and routing parasitic capacitance

and $C2O_{EXT}$ represents output (XTAL2) I/O, bond pad, package pin, and routing parasitic capacitance.

For a reference tank circuit, see [Figure 9](#), page 12.

The following illustration shows the test circuit for the CLKOUT, RCVRD_CLK, and RMII_CLKOUT outputs.

Figure 21 • Test Circuit for Clock Output Signal

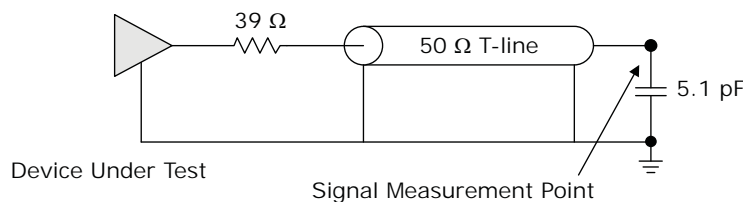

5.2.2 CLKOUT

This section provides the AC characteristics for the CLKOUT signal.

The following table shows the AC specifications for the CLKOUT output.

Table 95 • CLKOUT AC Characteristics

Parameter	Symbol	Minimum	Typical	Maximum	Unit	Condition
CLKOUT frequency	f		125		MHz	
CLKOUT frequency	f		50		MHz	
CLKOUT frequency	f		25		MHz	
CLKOUT cycle time	t_{COCYC}		8		ns	
CLKOUT cycle time	t_{COCYC}		20		ns	
CLKOUT cycle time	t_{COCYC}		40		ns	
Frequency stability	$f_{\text{STABILITY}}$			5	ppm	Relative to device REFCLK frequency
Duty cycle	DC	40	50	60	%	CLKOUT at 25 MHz and 125 MHz
Duty cycle	DC	35	50	75	%	CLKOUT at 50 MHz
Clock rise time and fall time	$t_{\text{R}}, t_{\text{F}}$			1.5	ns	20% to 80%
Peak-to-peak jitter	$J_{\text{PP_CLKOUT}}$			700	ps	10 k samples

5.2.3 RMII_CLKOUT

This section provides the AC characteristics for the RMII_CLKOUT signal.

Note: The RMII_CLKOUT signal is provided on the RX_CLK pin (see Table 3, page 5) when the device is operating in RMII mode.

The following table shows the AC specifications for RMII_CLKOUT.

Table 96 • RMII_CLKOUT AC Characteristics

Parameter	Symbol	Minimum	Typical	Maximum	Unit
RMII_CLKOUT frequency	f		50		MHz
RMII_CLKOUT duty cycle	DC	35		65	%
RMII_CLKOUT rise time	t_{R}			1	ns
RMII_CLKOUT fall time	t_{F}			1	ns

5.2.4 Basic Serial LEDs

This section contains the AC specifications for the basic serial LEDs.

Table 97 • Basic Serial LEDs AC Characteristics

Parameter	Symbol	Typical	Unit
LED_CLK cycle time	t_{CYC}	1024	ns
Pause between LED port sequences	$t_{\text{PAUSE_PORT}}$	3072	ns
Pause between LED bit sequences	$t_{\text{PAUSE_BIT}}$	25.541632	ms
LED_CLK to LED_DATA	t_{CO}	1	ns

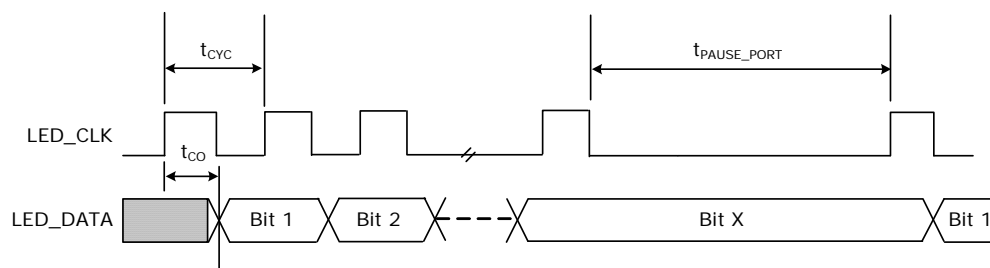
Figure 22 • Basic Serial LED Timing

5.2.5 RMII AC Characteristics

The following table lists the characteristics when using the device in RMII mode.

Table 98 • RMII AC Characteristics

Parameter	Symbol	Minimum	Typical	Maximum	Unit
TXD[1:0], TX_EN,RXD[1:0], CRS_DV, RX_ER data setup to RMII_CLKIN rising edge	T_{SU}	4			ns
TXD[1:0], TX_EN,RXD[1:0], CRS_DV, RX_ER data hold from RMII_CLKIN rising edge	T_{HOLD}	2			ns

5.2.6 Uncompensated RGMII

The following table lists the characteristics when using the device in RGMII uncompensated mode. For more information about the RGMII uncompensated timing, see [Figure 23](#), page 61.

Table 99 • Uncompensated RGMII AC Characteristics

Parameter	Symbol	Minimum	Typical	Maximum	Unit	Condition
Clock frequency	f_{CLK}		25 2.5		MHz	100BASE-TX operation 10BASE-T operation
Duty cycle	DC	40	50	60	%	
Data to clock output skew (at Transmitter) ¹	t_{SKEWT}	-500		500	ps	
Data to clock output skew (at Receiver) ¹	t_{SKEWR}	1	1.8	2.6	ns	
TX_CLK switching threshold	V_{THRESH}		0.75 0.90 1.25 1.65		V	VDDMAC = 1.5 V VDDMAC = 1.8 V VDDMAC = 2.5 V VDDMAC = 3.3 V

Table 99 • Uncompensated RGMII AC Characteristics (continued)

Parameter	Symbol	Minimum	Typical	Maximum	Unit	Condition
Clock/data output rise and fall times	t_R, t_F			0.75	ns	$V_{DDMAC} = 1.5\text{ V}$, $27E2.7:5 = 111$
						$V_{DDMAC} = 1.8\text{ V}$, $27E2.7:5 = 111$
						$V_{DDMAC} = 2.5\text{ V}$, $27E2.7:5 = 100$
						$V_{DDMAC} = 3.3\text{ V}$, $27E2.7:5 = 100$

- When operating in uncompensated mode, the PC board design requires a clock to be routed such that an additional trace delay of greater than 1.5 ns is added to the associated clock signal.

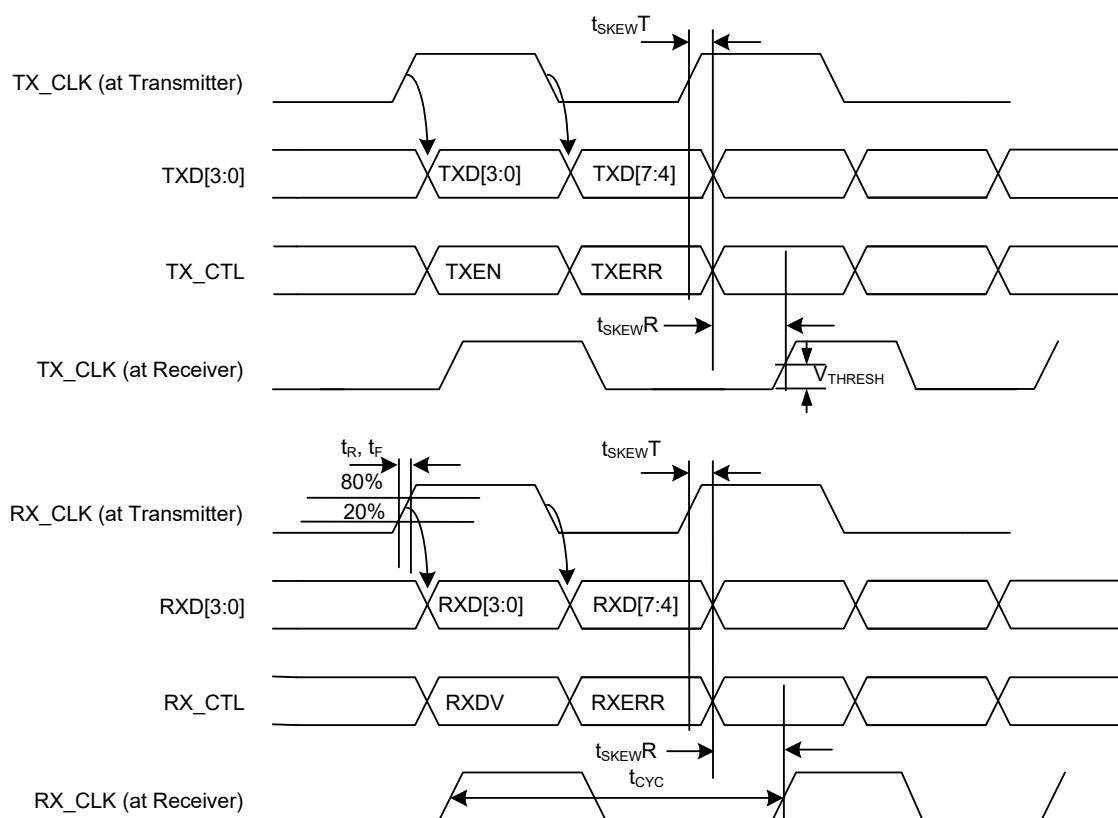
Figure 23 • Uncompensated RGMII Timing

5.2.7 Compensated RGMII

The following table lists the characteristics when using the device in RGMII compensated mode.

Table 100 • PHY Input (GTX_CLK Delay When Register 20E2.[2:0]=011'b)

Parameter	Symbol	Minimum	Typical	Maximum	Unit
Data to clock setup (TX_CLK delay = 011'b)	t_{SETUP_T}	-1.0			ns
Clock to data hold (TX_CLK delay = 011'b)	t_{HOLD_T}	2.8			ns

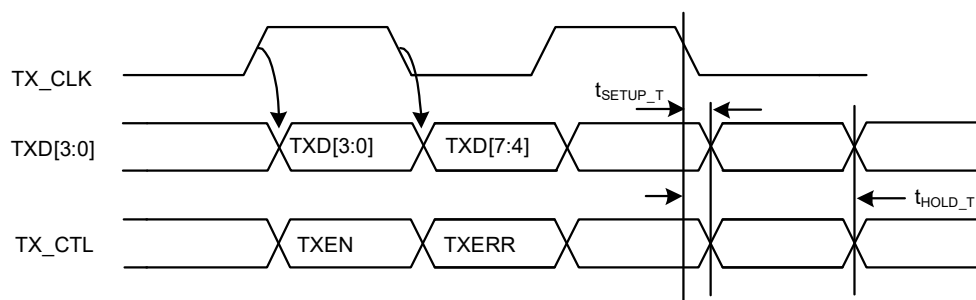
Figure 24 • Compensated Input RGMII Timing**Table 101 • PHY Output (RX_CLK Delay When Register 20E2.[6:4]=100'b)**

Parameter	Symbol	Minimum	Typical	Maximum	Unit
Data to clock setup (RX_CLK delay = 100'b)	t_{SETUP_R}	1.4	2.0		ns
Clock to data hold (RX_CLK delay = 100'b)	t_{HOLD_R}	1.5	2.0		ns

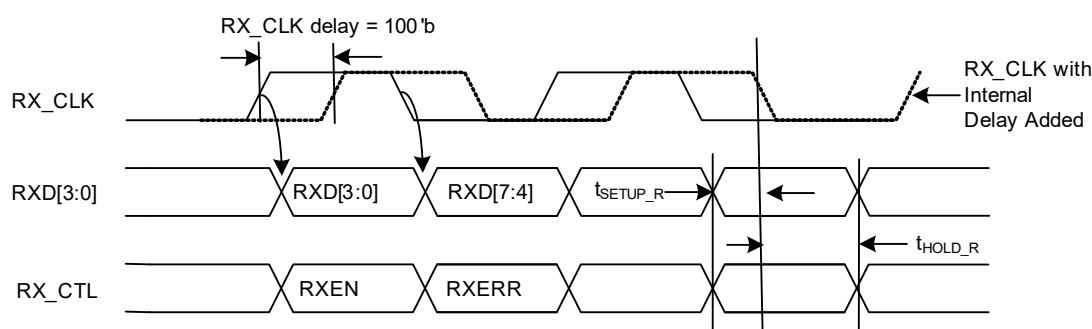
Figure 25 • Compensated Output RGMII Timing

5.2.8 Serial Management Interface

This section contains the AC specifications for the serial management interface (SMI).

Table 102 • Serial Management Interface AC Characteristics

Parameter	Symbol	Minimum	Typical	Maximum	Unit	Condition
MDC frequency ¹	f_{CLK}		2.5	12.5	MHz	
MDC cycle time	t_{CYC}	80	400		ns	
MDC time high	t_{WH}	20	50		ns	
MDC time low	t_{WL}	20	50		ns	
Setup to MDC rising	t_{SU}	10			ns	
Hold from MDC rising	t_{H}	14			ns	
MDC rise time	t_{R}			100 $t_{\text{CYC}} \times 10\%1$	ns	$f_{\text{CLK}} < 1$ MHz f_{CLK} from 1 MHz to 12.5 MHz
MDC fall time	t_{F}			100 $t_{\text{CYC}} \times 10\%1$	ns	$f_{\text{CLK}} < 1$ MHz f_{CLK} from 1 MHz to 12.5 MHz

Table 102 • Serial Management Interface AC Characteristics (continued)

Parameter	Symbol	Minimum	Typical	Maximum	Unit	Condition
MDC to MDIO valid	t_{CO}		10	300	ns	Time-dependent on the value of the external pull-up resistor on the MDIO pin

- For f_{CLK} above 1 MHz, the maximum rise time and fall time is in relation to the frequency of the MDC clock period. For example, if f_{CLK} is 2 MHz, the maximum clock rise time and fall time is 50 ns.

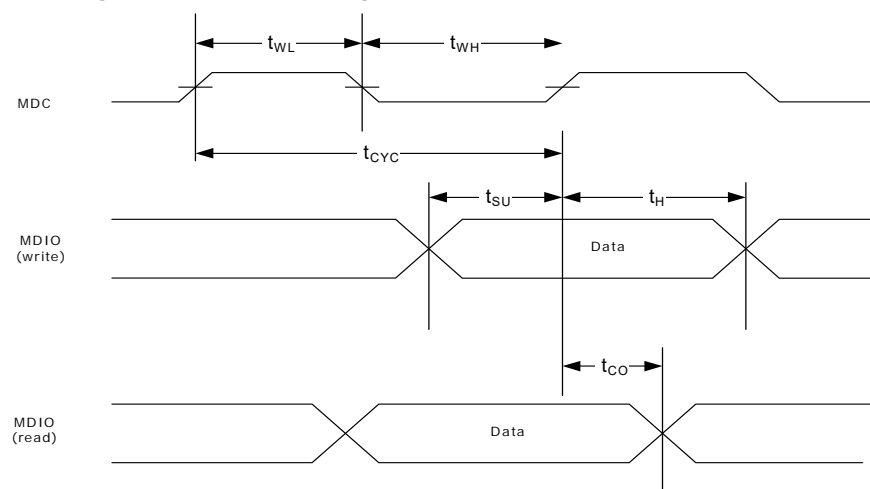
Figure 26 • Serial Management Interface Timing

5.2.9 Reset Timing

This section contains the AC specifications that apply to device reset functionality. The signal applied to the NRESET input must comply with the specifications listed in the following table.

Table 103 • Reset Timing AC Characteristics

Parameter	Symbol	Minimum	Typical	Maximum	Unit
NRESET assertion time after power supplies and clock stabilize	t_W	2			ms
Recovery time from reset inactive to device fully active	t_{REC}		15		ms
NRESET pulse width	$t_{W(RL)}$	100			ns
Wait time between NRESET de-assert and access of the SMI interface	t_{WAIT}	15			ms

5.3 Operating Conditions

The following table shows the recommended operating conditions for the VSC8530-04 device.

Table 104 • Recommended Operating Conditions

Parameter	Symbol	Minimum	Typical	Maximum	Unit
Power supply voltage for core supply	V_{DD1}	0.95	1.00	1.05	V
Power supply voltage for analog circuits	V_{DD1A}	0.95	1.00	1.05	V
2.5 V power supply voltage for analog circuits	V_{DD25A}	2.38	2.5	2.62	V
2.5 V power supply voltage for VDDMAC, VDDIO, and VDDMDIO	V_{25}	2.38	2.5	2.62	V

Table 104 • Recommended Operating Conditions (continued)

Parameter	Symbol	Minimum	Typical	Maximum	Unit
3.3 V power supply voltage for VDDMAC, VDDIO, and VDDMDIO	V ₃₃	3.135	3.3	3.465	V
1.8 V power supply voltage for VDDMAC and VDDMDIO	V ₁₈	1.71	1.8	1.89	V
1.5 V power supply voltage for VDDMAC and VDDMDIO	V ₁₅	1.425	1.5	1.575	V
1.2 V power supply voltage for VDDMDIO	V ₁₂	1.14	1.2	1.26	V
VSC8530-04 operating temperature ¹	T	−40		125	°C

1. Minimum specification is ambient temperature, and the maximum is junction temperature.

5.4 Stress Ratings

This section contains the stress ratings for the VSC8530-04 device.

Warning Stresses listed in the following table may be applied to devices one at a time without causing permanent damage. Functionality at or exceeding the values listed is not implied. Exposure to these values for extended periods may affect device reliability.

Table 105 • Stress Ratings

Parameter	Symbol	Minimum	Maximum	Unit
Power supply voltage for core supply	V _{DD1}	−0.3	1.10	V
Power supply voltage for analog circuits	V _{DD1A}	−0.3	1.10	V
Power supply voltage for analog circuits	V _{DD25A}	−0.3	2.75	V
Power supply voltage for digital I/O	V _{DDMAC} , V _{DDIO} , V _{DDMDIO}	−0.3	3.6	V
Input voltage for digital I/O (3.3 V)			3.6	V
Input voltage for digital I/O (2.5 V)			3.3	V
Storage temperature	T _S	−55	125	°C
Electrostatic discharge voltage, charged device model	V _{ESD_CDM}	−1000	1000	V
Electrostatic discharge voltage, human body model	V _{ESD_HBM}	See note ¹		V

1. This device has completed all required testing as specified in the JEDEC standard JESD22-A114, *Electrostatic Discharge (ESD) Sensitivity Testing Human Body Model (HBM)*, and complies with a Class 2 rating. The definition of Class 2 is any part that passes an ESD pulse of 2000 V, but fails an ESD pulse of 4000 V.

Warning This device can be damaged by electrostatic discharge (ESD) voltage. Microsemi recommends that all integrated circuits be handled with appropriate precautions. Failure to observe proper handling and installation procedures may adversely affect reliability of the device.

6 Pin Descriptions

The VSC8530-04 device has 48 pins, which are described in this section.



The pin information is also provided as an attached Microsoft Excel file so that you can copy it electronically. In Acrobat, double-click the attachment icon.

6.1 Pin Identifications

This section contains the pin descriptions for the VSC8530-04 device. The following table provides notations for definitions of the various pin types.

Table 106 • Pin Type Symbol Definitions

Symbol	Pin Type	Description
A	Analog	Analog.
ADIFF	Analog differential	Analog differential signal pair.
I	Input	Input without on-chip pull-up or pull-down resistor.
I/O	Bidirectional	Bidirectional input or output signal.
O	Output	Output signal.
P	Power	Power.
PD	Pull-down	On-chip pull-down resistor present.
PU	Pull-up	On-chip pull-up resistor present.

6.2 Pin Diagram

The following illustration shows the pin diagram for the VSC8530-04 device, as seen looking through the package from the top of it. Note that the exposed pad connects to the package ground.

Figure 27 • Pin Diagram

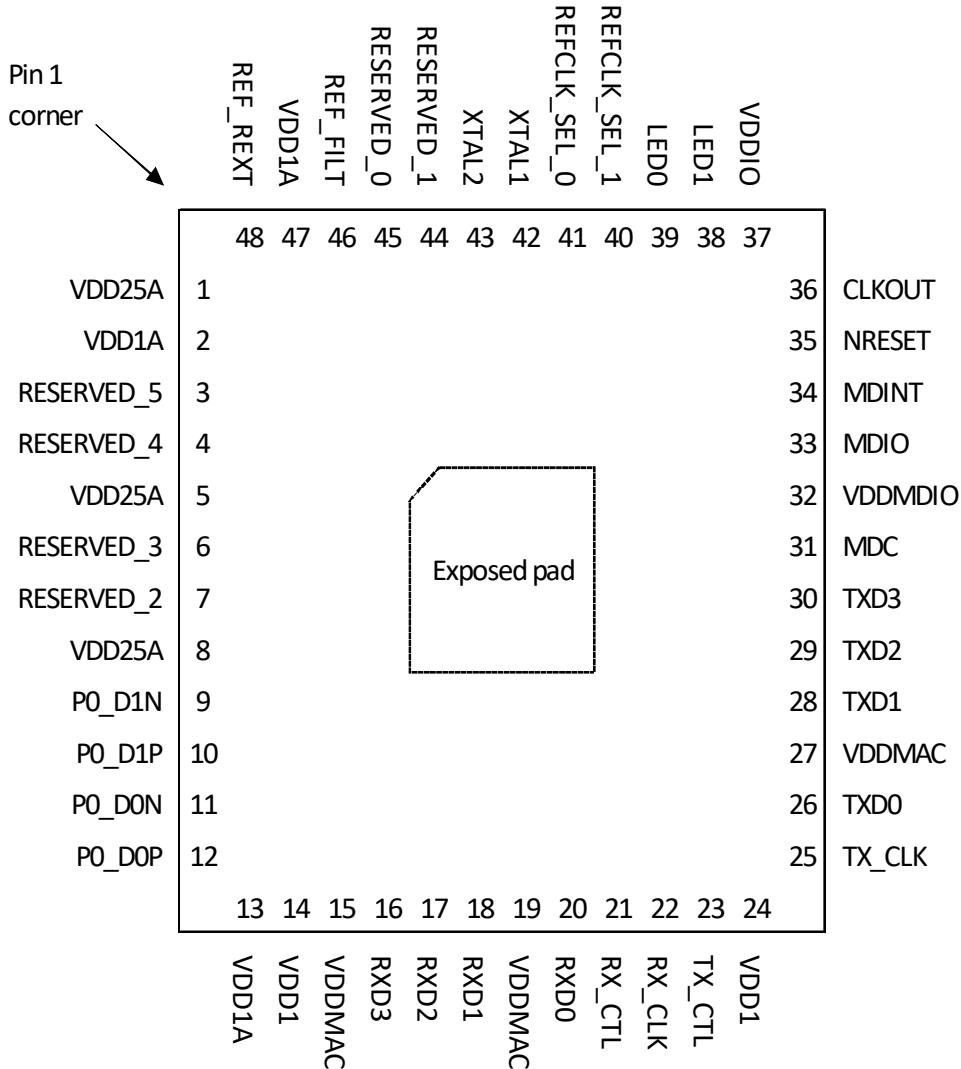

6.3 Pins by Function

This section contains the functional pin descriptions for the VSC8530-04 device. All power supply pins must be connected to their respective voltage input, even if certain functions are not used for a specific application. No power supply sequencing is required. However, clock and power must be stable before releasing Reset. The SMI pins are referenced to VDDMDIO.

Functional Group	Name	Number	Type	I/O Domain	Description
Cu PHY Media	PO_D0N	11	ADIFF	VDD25A	Tx/Rx channel A negative signal
Cu PHY Media	PO_D0P	12	ADIFF	VDD25A	Tx/Rx channel A positive signal
Cu PHY Media	PO_D1N	9	ADIFF	VDD25A	Tx/Rx channel B negative signal

Cu PHY Media	P0_D1P	10	ADIFF	VDD25A	Tx/Rx channel B positive signal
Miscellaneous	REF_FILT	46	A	VDD25A	Reference filter connects to an external 0.01 uF (20%) capacitor to analog ground
Miscellaneous	REF_REXT	48	A	VDD25A	Reference connects to an external 2k Ω (1%) resistor to analog ground
Miscellaneous	RESERVED_0	45		VDD25A	Reserved signal, leave unconnected
Miscellaneous	RESERVED_1	44		VDD25A	Reserved signal, leave unconnected
Miscellaneous	RESERVED_2	7	ADIFF	VDD25A	Internal test signal. Connect a 100 Ω (5%) resistor across this pin and pin 6.
Miscellaneous	RESERVED_3	6	ADIFF	VDD25A	Internal test signal. Connect a 100 Ω (5%) resistor across this pin and pin 7.
Miscellaneous	RESERVED_4	4	ADIFF	VDD25A	Internal test signal. Connect a 100 Ω (5%) resistor across this pin and pin 3.
Miscellaneous	RESERVED_5	3	ADIFF	VDD25A	Internal test signal. Connect a 100 Ω (5%) resistor across this pin and pin 4.
PHY Configuration	CLKOUT	36	I/O, PD	VDDIO	Clock output, can be enabled or disabled. Output a clock based on the local reference clock with programmable frequency. This pin is not active when NRESET is asserted and is disabled by default. When disabled, the pin is held low. The logic state on this pin is latched on the rising edge of NRESET to configure CLKOUT output. See "Hardware Mode Strapping and PHY Addressing" for details.
PHY Configuration	LED0	39	O	VDDIO	LED direct drive outputs. All LED pins are active low. LED_DATA output in serial LED mode.
PHY Configuration	LED1	38	O	VDDIO	LED direct drive outputs. All LED pins are active low. LED_CLK output in serial LED mode.
PHY Configuration	NRESET	35	I, PD	VDDIO	Device reset. Active low input that powers down the device and sets all register bits to their default state.
PHY Configuration	REFCLK_SEL_0	41	I, PU	VDDIO	Reference clock mode/frequency select signal
PHY Configuration	REFCLK_SEL_1	40	I, PU	VDDIO	Reference clock mode/frequency select signal
PHY Configuration	XTAL1	42	I	VDD25A	Crystal/single ended reference clock input
PHY Configuration	XTAL2	43	O	VDD25A	Crystal output, leave unconnected when using single ended reference clock
PWR	VDD1	14	P		1.0 V digital core power
PWR	VDD1	24	P		1.0 V digital core power
PWR	VDD1A	2	P		1.0 V analog power requiring additional PCB power supply filtering
PWR	VDD1A	13	P		1.0 V analog power requiring additional PCB power supply filtering
PWR	VDD1A	47	P		1.0 V analog power requiring additional PCB power supply filtering

PWR	VDD25A	1	P		2.5 V analog power requiring additional PCB power supply filtering
PWR	VDD25A	5	P		2.5 V analog power requiring additional PCB power supply filtering
PWR	VDD25A	8	P		2.5 V analog power requiring additional PCB power supply filtering
PWR	VDDIO	37	P		2.5 V or 3.3 V general I/O power
PWR	VDDMAC	15	P		1.5 V, 1.8 V, 2.5 V, or 3.3 V RGMII/RMII MAC power
PWR	VDDMAC	19	P		1.5 V, 1.8 V, 2.5 V, or 3.3 V RGMII/RMII MAC power
PWR	VDDMAC	27	P		1.5 V, 1.8 V, 2.5 V, or 3.3 V RGMII/RMII MAC power
PWR	VDDMDIO	32	P		1.2 V, 1.5 V, 1.8 V, 2.5 V, or 3.3 V power for SMI pins
RGMII/RMII	RX_CLK	22	I/O, PD	VDDMAC	RGMII receive clock output. The logic state on this pin is latched on the rising edge of NRESET to configure the device. See "Hardware Mode Strapping and PHY Addressing" for details.
RGMII/RMII	RX_CTL	21	I/O, PD	VDDMAC	RGMII receive control output. The logic state on this pin is latched on the rising edge of NRESET to configure the device. See "Hardware Mode Strapping and PHY Addressing" for details.
RGMII/RMII	RXD0	20	I/O, PD	VDDMAC	RGMII data output. The logic state on this pin is latched on the rising edge of NRESET to configure the device. See "Hardware Mode Strapping and PHY Addressing" for details.
RGMII/RMII	RXD1	18	I/O, PD	VDDMAC	RGMII data output. The logic state on this pin is latched on the rising edge of NRESET to configure the device. See "Hardware Mode Strapping and PHY Addressing" for details.
RGMII/RMII	RXD2	17	I/O, PD	VDDMAC	RGMII data output. The logic state on this pin is latched on the rising edge of NRESET to configure the device. See "Hardware Mode Strapping and PHY Addressing" for details.
RGMII/RMII	RXD3	16	I/O, PD	VDDMAC	RGMII data output. The logic state on this pin is latched on the rising edge of NRESET to configure the device. See "Hardware Mode Strapping and PHY Addressing" for details.
RGMII/RMII	TX_CLK	25	I, PD	VDDMAC	RGMII transmit clock input
RGMII/RMII	TX_CTL	23	I, PD	VDDMAC	RGMII transmit data control input
RGMII/RMII	TXD0	26	I, PD	VDDMAC	RGMII data input
RGMII/RMII	TXD1	28	I, PD	VDDMAC	RGMII data input
RGMII/RMII	TXD2	29	I, PD	VDDMAC	RGMII data input
RGMII/RMII	TXD3	30	I, PD	VDDMAC	RGMII data input

SMI	MDC	31	I	VDDMDIO	Management data clock. A 0 MHz to 12.5 MHz reference input is used to clock serial MDIO data into and out of the PHY.
SMI	MDINT	34	O, OD	VDDMDIO	Management interrupt signal. These pins can be tied together in a wired-OR configuration with only a single pull-up resistor.
SMI	MDIO	33	I/O	VDDMDIO	Management data input/output pin. Serial data is written or read from this pin bi-directionally between the PHY and station manager synchronously on the positive edge of MDC. One external pull-up resistor is required at the station manager.

7 Package Information

The VSC8530XMW-04 package is a lead-free (Pb-free), 48-pin, plastic quad flat no-lead (QFN) package with an exposed pad, 6 mm × 6 mm body size, 0.4 mm pin pitch, and 0.9 mm maximum height.

Lead-free products from Microsemi comply with the temperatures and profiles defined in the joint IPC and JEDEC standard IPC/JEDEC J-STD-020. For more information, see the IPC and JEDEC standard.

This section provides the package drawing, thermal specifications, and moisture sensitivity rating for the VSC8530-04 device.

7.1 Package Drawing

The following illustration shows the package drawing for the VSC8530-04 device. The drawing contains the top view, bottom view, side view, dimensions, tolerances, and notes.

Figure 28 • Package Drawing

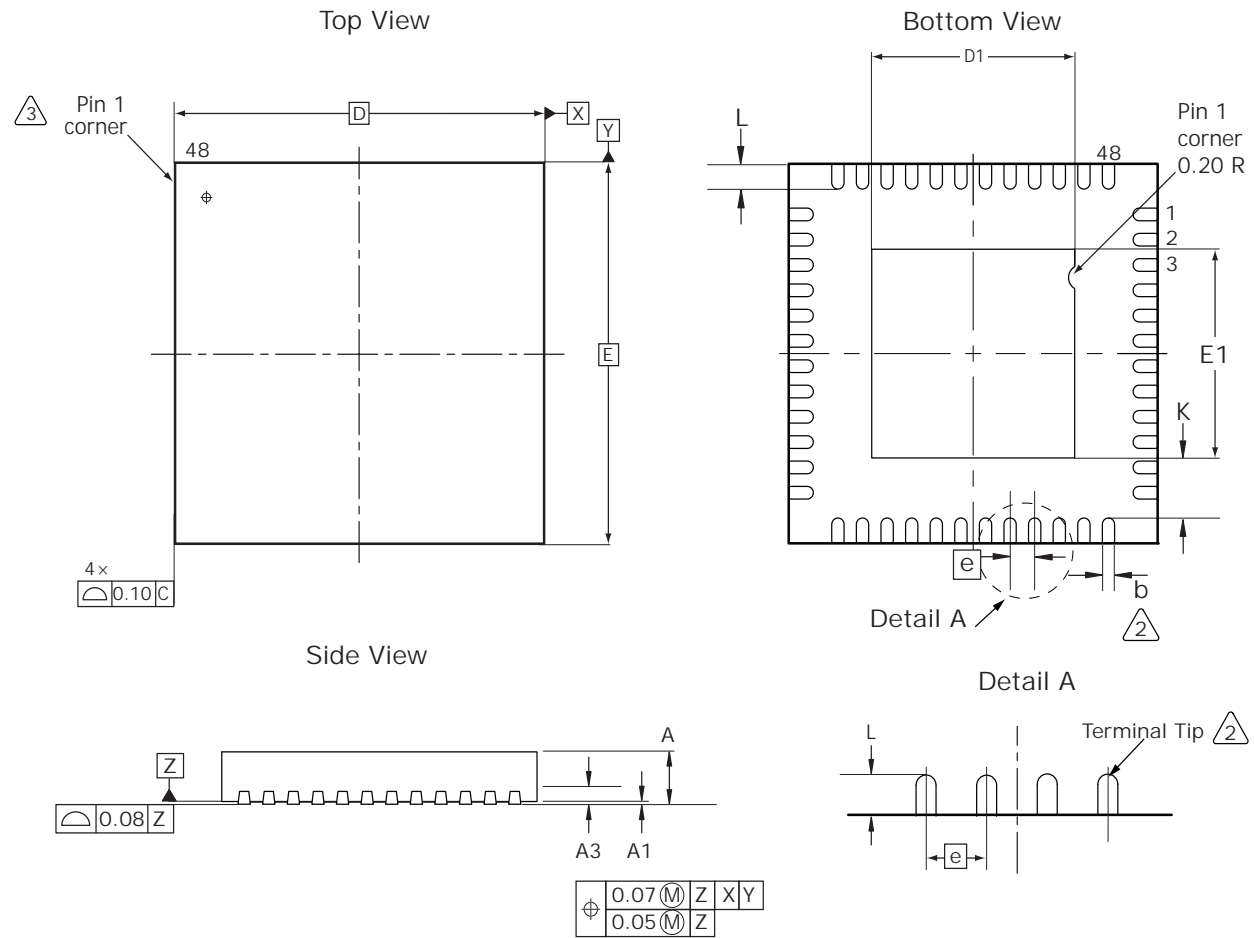

Notes

1. All dimensions and tolerances are in millimeters (mm).
2. Dimension b applies to the metallized terminal and is measured between 0.15 mm and 0.30 mm from the terminal tip.
3. Maximum package warpage is 0.08 mm.

Dimensions and Tolerances

Reference	Minimum	Nominal	Maximum
A	0.80	0.85	0.90
A1	0.00	0.02	0.05
A3		0.203 Ref	
D		6.00 BSC	
D1	3.20	3.30	3.40
E		6.00 BSC	
E1	3.20	3.30	3.40
K		0.95 Ref	
e		0.40 BSC	
L	0.30	0.40	0.50
b	0.15	0.20	0.25

7.2 Thermal Specifications

Thermal specifications for this device are based on the JEDEC JESD51 family of documents. These documents are available on the JEDEC website at www.jedec.org. The thermal specifications are modeled using a four-layer test board with two signal layers, a power plane, and a ground plane (2s2p

PCB). For more information about the thermal measurement method used for this device, see the JESD51-1 standard.

Table 107 • Thermal Resistances

Symbol	°C/W	Parameter
$\theta_{J\text{Ctop}}$	31.62	Die junction to package case top
θ_{JB}	9.34	Die junction to printed circuit board
θ_{JA}	31.73	Die junction to ambient
θ_{JMA} at 1 m/s	25.0	Die junction to moving air measured at an air speed of 1 m/s
θ_{JMA} at 2 m/s	23.75	Die junction to moving air measured at an air speed of 2 m/s

To achieve results similar to the modeled thermal measurements, the guidelines for board design described in the JESD51 family of publications must be applied. For information about applications using QFN packages, see the following:

- JESD51-2A, *Integrated Circuits Thermal Test Method Environmental Conditions, Natural Convection (Still Air)*
- JESD51-6, *Integrated Circuit Thermal Test Method Environmental Conditions, Forced Convection (Moving Air)*
- JESD51-8, *Integrated Circuit Thermal Test Method Environmental Conditions, Junction-to-Board*
- JESD51-7, *High Effective Thermal Conductivity Test Board for Leaded Surface Mount Packages*
- JESD51-5, *Extension of Thermal Test Board Standards for Packages with Direct Thermal Attachment Mechanisms*

7.3 Moisture Sensitivity

This device is rated moisture sensitivity level 3 or better as specified in the joint IPC and JEDEC standard IPC/JEDEC J-STD-020. For more information, see the IPC and JEDEC standard.

8 Design Considerations

This section provides information about design considerations for the VSC8530-04 device.

8.1 10BASE-T signal amplitude

10BASE-T signal amplitude can be lower than the minimum specified in IEEE 802.3 paragraph 14.3.1.2.1 (2.2 V) at low supply voltages. Additionally, associated templates may be marginal or have failures.

This issue is not estimated to present any system-level impact. Performance is not impaired with cables up to 130 m with various link partners.

8.2 Receive error counter only clears when NRESET applied in RMII mode

When operating in RMII MAC interface mode, the receive error counter of register 19 ([Table 32](#), page 31) does not clear upon read-back or software reset of the device. The only way to clear this register while in RMII mode is to assert the NRESET pin of the device.

The receive error counter at register address 19 operates normally in MAC interface modes other than RMII.

8.3 Anomalous PCS error indications in Energy Efficient Ethernet mode

When a port is processing traffic with EEE enabled on the link, certain PCS errors (such as false carriers, spurious start-of-stream detection, and idle errors) and EEE wake errors may occur. There is no effect on traffic bit error rate for cable lengths up to 75 meters, and minor packet loss may occur on links longer than 75 meters.

Regardless of cable length, some error indications should not be used while EEE is enabled. These error indications include false carrier interrupts ([Interrupt Status](#), page 35, bit 3), receive error interrupts ([Interrupt Status](#), page 35, bit 0), and EEE wake error interrupts.

Contact Microsemi for a script that needs to be applied during system initialization if EEE will be enabled.

8.4 10BASE-T half-duplex linkup after initial reset from power up

After initial power up, register 0 (Mode Control) may contain all zeros and thus operate in forced 10BASE-T half-duplex mode.

For applications with register access to the device, the workaround is to perform a software reset using register 0, bit 15 to restore the power-on default values. For more information, see [Mode Control](#), page 26.

For unmanaged applications without register access to the device, see the reset step in [Configuration](#), page 23.

8.5 RGMII interface may not generate even count of preamble nibbles at 10 Mbps

When operating in 10 Mbps mode, the PHY may generate either an even or an odd number of preamble nibbles. Certain third-party RGMII MAC hosts cannot process odd numbers of preamble nibbles, and will drop those odd-count frames. The nibble count output from the PHY is random, depending on input copper signal characteristics.

There is no workaround for those MAC hosts that lack odd-or-even alignment capability for RGMII data streams received at their input pins.

8.6 Default LED0 mode is a non-applicable Gigabit value

The default power-on reset value of register 29 bits 3:0 is 0x1, which is a Link1000/Activity value not applicable to Fast Ethernet devices.

In order to use LED0 on these devices, register 29 must be reprogrammed to applicable Link100/Link10 values.

One such workaround for this issue is to program register 29 bits 3:0 to value 0x2 (LED0 Link 100/Activity), and program bits 7:4 to value 0x3 (LED1 Link 10/Activity).

8.7 Long link up times while in forced 100BASE-TX mode

While in forced 100BASE-TX operation mode and attempting to link up, the device may experience abnormally long link-up times.

The workaround for this issue is to clear all speed advertisements in the autonegotiation advertisement registers (register 4, bits 9:5 and register 9, bits 9:8), then toggle the auto-negotiation enable bit of the mode control register (register 0, bit 12) for a port upon detecting repeated 100BASE-TX link-up attempts. Any advertisements temporarily cleared can then be restored once register 0, bit 12 is cleared.

Please contact Microsemi for the latest software to address this issue.

8.8 Long link up times for 100BASE-TX parallel detection

While parallel-detecting 100BASE-TX link partners and attempting to link up, the device may experience abnormally long link-up times.

The workaround for this issue is to restart media interface auto-negotiation using register 0, bit 9 for a port upon detecting repeated 100BASE-TX link-up attempts.

Please contact Microsemi for the latest software to address this issue.

9 Ordering Information

The VSC8530XMW-04 package is a lead-free (Pb-free), 48-pin, plastic quad flat no-lead (QFN) package with an exposed pad, 6 mm × 6 mm body size, 0.4 mm pin pitch, and 0.9 mm maximum height.

Lead-free products from Microsemi comply with the temperatures and profiles defined in the joint IPC and JEDEC standard IPC/JEDEC J-STD-020. For more information, see the IPC and JEDEC standard.

The following table lists the ordering information for the VSC8530-04 device.

Table 108 • Ordering Information

Part Order Number	Description
VSC8530XMW-04	Lead-free, 48-pin, plastic QFN package with an exposed pad, 6 mm × 6 mm body size, 0.4 mm pin pitch, and 0.9 mm maximum height.