

### **Multilayer Surface Mount Automotive Transient Surge Suppressors**

The AUML Series of Multilayer Transient Surge Suppressors was specifically designed to suppress the destructive transient voltages found in an automobile. The most common transient condition results from large inductive energy discharges. The electronic systems in the automobile, e.g. antilock brake systems, direct ignition systems, engine control, airbag control systems, wiper motor controls, etc., are susceptible to damage from these voltage transients and thus require protection. The AUML transient suppressors have temperature independent suppression characteristics affording protection from -55°C to 125°C.

The AUML suppressor is manufactured from semiconducting ceramics which offer rugged protection and excellent transient energy absorption in a small package. The devices are in ceramic leadless chip form, eliminating lead inductance and assuring fast speed of response to transient surges. These Suppressors require significantly smaller space and land pads than silicon TVS diodes, offering greater circuit board layout flexibility for the designer.

Also see the Harris ML, MLN and MLE Series of Multilayer Suppressors.

### **Features**

- Load Dump Energy Rated per SAE Specification J1113
- Leadless, Surface Mount Chip Form
- "Zero" Lead Inductance
- Variety of Energy Ratings Available
- No Temperature Derating up to 125°C Ambient
- High Peak Surge Current Capability
- Low Profile, Compact Industry Standard Chip Size; (1206, 1210, 1812 and 2220 Sizes)
- Inherent Bidirectional Clamping
- No Plastic or Epoxy Packaging Assures Better than 94V-0 Flammability Rating

### **Packaging**

**AUML SERIES**

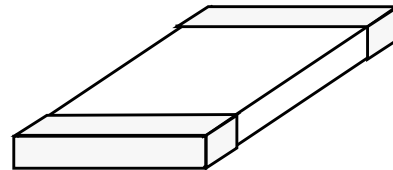

# AUML Series

**Absolute Maximum Ratings** For ratings of individual members of a series, see Device Ratings and Specifications chart

	AUML SERIES	UNITS
Continuous:		
Steady State Applied Voltage:		
DC Voltage Range ( $V_{M(DC)}$ ) .....	18	V
Transient:		
Load Dump Energy, ( $W_{LD}$ ) .....	1.5 to 25	J
Jump Start Capability (5 minutes), ( $V_{JUMP}$ ) .....	24.5	V
Operating Ambient Temperature Range ( $T_A$ ) .....	-55 to 125	$^{\circ}C$
Storage Temperature Range ( $T_{STG}$ ) .....	-55 to 150	$^{\circ}C$
Temperature Coefficient ( $\alpha_V$ ) of Clamping Voltage ( $V_C$ ) at Specified Test Current. ....	<0.01	$\%/^{\circ}C$

*CAUTION: Stresses above those listed in "Absolute Maximum Ratings" may cause permanent damage to the device. This is a stress only rating and operation of the device at these or any other conditions above those indicated in the operational sections of this specification is not implied.*

## Device Ratings and Specifications

PART NUMBER	MAXIMUM RATINGS (125 $^{\circ}C$ )			SPECIFICATIONS (25 $^{\circ}C$ )				
	MAXIMUM CONTINUOUS DC VOLTAGE	JUMP START VOLTAGE (5 MIN)	LOAD DUMP ENERGY (10 PULSES)	NOMINAL VARISTOR VOLTAGE AT 10mA DC TEST CURRENT		MAXIMUM STANDBY LEAKAGE (AT 13VDC)	MAXIMUM CLAMPING VOLTAGE ( $V_C$ ) AT TEST CURRENT (8/20 $\mu$ s)	
	$V_{M(DC)}$	$V_{JUMP}$	$W_{LD}$	$V_{N(DC)}$ MIN	$V_{N(DC)}$ MAX	$I_L$	$V_C$	$I_P$
	(V)	(V)	(J)	(V)	(V)	( $\mu$ A)	(V)	(A)
V18AUMLA1206	18	24.5	1.5	23	32	50	40	1.5
V18AUMLA1210	18	24.5	3	23	32	50	40	1.5
V18AUMLA1812	18	24.5	6	23	32	100	40	5
V18AUMLA2220	18	24.5	25	23	32	200	40	10

**NOTES:**

1. Average power dissipation of transients not to exceed 0.1W, 0.15W, 0.3W and 1W for model sizes 1206, 1210, 1812 and 2220 respectively.
2. Load dump energy rating (into the suppressor) of a voltage transient with a resultant time constant of 115ms to 230ms.
3. Thermal shock capability per Mil-Std-750, Method 1051: -55 $^{\circ}C$  to 125 $^{\circ}C$ , 5 minutes at 25 $^{\circ}C$ , 25 Cycles: 15 minutes at each extreme.
4. For application specific requirements, please contact Harris sales office.

## Power Dissipation Ratings

When transients occur in rapid succession, the average power dissipation is the energy (watt-seconds) per pulse times the number of pulses per second. The power so developed must be within the specifications shown on the Device Ratings and Characteristics table for the specific device. Certain parameter ratings must be derated at high temperatures as shown in Figure 1.

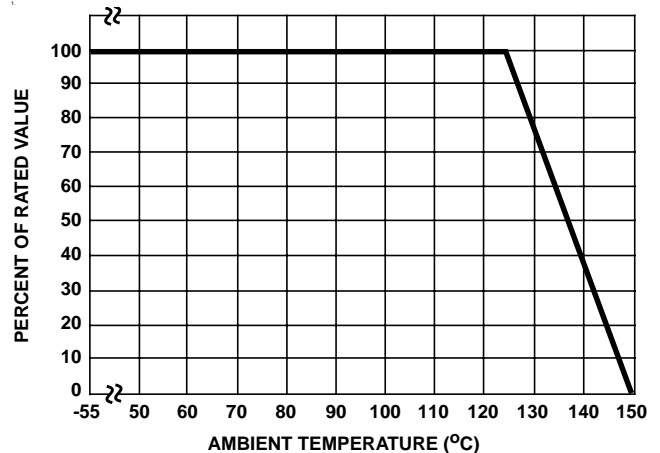

**FIGURE 1. CURRENT, ENERGY AND POWER DERATING CURVE**

V-I Characteristics Curves

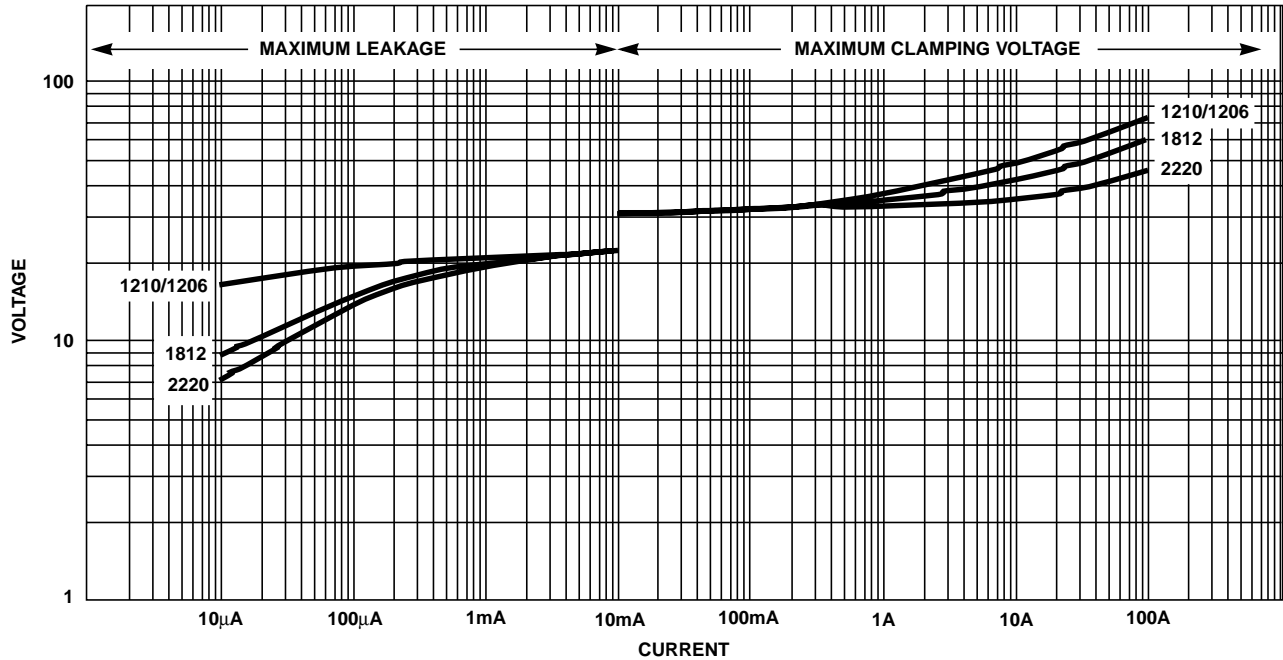

FIGURE 2. MAXIMUM LEAKAGE CURRENT/CLAMPING VOLTAGE CURVE FOR AUML SERIES AT 25°C

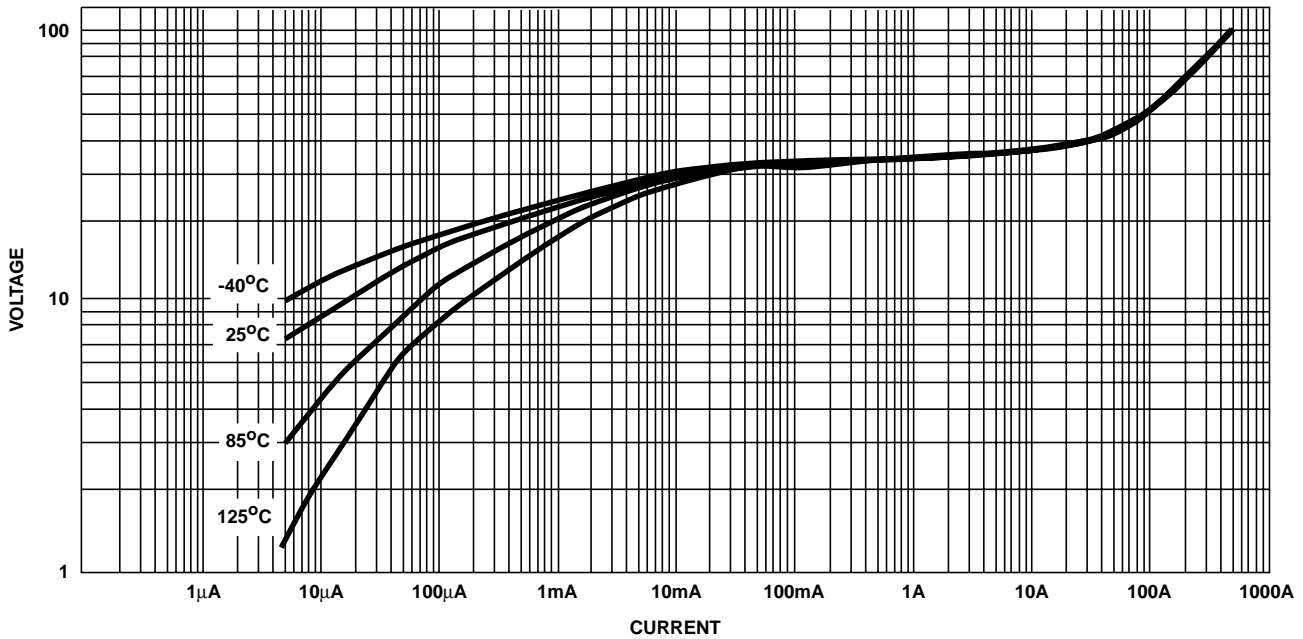

FIGURE 3. TYPICAL V-I CHARACTERISTICS OF THE V18AUMLA2220 at -40°C, 25°C, 85°C AND 125°C

Temperature Effects

In the leakage region of the AUML suppressor, the device characteristics approaches a linear (ohmic) relationship and shows a temperature dependent affect. In this region the suppressor is in a high resistance mode (approaching  $10^6\Omega$ ) and appears as a near open-circuit. Leakage currents at maximum rated voltage are in the microamp range. When

clamping transients at higher currents (at and above the ten milliamp range), the AUML suppressor approaches a 1-10 $\Omega$  characteristic. In this region the characteristics of the AUML are virtually temperature independent. Figure 3 shows the typical effect of temperature on the V-I characteristics of the AUML suppressor.

## Load Dump Energy Capability

A Load dump transient occurs when the alternator load in the automobile is abruptly reduced. The worst case scenario of this transient occurs when the battery is disconnected while operating at full rated load. There are a number of different load dump specifications in existence in the automotive industry, with the most common one being that recommended by the Society of Automotive Engineers, specification #SAE J1113. Because of the diversity of these load dump specifications Harris defines the load dump energy capability of the AUML suppressor range as that energy dissipated by the device itself, independent of the test circuit setup. The resultant load dump energy handling capability serves as an excellent figure of merit for the AUML suppressor.

Standard load dump specifications require a device capability of 10 pulses at rated energy, across a temperature range of -40°C to 125°C. This capability requirement is well within the ratings of all of the AUML series (Figure 5).

Further testing on the AUML series has concentrated on extending the number of load dump pulses, at rated energy, which are applied to the devices. The reliability information thus generated gives an indication of the inherent capability of these devices. As an example of device durability the 1210 size has been subjected to over 2000 pulses at its rated energy of 3 joules; the 1812 size have been pulsed over 1000 times at 6 joules and 2220 size has been pulsed at its rated energy of 25 joules over 300 times. In all cases there has been little or no change in the device characteristics (Figure 6).

The very high energy absorption capability of the AUML suppressor is achieved by means of a highly controlled manufacturing process. This technology ensures that a large volume of suppressor material, with an interdigitated layer construction, is available for energy absorption in an extremely small package. Unlike equivalent rated silicon TVS diodes, the entire AUML device volume is available to

dissipate the load dump energy. Hence, the peak temperatures generated by the load dump transient are significantly lower and evenly dissipated throughout the complete device (Figure 4). This even energy dissipation ensures that there are lower peak temperatures generated at the P-N grain boundaries of the AUML suppressor.

There are a number of different size devices available in the AUML series, each one with a load dump energy rating, which is size dependent.

Experience has shown that while the effects of a load dump transient is of real concern, its frequency of occurrence is much less than those of low energy inductive spikes. Such low energy inductive spikes may be generated as a result of motors switching on and off, from ESD occurrences, fuse blowing, etc. It is essential that the suppression technology selected also has the capability to suppress such transients. Testing on the V18AUMLA2220 has shown that after being subjected to a repetitive energy pulse of 2 joules, over 6000 times, no characteristic changes have occurred (Figure 7.)

## Speed of Response

The clamping action of the AUML suppressor depends on a conduction mechanism similar to that of other semiconductor devices (i.e. P-N Junctions). The apparent slow response time often associated with transient voltage suppressors (Zeners, MOVs) is often due to parasitic inductance in the package and leads of the device and less dependent of the basic material (silicon, zinc oxide). Thus, the single most critical element affecting the response time of any suppressor is its lead inductance. The AUML suppressor is a surface mount device, with no leads or external packaging, and thus, it has virtually zero inductance. The actual response time of a AUML surge suppressor is in the 1 to 5 nanosecond range, more than sufficient for the transients which are likely to be encountered in an automotive environment.

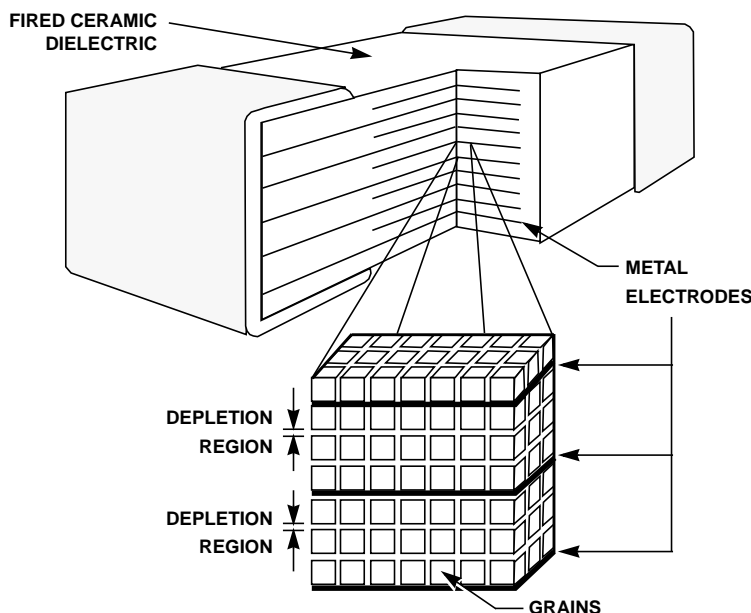

FIGURE 4. INTERDIGITATED CONSTRUCTION OF AUML SUPPRESSOR

# AUML Series

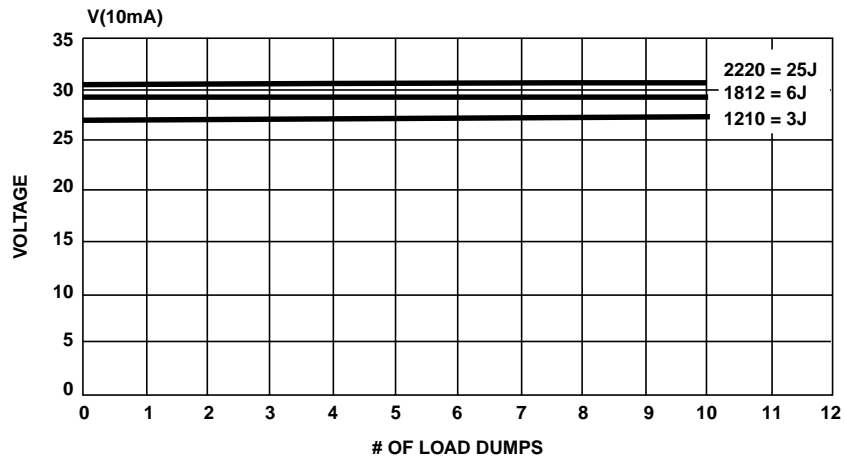

FIGURE 5. AUML LOAD DUMP PULSING OVER A TEMPERATURE RANGE OF -55°C TO 125°C

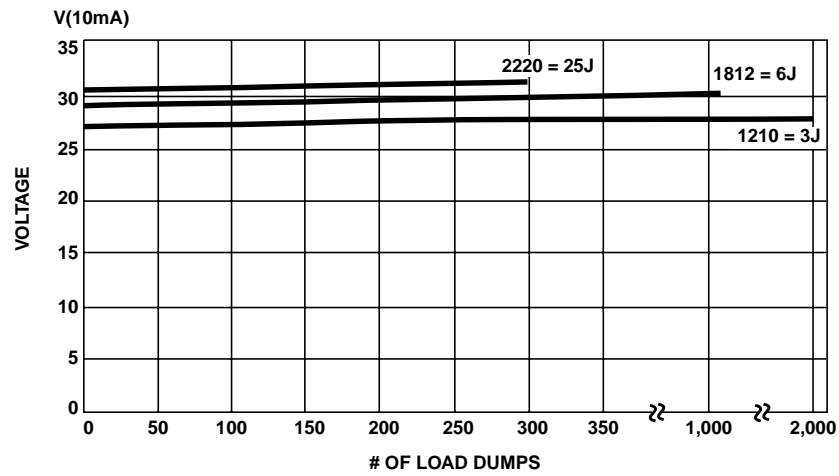

FIGURE 6. REPETITIVE LOAD DUMP PULSING AT RATED ENERGY

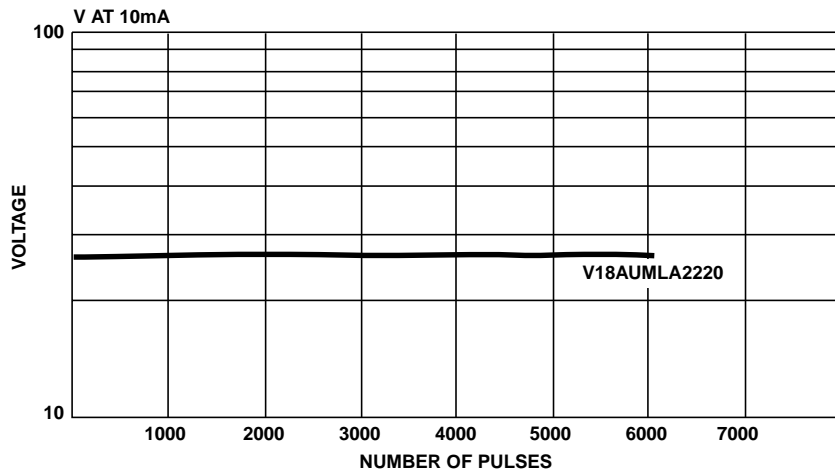

FIGURE 7. REPETITIVE ENERGY TESTING OF THE V18AUMLA2220 AT AN ENERGY LEVEL OF 2 JOULES

### Soldering Recommendations

The principal techniques used for the soldering of components in surface mount technology are Infra Red (IR) Reflow, Vapour Phase Reflow, and Wave Soldering. When wave soldering, the suppressor is attached to the circuit board by means of an adhesive. The assembly is then placed on a conveyor and run through the soldering process to contact the wave. With IR and Vapour Phase Reflow, the device is placed in a solder paste on the substrate. As the solder paste is heated, it reflows and solders the unit to the board.

The recommended solder is a 62/36/2 (Sn/Pb/Ag), 60/40 (Sn/Pb), or 63/37 (Sn/Pb). Harris also recommends an RMA solder flux.

Wave soldering is the most strenuous of the processes. To avoid the possibility of generating stresses due to thermal shock, a preheat stage in the soldering process is recommended, and the peak temperature of the solder process should be rigidly controlled.

When using a reflow process, care should be taken to ensure that the chip is not subjected to a thermal gradient steeper than 4 degrees per second; the ideal gradient being 2 degrees per second. During the soldering process, preheating to within 100 degrees of the solders peak temperature is essential to minimize thermal shock. Examples of the soldering conditions for the AUML Series of suppressors are given in the tables below.

Once the soldering process has been completed, it is still necessary to ensure that any further thermal shocks are avoided. One possible cause of thermal shock is hot printed circuit boards being removed from the solder process and subjected to cleaning solvents at room temperature. The boards must be allowed to gradually cool to less than 50°C before cleaning.

### Termination Options

Harris offers two types of electrode termination finish for the Multilayer product series:

1. Silver/Platinum (standard)
2. Silver/Palladium (optional)

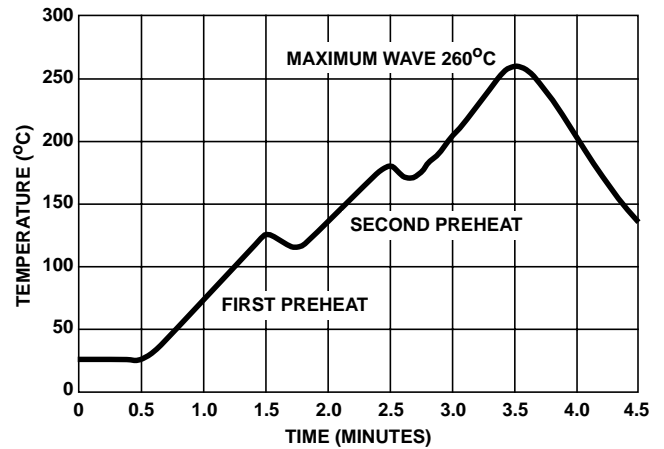

FIGURE 8. WAVE SOLDER PROFILE

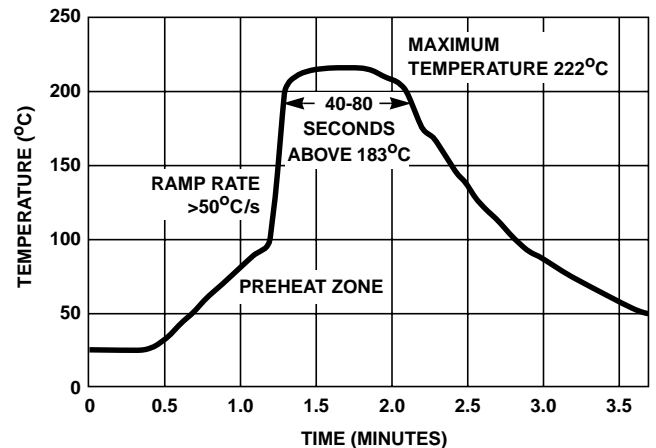

FIGURE 9. VAPOR PHASE SOLDER PROFILE

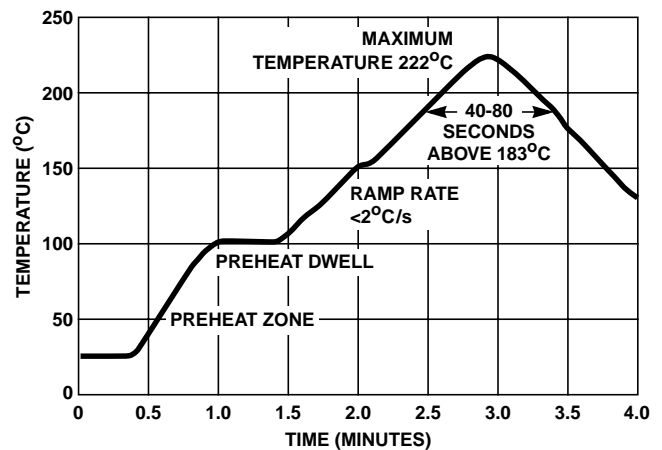
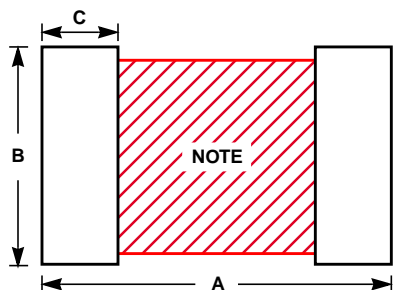

FIGURE 10. REFLOW SOLDER PROFILE

**Recommended Pad Outline**



NOTE: Avoid metal runs in this area.

**Leakage Current ( $I_L$ )**

In the nonconducting mode, the device is at a very high impedance (approaching  $10^6\Omega$  at its rated working voltage) and appears as an almost open circuit in the system. The leakage current drawn at this level is very low ( $<25\mu A$  at ambient temperature) and, unlike the zener diode, the multilayer TVS has the added advantage that, when operated up to its maximum temperature, its leakage current will not increase above  $500\mu A$ .

**Nominal Voltage ( $V_{N(DC)}$ )**

This is the voltage at which the AUML enters its conduction state and begins to suppress transients. In the automotive environment this voltage is defined at the 10mA point and has a minimum ( $V_{N(DC) MIN}$ ) and maximum ( $V_{N(DC) MAX}$ ) voltage specified.

SYMBOL	CHIP SIZE							
	1206		1210		1812		2220	
	IN	MM	IN	MM	IN	MM	IN	MM
A	0.203	5.15	0.219	5.51	0.272	6.91	0.315	8.00
B	0.103	2.62	0.147	3.73	0.172	4.36	0.240	6.19
C	0.065	1.65	0.073	1.85	0.073	1.85	0.073	1.85

**Explanation of Terms**

**Maximum Continuous DC Working Voltage ( $V_{M(DC)}$ )**

This is the maximum continuous DC voltage which may be applied, up to the maximum operating temperature ( $125^\circ C$ ), to the ML suppressor. This voltage is used as the reference test point for leakage current and is always less than the breakdown voltage of the device.

**Load Dump Energy Rating ( $W_{LD}$ )**

This is the actual energy the part is rated to dissipate under load dump conditions (not to be confused with the “source energy” of a load dump test specification).

**Maximum Clamping Voltage ( $V_C$ )**

This is the peak voltage appearing across the suppressor when measured at conditions of specified pulse current and specified waveform ( $8/20\mu s$ ). It is important to note that the peak current and peak voltage may not necessarily be coincidental in time.

**Mechanical Dimensions**

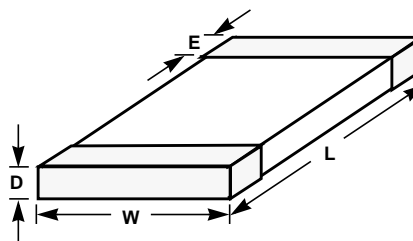

SYMBOL	CHIP SIZE							
	1206		1210		1812		2220	
	IN	MM	IN	MM	IN	MM	IN	MM
D MAX	0.071	1.80	0.070	1.80	0.07	1.8	0.118	3.00
E	0.02 $\pm 0.01$	0.50 $\pm 0.25$	0.02 $\pm 0.01$	0.50 $\pm 0.25$	0.02 $\pm 0.01$	0.5 $\pm 0.25$	0.03 $\pm 0.01$	0.75 $\pm 0.25$
L	0.125 $\pm 0.012$	3.20 $\pm 0.03$	0.125 $\pm 0.012$	3.20 $\pm 0.30$	0.18 $\pm 0.014$	4.5 $\pm 0.35$	0.225 $\pm 0.016$	5.7 $\pm 0.4$
W	0.06 $\pm 0.011$	1.60 $\pm 0.28$	0.10 $\pm 0.012$	2.54 $\pm 0.30$	0.125 $\pm 0.012$	3.2 $\pm 0.30$	0.197 $\pm 0.016$	5 $\pm 0.4$

Ordering Information

V18AUMLAXXX TYPES

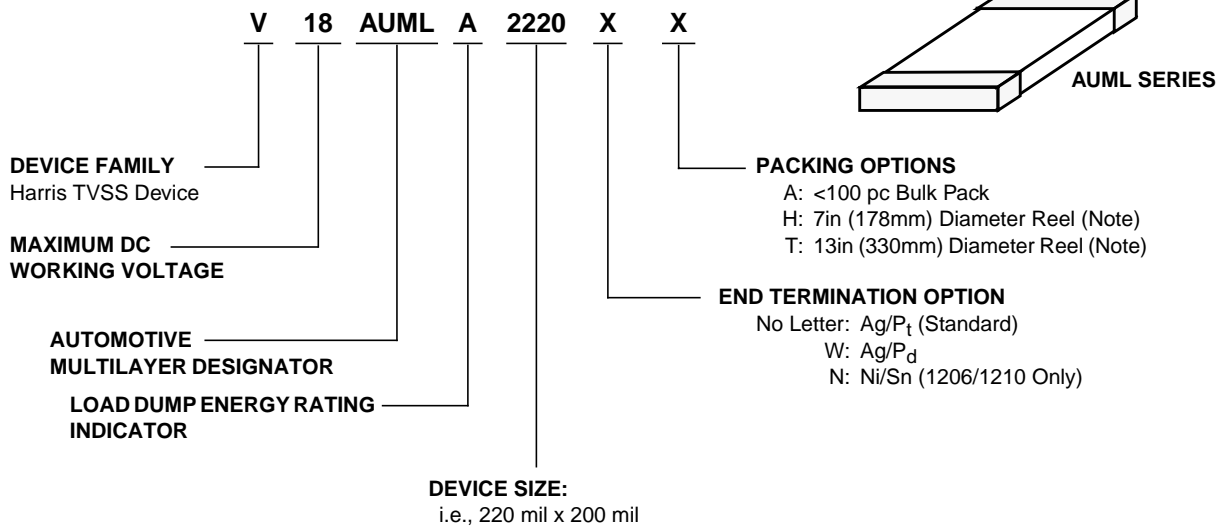

NOTE: See quantity table.

Standard Shipping Quantities

DEVICE SIZE	"13" INCH REEL ("T" OPTION)	"7" INCH REEL ("H" OPTION)	BULK PACK ("A" OPTION)
1206	10,000	2,500	100
1210	8,000	2,000	100
1812	4,000	1,000	100
2220	4,000	1,000	100

Tape and Reel Specifications

- Conforms to EIA - 481, Revision A
- Can be Supplied to IEC Publication 286 - 3

TAPE	8mm WIDE TAPE		12mm WIDE TAPE	
Chip Size	1206	1210	1812	2220

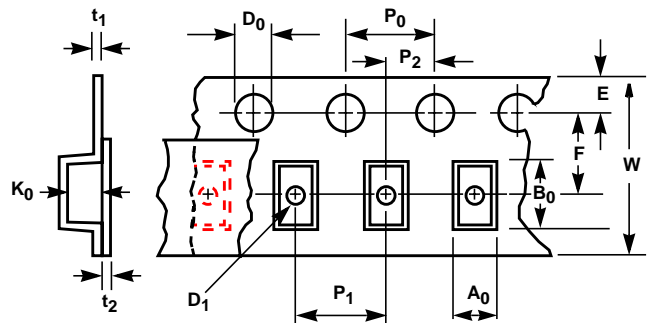

## AUML Series

SYMBOL	DESCRIPTION	TAPE WIDTH	
		8mm	12mm
A <sub>0</sub>	Width of Cavity	Dependent on Chip Size to Minimize Rotation.	
B <sub>0</sub>	Length of Cavity	Dependent on Chip Size to Minimize Rotation.	
K <sub>0</sub>	Depth of Cavity	Dependent on Chip Size to Minimize Rotation.	
W	Width of Tape	8 ± 0.2	12 ± 0.2
F	Distance Between Drive Hole Centers and Cavity Centers	3.5 ± 0.5	5.4 ± 0.5
E	Distance Between Drive Hole Centers and Tape Edge	1.75 ± 0.1	
P <sub>1</sub>	Distance Between Cavity Center	4 ± 0.1	8 ± 0.1
P <sub>2</sub>	Axial Distance Between Drive Hole Centers and Cavity Centers	2 ± 0.1	
P <sub>0</sub>	Axial Distance Between Drive Hole Centers	8 ± 0.1	
D <sub>0</sub>	Drive Hole Diameter	1.55 ± 0.05	
D <sub>1</sub>	Diameter of Cavity Piercing	1.05 ± 0.05	1.55 ± 0.05
t <sub>1</sub>	Embossed Tape Thickness	0.3 Max	0.4 Max
t <sub>2</sub>	Top Tape Thickness	0.1 Max	

NOTE: Dimensions in millimeters.

### Standard Packaging

Tape and reel is the standard packaging method of the AUML series. The standard 330 millimeter (13 inch) reel utilized contains 4000 pieces for the 2220 and 1812 chips, 8000 pieces for the 1210 chip and 10,000 pieces for the 1206 size. To order add "T" to the standard part number, e.g. V18AUMLA2220T.

### Special Packaging

Option 1: 178 millimeter (7 inch) reels containing 1000 (2220, 1812), 2000 (1210), 2500 (1206), pieces are available. To order add "H" to the standard part number, e.g. V18AUMLA2220H.

Option 2: For small sample quantities (less than 100 pieces) the units are shipped bulk pack. To order add "A" to the standard part number, e.g. V18AUMLA2220A.

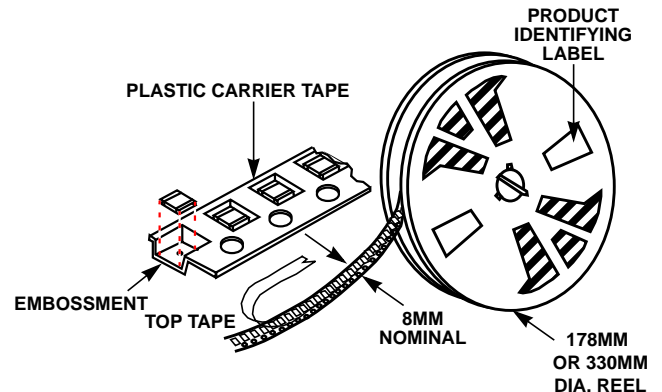

All Harris semiconductor products are manufactured, assembled and tested under **ISO9000** quality systems certification.

*Harris semiconductor products are sold by description only. Harris Semiconductor Communications Division reserves the right to make changes in circuit design and/or specifications at any time without notice. Accordingly, the reader is cautioned to verify that data sheets are current before placing orders. Information furnished by Harris is believed to be accurate and reliable. However, no responsibility is assumed by Harris or its subsidiaries for its use; nor for any infringements of patents or other rights of third parties which may result from its use. No license is granted by implication or otherwise under any patent or patent rights of Harris or its subsidiaries.*

For information regarding Harris' Semiconductor Communications Division and its products, call **1-800-4-HARRIS** or see web site <http://www.semi.harris.com>