

## Advance Information

This document contains information on a product under development. The parametric information contains target parameters that are subject to change.



# Bt8970

## Single-Chip HDSL Transceiver

### Functional Block Diagram

The Bt8970 is a full-duplex 2B1Q transceiver based on Rockwell's High-Bit-Rate Digital Subscriber Line (HDSL) technology. It supports transmission of more than 18,000 feet over 26 AWG copper telephone wire without repeaters. Small size and low power dissipation makes the Bt8970 ideal for line-powered digital access, voice pairgain, and HDSL systems.

The Bt8970 is a highly integrated device that includes all of the active circuitry needed for a complete 2B1Q transceiver. In the receive portion of the Bt8970, a variable gain amplifier optimizes the signal level according to the dynamic range of the analog-to-digital converter. Once the signal is digitized, sophisticated adaptive echo cancellation, equalization, and detection DSP algorithms reproduce the originally transmitted far-end signal.

In the transmitter, the transmit source and scrambler operation is programmable via the microcomputer interface. A highly linear digital-to-analog converter with programmable gain sets the transmission power for optimal performance. A pulse-shaping filter and a low-distortion line driver generate the signal characteristics needed to drive a large range of subscriber lines at low-bit error rates.

Startup and performance monitoring operations are controlled via the microprocessor interface. C-language source code supporting these operations is supplied under a no-fee license agreement from Rockwell. The Bt8970 includes a glueless interface to both Intel and Motorola microprocessors.

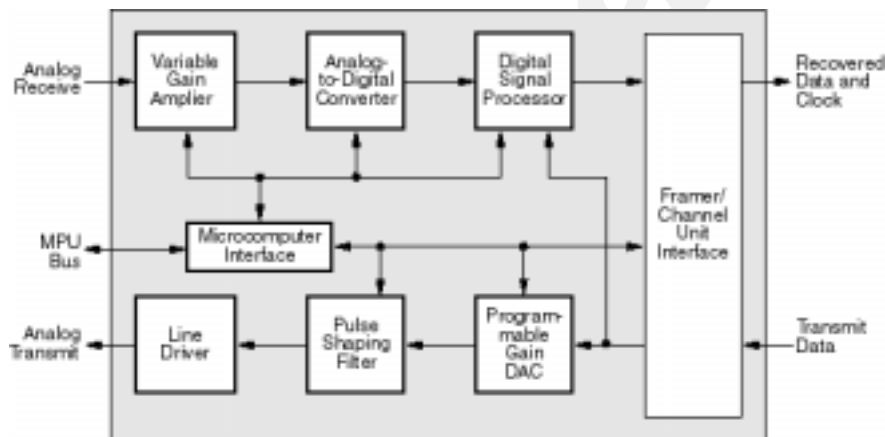

### Distinguishing Features

- Single-chip 2B1Q transceiver solution
- All 2B1Q transceiver functions integrated into a single monolithic device
  - Receiver gain control and A/D converter
  - DSP functions including echo cancellation, equalization, timing recovery, and symbol detection
  - Programmable gain transmit DAC, pulse-shaping filter, and line driver
- Supports operation from 160 to 1552 kbps
- Capable of transceiving over the ANSI T1E1.4/94-006 and ETSI ETR 152 HDSL test loops
- Flexible Monitoring and Control
  - Glueless interface to Intel 8051 and Motorola 68302 processors
  - Access to embedded filters, performance meters and timers
- Backwards compatible with Bt8952 and Bt8960 software API commands
- Pin compatible with Bt8960
- JTAG/IEEE Std 1149.1-1990 compliant
- Single +5 V power supply operation with option for 3.3 V to reduce power consumption
- 100-pin PQFP package
- -40°C to +85°C operation
- 700 mW power consumption at 784 kbps (max using 3.3 V option)

### Applications

- E1 and T1 HDSL transport
- Voice/data pairgain systems
- Internet connectivity
- ISDN basic-rate interface concentrators
- Extended range fractional T1/E1
- Cellular/microcellular base stations
- Personal Communications Systems (PCS) radio ports and cell switches

## Ordering Information

Model Number	Package	Ambient Temperature Range
Bt8970EHF	100-Pin Plastic Quad Flat Pack (PQFP)	-40°C to +85°C

## Revision History

Revision	Level	Date	Description
A	Advance	July 1998	Created
B	—	November 2000	Conexant template

© 1997, 2000, Conexant Systems, Inc.  
All Rights Reserved.

Information in this document is provided in connection with Conexant Systems, Inc. ("Conexant") products. These materials are provided by Conexant as a service to its customers and may be used for informational purposes only. Conexant assumes no responsibility for errors or omissions in these materials. Conexant may make changes to specifications and product descriptions at any time, without notice. Conexant makes no commitment to update the information and shall have no responsibility whatsoever for conflicts or incompatibilities arising from future changes to its specifications and product descriptions.

No license, express or implied, by estoppel or otherwise, to any intellectual property rights is granted by this document. Except as provided in Conexant's Terms and Conditions of Sale for such products, Conexant assumes no liability whatsoever.

THESE MATERIALS ARE PROVIDED "AS IS" WITHOUT WARRANTY OF ANY KIND, EITHER EXPRESS OR IMPLIED, RELATING TO SALE AND/OR USE OF CONEXANT PRODUCTS INCLUDING LIABILITY OR WARRANTIES RELATING TO FITNESS FOR A PARTICULAR PURPOSE, CONSEQUENTIAL OR INCIDENTAL DAMAGES, MERCHANTABILITY, OR INFRINGEMENT OF ANY PATENT, COPYRIGHT OR OTHER INTELLECTUAL PROPERTY RIGHT. CONEXANT FURTHER DOES NOT WARRANT THE ACCURACY OR COMPLETENESS OF THE INFORMATION, TEXT, GRAPHICS OR OTHER ITEMS CONTAINED WITHIN THESE MATERIALS. CONEXANT SHALL NOT BE LIABLE FOR ANY SPECIAL, INDIRECT, INCIDENTAL, OR CONSEQUENTIAL DAMAGES, INCLUDING WITHOUT LIMITATION, LOST REVENUES OR LOST PROFITS, WHICH MAY RESULT FROM THE USE OF THESE MATERIALS.

Conexant products are not intended for use in medical, lifesaving or life sustaining applications. Conexant customers using or selling Conexant products for use in such applications do so at their own risk and agree to fully indemnify Conexant for any damages resulting from such improper use or sale.

The following are trademarks of Conexant Systems, Inc.: Conexant™, the Conexant C symbol, and "What's Next in Communications Technologies"™. Product names or services listed in this publication are for identification purposes only, and may be trademarks of third parties. Third-party brands and names are the property of their respective owners.

For additional disclaimer information, please consult Conexant's Legal Information posted at [www.conexant.com](http://www.conexant.com), which is incorporated by reference.

**Reader Response:** Conexant strives to produce quality documentation and welcomes your feedback. Please send comments and suggestions to [tech.pubs@conexant.com](mailto:tech.pubs@conexant.com). For technical questions, contact your local Conexant [sales office](#) or field applications engineer.

# Table of Contents

---

List of Figures .....	v
List of Tables .....	vii
<b>1.0 System Overview</b> .....	1-1
<b>1.1 Functional Summary</b> .....	1-1
1.1.1 Transmit Section .....	1-3
1.1.2 Receive Section .....	1-3
1.1.3 Timing Recovery and Clock Interface .....	1-3
1.1.4 Microcomputer Interface .....	1-4
1.1.5 Test and Diagnostic Interface (JTAG) .....	1-4
<b>1.2 Pin Descriptions</b> .....	1-5
<b>2.0 Functional Description</b> .....	2-1
<b>2.1 Transmit Section</b> .....	2-1
2.1.1 Symbol Source Selector/Scrambler .....	2-1
2.1.2 Variable Gain Digital-to-Analog Converter .....	2-3
2.1.3 Pulse-Shaping Filter .....	2-3
2.1.4 Line Driver .....	2-3
<b>2.2 Receive Section</b> .....	2-4
2.2.1 Variable Gain Amplifier .....	2-4
2.2.2 Analog-to-Digital Converter .....	2-4
2.2.3 Digital Signal Processor .....	2-5
2.2.4 Echo Cancellor .....	2-7
2.2.5 Equalizer .....	2-8
2.2.6 Detector .....	2-9
<b>2.3 Timing Recovery and Clock Interface</b> .....	2-12
<b>2.4 Channel Unit Interface</b> .....	2-14

2.5	<b>Microcomputer Interface</b> .....	2-16
2.5.1	Source Code .....	2-16
2.5.2	Microcomputer Read/Write .....	2-16
2.5.3	Interrupt Request .....	2-17
2.5.4	Reset .....	2-17
2.5.5	Registers .....	2-17
2.5.6	Timers .....	2-17
2.6	<b>Test and Diagnostic Interface (JTAG)</b> .....	2-19
3.0	<b>Register Summary</b> .....	3-1
4.0	<b>Register</b> .....	4-1
5.0	<b>Electrical &amp; Mechanical Specifications</b> .....	5-1
5.1	Absolute Maximum Ratings .....	5-1
5.2	Recommended Operating Conditions .....	5-2
5.3	Electrical Characteristics .....	5-3
5.4	Clock Timing .....	5-4
5.5	Channel Unit Interface Timing .....	5-6
5.6	<b>Microcomputer Interface Timing</b> .....	5-10
5.6.1	Test and Diagnostic Interface Timing .....	5-15
5.6.2	Analog Specifications .....	5-17
5.6.3	Test Conditions .....	5-19
5.7	Timing Measurements .....	5-21
5.8	Mechanical Specifications .....	5-23

11/29/00 10:00 A.M.

# List of Figures

Figure 1-1.	HDSL T1/E1 Terminal .....	1-1
Figure 1-2.	Bt8970 Detailed Block Diagram .....	1-2
Figure 1-3.	Pin Diagram .....	1-5
Figure 2-1.	Transmit Section Block Diagram .....	2-1
Figure 2-2.	First-Order Echo Cancellation Using the Variable Gain Amplifier .....	2-4
Figure 2-3.	Receiver Digital Signal Processing .....	2-5
Figure 2-4.	Digital Front-End Block Diagram .....	2-6
Figure 2-5.	Timing Recovery and Clock Interface Block Diagram .....	2-12
Figure 2-6.	Serial Sign-Bit First Mode .....	2-14
Figure 2-7.	Parallel Master Mode .....	2-14
Figure 2-8.	Parallel Slave Mode .....	2-15
Figure 5-1.	MCLK Timing Requirements .....	5-4
Figure 5-2.	Clock Control Timing .....	5-5
Figure 5-3.	Channel Unit Interface Timing, Parallel Master Mode .....	5-6
Figure 5-4.	Channel Unit Interface Timing, Parallel Slave Mode .....	5-8
Figure 5-5.	Channel Unit Interface Timing, Serial Mode .....	5-9
Figure 5-6.	MCI Write Timing, Intel Mode (MOTEL = 0) .....	5-12
Figure 5-7.	MCI Write Timing, Motorola Mode (MOTEL = 1) .....	5-12
Figure 5-8.	MCI Read Timing, Intel Mode (MOTEL = 0) .....	5-13
Figure 5-9.	MCI Read Timing, Motorola Mode (MOTEL = 1) .....	5-14
Figure 5-10.	Internal Write Timing .....	5-15
Figure 5-11.	JTAG Interface Timing .....	5-16
Figure 5-12.	SMON Timing .....	5-16
Figure 5-13.	Transmitted Pulse Template .....	5-18
Figure 5-14.	Transmitter Test Circuit .....	5-19
Figure 5-15.	Standard Output Load (Totem Pole and Three-State Outputs) .....	5-20
Figure 5-16.	Open-Drain Output Load (IRQ) .....	5-20
Figure 5-17.	Input Waveforms for Timing Tests .....	5-21
Figure 5-18.	Output Waveforms for Timing Tests .....	5-21
Figure 5-19.	Output Waveforms for Three-state Enable and Disable Tests .....	5-22
Figure 5-20.	100-Pin Plastic Quad Flat Pack (PQFP) .....	5-23

Preliminary Review

11/29/00 10:00 A.M.

# List of Tables

Table 1-1.	Pin Descriptions . . . . .	1-6
Table 1-2.	Hardware Signal Definitions . . . . .	1-7
Table 2-1.	Symbol Source Selector/Scrambler Modes . . . . .	2-2
Table 2-2.	Four-Level Bit-to-Symbol Conversions . . . . .	2-2
Table 2-3.	Two-Level Bit-to-Symbol Conversions . . . . .	2-2
Table 2-4.	Two-Level Symbol-to-Bit Conversion . . . . .	2-9
Table 2-5.	Four-Level Symbol-to-Bit Conversion . . . . .	2-10
Table 2-6.	Crystal Oscillator Circuit Component Values . . . . .	2-13
Table 2-7.	Timers . . . . .	2-18
Table 2-8.	JTAG Device Identification Register . . . . .	2-19
Table 3-1.	Register Table . . . . .	3-1
Table 5-1.	Absolute Maximum Ratings . . . . .	5-1
Table 5-2.	Recommended Operating Conditions . . . . .	5-2
Table 5-3.	Electrical Characteristics . . . . .	5-3
Table 5-4.	External Clock Timing Requirements (MCLK) . . . . .	5-4
Table 5-5.	HCLK Switching Characteristics . . . . .	5-4
Table 5-6.	Symbol Clock (QCLK) Switching Characteristics . . . . .	5-5
Table 5-7.	Channel Unit Interface Timing Requirements, Parallel Master Mode . . . . .	5-6
Table 5-8.	Channel Unit Interface Switching Characteristics, Parallel Master Mode . . . . .	5-6
Table 5-9.	Channel-Unit Interface Timing Requirements, Parallel Slave Mode . . . . .	5-7
Table 5-10.	Channel Unit Interface Switching Characteristics, Parallel Slave Mode . . . . .	5-7
Table 5-11.	Channel Unit Interface Timing Requirements, Serial Mode . . . . .	5-8
Table 5-12.	Channel Unit Interface Switching Characteristics, Serial Mode . . . . .	5-8
Table 5-13.	Microcomputer Interface Timing Requirements . . . . .	5-10
Table 5-14.	Microcomputer Interface Switching Characteristics . . . . .	5-11
Table 5-15.	Test and Diagnostic Interface Timing Requirements . . . . .	5-15
Table 5-16.	Test and Diagnostic Interface Switching Characteristics . . . . .	5-16
Table 5-17.	Receiver Analog Requirements and Specifications . . . . .	5-17
Table 5-18.	Transmitter Analog Requirements and Specifications . . . . .	5-18
Table 5-19.	Transmitted Pulse Template . . . . .	5-19
Table 5-20.	Transmitter Test Circuit Component Values . . . . .	5-20

Preliminary Review

11/29/00 10:00 A.M.

# 1.0 System Overview

## 1.1 Functional Summary

The Bt8970 HDSL transceiver is an integral component of Rockwell's HDSL chipset. System performance of the chipset allows 2-pair T1, 2-pair E1, and 3-pair E1 transmission. The major building blocks of a typical HDSL T1/E1 terminal are shown in Figure 1-1.

Figure 1-1. HDSL T1/E1 Terminal

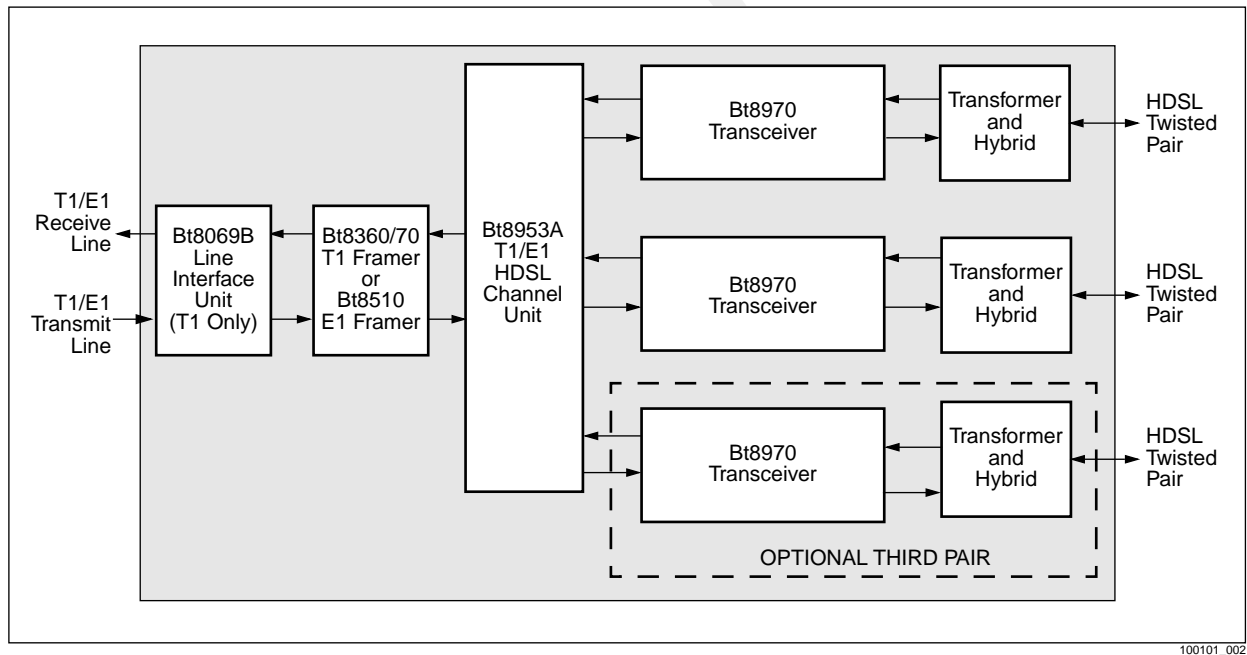

The Bt8970 comprises five major functions: a transmit section, a receive section, a timing recovery and clock interface, a microcomputer interface, and a test and diagnostic interface. Figure 1-2 details the connections within and between each of these functional blocks.

Figure 1-2. Bt8970 Detailed Block Diagram

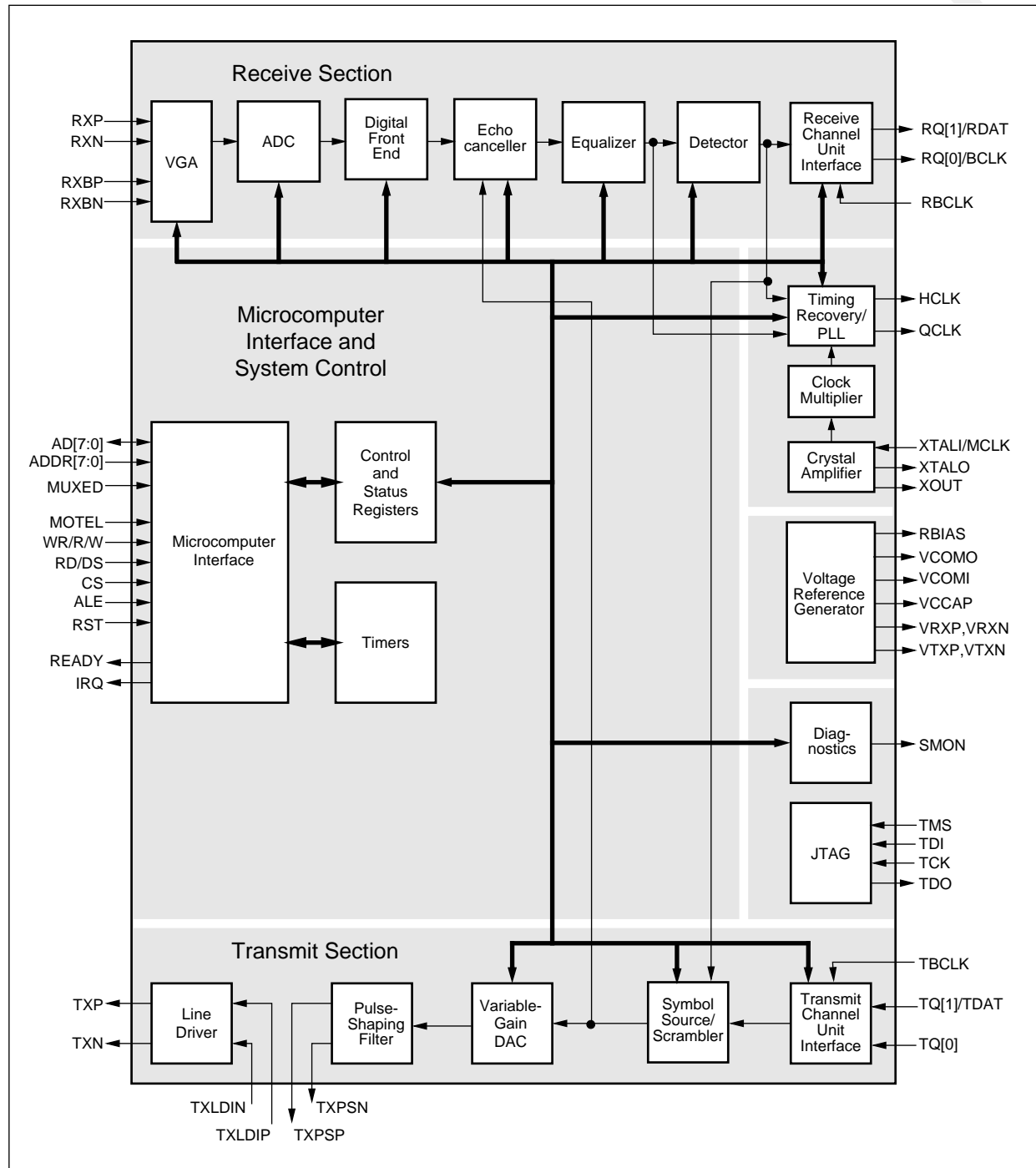

100101\_003

### 1.1.1 Transmit Section

The source of transmitted symbols is programmable through the microcomputer interface. The primary choices include external 2B1Q-encoded data presented to the TQ[1,0]/TDAT pins of the channel unit interface, internally looped-back receive symbols from the detector, or a constant “all ones” source. The symbols are then optionally scrambled. Isolated pulses can also be generated to support the testing of pulse templates.

The digital symbols are transformed to an analog signal via the DAC, which is highly linear in order to maximize the echo cancellation and detection properties of the signal. In addition, the transmit power level of the DAC may be adjusted via the Transmitter Gain Register [tx\_gain; 0x29] to optimize performance. The Transmitter Calibration Register [tx\_calibrate; 0x28] contains the nominal setting for the transmitter gain which is calibrated and hard-coded at the factory. The pulse-shaping filter then conditions the signal to prevent crosstalk to adjacent subscriber lines. Finally, the differential line driver provides the current driving capabilities and low-distortion characteristics needed to drive a large range of subscriber lines at low-bit error rates.

### 1.1.2 Receive Section

The differential Variable Gain Amplifier (VGA) receives the data from the subscriber line. Balancing inputs (RXBP, RXBN) are provided to accommodate first-order transmit echo cancellation via an external hybrid. The gain is programmable so that the dynamic range of the Analog-to-Digital Converter (ADC) can be maximized according to the attenuation of the subscriber line.

Digitized receive data is passed to the Digital Signal Processor (DSP) portion of the Bt8970. After DC offset cancellation, a replica of the transmit signal is subtracted from the total receive signal by a digital echo canceller. The resultant far-end signal is then conditioned by an equalization stage consisting of Automatic Gain Control (AGC), a feed-forward equalizer, a decision-feedback equalizer, and an error predictor. A mode-dependent detector is then used to recover the 2B1Q-encoded data from the equalized signal. The channel unit interface then provides an optional descrambling function followed by parallel or serial output of the sign and magnitude bits on pins RQ[1,0]/RDAT. A number of meters are implemented within the receiver to provide average level indications at various points in the receive signal path. The receive section also performs remote unit clock recovery through an on-chip Phase Lock Loop (PLL) circuit.

### 1.1.3 Timing Recovery and Clock Interface

The clock interface includes a crystal amplifier module to reduce the external components needed for clock generation. The crystal frequency must be 16 times the desired symbol rate. When configured as a remote unit, the PLL module recovers the incoming data clock and outputs it on the QCLK pin (and also the BCLK pin for serial mode operation). The HCLK output, which is synchronized to the QCLK signal, can be configured to cycle at 16, 32, or 64 times the symbol rate.

### 1.1.4 Microcomputer Interface

The Microcomputer Interface (MCI) provides access to a 256-byte address space within the transceiver. A combination of direct and indirect addressing methods are used to access all internal locations. The MCI is designed to interface with both Intel- and Motorola-style processors with no additional glue logic. A  $\overline{\text{MOTEL}}$  control pin is provided to configure the bus interface control/handshake lines to conform to common Motorola/Intel conventions. A  $\overline{\text{MUXED}}$  control pin is provided to configure the bus interface address and data lines for multiplexed or independent data/address bus operation. Little-endian data formatting (least significant byte of a multibyte word stored at the lowest byte-address location) is used in all cases, regardless of  $\overline{\text{MOTEL}}$  pin selection. A  $\overline{\text{READY}}$  control pin is provided to support wait-state insertion. An Interrupt Request (IRQ) output pin supports low-latency responses to time-critical events within the transceiver.

Eight 16-bit timers and ten measurement meters are integrated into the transceiver. The timers support various metering functions within the receiver section and off-load the external microcomputer from complex timing operations associated with startup procedures. Control and monitoring access to the timers and meters is provided through the microcomputer interface.

### 1.1.5 Test and Diagnostic Interface (JTAG)

The Test and Diagnostic Interface comprises a test access port and a Serial Monitor Output (SMON). The test access port conforms to IEEE Std 1149.1-1990, (IEEE Standard Test Access Port and Boundary Scan Architecture). Also referred to as Joint Test Action Group (JTAG), this interface provides direct serial access to each of the transceiver's I/O pins. This capability can be used during an in-circuit board test to increase the testability and reduce the cost of the in-circuit test process.

The serial monitor output can be viewed as a real-time virtual probe for looking at the transceiver's internal signals. The programmable signal source is shifted out serially at 16 times the symbol rate. The majority of the receive signal path is accessible through this output.

## 1.2 Pin Descriptions

The Bt8970 is packaged in a 100-Pin Plastic Quad Flat Pack (PQFP). The pin assignments are shown in Figure 1-3. A listing of pin labels, numbers, and I/O assignments is given in Table 1-1. Signal definitions are provided in Table 1-2. The coding used in the I/O column is: O = digital output, OA = analog output, OD = open-drain output, I = digital input, IA = analog input, and I/O = bidirectional.

Figure 1-3. Pin Diagram

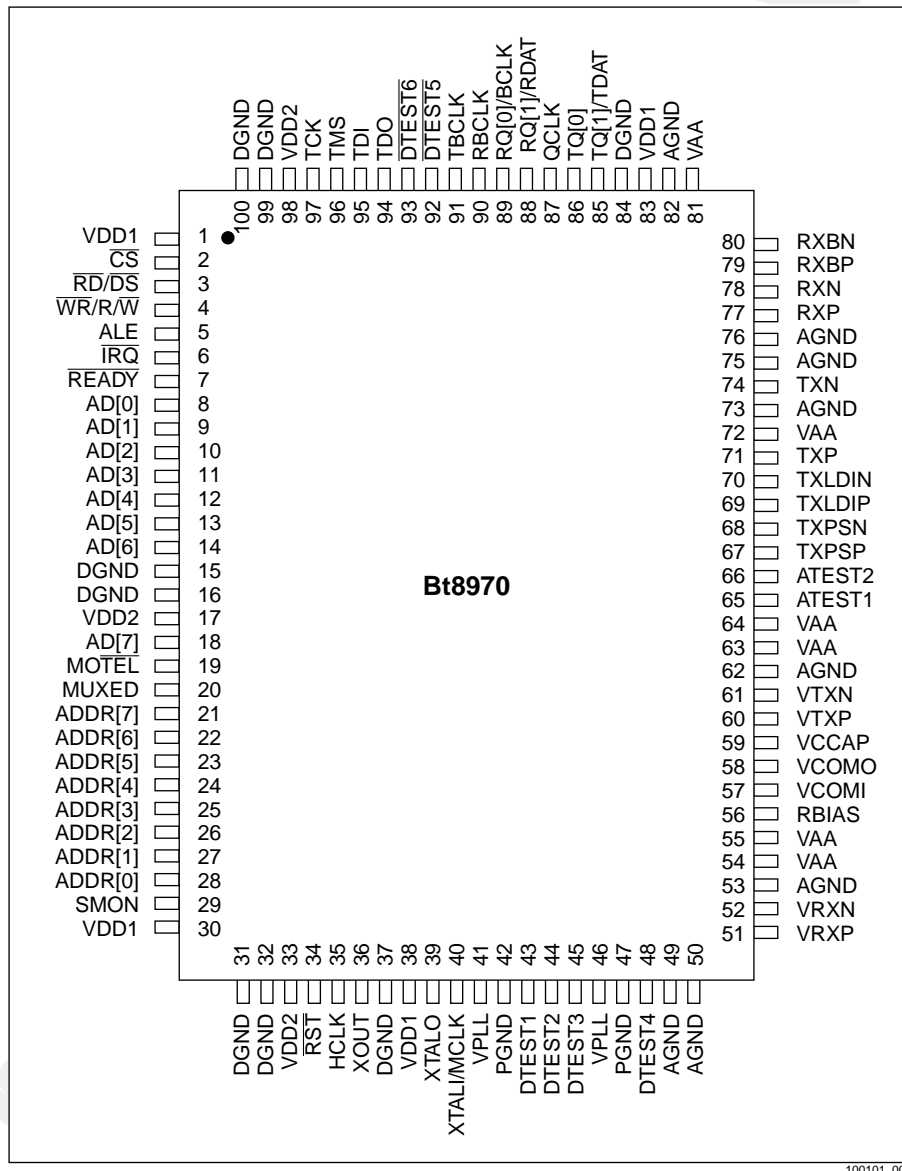

Table 1-1. Pin Descriptions

Pin	Pin Label	I/O	Pin	Pin Label	I/O	Pin	Pin Label	I/O	Pin	Pin Label	I/O
1	VDD1	–	26	ADDR[2]	I	51	VRXP	OA	76	AGND	–
2	CS	I	27	ADDR[1]	I	52	VRXN	OA	77	RXP	IA
3	RD/DS	I	28	ADDR[0]	I	53	AGND	–	78	RXN	IA
4	$\overline{WR/R\overline{W}}$	I	29	SMON	O	54	VAA	–	79	RXBP	IA
5	ALE	I	30	VDD1	–	55	VAA	–	80	RXBN	IA
6	I $\overline{RQ}$	OD	31	DGND	–	56	RBIAS	OA	81	VAA	–
7	READY	OD	32	DGND	–	57	VCOMI	OA	82	AGND	–
8	AD[0]	I/O	33	VDD2	–	58	VCOMO	OA	83	VDD1	–
9	AD[1]	I/O	34	RST	I	59	VCCAP	OA	84	DGND	–
10	AD[2]	I/O	35	HCLK	O	60	VTXP	OA	85	TQ[1]/TDAT	I
11	AD[3]	I/O	36	XOUT	O	61	VTXN	OA	86	TQ[0]	I
12	AD[4]	I/O	37	DGND	–	62	AGND	–	87	QCLK	O
13	AD[5]	I/O	38	VDD1	–	63	VAA	–	88	RQ[1]/RDAT	O
14	AD[6]	I/O	39	XTALO	O	64	VAA	–	89	RQ[0]/BCLK	O
15	DGND	–	40	XTALI/MCLK	I	65	ATEST1	IA	90	RBCLK	I
16	DGND	–	41	VPLL	–	66	ATEST2	IA	91	TBCLK	I
17	VDD2	–	42	PGND	–	67	TXPSP	OA	92	DTEST5	I
18	AD[7]	I/O	43	DTEST1	I	68	TXPSN	OA	93	DTEST6	I
19	$\overline{MOT\overline{EL}}$	I	44	DTEST2	I	69	TXLDIP	IA	94	TDO	O
20	MUXED	I	45	DTEST3	I	70	TXLDIN	IA	95	TDI	I
21	ADDR[7]	I	46	VPLL	–	71	TXP	OA	96	TMS	I
22	ADDR[6]	I	47	PGND	–	72	VAA	–	97	TCK	I
23	ADDR[5]	I	48	DTEST4	I	73	AGND	–	98	VDD2	–
24	ADDR[4]	I	49	AGND	–	74	TXN	OA	99	DGND	–
25	ADDR[3]	I	50	AGND	–	75	AGND	–	100	DGND	–

Table 1-2. Hardware Signal Definitions (1 of 4)

Pin Label	Signal Name	I/O	Definition
<b>Microcomputer Interface (MCI)</b>			
MOTEL	Motorola/Intel	I	Selects between Motorola and Intel handshake conventions for the $\overline{RD}/\overline{DS}$ and $\overline{WR}/R/\overline{W}$ signals. MOTEL = 1 for Motorola protocol: $\overline{DS}$ , $R/\overline{W}$ MOTEL = 0 for Intel protocol: $\overline{RD}$ , $\overline{WR}$
ALE	Address Latch Enable	I	Falling-edge-sensitive input. The value of AD[7:0] when MUXED = 1, or ADDR[7:0] when MUXED = 0, is internally latched on the falling edge of ALE.
CS	Chip Select	I	Active-low input used to enable read/write operations on the Microcomputer Interface (MCI).
$\overline{RD}/\overline{DS}$	$\overline{Read}/\overline{Data}$ Strobe	I	Bimodal input for controlling read/write access on the MCI. When MOTEL = 1 and $\overline{CS} = 0$ , $\overline{RD}/\overline{DS}$ behaves as an active-low data strobe $\overline{DS}$ . Internal data is output on AD[7:0] when $\overline{DS} = 0$ and $R/\overline{W} = 1$ . External data is internally latched from AD[7:0] on the rising edge of $\overline{DS}$ when $R/\overline{W} = 0$ . When MOTEL = 0 and $\overline{CS} = 0$ , $\overline{RD}/\overline{DS}$ behaves as an active-low read strobe $\overline{RD}$ . Internal data is output on AD[7:0] when $\overline{RD} = 0$ . Write operations are not controlled by $\overline{RD}$ in this mode.
$\overline{WR}/R/\overline{W}$	$\overline{Write}/\overline{Read}/\overline{Write}$	I	Bimodal input for controlling read/write access on the MCI. When MOTEL = 1 and $\overline{CS} = 0$ , $\overline{WR}/R/\overline{W}$ behaves as a read/write select line $R/\overline{W}$ . Internal data is output on AD[7:0] when $\overline{DS} = 0$ and $R/\overline{W} = 1$ . External data is internally latched from AD[7:0] on the rising edge of $\overline{DS}$ when $R/\overline{W} = 0$ . When MOTEL = 0 and $\overline{CS} = 0$ , $\overline{WR}/R/\overline{W}$ behaves as an active-low write strobe $\overline{WR}$ . External data is internally latched from AD[7:0] on the rising edge of $\overline{WR}$ . Read operations are not controlled by $\overline{WR}$ in this mode.
AD[7:0]	Address-Data[7:0]	I/O	8-bit bidirectional multiplexed address-data bus. AD[7] = MSB, AD[0] = LSB. Usage is controlled using the MUXED.
ADDR[7:0]	Address Bus (not multiplexed)[7:0]	I	Provides a glueless interface to microcomputers with separate address and data buses. ADDR[7] = MSB, ADDR[0] = LSB. Usage is controlled using the MUXED.
MUXED	Addressing Mode Select	I	Controls the MCI addressing mode. When MUXED = 1, the MCI uses AD[7:0] as a multiplexed signal for address and data (typical of Intel processors). When MUXED = 0, the MCI uses ADDR[7:0] as the address input, and AD[7:0] for data only (typical of Motorola processors).
READY	Ready	OD	Active-low, open-drain output that indicates that the MCI is ready to transfer data. Can be used to signal the microcomputer to insert wait states.
IRQ	Interrupt Request	OD	Active-low, open-drain output that indicates requests for interrupt. Asserted whenever at least one unmasked interrupt flag is set. Remains inactive whenever no unmasked interrupt flags are present.
RST	Reset	I	Asynchronous, active-low, level-sensitive input that places the transceiver in an inactive state by setting the power-down mode bit of the Global Modes and Status Register [global_modes; 0x00], and zeroing the clk_freq[1,0] bits of the PLL Modes Register [pll_modes; 0x22] and the hclk_freq[1,0] bits of the Serial Monitor Source Select Register [serial_monitor_source; 0x01]. All RAM contents are lost. Does not affect the state of the test access port which is reset automatically at power-up only.

Table 1-2. Hardware Signal Definitions (2 of 4)

Pin Label	Signal Name	I/O	Definition
<b>Channel Unit Interface</b>			
RQ[1]/ RDAT	Receive Quat 1/ Receive Data	0	RQ[1]/RDAT and RQ[0]/BCLK are bimodal outputs that represent the sign and magnitude bits of the received quaternary output symbol in parallel channel unit modes (RQ[1], RQ[0]), and the serial-data and bit-clock outputs in serial channel unit modes (RDAT, BCLK). Behavior of these outputs is configurable through the Channel Unit Interface Modes Register [CU_interface_modes; 0x06] for parallel master, parallel slave, serial magnitude-bit-first and serial sign-bit-first operations. For parallel mode operation:  RQ[1] = Sign bit output RQ[0] = Magnitude bit output  Both outputs are updated at the symbol rate on the rising edge of QCLK (master mode) or the rising/falling edge (programmable) of RBCLK (slave mode). For serial mode operation:  RDAT = Serial quaternary data output BCLK = Bit-rate (two times symbol rate) clock output RDAT is updated at the bit rate on the rising edge of BCLK
RQ[0]/ BCLK	Receive Quat 0/ Bit Clock	0	
TQ[1]/ TDAT	Transmit Quat 1/ Transmit Data	I	TQ[1]/TDAT and TQ[0] are bimodal inputs that represent the sign and magnitude bits of the quaternary input symbol to be transmitted in parallel channel unit modes (TQ[1], TQ[0]), and the serial data input in serial channel unit modes (TDAT). Interpretation of these inputs is configurable through the Channel Unit Interface Modes Register [CU_Interface_modes; 0x06] for parallel master, parallel slave, serial magnitude-bit-first and serial sign-bit-first operations. For parallel mode operation:  TQ[1] = Sign bit input TQ[0] = Magnitude bit input  Both inputs are sampled at the symbol rate on the falling edge of QCLK (master mode) or the rising/falling edge (programmable) of TBCLK (slave mode). For serial mode operation:  TDAT = Serial quaternary data input TQ0 = Don't care (tie or pull up to supply rail)  TDAT is sampled at the bit rate (two times the symbol rate) on the falling edge of BCLK.
TQ[0]	Transmit Quat 0	I	
QCLK	Quaternary Clock	0	Runs at the symbol rate. It defines the data on the TQ and RQ interfaces. QCLK is also used to frame transmit/receive quats in serial mode.
TBCLK	Transmit Baud-Rate Clock	I	Functions as the transmit baud-rate clock input. It must be frequency locked to QCLK. This input is used only when the channel unit interface is in parallel slave mode. If it is unused, it should be tied to VDD2 or DGND.
RBCLK	Receive Baud-Rate Clock	I	Functions as the receive baud-rate clock input. It must be frequency locked to QCLK. This input is used only when the channel unit interface is in parallel slave mode. If it is unused, it should be tied to VDD2 or DGND.

Table 1-2. Hardware Signal Definitions (3 of 4)

Pin Label	Signal Name	I/O	Definition
<b>Analog Transmit Interface</b>			
TXP, TXN	Transmit Positive, Negative	OA	Differential Transmit Line Driver Outputs. These signals are used to drive the subscriber line after passing through the hybrid and line transformer.
TXLDIP, TXLDIN	Transmit Line Driver In Positive, Negative	IA	Differential Transmit Line Driver Inputs. These inputs should be connected to the TXPSP, TXPSN outputs after passing through an external RC filter.
TXPSP, TXPSN	Transmit Pulse-Shaping Filter Positive, Negative	OA	Differential Transmit Pulse-Shaping Filter Outputs. These outputs should be connected to an external RC filter, which is then connected to the TXLDIP and TXLDIN inputs.
<b>Analog Receive Interface</b>			
RXP, RXN	Receive Positive, Negative	IA	Differential Receiver Inputs. RXP and RXN receive the signal from the subscriber line.
RXBP, RXBN	Receive Balance Positive, Negative	IA	Differential Receiver Balance Inputs. RXBP and RXBN are used to subtract the echo of the signal being transmitted on the subscriber line. They should be connected to the TXP, TXN output pins through the hybrid circuit. This signal is subtracted from the signal being received by the RXP and RXN inputs in the Variable Gain Amplifier (VGA).
<b>Voltage Reference Generator Interface</b>			
RBIAS	Resistor Bias	OA	Connection point for external bias resistor.
VCOMO	Common Mode Voltage Outputs	OA	Common mode voltage for the analog circuitry. This pin should be connected to an external filtering capacitor.
VCOMI	Common Mode Voltage Inputs	OA	Common mode voltage for the analog circuitry. This pin should be connected to an external filtering capacitor.
VCCAP	Voltage Compensation Capacitor	OA	Analog Voltage Compensation Capacitor. This pin should be connected to an external filtering capacitor.
VRXP, VRXN	Receiver Voltage Reference Positive, Negative	OA	Analog Receive Circuitry Reference Voltages. These pins should be connected to external filtering capacitors.
VTXP, VTXN	Transmit Voltage Reference Positive, Negative	OA	Analog Transmit Circuitry Reference Voltages. These pins should be connected to external filtering capacitors.
<b>Clock Interface</b>			
XTALI/MCLK	Crystal In/Master Clock	I	A bimodal input that can be used as the crystal input or as the master clock input. If an external clock is connected to this input, XTALO should be left floating. The frequency of the crystal or clock should be 16 times the symbol rate (8 times the data rate).
XTALO	Crystal Output	O	Connection point for the crystal.
HCLK	High Speed Clock Out	O	HCLK can be configured to run at 16, 32, or 64 times the symbol rate. Upon reset, it is set to 16 times the symbol rate. This clock will be phase locked to the incoming data when the Bt8970 is configured as the remote unit.
XOUT	Crystal Clock Out	O	Buffered-crystal oscillator output.

11/29/00 10:00 A.M.

Table 1-2. Hardware Signal Definitions (4 of 4)

Pin Label	Signal Name	I/O	Definition
<b>Test and Diagnostic Interface</b>			
TDI	JTAG Test Data Input	I	JTAG test data input per IEEE Std 1149.1-1990. Used for loading all serial instructions and data into internal test logic. Sampled on the rising edge of TCK. TDI can be left unconnected if it is not being used because it is pulled-up internally.
TMS	JTAG Test Mode Select	I	JTAG test mode select input per IEEE Std 1149.1-1990. Internally pulled-up input signal used to control the test-logic state machine. Sampled on the rising edge of TCK. TMS can be left unconnected if it is not being used because it is pulled-up internally.
TDO	JTAG Test Data Output	O	JTAG test data output per IEEE Std 1149.1-1990. Three-state output used for reading all serial configuration and test data from internal test logic. Updated on the falling edge of TCK.
TCK	JTAG Test Clock Input	I	JTAG test clock input per IEEE Std 1149.1-1990. Used for all test interface and internal test logic operations. If unused, TCK should be pulled low.
SMON	Serial Monitor	O	Serial data output used for real-time monitoring of internal signal-path registers. The source register is selected through the Serial Monitor Source Select Register [serial_monitor_source; 0x01]. 16-bit words are shifted out, LSB first, at 16 times the symbol rate. The rising edge of QCLK defines the start Least Significant Bit (LSB) of each word. The output is updated on the rising edge of an internal clock running at 16 times QCLK.
DTEST[1:4]	Digital Tests 1–4	I	Active-high test inputs used by Rockwell to enable internal test modes. These inputs should be tied to Digital Ground (DGND).
DTEST[5, 6]	Digital Test 5, 6	I	Active-low test inputs used by Rockwell to enable internal test modes. These inputs should be tied to the I/O buffer power supply (VDD2).
ATEST[1,2]	Analog Test 1, 2	IA	Analog test inputs used by Rockwell for internal test modes. These inputs should be left floating (No Connect, NC).
<b>Power and Ground</b>			
VDD1	Core Logic Power Supply	–	Dedicated supply pins powering the digital core logic functions. Can be connected to +5 V or 3.3 V.
VDD2	I/O Buffer Power Supply	–	Dedicated supply pins powering the digital I/O buffers.
VPLL	PLL Power Supply	–	Dedicated supply pins powering the PLL and the crystal amplifier.
PGND	PLL Ground	–	Dedicated ground pins for the PLL and the crystal amplifier. Must be held at the same potential as DGND and AGND.
DGND	Digital Ground	–	Dedicated ground pins for the digital circuitry. Must be held at same potential as AGND and PGND.
VAA	Analog Power Supply	–	Dedicated supply pins powering the analog circuitry.
AGND	Analog Ground	–	Dedicated ground pins for the analog circuitry. Must be held at the same potential as DGND and PGND.

## 2.0 Functional Description

### 2.1 Transmit Section

The transmit section is illustrated in [Figure 2-1](#). It comprises four major functions: a symbol source selector/scrambler, a variable gain digital-to-analog converter (DAC), a pulse-shaping filter, and a line driver.

Figure 2-1. Transmit Section Block Diagram

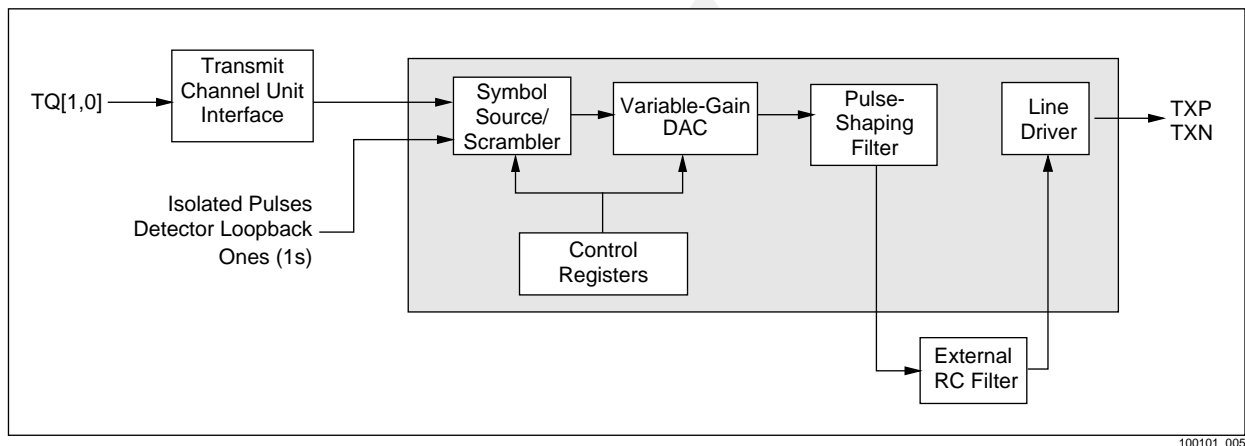

#### 2.1.1 Symbol Source Selector/Scrambler

The input source selector/scrambler can be configured through the Transmitter Modes Register [transmitter\_modes; 0x0B] data\_source [2:0] bits to select the source of the data to be transmitted and determine whether or not the data is scrambled. The symbol source selector/scrambler modes are specified in [Table 2-1](#).

Table 2-1. Symbol Source Selector/Scrambler Modes

data_source[2:0]	Symbol Source Selector/Scrambler Mode
000	Isolated pulse. Level selected by isolated_pulse[1,0]. The meter timer must be enabled and in the continuous mode. The pulse repetition interval is determined by the meter-timer-countdown interval.
001	Four-level scrambled detector loopback. Sign and magnitude bits from the receiver detector are scrambled and looped back to the transmitter. Feedback polynomial determined by the htur_lfsr control bit.
010	Four-level unscrambled data. Transmits the four-level (2B1Q) sign and magnitude bits from the transmit channel unit.
011	Four-level scrambled ones. Transmits a scrambled, constant high-logic level as a four-level (2B1Q) signal. Feedback polynomial determined by the htur_lfsr control bit.
100	Reserved.
101	Four-level scrambled data. Scrambles and transmits the four-level (2B1Q) sign and magnitude bits from the channel unit transmit interface. Feedback polynomial determined by the htur_lfsr control bit.
110	Two-level unscrambled data. Constantly forces the magnitude bit from the transmit channel unit interface to a logic zero, and transmits the resulting two-level signal (as determined by the sign bit) without scrambling. Valid output levels limited to +3, -3.
111	Two-level scrambled ones. Transmits a scrambled, constant high-logic level, as a two-level signal. Feedback polynomial determined by the htur_lfsr control bit. Scrambler is run at the symbol rate (half-bit rate) to produce the sign bit of the transmitted signal while the magnitude bit is sourced with a constant logic zero. Valid output levels limited to +3, -3.

The bit stream is converted into symbols for the four-level cases as shown in [Table 2-2](#).

Table 2-2. Four-Level Bit-to-Symbol Conversions

First Input Bit (sign)	Second Input Bit (magnitude)	Output Symbol
0	0	-3
0	1	-1
1	1	+1
1	0	+3

In two-level mode, the magnitude bit is forced to a zero. This forces the symbols to be +3 and -3, as shown in [Table 2-3](#).

Table 2-3. Two-Level Bit-to-Symbol Conversions

First Input Bit (sign)	Second Input Bit (magnitude)	Output Symbol
0	don't care	-3
1	don't care	+3

The scrambler is essentially a 23-bit-long Linear Feedback Shift Register (LFSR). The feedback points are programmable for central office and remote terminal applications using the `htur_lfsr` bit of the Transmitter Modes Register. The LFSR polynomials for local (HTU-C/LTU) and remote (HTU-R/NTU) unit operations are:

$$\begin{aligned} \text{local} &\Rightarrow x^{-23} \oplus x^{-5} \oplus 1 \\ \text{remote} &\Rightarrow x^{-23} \oplus x^{-18} \oplus 1 \end{aligned}$$

The scrambler operates differently depending on whether a two-level or four-level mode is specified. In two-level scrambled-ones mode, the LFSR is clocked once-per-symbol; in four-level mode, the LFSR is clocked twice-per-symbol.

The Transmitter Modes Register can also be used to zero the output of the transmitter using the `transmitter_off` control bit.

The Bt8970 can generate isolated pulses to support the testing of pulse templates. When in the isolated pulse mode, the output consists of a single pulse surrounded by zeros.

**NOTE:** Zero is not a valid 2B1Q level and only occurs in this special mode or when the transmitter is off. The repetition rate of the pulses is controlled by the meter timer. Any of the four 2B1Q levels may be chosen via the Transmitter Modes Register's `isolated_pulse[1,0]` control bits.

### 2.1.2 Variable Gain Digital-to-Analog Converter

A four-level Digital-to-Analog Converter (DAC) is integrated into the Bt8970 to accurately convert the output of the symbol source to analog form. The normalized values of these four analog levels are: +3, +1, -1 and -3. Each represents a symbol or quat.

To provide precise adjustment of the transmitted power, the level of the DAC may be adjusted. The Transmitter Gain Register [`tx_gain`; 0x29] sets the level.

During the manufacturing of the Bt8970, one source of variation in the transmitter levels is process variations. The Transmitter Calibration Register [`tx_calibrate`; 0x28] contains a read-only value which nulls this variation. The value of this register is determined for each Bt8970 device during production testing. Upon initialization, the Transmitter Gain Register should be loaded based on the transmitter calibration register.

If there are other sources of transmit power variation (e.g., a nonstandard hybrid or attenuative lightning protection), the transmitter gain must be adjusted to include these affects.

### 2.1.3 Pulse-Shaping Filter

The pulse-shaping filter filters the quats output from the variable-gain DAC. This filter, when combined with other filtering in the signal path, produces a transmitted signal on the line that meets the power spectral density, transmitted power, and pulse-shaping requirements, as specified in the Electrical Specifications section of this datasheet.

### 2.1.4 Line Driver

The line driver buffers the output of the pulse-shaping filter to drive diverse loads. The output of the line driver is differential.

11/29/00 10:00 A.M.

## 2.2 Receive Section

Like the transmit section, the receive section consists of both analog and digital circuitry. The Variable Gain Amplifier (VGA) provides the interface to the analog signals received from the line and the hybrid. The Analog-to-Digital Converter (ADC) then digitizes the analog signal so it can be further processed in the Digital Signal Processing (DSP) section of the receiver. The receiver DSP section includes: front-end processing, echo cancellation, and symbol detection.

### 2.2.1 Variable Gain Amplifier

The Variable Gain Amplifier (VGA) has two purposes. The first is to provide a dual-differential analog input so the pseudo-transmit signal created by the hybrid can be subtracted from the signal from the line transformer. This subtraction provides first-order echo cancellation, which results in a first-order approximation of the signal received from the line. [Figure 2-2](#) illustrates the recommended echo-cancellation circuit interconnections. All off-chip circuitry, including the hybrid and anti-alias filters, consists entirely of passive components. Further echo cancellation occurs in the receiver DSP.

Figure 2-2. First-Order Echo Cancellation Using the Variable Gain Amplifier

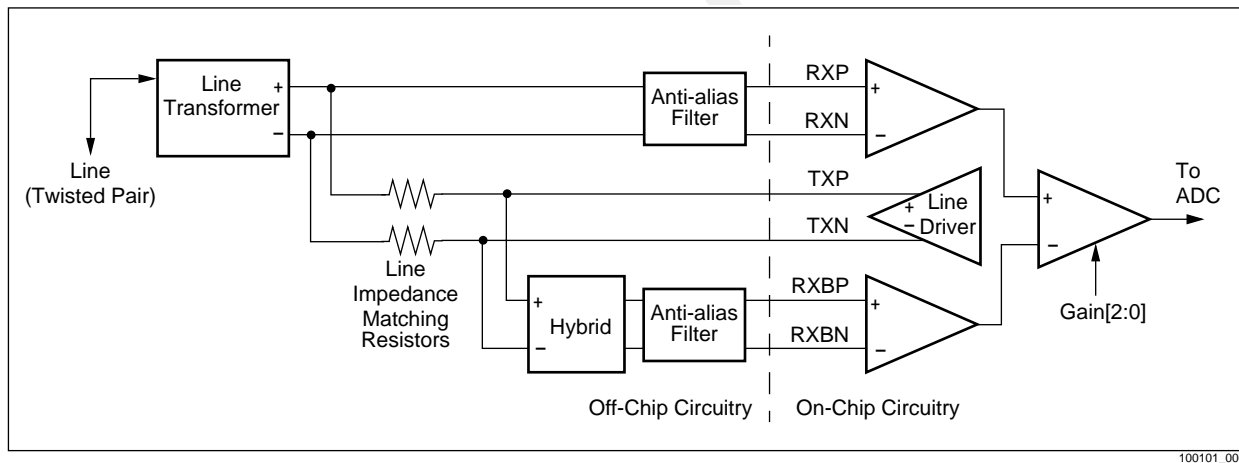

The second purpose of the VGA is to provide programmable gain of the received signal prior to passing it to the ADC. This reduces the resolution required for the ADC. There are six gain settings ranging from 0 dB to 15 dB. The gain is controlled via the gain[2:0] control bits in the ADC Control Register [adc\_control; 0x21]. See the Registers section of this datasheet for a more detailed description of the gain[2:0] control bits.

### 2.2.2 Analog-to-Digital Converter

The Analog-to-Digital Converter (ADC) provides 16 bits of resolution. The analog input from the variable gain amplifier is converted into digital data and output at the symbol rate.

### 2.2.3 Digital Signal Processor

The Digital Signal Processor (DSP) includes five Least Mean Squared (LMS) filters: an Echo Cancellor (EC), a Digital Automatic Gain Controller (DAGC), a Feed Forward Equalizer (FFE), an Error Predictor (EP), and a Decision Feedback Equalizer (DFE). These filters are used to equalize the received signal so that the symbols transmitted from the far-end can be reliably recovered. The DSP uses symbol rate sampling for all processing functions. Their interconnections and relationships to the digital front-end and the detector are illustrated in Figure 2-3.

Figure 2-3. Receiver Digital Signal Processing

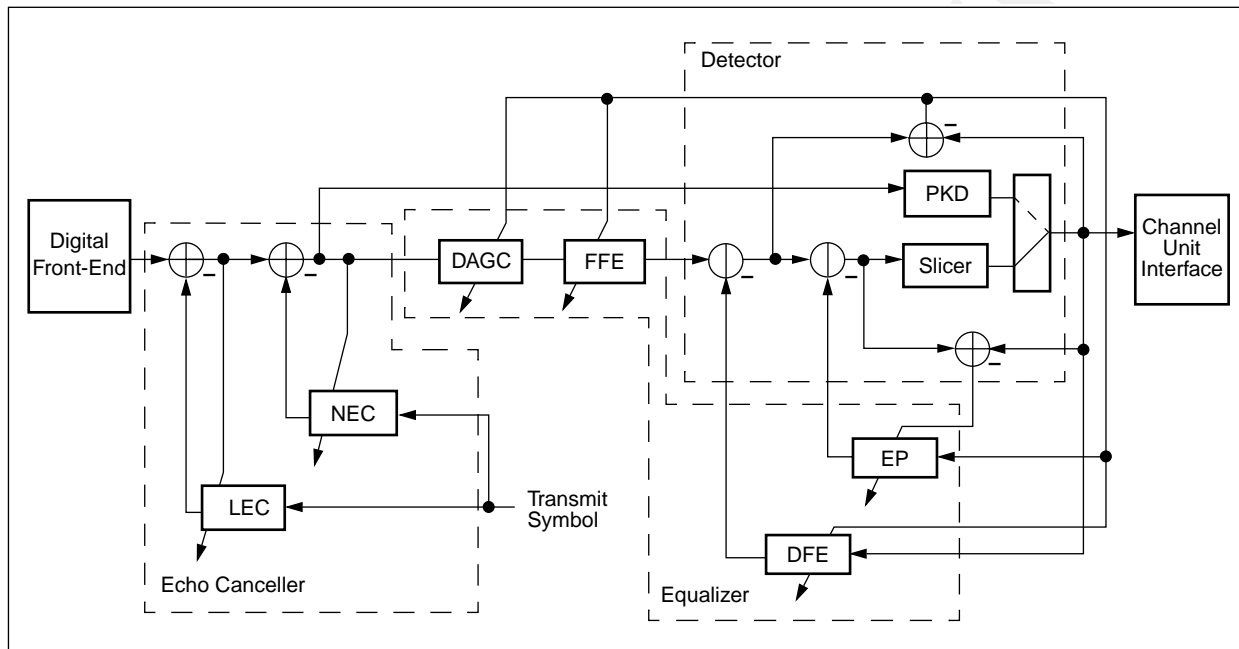

100101\_007

11/29/00 10:00 A.M.

2.2.3.1 Digital Front-End

Prior to the main signal processing, the input signal must be adjusted for any DC offset. The front-end module also monitors the input signal level, which includes measuring DC and AC input signal levels, detecting and counting overflows, and detecting alarms based on the far-end signal level. Figure 2-4 summarizes the features of the digital front-end module.

Figure 2-4. Digital Front-End Block Diagram

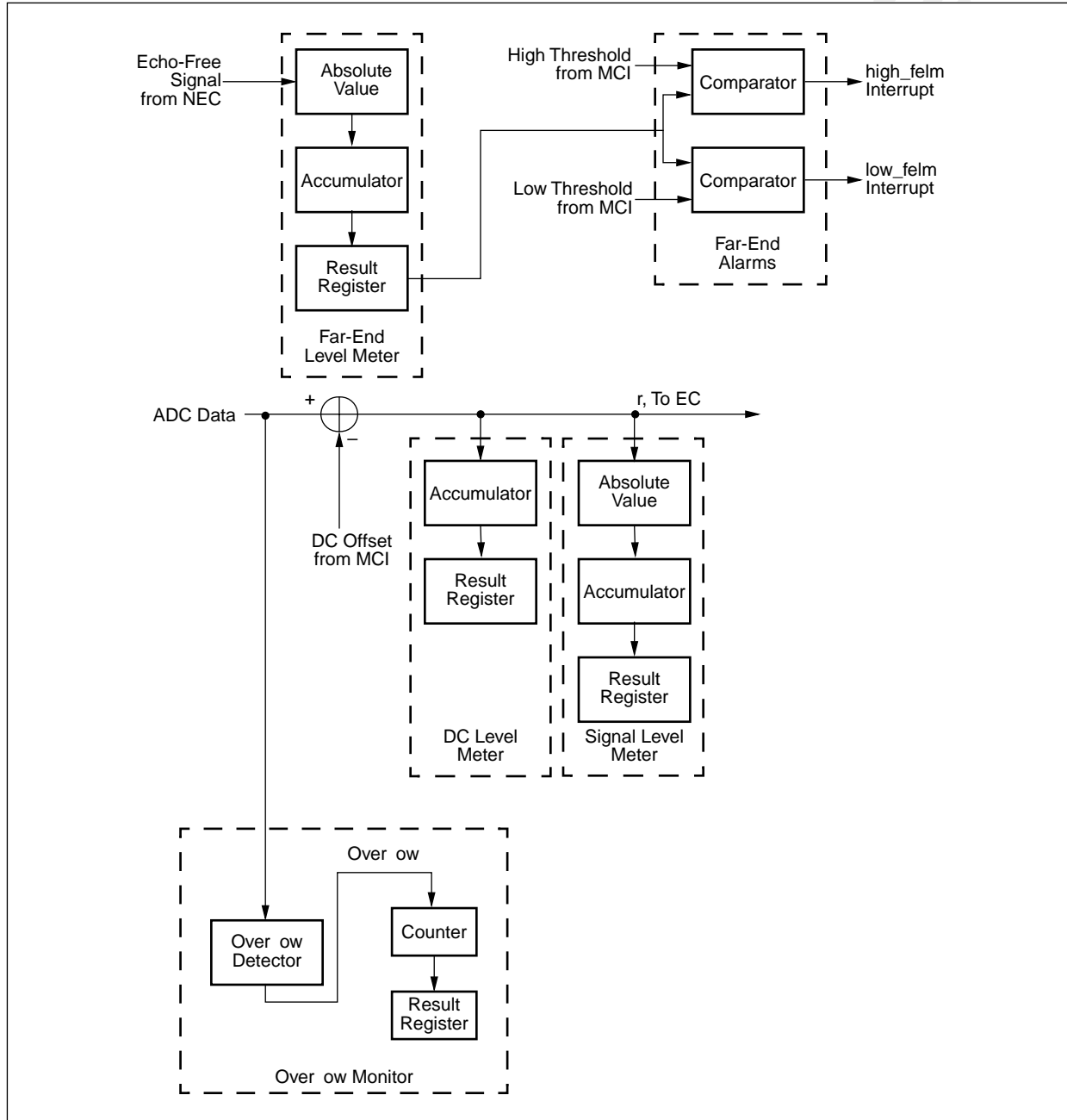

11/29/00 10:00 A.M.

### 2.2.3.2 Offset Adjustment

A nonzero DC level on the input can be corrected by a DC offset value [dc\_offset\_low, dc\_offset\_high; 0x26, 0x27] which is subtracted from the input. The DC offset is a 16-bit number and is programmed via the microcomputer interface.

### 2.2.3.3 DC Level Meter

The DC level meter provides the monitoring needed for adaptive offset compensation. The offset-adjusted input signal is accumulated over the meter timer interval [meter\_low, meter\_high; 0x18, 0x19]. The 16 MSBs are placed into the DC Level Meter Registers [dc\_meter\_low, dc\_meter\_high; 0x44, 0x45].

### 2.2.3.4 Signal Level Meter

The signal level meter provides the monitoring needed for adjusting the analog gain circuit located prior to the ADC. This value is accumulated over the meter timer interval [meter\_low, meter\_high; 0x18, 0x19]. The 16 MSBs are placed in the Signal Level Meter Registers [slm\_low, slm\_high; 1; 0x46, 0x47].

### 2.2.3.5 Overflow Detection and Monitoring

The overflow sensor detects ADC overflows. The overflow monitor counts the number of overflows, as indicated by the overflow sensor during the meter timer interval [meter\_low, meter\_high; 0x18, 0x19]. The counter is limited to 8 bits. In the case of 256 or more overflows during the measurement interval, the counter will hold at 255. The counter is loaded into the Overflow Meter Register [overflow\_meter; 0x42] at the end of each measurement interval.

### 2.2.3.6 Far-End Level Meter

The far-end level meter monitors the output of the echo canceller. Since the echo canceller output had the echo of the transmitted signal subtracted from it, it is called the far-end signal. This value is accumulated over the meter timer interval [meter\_low, meter\_high; 0x18, 0x19]. The 16 MSBs are placed into the Far-End Level Meter Register [felm\_low, felm\_high; 0x48, 0x49].

### 2.2.3.7 Far-End Level Alarm

The result of the far-end level meter is compared to two thresholds. When exceeded, an interrupt is sent to the microcomputer interface, if enabled. The threshold is determined by the value in the Far-End High Alarm Threshold Registers [far\_end\_high\_alarm\_th\_low, far\_end\_high\_alarm\_th\_high; 0x30, 0x31] and the Far-End Low Alarm Threshold Registers [far\_end\_low\_alarm\_th\_low, far\_end\_low\_alarm\_th\_high; 0x32, 0x33].

The interrupts high\_felm and low\_felm, are bits 2 and 1, respectively of the IRQ Source Register [irq\_source; 0x05]. The interrupts high\_felm and low\_felm, can be masked by writing a one to bits 2 and 1, respectively of the Interrupt Mask Register High [mask\_high\_reg; 0x03].

## 2.2.4 Echo Canceller

The Echo Canceller (EC) removes images of the transmitted symbols from the received signal and consists of two blocks: a linear and nonlinear echo canceller. The organization of the blocks is displayed in [Figure 2-3](#).

### 2.2.4.1 Linear Echo Canceller (LEC)

The Linear Echo Canceller (LEC) is a conventional LMS, Finite Impulse Response (FIR) filter, which removes linear images of the transmitted symbols from the received signal. It consists of a 60-tap FIR filter with 32-bit linear adapted coefficients.

When enabled, the last data tap of the echo canceller is treated specially. This serves to cancel any DC offset that may be present.

A freeze coefficient mode may be specified via the microcomputer interface. This mode disables the coefficient updates only. A special mode exists to zero all of the coefficients; it is also enabled through the microcomputer interface.

An additional mode exists to zero the output of the FIR with no effect on the coefficients; it is also enabled through the microcomputer interface. Individual EC coefficients can be read and written through the microcomputer interface. Adaptation should be frozen prior to reading or writing coefficients.

### 2.2.4.2 Nonlinear Echo Canceller (NEC)

The Nonlinear Echo Canceller (NEC) reduces the residual echo power in the echo canceller output caused by nonlinear effects in the transmitter DAC, receiver ADC, analog hybrid circuitry, or line cables.

The delay of the transmit-symbol input to the NEC can be specified via the microcomputer interface, Nonlinear Echo Canceller Mode Register [nonlinear\_ec\_modes; 0x09]. This allows the NEC to operate on the peak of the echo regardless of differing delays in the echo path.

A freeze coefficient mode may be specified via the microcomputer interface. This mode disables the coefficient updates only. A special mode exists to zero all of the coefficients; it is also enabled through the microcomputer interface.

An additional mode exists to zero the output of the look-up table with no effect on the coefficients. It is also enabled through the microcomputer interface. The 64, 14-bit, individual NEC coefficients can be read and written through the microcomputer interface. Adaptation should be frozen prior to reading or writing coefficients.

## 2.2.5 Equalizer

Four LMS filters are used in the equalizer to process the echo canceller output so that received symbols can be reliably recovered. The filters are a digital automatic gain controller, a feed forward equalizer, an error predictor, and a decision feedback equalizer. Their interconnections are shown in [Figure 2-3](#).

### 2.2.5.1 Digital Automatic Gain Control (DAGC)

The Digital Automatic Gain Control (DAGC) scales the echo-free signal to the optimum magnitude for subsequent processing. Its structure is that of an LMS filter, but it is a degenerate case because there is only one tap.

A freeze coefficient mode may be specified via the microcomputer interface. This mode disables the coefficient update only.

The DAGC gain coefficient can be read or written through the microcomputer interface. Adaptation should be frozen prior to reading or writing the coefficient.

### 2.2.5.2 Feed Forward Equalizer (FFE)

The Feed Forward Equalizer (FFE) removes precursors from the received signal. The FFE may be operated in a special *adapt last* mode. In this mode, which is useful during startup, only the last coefficient is updated. The last coefficient is the one which is multiplied with the oldest data sample (sample #7).

A freeze coefficient mode may be specified via the microcomputer interface. This mode disables the coefficient updates only. A special mode exists to zero all of the coefficients; it is also enabled through the microcomputer interface. Individual FFE coefficients can be read and written through the microcomputer interface. Adaptation should be frozen prior to reading or writing coefficients.

### 2.2.5.3 Error Predictor (EP)

The Error Predictor (EP) improves the performance of the equalizer by prognosticating errors before they occur. A freeze coefficient mode may be specified via the microcomputer interface. This mode disables the coefficient updates only. A special mode exists to zero all of the coefficients; it is also enabled through the microcomputer interface. Individual EP coefficients can be read and written through the microcomputer interface. Adaptation should be frozen prior to reading or writing coefficients.

### 2.2.5.4 Decision Feedback Equalizer (DFE)

The Decision Feedback Equalizer (DFE) removes postcursors from the received signal. A freeze coefficient mode may be specified via the microcomputer interface. This mode disables the coefficient updates only. A zero coefficients mode exists to zero all of the coefficients; it is also enabled through the microcomputer interface. A zero filter output mode exists to zero the output of the FIR with no effect on the coefficients. It is also enabled through the microcomputer interface. Individual DFE coefficients can be read and written through the microcomputer interface. Adaptation should be frozen prior to reading or writing coefficients.

### 2.2.5.5 Microcoding

The DAGC, FFE, and EP filters are implemented using an internal microprogrammable Digital Signal Processor (DSP) optimized for LMS filters. Internal DSP micro-instructions are stored in an on-chip RAM. This microcode RAM is loaded after powerup through the microcomputer interface when the transceiver is initialized.

## 2.2.6 Detector

The detector converts the equalized received signal into a 2B1Q symbol and produces two error signals used in adapting the receiver equalizers. The signal detection uses two sub-blocks, a slicer, and a peak detector. Additionally, the detector contains a scrambler and Bit Error Rate (BER) meter for use during the startup sequence.

### 2.2.6.1 Slicer

The slicer thresholds the equalized signal to produce a 2B1Q symbol. The input to the slicer is the FFE output minus the DFE and EP outputs.

The slicer can operate in two modes: two-level and four-level. In the two-level mode, used during the part of startup when the only transmitted symbols are +3 or -3, the slicer threshold is set at zero.

When in four-level mode, the cursor level is specified via the microcomputer interface. It is a 16-bit, 2s complement number, but must be positive and less than 0x2AAA for proper operation.

### 2.2.6.2 Peak Detector (PKD)

The PKD is only used during the two-level transmission part of startup. It operates on the echo-free signal. A signal is detected to be a +3 if it is higher than both of its neighbors, or a -3 if it is lower than both of its neighbors. If neither of the peaked conditions exist, the output of the slicer is used.

### 2.2.6.3 Error Signals

The detector computes two error signals for use in the equalizer: a 16-bit slicer and a 16-bit equalizer.

### 2.2.6.4 Scrambler Module

The scrambler may operate as either a scrambler or as a descrambler. The scrambler block is used during the scrambled-ones part of the startup sequence. This provides an error-free signal for equalizer adaptation. This scrambler is essentially a 23-bit-long Linear Feedback Shift Register (LFSR) with feedback. The feedback point depends on whether the transceiver is being used in a central-office or remote-terminal application.

When operating as a descrambler, the input source is the detector output. The symbol is converted to a bit stream, as shown in [Table 2-4](#) for the two-level case.

**Table 2-4. Two-Level Symbol-to-Bit Conversion**

Input Symbol	Output Bit
-3	0
+3	1

The symbol is converted to a bit stream, as shown in Table 2-5 for the four-level case.

Table 2-5. Four-Level Symbol-to-Bit Conversion

Input Symbol	First Output Bit (sign)	Second Output Bit (magnitude)
-3	0	0
-1	0	1
+1	1	1
+3	1	0

The LFSR operates in the same way in both cases, except in the two-level case it is clocked once-per-symbol and in the four-level case it is clocked twice-per-symbol.

When operating as a scrambler, the LFSR must first be locked to the far-end source. Once locked, it is then able to replicate the far-end input sequence, when its input is held at all ones. The locking sequence is controlled internally, initiated through the microcomputer interface by setting the `lfsr_lock` bit of the `detector_modes` register. The locking sequence consists of the following four steps:

1. Operate the LFSR as a *descrambler* for 23 bits.
2. Operate the LFSR as a *scrambler* for 127 bits. The sync detector is active during this period.
3. Go to Step 1 if synchronization was not achieved, otherwise continue to Step 4.
4. Send an interrupt to the microcomputer if unmasked, indicating successful locking and continue operating as a scrambler.

The sequence continues until the `lfsr_lock` control bit is cleared by the microcomputer.

#### 2.2.6.5 Sync Detector

The sync detector compares the output of the scrambler with the output of the symbol detector. The number of equivalent bits is accumulated for 128 comparisons. The result is then compared to a Scrambler Synchronization Threshold Register [`scr_sync_th`; 0x2E], lock is declared, and the sync bit of the `irq_source` register is set if the count is greater than the threshold. For a count less than or equal to the threshold, no lock condition is declared and the sync bit is unaffected.

#### 2.2.6.6 Detector Meters

The detector consists of five meters: a BER meter, a symbol histogrammer, a noise-level meter, a noise-level histogram meter, and an SNR alarm meter.

The BER meter provides an estimate of the bit error rate when the received symbols are known to be scrambled ones. When the LFSR is operating as a descrambler, the meter counts the number of ones on the descrambler output. When the LFSR is operating as a scrambler, the BER meter counts the number of equal scrambler and symbol detector outputs. The counter operates over the meter timer interval [`meter_low`, `meter_high`; 0x18, 0x19]. The counter is saturated to 16 bits. At the end of the measurement interval the counter is loaded into the Bit Error Rate Meter Registers [`ber_meter_low`, `ber_meter_high`; 0x4C, 0x4D].

The symbol histogrammer computes a coarse histogram of the received symbols. It operates by counting the number of ones received during meter timer interval [`meter_low`, `meter_high`; 0x18, 0x19]. That is, at the start of the measurement interval a counter is cleared. For each detector output which is +1 or -1, the counter is incremented. If the detector output is +3 or -3, the count is held at its previous value. The count is saturated to 16 bits. At the end of the measurement interval, the 8 MSBs of the counter are loaded into the Symbol Histogram Meter Register [`symbol_histogram`; 0x4E].

The noise level meter estimates the noise at the input to the slicer. It operates by accumulating the absolute value of the slicer error over meter timer interval [meter\_low, meter\_high; 0x18, 0x19]. At the end of the measurement interval, the 16 MSBs of the 32-bit accumulator are loaded into the Noise Level Histogram Meter Register [nlm\_low, nlm\_high; 0x50, 0x51].

The SNR alarm provides a rapid indication of impulse noise disturbances and loss of signal so that corrective action can be taken. The alarm is based on a second noise level meter. The meter is the same as the preceding noise level meter except it operates on a dedicated timer, the SNR alarm timer. The absolute value of the slicer error is accumulated during the timer period. At the end of the measurement interval, the 16 MSBs of the accumulator are compared against the SNR Alarm Threshold Register [snr\_alarm\_th\_low, snr\_alarm\_th\_high; 0x34, 0x35]. If the result is greater than this threshold, an interrupt is set in the irq\_source register. The threshold is set via the microcomputer interface.

## 2.3 Timing Recovery and Clock Interface

The timing recovery and clock interface block diagram consists of the timing recovery circuit and the crystal amplifier, as detailed in Figure 2-5. The main purpose of this circuitry is to recover the clock from the received data. Control fields include the `hclk_freq[1,0]` bits of the Serial Monitor Source Select Register [`serial_monitor_source`; 0x01], the PLL Modes Register [`pll_modes`; 0x22], the Timing Recovery PLL Phase Offset Register [`pll_phase_offset_low`, `pll_phase_offset_high`; 0x24, 0x25] and the PLL Frequency Register [`pll_frequency_low`, `pll_frequency_high`; 0x5E, 0x5F]. See the Register section of this datasheet for descriptions of these control fields.

Figure 2-5. Timing Recovery and Clock Interface Block Diagram

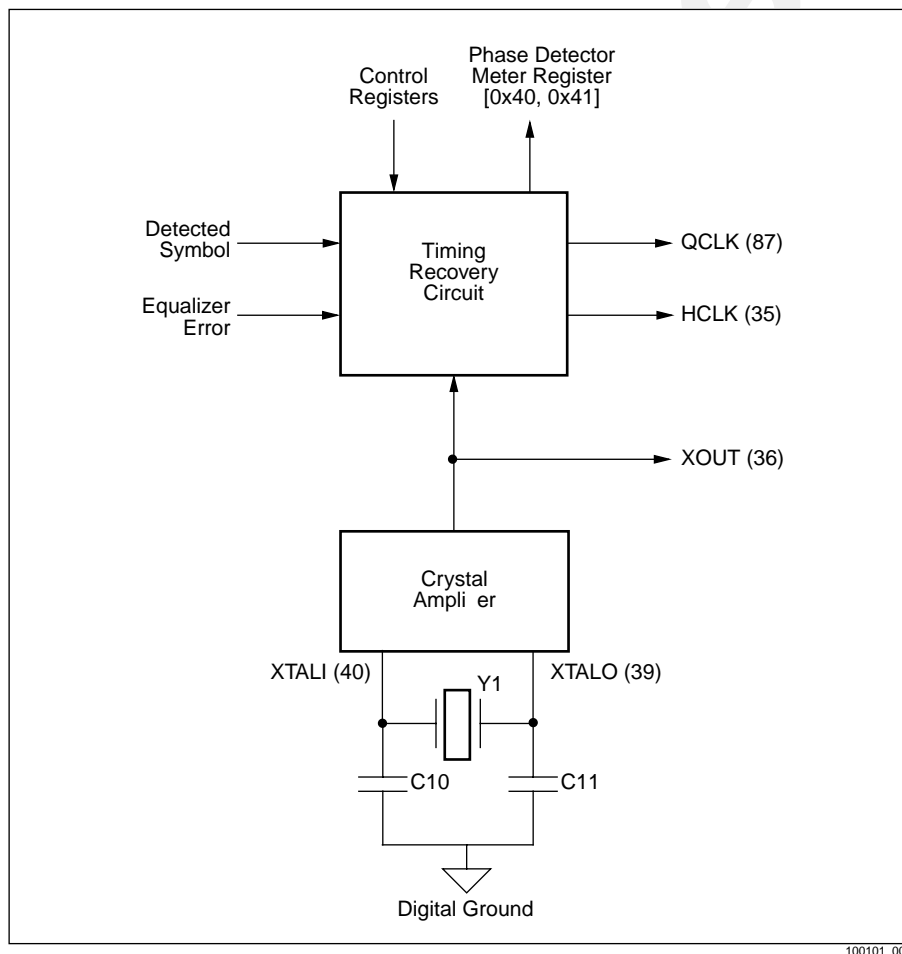

### 2.3.0.7 Timing Recovery Circuit

The timing recovery circuit uses the Bt8970's internal detected symbol and equalizer error signals to regenerate the received data symbol clock (QCLK). The HCLK output is synchronized with the edges of the symbol clock (QCLK), unlike the XOUT output which is a buffered output of the crystal amplifier. HCLK can be programmed for rates of 16, 32, or 64 times the symbol rate.

The timing recovery circuit includes a phase detector meter that measures the average value of the phase correction signal. This information can be used during startup to set the phase offset in the Receive Phase Select Register [receive\_phase\_select; 0x07]. The output of the phase detector is accumulated over the meter timer interval [meter\_low, meter\_high; 0x18, 0x19]. At the end of the measurement interval, the value is loaded into the Phase Detector Meter Register [pdm\_low, pdm\_high; 0x40, 0x41].

The user can also bypass the timing recovery circuit and directly specify the frequency via the PLL Frequency Register [pll\_frequency\_low, pll\_frequency\_high; 0x5E, 0x5F].

### 2.3.0.8 Crystal Amplifier

The crystal amplifier reduces the support circuitry needed for the Bt8970 by eliminating the need for an external Voltage-Controlled Crystal Oscillator (VCXO) or a Crystal Oscillator (XO). A crystal can be connected directly to the XTALI and XTALO pins. Table 2-6 gives the recommended component values for this circuit. The crystal amplifier can also accommodate an external clock input by connecting the external clock to the XTALI input pin.

Table 2-6. Crystal Oscillator Circuit Component Values

Component	Value
Y1	8 times the data rate

## 2.4 Channel Unit Interface

The quaternary signals of the channel unit interface have four modes which are programmable through bits 0 and 1 of the Channel Unit Interface Modes Register [cu\_interface\_modes; 0x06]. They are: serial sign-bit first, serial magnitude-bit first, parallel master, and parallel slave.

In serial mode, a Bit-Rate Clock (BCLK) is output at twice the symbol rate. The sign and magnitude bits of the receive data are output through RDAT on the rising edge of BCLK. The sign and magnitude bits of the transmit data are sampled on the falling edge of BCLK at the TDAT input. The sign bit is transferred first, followed by the magnitude bit of a given symbol in sign-bit first mode, while the opposite occurs in magnitude-bit first mode. The clock relationships for serial sign-bit first mode are illustrated in [Figure 2-6](#).

Figure 2-6. Serial Sign-Bit First Mode

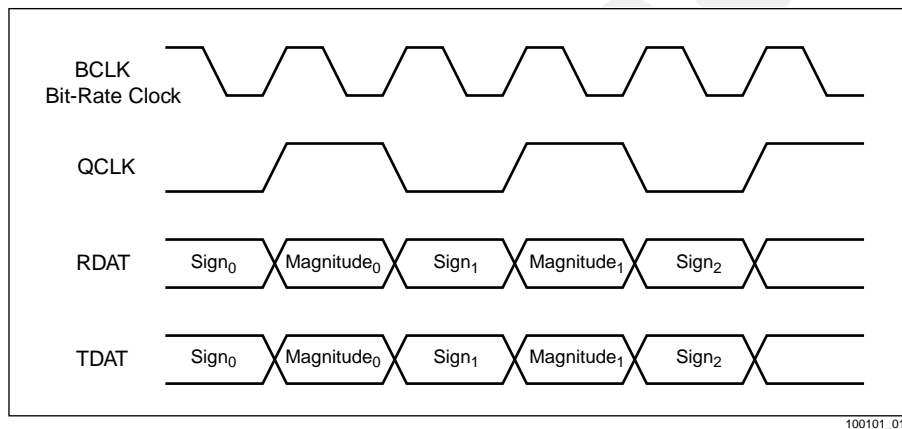

In parallel master mode, the sign and magnitude receive data is output through RQ[1] and RQ[0], respectively, on the rising edge of QCLK. The quaternary transmit data is sampled on the falling edge of QCLK. This clock and data relationship is illustrated in [Figure 2-7](#).

Figure 2-7. Parallel Master Mode

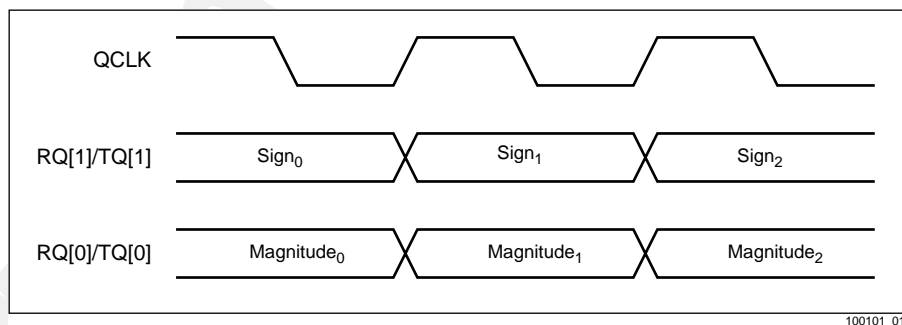

Parallel slave mode uses RBCLK and TBCLK inputs to synchronize data transfer. RBCLK and TBCLK must be frequency-locked to QCLK, though the use of two internal FIFOs allow an arbitrary phase relationship to QCLK. TQ[1] and TQ[0] are sampled on the active edge of TBCLK, as programmed through the MCI. RQ[1] and RQ[0] are output on the active edge of RBCLK, also as programmed through the MCI. The clock relationships for the case where TBCLK is programmed to be falling-edge active and RBCLK is rising-edge active are illustrated in Figure 2-8.

Figure 2-8. Parallel Slave Mode

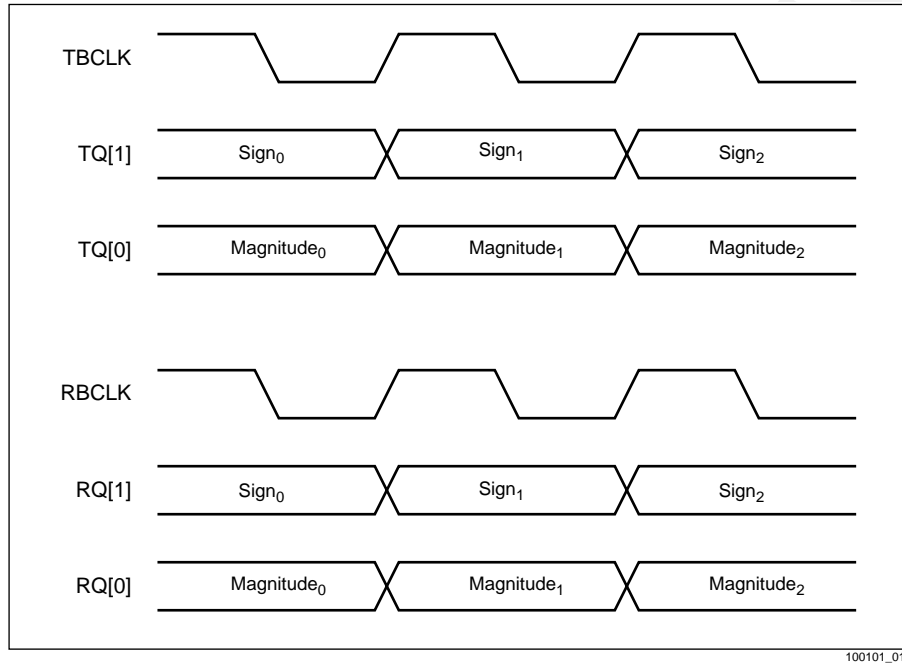

11/29/00 10:00 A.M.

## 2.5 Microcomputer Interface

The microcomputer interface provides operational mode control and status through internal registers. A microcomputer write sets the operating modes to the appropriate registers. A read to a register verifies the operating mode or provides the status. The microcomputer interface can be programmed to generate an interrupt on certain conditions.

### 2.5.1 Source Code

Rockwell provides portable C-source code under a no-cost licensing agreement. This source code provides a startup procedure, as well as diagnostic and system monitoring functions.

### 2.5.2 Microcomputer Read/Write

The microcomputer interface uses either an 8-bit-wide multiplexed address-data bus (Intel-style), or an 8-bit-wide data bus and another separate 8-bit-wide address bus (Motorola-style) for external data communications. The interface provides access to the internal control and status registers, coefficients, and microcode RAM. The interface is compatible with Intel or Motorola microcomputers, and is configured with the inputs,  $\overline{\text{MOTEL}}$  and  $\overline{\text{MUXED}}$ .  $\overline{\text{MOTEL}}$  low selects Intel-type microcomputer and control signals:  $\overline{\text{ALE}}$ ,  $\overline{\text{CS}}$ ,  $\overline{\text{RD}}$ , and  $\overline{\text{WR}}$ .  $\overline{\text{MOTEL}}$  high selects Motorola-type microcomputer and control signals:  $\overline{\text{ALE}}$ ,  $\overline{\text{CS}}$ ,  $\overline{\text{DS}}$ , and  $\overline{\text{R/W}}$ .  $\overline{\text{MUXED}}$  high configures the interface to use the multiplexed address-data bus with both the address and data on the AD[7:0] pins.  $\overline{\text{MUXED}}$  low configures the interface to use separate address and data bused with the data on the AD[7:0] pins and the address on the ADDR[7:0] pins. The  $\overline{\text{READY}}$  pin is provided to indicate when the Bt8970 is ready to transfer data and can be used by the microcomputer to insert wait states in read or write cycles.

The microcomputer interface provides access to a 256-byte internal address space. These registers provide configuration, control, status, and monitoring capabilities. Meter values are read lower-byte then upper-byte. When the lower-byte is read, the upper-byte is latched at the corresponding value. This ensures that multiple byte values correspond to the same reading. Most information can be directly read or written; however, the filter coefficients require an indirect access.

#### 2.5.2.1 RAM Access Registers

The internal RAMs of the transmit filter, LEC, NEC, DFE, equalizer, and microcode are accessed indirectly. They all share a common data register which is used for both read and write operations, Access Data Register [access\_data\_byte[3:0]; [0x7C–0x7F]. Each RAM has an individual read select and write select register. These registers specify the location to access and trigger the actual RAM read or write.

To perform a read, the address of the desired RAM location is first written to the corresponding read tap select register. Two symbol periods afterwards, the individual bytes of that location are available for reading from the Access Data Register.

To perform a write, the value to be written is first stored in the Access Data Register. The address of the affected RAM location is then written to the corresponding write tap select register. When writing the same value to multiple locations, it is not necessary to rewrite the Access Data Register.

To assure reliable access to the embedded RAMs, internal read and write operations are performed synchronous to the symbol clock. This has the effect of limiting access to these internal RAMs to one every other cycle.

When reading or writing multiple filter coefficients, it may be desirable to freeze adaptation so that all values will correspond to the same state.

### 2.5.2.2 Multiplexed Address/Data Bus

The timing for a read or write cycle is stated explicitly in the Electrical and Mechanical Specifications section. During a read operation, an external microcomputer places an address on the address-data bus which is then latched on the falling edge of ALE. Data is placed on the address-data bus after  $\overline{CS}$ ,  $\overline{RD}$ , or  $\overline{DS}$  go low. The read cycle is completed with the rising edge of  $\overline{CS}$ ,  $\overline{RD}$ , or  $\overline{DS}$ .

A write operation latches the address from the address-data bus at the falling edge of ALE. The microcomputer places data on the address-data bus after  $\overline{CS}$ ,  $\overline{WR}$ , or  $\overline{DS}$  go low. Motorola MCI will have  $R/\overline{W}$  falling edge preceding the falling edge of  $\overline{CS}$  and  $\overline{DS}$ . The rising edge of  $R/\overline{W}$  will occur after the rising edge of  $\overline{CS}$  and  $\overline{DS}$ . Data is latched on the address-data bus on the rising edge of  $\overline{WR}$  or  $\overline{DS}$ .

### 2.5.2.3 Separated Address/Data Bus

The timing for a read or write cycle using the separated address and data buses is essentially the same as over the multiplexed bus. The one exception is that the address must be driven onto the ADDR[7:0] bus rather than the AD[7:0] bus.

## 2.5.3 Interrupt Request

The twelve interrupt sources consist of: eight timers, a far-end signal high alarm, a far-end signal low alarm, a SNR alarm, and a scrambler synchronization detection. All of the interrupts are requested on a common pin,  $\overline{IRQ}$ . Each interrupt may be individually enabled or disabled through the Interrupt Mask Registers [mask\_low\_reg, mask\_high\_reg; 0x02, 0x03]. The cause of an interrupt is determined by reading the Timer Source Register [timer\_source; 0x04] and the  $\overline{IRQ}$  Source Register [irq\_source; 0x05].

The timer interrupt status is set only when the timer transitions to zero. Alarm interrupts cannot be cleared while the alarm is active. In other words, it cannot be cleared while the condition still exists.

$\overline{IRQ}$  is an open-drain output and must be tied to a pull-up resistor. This allows  $\overline{IRQ}$  to be tied together with a common interrupt request.

## 2.5.4 Reset

The reset input ( $\overline{RST}$ ) is an active-low input that places the transceiver in an inactive state by setting the mode bit (0) in the Global Modes and Status Register [global\_modes; 0x00]. An internal supply monitor circuit ensures that the transceiver will be in an inactive state upon initial application of power to the chip.

## 2.5.5 Registers

The Bt8970 has many directly addressable registers. These registers include control and monitoring functions. Write operations to undefined registers will have unpredictable effects. Read operations from undefined registers will have undefined results.

## 2.5.6 Timers

Eight timers are integrated into the Bt8970 to control the various on-chip meters and to aid the microcomputer in stepping through the events of the startup sequence.

The structure of each timer includes down counter, zero detect logic, and control circuitry, which determines when the counter is reloaded or decremented.

For each of the eight timers, there is a 2-byte timer interval register that determines the value from which the timer decrements. There are three 8-bit registers: the Timer Restart Register [timer\_restart; 0x0C], the Timer Enable Register [timer\_enable; 0x0D], and the Timer Continuous Mode Register [timer\_continuous; 0x0E]. These registers control the operation of the timers. Each bit of the 8-bit registers corresponds to a timer. Each logic-high bit in timer\_restart acts as an event that causes the corresponding timer to reload. Each logic-high bit in timer\_enable acts to enable the corresponding timer. Each logic-high bit in timer\_continuous acts to reload the counter after timing out.

Each counter is loaded with the value in its interval register. The counter decrements until it reaches zero. Upon reaching zero, an interrupt is generated if enabled by the Interrupt Mask Low Register [mask\_low\_reg, mask\_high\_reg; 0x02, 0x03]. The interrupt is edge-triggered so that only one interrupt will be caused by a single time out.

A prescaler may precede the timer. This increases the time span available at the expense of resolution. Only the startup timers have prescalers. Table 2-7 provides summary information on the timers.

Table 2-7. Timers

Timer Name	Purpose	Clock Rate	Control Bits
Startup Timer 1	Startup Events	Symbol rate ÷ 1024	sut 1
Startup Timer 2	Startup Events	Symbol rate ÷ 1024	sut 2
Startup Timer 3	Startup Events	Symbol rate ÷ 1024	sut 3
Startup Timer 4	Startup Events	Symbol rate ÷ 1024	sut 4
SNR Alarm Timer	SNR Measurement	Symbol rate	snr
Meter Timer	Measurement	Symbol rate	meter
General Purpose Timer 3	Miscellaneous	Symbol rate	t3
General Purpose Timer 4	Miscellaneous	Symbol rate	t4

Four timers are provided for use in timing startup events. These timers share a single prescaler which divides the symbol clock by 1,024 and supplies this slow clock to the four counters. The timers are: Startup Timer 1, Startup Timer 2, Startup Timer 3, and Startup Timer 4. Each one is independent, with separate interval timer values and interrupts.

Two timers control the measurement intervals for the various meters: the SNR Alarm Timer and the Meter Timer. The SNR Alarm Timer is used only by the low SNR, while the Meter Timer is used by all other meters, excluding the low SNR meter. Their respective interrupts are set when each of these two timers expire. There are no prescalers for these timers; they count at the symbol rate. Both timers are normally used in the continuous mode.

Two timers are provided for general use: General Purpose Timer 3 and General Purpose Timer 4. Both timers are identical. There are no prescalers for these timers; they count at the symbol rate. Each timer signals an interrupt when it expires.

## 2.6 Test and Diagnostic Interface (JTAG)

As the complexity of communications chips increases, the need to easily access individual chips for PCB verification is becoming vital. As a result, special circuitry has been incorporated within the transceiver which complies fully with IEEE standard 1149.1-1990, “Standard Test Access Port and Boundary Scan Architecture” set by the Joint Test Action Group (JTAG).

JTAG has four dedicated pins that comprise the Test Access Port (TAP): Test Mode Select (TMS), Test Clock (TCK), Test Data Input (TDI), and Test Data Out (TDO). Verification of the integrated circuit and its connection to other modules on the printed circuit board can be achieved through these four TAP pins.

JTAG’s approach to testability utilizes boundary scan cells placed at each digital pin, both inputs and outputs. All scan cells are interconnected into a boundary-scan register which applies or captures test data used for functional verification of the PC board interconnection. JTAG is particularly useful for board testers using functional testing methods.

With boundary-scan cells at each digital pin, the ability to apply and capture the respective logic levels is provided. Since all of the digital pins are interconnected as a long shift register, the TAP logic has access and control of all necessary pins to verify functionality. For mixed signal ICs, the chip boundary definition is expanded to include the on-chip interface between digital and analog circuitry. Internal supply monitor circuitry ensures that each pin is initialized to operate as an 2B1Q transceiver, instead of JTAG test mode during a powerup sequence.

The JTAG standard defines an optional device identification register. This register is included and contains a revision number, a part number, and a manufacturers identification code specific to Rockwell. Access to this register is through the TAP controller via the standard JTAG instruction set (see [Table 2-8](#)).

A variety of verification procedures can be performed through the TAP controller. Board connectivity can be verified at all digital pins through a set of four instructions accessible through the use of a state machine standard to all JTAG controllers. Refer to the IEEE 1149.1 specification for details concerning the Instruction Register and JTAG state machine. A Boundary Scan Description Language (BSDL) file for the Bt8970 is also available from the factory upon request.

**Table 2-8. JTAG Device Identification Register**

Version <sup>(1)</sup>	Part Number	Manufacturer ID	
0 0 0 0	0 0 1 0 0 0 1 1 0 0 0 0 1 0 1 0	0 0 0 1 1 0 1 0 1 1 0 1	
0x0	0x230A (Bt8970)	0x0D6	
4 bits	16 bits	11 bits	TDO
<sup>(1)</sup> Consult factory for current version number			

Preliminary Review

11/29/00 10:00 A.M.

## 3.0 Register Summary

Table 3-1. Register Table (1 of 5)

ADDR (hex)	Register Label	Read Write	Bit Number							
			7	6	5	4	3	2	1	0
0x00	global_modes	R/W	hw_revision[3]	hw_revision[2]	hw_revision[1]	hw_revision[0]	part_id[2]	part_id[1]	part_id[0]	mode
0x01	serial_monitor_source	R/W	hclk_freq[1]	hclk_freq[0]	smon[5]	smon[4]	smon[3]	smon[2]	smon[1]	smon[0]
0x02	mask_low_reg	R/W	t4	t3	snr	meter	sut4	sut3	sut2	sut1
0x03	mask_high_reg	R/W	—	—	—	—	sync	high_felm	low_felm	low_snr
0x04	timer_source	R/W	t4	t3	snr	meter	sut4	sut3	sut2	sut1
0x05	irq_source	R/W	—	—	—	—	sync	high_felm	low_felm	low_snr
0x06	cu_interface_modes	R/W	—	—	—	tbclk_pol	rbclk_pol	fifos_mode	interface_mode1	interface_mode[0]
0x07	receive_phase_select	R/W	—	—	—	—	rphs[3]	rphs[2]	rphs[1]	rphs[0]
0x08	linear_ec_modes	R/W	—	—	enable_dc_tap	adapt_coefficients	zero_coefficients	zero_output	adapt_gain[1]	adapt_gain[0]
0x09	nonlinear_ec_modes	R/W	negate_symbol	symbol_delay[2]	symbol_delay[1]	symbol_delay[0]	adapt_coefficients	zero_coefficients	zero_output	adapt_gain
0x0A	dfe_modes	R/W	—	—	—	—	adapt_coefficients	zero_coefficients	zero_output	adapt_gain
0x0B	transmitter_modes	R/W	—	isolated_pulse[1]	isolated_pulse[0]	transmitter_off	htur_lfsr	data_source[2]	data_source[1]	data_source[0]
0x0C	timer_restart	R/W	t4	t3	snr	meter	sut4	sut3	sut2	sut1
0x0D	timer_enable	R/W	t4	t3	snr	meter	sut4	sut3	sut2	sut1
0x0E	timer_continuous	R/W	t4	t3	snr	meter	sut4	sut3	sut2	sut1
0x0F	reserved2	R/W	D[7]	D[6]	D[5]	D[4]	D[3]	D[2]	D[1]	D[0]
0x10	sut1_low	R/W	D[7]	D[6]	D[5]	D[4]	D[3]	D[2]	D[1]	D[0]
0x11	sut1_high	R/W	D[15]	D[14]	D[13]	D[12]	D[11]	D[10]	D[9]	D[8]

Table 3-1. Register Table (2 of 5)

ADDR (hex)	Register Label	Read Write	Bit Number							
			7	6	5	4	3	2	1	0
0x12	sut2_low	R/W	D[7]	D[6]	D[5]	D[4]	D[3]	D[2]	D[1]	D[0]
0x13	sut2_high	R/W	D[15]	D[14]	D[13]	D[12]	D[11]	D[10]	D[9]	D[8]
0x14	sut3_low	R/W	D[7]	D[6]	D[5]	D[4]	D[3]	D[2]	D[1]	D[0]
0x15	sut3_high	R/W	D[15]	D[14]	D[13]	D[12]	D[11]	D[10]	D[9]	D[8]
0x16	sut4_low	R/W	D[7]	D[6]	D[5]	D[4]	D[3]	D[2]	D[1]	D[0]
0x17	sut4_high	R/W	D[15]	D[14]	D[13]	D[12]	D[11]	D[10]	D[9]	D[8]
0x18	meter_low	R/W	D[7]	D[6]	D[5]	D[4]	D[3]	D[2]	D[1]	D[0]
0x19	meter_high	R/W	D[15]	D[14]	D[13]	D[12]	D[11]	D[10]	D[9]	D[8]
0x1A	snr_timer_low	R/W	D[7]	D[6]	D[5]	D[4]	D[3]	D[2]	D[1]	D[0]
0x1B	snr_timer_high	R/W	D[15]	D[14]	D[13]	D[12]	D[11]	D[10]	D[9]	D[8]
0x1C	t3_low	R/W	D[7]	D[6]	D[5]	D[4]	D[3]	D[2]	D[1]	D[0]
0x1D	t3_high	R/W	D[15]	D[14]	D[13]	D[12]	D[11]	D[10]	D[9]	D[8]
0x1E	t4_low	R/W	D[7]	D[6]	D[5]	D[4]	D[3]	D[2]	D[1]	D[0]
0x1F	t4_high	R/W	D[15]	D[14]	D[13]	D[12]	D[11]	D[10]	D[9]	D[8]
0x20	reserved9	R/W	D[7]	D[6]	D[5]	D[4]	D[3]	D[2]	D[1]	D[0]
0x21	adc_control	R/W	—	—	loop_back[1]	loop_back[0]	—	gain[2]	gain[1]	gain[0]
0x22	pll_modes	R/W	clk_freq[1]	clk_freq[0]	—	phase_detector_ gain[1]	phase_detector_ gain[0]	freeze_pll	pll_gain[1]	pll_gain[0]
0x23	reserved10	R/W	D[7]	D[6]	D[5]	D[4]	D[3]	D[2]	D[1]	D[0]
0x24	pll_phase_offset_low	R/W	D[7]	D[6]	D[5]	D[4]	D[3]	D[2]	D[1]	D[0]
0x25	pll_phase_offset_high	R/W	D[15]	D[14]	D[13]	D[12]	D[11]	D[10]	D[9]	D[8]

11/29/00 10:00 A.M.

Table 3-1. Register Table (3 of 5)

ADDR (hex)	Register Label	Read Write	Bit Number							
			7	6	5	4	3	2	1	0
0x26	dc_offset_low	R/W	D[7]	D[6]	D[5]	D[4]	D[3]	D[2]	D[1]	D[0]
0x27	dc_offset_high	R/W	D[15]	D[14]	D[13]	D[12]	D[11]	D[10]	D[9]	D[8]
0x28	tx_calibrate	R/W	—	—	tx_calibrate[3]	tx_calibrate[2]	tx_calibrate[1]	tx_calibrate[0]	—	—
0x29	tx_gain	R/W	—	—	tx_gain[3]	tx_gain[2]	tx_gain[1]	tx_gain[0]	—	—
0x2A	noise_histogram_th_low	R/W	D[7]	D[6]	D[5]	D[4]	D[3]	D[2]	D[1]	D[0]
0x2B	noise_histogram_th_high	R/W	D[15]	D[14]	D[13]	D[12]	D[11]	D[10]	D[9]	D[8]
0x2C	ep_pause_th_low	R/W	D[7]	D[6]	D[5]	D[4]	D[3]	D[2]	D[1]	D[0]
0x2D	ep_pause_th_high	R/W	D[15]	D[14]	D[13]	D[12]	D[11]	D[10]	D[9]	D[8]
0x2E	scr_sync_th	R/W	D[7]	D[6]	D[5]	D[4]	D[3]	D[2]	D[1]	D[0]
0x30	far_end_high_alarm_th_low	R/W	D[7]	D[6]	D[5]	D[4]	D[3]	D[2]	D[1]	D[0]
0x31	far_end_high_alarm_th_high	R/W	D[15]	D[14]	D[13]	D[12]	D[11]	D[10]	D[9]	D[8]
0x32	far_end_low_alarm_th_low	R/W	D[7]	D[6]	D[5]	D[4]	D[3]	D[2]	D[1]	D[0]
0x33	far_end_low_alarm_th_high	R/W	D[15]	D[14]	D[13]	D[12]	D[11]	D[10]	D[9]	D[8]
0x34	snr_alarm_th_low	R/W	D[7]	D[6]	D[5]	D[4]	D[3]	D[2]	D[1]	D[0]
0x35	snr_alarm_th_high	R/W	D[15]	D[14]	D[13]	D[12]	D[11]	D[10]	D[9]	D[8]
0x36	cursor_level_low	R/W	D[7]	D[6]	D[5]	D[4]	D[3]	D[2]	D[1]	D[0]
0x37	cursor_level_high	R/W	D[15]	D[14]	D[13]	D[12]	D[11]	D[10]	D[9]	D[8]
0x38	dagc_target_low	R/W	D[7]	D[6]	D[5]	D[4]	D[3]	D[2]	D[1]	D[0]
0x39	dagc_target_high	R/W	D[15]	D[14]	D[13]	D[12]	D[11]	D[10]	D[9]	D[8]
0x3A	detector_modes	R/W	enable_peak_ detector	output_mux_ control[1]	output_mux_ control[0]	scr_out_to_dfe	two_level	lfsr_lock	htur_lfsr	descr_on

Table 3-1. Register Table (4 of 5)

ADDR (hex)	Register Label	Read Write	Bit Number							
			7	6	5	4	3	2	1	0
0x3B	peak_detector_delay	R/W	—	—	—	—	D[3]	D[2]	D[1]	D[0]
0x3C	dagc_modes	R/W	—	—	—	—	—	eq_error_ adaption	adapt_coefficient	adapt_gain
0x3D	ffe_modes	R/W	—	—	—	—	adapt_last_coeff	zero_coefficients	adapt_coefficient	adapt_gain
0x3E	ep_modes	R/W	—	—	—	—	zero_output	zero_coefficients	adapt_coefficients	adapt_gain
0x40	pdm_low	R/W	D[17]	D[16]	D[15]	D[14]	D[13]	D[12]	D[11]	D[10]
0x41	pdm_high	R/W	D[25]	D[24]	D[23]	D[22]	D[21]	D[20]	D[19]	D[18]
0x42	overflow_meter	R/W	D[7]	D[6]	D[5]	D[4]	D[3]	D[2]	D[1]	D[0]
0x44	dc_meter_low	R/W	D[23]	D[22]	D[21]	D[20]	D[19]	D[18]	D[17]	D[16]
0x45	dc_meter_high	R/W	D[31]	D[30]	D[29]	D[28]	D[27]	D[26]	D[25]	D[24]
0x46	slm_low	R/W	D[23]	D[22]	D[21]	D[20]	D[19]	D[18]	D[17]	D[16]
0x47	slm_high	R/W	D[31]	D[30]	D[29]	D[28]	D[27]	D[26]	D[25]	D[24]
0x48	felm_low	R/W	D[23]	D[22]	D[21]	D[20]	D[19]	D[18]	D[17]	D[16]
0x49	felm_high	R/W	D[31]	D[30]	D[29]	D[28]	D[27]	D[26]	D[25]	D[24]
0x4A	noise_histogram_low	R/W	D[7]	D[6]	D[5]	D[4]	D[3]	D[2]	D[1]	D[0]
0x4B	noise_histogram_high	R/W	D[15]	D[14]	D[13]	D[12]	D[11]	D[10]	D[9]	D[8]
0x4C	ber_meter_low	R/W	D[7]	D[6]	D[5]	D[4]	D[3]	D[2]	D[1]	D[0]
0x4D	ber_meter_high	R/W	D[15]	D[14]	D[13]	D[12]	D[11]	D[10]	D[9]	D[8]
0x4E	symbol_histogram	R/W	D[7]	D[6]	D[5]	D[4]	D[3]	D[2]	D[1]	D[0]
0x50	nlm_low	R/W	D[23]	D[22]	D[21]	D[20]	D[19]	D[18]	D[17]	D[16]
0x51	nlm_high	R/W	D[31]	D[30]	D[29]	D[28]	D[27]	D[26]	D[25]	D[24]

11/29/00 10:00 A.M.

Table 3-1. Register Table (5 of 5)

ADDR (hex)	Register Label	Read Write	Bit Number							
			7	6	5	4	3	2	1	0
0x5E	pll_frequency_low	R/W	D[22]	D[21]	D[20]	D[19]	D[18]	D[17]	D[16]	D[15]
0x5F	pll_frequency_high	R/W	D[30]	D[29]	D[28]	D[27]	D[26]	D[25]	D[24]	D[23]
0x70	linear_ec_tap_select_read	R/W	—	D[6]	D[5]	D[4]	D[3]	D[2]	D[1]	D[0]
0x71	linear_ec_tap_select_write	R/W	—	D[6]	D[5]	D[4]	D[3]	D[2]	D[1]	D[0]
0x72	nonlinear_ec_tap_select_read	R/W	—	—	D[5]	D[4]	D[3]	D[2]	D[1]	D[0]
0x73	nonlinear_ec_tap_select_write	R/W	—	—	D[5]	D[4]	D[3]	D[2]	D[1]	D[0]
0x74	dfe_tap_select_read	R/W	—	D[6]	D[5]	D[4]	D[3]	D[2]	D[1]	D[0]
0x75	dfe_tap_select_write	R/W	—	D[6]	D[5]	D[4]	D[3]	D[2]	D[1]	D[0]
0x76	sp_tap_select_read	R/W	—	—	D[5]	D[4]	D[3]	D[2]	D[1]	D[0]
0x77	sp_tap_select_write	R/W	—	—	D[5]	D[4]	D[3]	D[2]	D[1]	D[0]
0x78	eq_add_read	R/W	—	—	D[5]	D[4]	D[3]	D[2]	D[1]	D[0]
0x79	eq_add_write	R/W	—	—	D[5]	D[4]	D[3]	D[2]	D[1]	D[0]
0x7A	eq_microcode_add_read	R/W	—	—	D[5]	D[4]	D[3]	D[2]	D[1]	D[0]
0x7B	eq_microcode_add_write	R/W	—	—	D[5]	D[4]	D[3]	D[2]	D[1]	D[0]
0x7C	access_data_byte0	R/W	D[7]	D[6]	D[5]	D[4]	D[3]	D[2]	D[1]	D[0]
0x7D	access_data_byte1	R/W	D[15]	D[14]	D[13]	D[12]	D[11]	D[10]	D[9]	D[8]
0x7E	access_data_byte2	R/W	D[23]	D[22]	D[21]	D[20]	D[19]	D[18]	D[17]	D[16]
0x7F	access_data_byte3	R/W	D[31]	D[30]	D[29]	D[28]	D[27]	D[26]	D[25]	D[24]

Preliminary Review

11/29/00 10:00 A.M.

## 4.0 Register

### 0x00—Global Modes and Status Register (global\_modes)

7	6	5	4	3	2	1	0
hw_revision[3]	hw_revision[2]	hw_revision[1]	hw_revision[0]	part_id[2]	part_id[1]	part_id[0]	mode

**hw\_revision[3:0]** Chip Revision Number—Read-only unsigned binary field encoded with the chip revision number. Smaller values represent earlier versions, while larger values represent later versions. The zero value represents the original prototype release. Consult factory for current values and revision.

**part\_id[2:0]** Part ID—Read-only binary field set to binary 010 identifying the part as Bt8970.

**mode** Power Down Mode—Read/write control bit. When set, stops all filter processing and zeros the transmit output for reduced power consumption. All RAM contents are preserved. The mode bit is automatically set by  $\overline{\text{RST}}$  assertion and upon initial power application. It can be cleared only by writing a logic zero, at which time filter processing and transmitter operation can proceed.

### 0x01—Serial Monitor Source Select Register (serial\_monitor\_source)

7	6	5	4	3	2	1	0
hclk_freq[1]	hclk_freq[0]	smon[5]	smon[4]	smon[3]	smon[2]	smon[1]	smon[0]

**hclk\_freq[1,0]** HCLK Frequency Select—Read/write binary field selects the frequency of the HCLK output.

hclk_freq[1]	hclk_freq[0]	HCLK Frequency
0	0	Symbol Frequency ( $F_{\text{OCLK}}$ ) times 16 hclk_freq[1,0] is set to “00” upon assertion of the $\overline{\text{RST}}$ pin and power-on detection.
0	1	Symbol Frequency ( $F_{\text{OCLK}}$ ) times 16
1	0	Symbol Frequency ( $F_{\text{OCLK}}$ ) times 32
1	1	Symbol Frequency ( $F_{\text{OCLK}}$ ) times 64

smon[5:0] Serial Monitor Source Select—Read/write binary field selects the Serial Monitor (SMON) output source.

smon[5:0]		Source
Decimal	Binary	
0 – 47	00 0000 – 10 1111	Equalizer Register File
48	11 0000	Digital Front-End Output/LEC Input
49	11 0001	Linear Echo Replica
50	11 0010	DFE Subtractor Output/EP Input
51	11 0011	EP Subtractor Output/Slicer Input
52	11 0100	Timing Recovery Phase Detector Output/Loop Filter Input
53	11 0101	Timing Recovery Loop Filter Output/Frequency Synthesizer Input

### 0x02—Interrupt Mask Register Low (mask\_low\_reg)

Independent read/write mask bits for each of the Timer Source Register [timer\_source; 0x04] interrupt flags. A logic one represents the masked condition. A logic zero represents the unmasked condition. All mask bits behave identically with respect to their corresponding interrupt flags. Setting a mask bit prevents the corresponding interrupt flag from affecting the  $\overline{IRQ}$  output. Clearing a mask allows the interrupt flag to affect  $\overline{IRQ}$  output. Unmasking an active interrupt flag will immediately cause the  $\overline{IRQ}$  output to go active, if currently inactive. Masking an active interrupt flag will cause  $\overline{IRQ}$  to go inactive, if no other unmasked interrupt flags are set.

7	6	5	4	3	2	1	0
t4	t3	snr	meter	su4	sut3	sut2	sut1

t4 General Purpose Timer 4  
t3 General Purpose Timer 3  
snr SNR Alarm Timer  
meter Meter Timer  
sut4 Startup Timer 4  
sut3 Startup Timer 3  
sut2 Startup Timer 2  
sut1 Startup Timer 1

### 0x03—Interrupt Mask Register High (mask\_high\_reg)

Independent read/write mask bits for each of the IRQ Source Register [irq\_source; 0x05] interrupt flags. Individual mask bit behavior is identical to that specified for Interrupt Mask Register Low [mask\_low\_reg; 0x02].

7	6	5	4	3	2	1	0
-	-	-	-	sync	high_felm	low_felm	low_snr

sync	Sync Indication
high_felm	Far-End Level Meter High Alarm
low_felm	Far-End Level Meter High Alarm
low_snr	Signal-to-Noise Ratio Low Alarm

### 0x04—Timer Source Register (timer\_source)

Independent read/write (zero only) interrupt flags, one for each of eight internal timers. Each flag bit is set and stays set when its corresponding timer value transitions from one to zero. If unmasked, this event will cause the  $\overline{\text{IRQ}}$  output to be activated. Flags are cleared by writing them with a logic zero value. Once cleared, a steady-state timer value of zero will not cause a flag to be reasserted. Clearing an unmasked flag will cause the  $\overline{\text{IRQ}}$  output to return to the inactive state, if no other unmasked interrupt flags are set.

7	6	5	4	3	2	1	0
t4	t3	snr	meter	sut4	sut3	sut2	sut1

t4	General Purpose Timer 4
t3	General Purpose Timer 3
snr	SNR Alarm Timer
meter	Meter Timer
sut4	Startup Timer 4
sut3	Startup Timer 3
sut2	Startup Timer 2
sut1	Startup Timer 1

## 0x05—IRQ Source Register (irq\_source)

Independent read/write (zero only) interrupt flags, one for each of four internal sources. Each flag bit is set and stays set when its corresponding source indicates that a valid interrupt condition exists. If unmasked, this event will cause the  $\overline{\text{IRQ}}$  output to be activated. Writing a logic zero to an interrupt flag whose underlying condition no longer exists will cause the flag to be immediately cleared. Attempting to clear a flag whose underlying condition still exists will not immediately clear the flag, but will allow it to remain set until the underlying condition expires, at which time the flag will be cleared automatically. The clearing of an unmasked flag will cause the  $\overline{\text{IRQ}}$  output to return to an inactive state, if no other unmasked interrupt flags are set.

7	6	5	4	3	2	1	0
-	-	-	-	sync	high_felm	low_felm	low_snr

sync	Sync Indication—Active when the sync detector is enabled and its accumulated equivalent comparisons exceeds (greater than) the threshold value stored in the Scrambler Sync Threshold Register [scr_sync_th; 0x2E].
high_felm	Far-End Level Meter High Alarm—Active when the far-end level meter value exceeds (greater than) the threshold stored in the Far-End High Alarm Threshold Registers [far_end_high_alarm_th_low, far_end_high_alarm_th_high; 0x30–0x31].
low_felm	Far-End Level Meter Low Alarm—Active when the far-end level meter value exceeds (less than) the threshold stored in the Far-End Low Alarm Threshold Registers [far_end_low_alarm_th_low, far_end_low_alarm_th_high; 0x32–0x33].
low_snr	Signal-to-Noise Ratio Low Alarm—Active when the SNR Alarm meter value exceeds (greater than) the threshold stored in the SNR Alarm Threshold Registers [snr_alarm_th_low, snr_alarm_th_high; 0x34–0x35].

## 0x06—Channel Unit Interface Modes Register (cu\_interface\_modes)

7	6	5	4	3	2	1	0
-	-	-	tbclk_pol	rbclk_pol	fifos_mode	interface_mode[1]	interface_mode[0]

tbclk_pol	Transmit Baud Clock Polarity—Read/write control bit defines the polarity of the TBCLK input while in the parallel slave interface mode. When set, TQ[1,0] is sampled on the falling edge of TBCLK; when cleared, TQ[1,0] is sampled on the rising edge.
rbclk_pol	Receive Baud Clock Polarity—Read/write control bit defines the polarity of the RBCLK input while in the parallel slave interface mode. When set, RQ[1,0] is updated on the falling edge of RBCLK; when cleared, RQ[1,0] is updated on the rising edge.
fifos_mode	FIFO's Mode—Read/write control bit used to stagger the transmit and receive FIFO's read and write pointers while in the parallel slave interface mode. A logic one forces the pointers to a staggered position, while a logic zero allows them to operate normally. Must be first set, then cleared once after QCLK-TBCLK-RBCLK frequency lock is achieved to maximize phase-error tolerance.
interface_mode[1,0]	Interface Mode—Read/write binary field specifies one of four operating modes for the channel unit interface.

Interface mode [1:0]	Mode	Pin Functions					
		91	90	88	89	85	86
00	Parallel Master —Parallel quat transfer synchronized to QCLK out.	Not used	Not used	RQ[1]	RQ[0]	TQ[1]	TQ[0]
01	Parallel Slave—Parallel quat transfer synchronized to separate TBCLK and RBCLK inputs.	TBCLK	RBCLK	RQ[1]	RQ[0]	TQ[1]	TQ[0]
10	Serial, Magnitude First. Serial quat transfer synchronized to BCLK out; magnitude-bit first followed by sign bit.	Not used	Not used	RDAT	BCLK	TDAT	Not used
11	Serial, Sign First. Serial quat transfer synchronized to BCLK out; sign-bit first followed by magnitude bit.	Not used	Not used	RDAT	BCLK	TDAT	Not used

**0x07—Receive Phase Select Register (receive\_phase\_select)**

7	6	5	4	3	2	1	0
-	-	-	-	rphs[3]	rphs[2]	rphs[1]	rphs[0]

**rphs[3:0]** Receive Phase Select—Read/write binary field that defines the relative phase relationship between QCLK and the sampling point of the ADC. The rising edges of QCLK corresponds to the ADC sampling point when rphs = 0000. Each binary increment of rphs represents a one-sixteenth QCLK period delay in the sampling point relative to QCLK.

**0x08—Linear Echo Canceller Modes Register (linear\_ec\_modes)**

7	6	5	4	3	2	1	0
-	-	enable_dc_tap	adapt_coefficients	zero_coefficients	zero_output	adapt_gain[1]	adapt_gain[0]

**enable\_dc\_tap** Enable DC Tap—Read/write control bit which, when set, forces a constant +1 value into the last data tap of the Linear Echo Canceller (LEC). This condition enables cancellation of any residual DC offset present at the input to the LEC. When cleared, the last data tap operates normally, as the oldest transmit data sample.

**adapt\_coefficients** Adapt Coefficients—Read/write control bit which enables coefficient adaptation when set; disables/freezes adaptation when cleared. Coefficient values are preserved when adaptation is disabled.

**zero\_coefficients** Zero Coefficients—Read/write control bit that continuously zeros all coefficients when set; allows normal coefficient updates, if enabled, when cleared. This behavior differs slightly from the similar function (zero\_coefficients) of the FFE and EP filters.

**zero\_output** Zero Output—Read/write control bit which, when set, zeros the echo replica before subtraction from the input signal. Achieves the affect of disabling or bypassing the echo cancellation function. Does not disable coefficient adaptation. When cleared, normal echo canceller operation is performed.

**adapt\_gain[1,0]** Adaptation Gain—Read/write binary field which specifies the adaptation gain.

adapt_gain[1,0]	Normalized Gain
00	1
01	4
10	64
11	512

### 0x09—Nonlinear Echo Canceller Modes Register (nonlinear\_ec\_modes)

7	6	5	4	3	2	1	0
negate_symbol	symbol_delay[2]	symbol_delay[1]	symbol_delay[0]	adapt_coefficients	zero_coefficients	zero_output	adapt_gain

- negate\_symbol**      Negate Symbol—Read/write control bit which, when set, inverts (2’s complement) the receive signal path at the output of the nonlinear echo canceller. When cleared, the signal path is unaffected. This function is independent of all other NEC mode settings.
- symbol\_delay[2:0]**    Symbol Delay—Read/write binary field which specifies the number of symbol delays inserted in the transmit symbol input path.
- adapt\_coefficients**    Adapt Coefficients—Same function as LEC Modes Register [linear\_ec\_modes; 0x08].
- zero\_coefficients**    Zero Coefficients—Same function as LEC Modes Register.
- zero\_output**          Zero Output—Same function as LEC Modes Register.
- adapt\_gain**          Adaptation Gain—Read/write control bit which specifies the adaptation gain. When set, the adaptation gain is 8 times higher than when cleared.

### 0x0A—Decision Feedback Equalizer Modes Register (dfe\_modes)

7	6	5	4	3	2	1	0
-	-	-	-	adapt_coefficients	zero_coefficients	zero_output	adapt_gain

- adapt\_coefficients**    Adapt Coefficients—Read/write control bit which enables coefficient adaptation when set; disables/freezes adaptation when cleared. Coefficient values are preserved when adaptation is disabled.
- zero\_coefficients**    Zero Coefficients—Read/write control bit which continuously zeros all coefficients when set; allows normal coefficient updates, if enabled, when cleared.
- zero\_output**          Zero Output—Read/write control bit which, when set, zeros the equalizer correction signal before subtraction from the input signal. Achieves the affect of disabling or bypassing the equalization function. Does not disable coefficient adaptation. When cleared, normal equalizer operation is performed.
- adapt\_gain**          Adaptation Gain—Read/write control bit which specifies the adaptation gain. When set, the adaptation gain is 8 times higher than when cleared.

11/29/00 10:00 A.M.

## 0x0B—Transmitter Modes Register (transmitter\_modes)

7	6	5	4	3	2	1	0
–	isolated_pulse[1]	isolated_pulse[0]	transmitter_off	htur_ifsr	data_source[2]	data_source[1]	data_source[0]

**isolated\_pulse[1,0]** Isolated Pulse Level Select—Read/write binary field that selects one of four output pulse levels while in the isolated pulse transmitter mode.

isolated_pulse[1,0]	Output Pulse Level
00	–3
01	–1
10	+3
11	+1

**transmitter\_off** Transmitter Off—Read/write control bit that zeros the output of the transmitter when set; allows normal transmitter operation (as defined by data\_source[2:0]) when cleared.

**htur\_ifsr** Remote Unit (HTU-R/NTU) Polynomial Select—Read/write control bit selects one of two feedback polynomials for the transmit scrambler. When set, this bit selects the remote unit transmit polynomial ( $x^{-23} + x^{-18} + 1$ ); when cleared, it selects the local unit (HTU-C/LTU) polynomial ( $x^{-23} + x^{-5} + 1$ ).

**data\_source[2:0]** Data Source—Read/write binary field that selects the data source and mode of the transmitter output. The transmitter must be enabled (transmitter\_off = 0) for these modes to be active.

data_source [2:0]	Transmitter Mode
000	Isolated pulse. Level selected by isolated_pulse[1:0]. The meter timer must be enabled and in the continuous mode. The pulse repetition interval is determined by the meter timer countdown interval.
001	Four-level scrambled detector loopback. Sign and magnitude bits from the receiver detector are scrambled and looped back to the transmitter. Feedback polynomial determined by the htur_ifsr control bit.
010	Four-level unscrambled data. Transmits the four-level (2B1Q) sign and magnitude bits from the channel unit transmit interface without scrambling.
011	Four-level scrambled ones. Transmits a scrambled, constant high-logic level as a four-level (2B1Q) signal. Feedback polynomial determined by the htur_ifsr control bit.
100	Reserved.
101	Four-level scrambled data. Scrambles and transmits the four-level (2B1Q) sign and magnitude bits from the channel unit transmit interface. Feedback polynomial determined by the htur_ifsr control bit.
110	Two-level unscrambled data. Constantly forces the magnitude bit from the channel unit transmit interface to a logic zero and transmits the resulting two-level signal (as determined by the sign bit) without scrambling. Valid output levels limited to +3, –3.
111	Two-level scrambled ones. Transmits a scrambled, constant high-logic level as a two-level signal. Feedback polynomial determined by the htur_ifsr control bit. Scrambler is run at the symbol rate (half-bit rate) to produce the sign bit of the transmitted signal while the magnitude bit is sourced with a constant logic zero. Valid output levels limited to +3, –3.

**0x0C—Timer Restart Register (timer\_restart)**

Independent read/write restart bits, one for each of the eight internal timers. Setting an individual bit causes the associated timer to be reloaded with the contents of its interval register. For the four symbol-rate timers (meter, snr, t3, t4), reloading will occur within one symbol period. For the four start-up timers (sut1–4), reloading will occur within 1,024 symbol periods. Once reloaded, the restart bit is automatically cleared. If a restart bit is set and then cleared (by writing a logic zero) before the reload actually takes place, no timer reload will occur. Once reloaded, if enabled in the Timer Enable Register [timer\_enable; 0x0D], the timer will begin counting down toward zero; otherwise, it will hold at the interval register value.

7	6	5	4	3	2	1	0
t4	t3	snr	meter	sut4	sut3	sut2	sut1

t4            General Purpose Timer 4

t3            General Purpose Timer 3

snr           SNR Alarm Timer

meter        Meter Timer

sut4          Startup Timer 4

sut3          Startup Timer 3

sut2          Startup Timer 2

sut1          Startup Timer 1

### 0x0D—Timer Enable Register (timer\_enable)

Independent read/write enable bits, one for each of the eight internal timers. When any individual bit is set, the corresponding timer is enabled for counting down from its current value toward zero. For the four symbol-rate timers (meter, snr, t3, t4), counting will begin within one symbol period. For the four start-up timers (sut1-4), counting will begin within 1,024 symbol periods. When an enable bit is cleared, the timer is disabled from counting while it holds its current value. If an enable bit is set and then cleared before a count actually takes place, no timer countdown will occur.

7	6	5	4	3	2	1	0
t4	t3	snr	meter	sut4	sut3	sut2	sut1

t4 General Purpose Timer 4

t3 General Purpose Timer 3

snr SNR Alarm Timer

meter Meter Timer

sut4 Startup Timer 4

sut3 Startup Timer 3

sut2 Startup Timer 2

sut1 Startup Timer 1

### 0x0E—Timer Continuous Mode Register (timer\_continuous)

Independent read/write mode bits, one for each of the eight internal timers. When any individual bit is set, the corresponding timer is placed in the continuous count mode. While in this mode, after reaching the zero count, an enabled timer will reload the contents of its interval register and continue counting. When a mode bit is cleared, the timer is taken out of the continuous mode. While in this configuration, after reaching the zero count, an enabled timer will simply stop counting and remain at zero.

7	6	5	4	3	2	1	0
t4	t3	snr	meter	sut4	sut3	sut2	sut1

### 0x0F—Test Register (reserved2)

A 1-byte read/write register used for device testing by Rockwell. This register is automatically initialized to 0x00 upon  $\overline{\text{RST}}$  assertion and initial power application. This register must be initialized according to the device driver provided by Rockwell.

### 0x10, 0x11—Startup Timer 1 Interval Register (sut1\_low, sut1\_high)

A 2-byte read/write register stores the countdown interval for Startup Timer 1 in unsigned binary format. Each increment represents 1,024 symbol periods. The contents of this register are automatically loaded into its associated timer after the timer's timer\_restart bit is set, or after it counts down to zero while in the continuous mode.

**0x12, 0x13—Startup Timer 2 Interval Register (sut2\_low, sut2\_high)**

A 2-byte read/write register stores the countdown interval for Startup Timer 2 in unsigned binary format. Each increment represents 1,024 symbol periods. The contents of this register are automatically loaded into its associated timer after the timer's timer\_restart bit is set, or after it counts down to zero while in the continuous mode.

**0x14, 0x15—Startup Timer 3 Interval Register (sut3\_low, sut3\_high)**

A 2-byte read/write register stores the countdown interval for Startup Timer 3 in unsigned binary format. Each increment represents 1,024 symbol periods. The contents of this register are automatically loaded into its associated timer after the timer's timer\_restart bit is set, or after it counts down to zero while in the continuous mode.

**0x16, 0x17—Startup Timer 4 Interval Register (sut4\_low, sut4\_high)**

A 2-byte read/write register stores the countdown interval for Startup Timer 4 in unsigned binary format. Each increment represents 1,024 symbol periods. The contents of this register are automatically loaded into its associated timer after the timer's timer\_restart bit is set, or after it counts down to zero while in the continuous mode.

**0x18, 0x19—Meter Timer Interval Register (meter\_low, meter\_high)**

A 2-byte read/write register stores the countdown interval for the Meter Timer in unsigned binary format. Each increment represents one symbol period. The contents of this register are automatically loaded into its associated timer after the timer's timer\_restart bit is set, or after it counts down to zero while in the continuous mode.

**0x1A, 0x1B—SNR Alarm Timer Interval Register (snr\_timer\_low, snr\_timer\_high)**

A 2-byte read/write register stores the countdown interval for the SNR Alarm Timer in unsigned binary format. Each increment represents one symbol period. The contents of this register are automatically loaded into its associated timer after the timer's timer\_restart bit is set, or after it counts down to zero while in the continuous mode.

**0x1C, 0x1D—General Purpose Timer 3 Interval Register (t3\_low, t3\_high)**

A 2-byte read/write register stores the countdown interval for General Purpose Timer 3 in unsigned binary format. Each increment represents one symbol period. The contents of this register are automatically loaded into its associated timer after the timer's timer\_restart bit is set, or after it counts down to zero while in the continuous mode.

**0x1E, 0x1F—General Purpose Timer 4 Interval Register (t4\_low, t4\_high)**

A 2-byte read/write register stores the countdown interval for General Purpose Timer 4 in unsigned binary format. Each increment represents one symbol period. The contents of this register are automatically loaded into its associated timer after the timer's timer\_restart bit is set, or after it counts down to zero while in the continuous mode.

**0x20—Test Register (reserved)**

A 1-byte read/write register used for device testing by Rockwell. This register is automatically initialized to 0x00 upon  $\overline{\text{RST}}$  assertion and initial power application. This register must be initialized according to the device driver provided by Rockwell.

**0x21—ADC Control Register (adc\_control)**

7	6	5	4	3	2	1	0
-	-	loop_back[1]	loop_back[0]	-	gain[2]	gain[1]	gain[0]

**loop\_back[1,0]** Loopback Control—Read/write binary field specifies if loopback is enabled, and the type of loopback that is enabled. During transmitting loopback, the differential receiver inputs (RXP, RXN) are disabled. The loopback path is intended to go from the transmitter outputs (TXP, TXN) through the external hybrid circuit and back into the differential receiver balance inputs (RXBP, RXBN). During silent loopback, the transmitter is turned off. The output of the pulse-shaping filter in the transmit section is internally connected to the input of the ADC in the receive section.

loop_back[1,0]	Function
00	Normal Operation (Loopback Disabled)
01	Hybrid Inputs Disabled (RXBP, RXBN)
10	Transmitting Loopback
11	Silent Loopback

**gain[2:0]** Gain Control—Read/write binary field specifies the gain of the VGA.

gain[2:0]	VGA Gain
000	0dB
001	3 dB
010	6 dB
011	9 dB
100	12 dB
101	15 dB
110	15 dB
111	15 dB

## 0x22—PLL Modes Register (pll\_modes)

7	6	5	4	3	2	1	0
clk_freq[1]	clk_freq[0]	negate_symbol	phase_detector_gain[1]	phase_detector_gain[0]	freeze_pll	pll_gain[1]	pll_gain[0]

**clk\_freq[1,0]** Clock Frequency Select—Read/write binary field specifies one of four data rate ranges for Bt8970 operation. The “00” state is automatically selected by  $\overline{RST}$  assertion and upon initial power application. The crystal or external clock frequency must be equal to 8 times the data rate.

clk_freq[1,0]	Data Rate Range
00	968 to 1368 kbps
01	656 to 968 kbps
10	160 to 656 kbps
11	Above 1368 kbps

**phase\_detector\_gain[1,0]**

Phase Detector Gain—Read/write binary field specifies one of four gain settings for the timing-recovery phase detector function.

phase_detector_gain[1,0]	Normalized Gain
00	1
01	2
10	4
11	Reserved

**freeze\_pll**

Freeze PLL—Read/write control bit. When set, this bit zeros the proportional term of the loop compensation filter and disables accumulator updates causing the PLL to hold its current frequency. When cleared, proportional term effects and accumulator updates are enabled allowing the PLL to track the phase of the incoming data.

**pll\_gain[1,0]**

PLL Gain—Read/write binary field specifies the gain (proportional and integral coefficients) of the loop compensation filter.

pll_gain[1:0]	Normalized Proportional Coefficients	Normalized Integral Coefficients
00	1	1
01	4	32
10	16	256
11	64	4096

**0x23—Test Register (reserved10)**

A 3-byte read/write register used for device testing by Rockwell. This register is automatically initialized to 0x000000 upon  $\overline{\text{RST}}$  assertion and initial power application. This register must be initialized according to the device driver provided by Rockwell.

**0x24, 0x25—Timing Recovery PLL Phase Offset Register (pll\_phase\_offset\_low, pll\_phase\_offset\_high)**

A 2-byte read/write register interpreted as a 16-bit, 2's-complement number. The value of this register is subtracted from the output of the timing-recovery phase detector after the phase-detector meter, but before the loop compensation filter.

**0x26, 0x27—Receiver DC Offset Register (dc\_offset\_low, dc\_offset\_high)**

A 2-byte read/write register interpreted as a 16-bit, 2's-complement number. The value of this register is subtracted from the receiver signal path at the output of the digital front end's format conversion block, ahead of the DC level and signal level meters.

**0x28—Transmitter Calibration Register (tx\_calibrate)**

7	6	5	4	3	2	1	0
-	-	tx_calibrate[3]	tx_calibrate[2]	tx_calibrate[1]	tx_calibrate[0]	-	-

**tx\_calibrate[3:0]** Transmit Calibrate—4-bit, 2's-complement, read-only field containing the nominal setting for the transmitter gain. The value of the Transmit Calibration Register is set during manufacturing testing by Rockwell and corresponds to the value required to operate the Bt8970 at a nominal 13.5 dBm transmit power, assuming the recommended transformer coupling/hybrid circuit is used. Users may override this calibration by writing their own value into the Transmitter Gain Register [tx\_gain; 0x29].

**0x29—Transmitter Gain Register (tx\_gain)**

7	6	5	4	3	2	1	0
–	–	tx_gain[3]	tx_gain[2]	tx_gain[1]	tx_gain[0]	–	–

**tx\_gain[3:0]** Transmit Gain—A 4-bit, 2's-complement, read/write field controlling the transmitter gain. Upon initialization, the value in the Transmitter Calibration Register [tx\_calibrate; 0x28] may be written into this register by software to set the transmitter gain to the nominal value, or the user may set it to another desired value.

tx_gain[3:0]	Relative Transmitter Gain (dB)
1000	–1.60
1001	–1.36
1010	–1.13
1011	–0.91
1100	–0.69
1101	–0.48
1110	–0.27
1111	–0.07
0000	0.13
0001	0.32
0010	0.51
0011	0.70
0100	0.88
0101	1.05
0110	1.23
0111	1.40

**0x2A, 0x2B—Noise-Level Histogram Threshold Register (noise\_histogram\_th\_low, noise\_histogram\_th\_high)**

Two-byte read/write register interpreted as a 16-bit, 2's-complement number. The range of meaningful values is limited to positive integers between 0x0000 and 0x7FFF. The value of this register is compared to the absolute value of the slicer error signal produced by the detector. A count of error samples that exceeds this threshold (greater than) is accumulated in the noise-level histogram meter.

### 0x2C, 0x2D—Error Predictor Pause Threshold Register (ep\_pause\_th\_low, ep\_pause\_th\_high)

Two-byte read/write register interpreted as a 16-bit, 2's-complement number. The range of meaningful values is limited to positive integers between 0x0000 and 0x7FFF. The value of this register is compared to the absolute value of the slicer error signal produced by the detector. The result of this comparison (slicer error greater than this threshold) is used to initiate a pause condition by zeroing the output of the error predictor correction signal before subtraction from the receive signal path. Error predictor coefficient updates are not affected. The pause condition lasts for a fixed 5-symbol period from the time the threshold was last exceeded.

### 0x2E—Scrambler Synchronization Threshold Register (scr\_sync\_th)

A 7-bit read/write register representing an unsigned binary number. The contents of this register are used to test for scrambler synchronization during the automatic-scrambler synchronization mode of the symbol detector. The test passes when the count of equivalent scrambler and detector output bits exceeds (greater than) the value of this register. When the auto-scrambler sync mode is not enabled, the contents of this register are not used.

7	6	5	4	3	2	1	0
-	D[6]	D[5]	D[4]	D[3]	D[2]	D[1]	D[0]

### 0x30, 0x31—Far-End High Alarm Threshold Register (far\_end\_high\_alarm\_th\_low, far\_end\_high\_alarm\_th\_high)

A 2-byte read/write register interpreted as a 16-bit, 2's-complement number. The range of meaningful values is limited to positive integers between 0x0000 and 0x7FFF. The value of this register is compared to the value of the far-end level meter. If the meter reading exceeds (greater than) this threshold, the high\_felm interrupt flag is set in the IRQ Source Register [irq\_source; 0x05].

### 0x32, 0x33—Far-End Low Alarm Threshold Register (far\_end\_low\_alarm\_th\_low, far\_end\_low\_alarm\_th\_high)

A 2-byte read/write register interpreted as a 16-bit, 2's-complement number. The range of meaningful values is limited to positive integers between 0x0000 and 0x7FFF. The value of this register is compared to the value of the far-end level meter. If the meter reading exceeds (less than) this threshold, the low\_felm interrupt flag is set in the IRQ Source Register [irq\_source; 0x05].

### 0x34, 0x35—SNR Alarm Threshold Register (snr\_alarm\_th\_low, snr\_alarm\_th\_high)

A 2-byte read/write register interpreted as a 16-bit, 2's-complement number. The range of meaningful values is limited to positive integers between 0x0000 and 0x7FFF. The value of this register is compared to the value of the SNR alarm meter. If the meter reading exceeds (greater than) this threshold, the low\_snr interrupt flag is set in the IRQ Source Register [irq\_source; 0x05].

### 0x36, 0x37—Cursor Level Register (cursor\_level\_low, cursor\_level\_high)

A 2-byte read/write register interpreted as a 16-bit, 2's-complement number. The range of meaningful values is limited to positive integers between 0x0000 and 0x2AAA (one-third of the maximum positive value). The value of this register represents the expected level of a noise-free +1 receive symbol at the output of the DFE. It is multiplied by 2 to produce the positive and negative slicing levels, in addition to zero, used by the symbol detector in four-level slicing mode. This value is also used to scale the detector output when computing the equalizer error and slicer error signals. The detected symbol (−3, −1, +1, +3) is multiplied by the value of this register to produce the scaled output.

### 0x38, 0x39—DAGC Target Register (dagc\_target\_low, dagc\_target\_high)

A 2-byte read/write register interpreted as a 16-bit, 2's-complement number. The range of meaningful values is limited to positive integers between 0x0000 and 0x7FFF. The value of this register is subtracted from the absolute value of the receive signal at the output of the Digital Automatic Gain Control (DAGC) function. The difference is used as the error input to the DAGC while in the self-adaptation mode. In the DAGC's equalizer-error adaptation mode, the contents of this register are not used.

### 0x3A—Symbol Detector Modes Register (detector\_modes)

7	6	5	4	3	2	1	0
enable_peak_detector	output_mux_control[1]	output_mux_control[0]	scr_out_to_dfe	two_level	lfsr_lock	htur_lfsr	descr_on

enable\_peak\_detector

Enable Peak Detector—Read/write control bit that enables the peak detection function when set; disables the function when cleared. When enabled, the peak detector output overrides the slicer output if the peak detection criteria are met. If the criteria are not met, or if the function is disabled, the slicer output is used and peak detector output is ignored.

output\_mux\_control[1,0]

Output Multiplexer Control—Read/write binary field that selects the source of the detector output connected to the channel unit receive interface.

output_mux_control[1,0]	Detector Output to CU Receive Interface
00	Same as scr_out_to_dfe selection
01	Transmitter loopback output from CU transmit interface
10	Scrambler/descrambler output
11	Reserved

scr\_out\_to\_dfe

Scrambler Output to DFE—Read/write control bit that selects the source of the detector output connected to the DFE and timing recovery module inputs, and the transmitter's detector loopback input. When set, this bit selects the scrambler/descrambler function; when cleared, it selects the slicer/peak detector output.

<b>two_level</b>	Two-Level Mode—Read/write control bit that selects two-level mode when set, four-level mode when cleared. Affects the slicer and the scrambler/descrambler function. In two-level mode, the slicer uses a single threshold set at zero to recover sign bits only; all magnitude information is lost. Scrambler/descrambler updates are slowed to the symbol rate (half the normal bit rate) to process only sign information as well; all magnitude output bits are sourced with a constant logic zero value producing two-level symbols constrained to +3 and –3 values. In four-level mode, the slicer uses two thresholds derived from the Cursor Level Register [cursor_level_low, cursor_level_high; 0x36–0x37], as well as the zero threshold, to recover both sign and magnitude information. The scrambler/descrambler is updated at the full bit rate to process both sign and magnitude bits as well.
<b>lfsr_lock</b>	LFSR Lock—Read/write control bit that enables the auto-scrambler synchronization mode (lfsr_lock) in the detector when set; disables this mode when cleared. Affects the behavior of the scrambler/descrambler function, overriding the descr_on setting. When enabled, the scrambler/descrambler is forced into the descrambler mode for 23 cycles. It is then switched to the scrambled-ones mode for 128 cycles. While in this mode, the outputs of the scrambler and the slicer/peak detector are compared against one another. The number of equivalent bits (equal comparisons) is accumulated and compared to the value of the Scrambler Synchronization Threshold Register [scr_sync_th; 0x2E]. At any time during the 128 cycles, if the count exceeds the threshold (greater than), the sync interrupt flag is set in the IRQ source register [irq_source; 0x05] and the process terminates with the scrambler/descrambler left in the scrambled-ones mode. (The sync interrupt flag cannot be cleared while lfsr_lock remains high.) After 128 cycles, if the threshold is not exceeded, the accumulator is cleared, the scrambler/descrambler re-enters the descrambler mode for another 23 cycles, and the process repeats until either sync is achieved or this mode is disabled. Once disabled, the sync interrupt flag can be cleared (if active) and the scrambler/descrambler returns to the mode specified by descr_on.
<b>htur_lfsr</b>	Remote Unit (HTU-R/NTU) Polynomial Select—Read/write control bit that selects one of two feedback polynomials for the scrambler/descrambler. When set, this bit selects the remote unit (HTU-R/NTU) receive polynomial ( $x^{-23} + x^{-5} + 1$ ); when cleared, is selects the local unit (HTU-C/LTU) polynomial ( $x^{-23} + x^{-18} + 1$ ).
<b>descr_on</b>	Descrambler/Scrambler Select—Read/write control bit that configures the scrambler/descrambler function as a descrambler when set, and as a scrambler when cleared. As a scrambler, this bit can only generate a scrambled-all-ones sequence (constant high logic-level input); all incoming data is ignored. In the auto-scrambler synchronization mode (lfsr_lock = 1), this selection is overwritten though the value of the control bit is unaffected.

### 0x3B—Peak Detector Delay Register (peak\_detector\_delay)

A 4-bit read/write register interpreted as an unsigned binary number. Specifies a number of additional symbol delays inserted in the peak detector input path of the symbol detector. Must be set to a value that equalizes the total path delay in each of the peak detector and slicer input paths according to the following formula: peak detector delay register value = DAGC delays + FFE delays – fixed peak detector input delays. The DAGC and FFE delays are not fixed, but result from the microprogrammed implementation of these functions. If used unmodified, they equal 0 and 7, respectively. The fixed peak detector input delay is equal to 3.

7	6	5	4	3	2	1	0
–	–	–	–	D[3]	D[2]	D[1]	D[0]

**0x3C—Digital AGC Modes Register (dagc\_modes)**

7	6	5	4	3	2	1	0
-	-	-	-	-	eq_error_adaptation	adapt_coefficient	adapt_gain

eq\_error\_adaptation

Equalizer Error Adaptation—Read/write control bit that selects between the equalizer-error adaptation mode when set, and the self-adaptation mode when cleared. Equalizer error adaptation uses the equalizer error signal produced by the slicer as the DAGC error input signal. In self adaptation, the value of the DAGC Target Register [dagc\_target\_low, dagc\_target\_high; 0x38–0x39] is subtracted from the absolute value of the receive signal at the output of the DAGC, and this difference is used as the error input signal.

adapt\_coefficient

Adapt Coefficients—Read/write control bit that enables coefficient adaptation when set; disables/freezes adaptation when cleared. Coefficient values are preserved when adaptation is disabled.

adapt\_gain

Adaptation Gain—Read/write control bit that specifies the adaptation gain. When set, the adaptation gain is eight times higher than when cleared.

**0x3D—Feed Forward Equalizer Modes Register (ffe\_modes)**

7	6	5	4	3	2	1	0
-	-	-	-	adapt_last_coeff	zero_coefficients	adapt_coefficients	adapt_gain

adapt\_last\_coeff

Adapt Last Coefficient—Read/write control bit enables adaptation of the last (oldest) coefficient only when set; allows all coefficient adaptation when cleared. Overall coefficient adaptation must be enabled (adapt\_coefficients = 1) for this behavior to occur. If coefficient adaptation is disabled (adapt\_coefficients = 0), the value of this control bit is not used.

zero\_coefficients

Zero Coefficients—Read/write control bit which, with coefficient adaptation enabled (adapt\_coefficients = 1), continuously zeros all coefficients when set; allows normal coefficient updates when cleared. If coefficient adaptation is disabled (adapt\_coefficients = 0), this control bit has no affect. This behavior differs slightly from the similar function (zero\_coefficients) of the LEC, NEC, and DFE filters.

adapt\_coefficients

Adapt Coefficients—Read/write control bit enables coefficient adaptation when set; disables/freezes adaptation when cleared. Coefficient values are preserved when adaptation is disabled. This overall coefficient adaptation must be enabled for adapt\_last\_coeff to have an affect.

adapt\_gain

Adaptation Gain—Read/write control bit specifies the adaptation gain. When set, the adaptation gain is four times higher than when cleared.

**0x3E—Error Predictor Modes Register (ep\_modes)**

7	6	5	4	3	2	1	0
-	-	-	-	zero_output	zero_coefficients	adapt_coefficients	adapt_gain

**zero\_output** Zero Output—Read/write control bit which, when set, zeros the error predictor correction signal before subtraction from the input signal. Achieves the affect of disabling, or bypassing, the error predictor function. Does not disable coefficient adaptation. When cleared, normal error predictor operation is performed.

**zero\_coefficients** Zero Coefficients—Read/write control bit which, with coefficient adaptation enabled (adapt\_coefficients = 1), continuously zeros all coefficients when set; allows normal coefficient updates when cleared. If coefficient adaptation is disabled (adapt\_coefficients = 0), this control bit has no affect. This behavior differs slightly from the similar function (zero\_coefficients) of the LEC, NEC, and DFE filters.

**adapt\_coefficients** Adapt Coefficients—Read/write control bit enables coefficient adaptation when set; disables/freezes adaptation when cleared. Coefficient values are preserved when adaptation is disabled.

**adapt\_gain** Adaptation Gain—Read/write control bit specifies the adaptation gain. When set, the adaptation gain is four times higher than when cleared.

**0x40, 0x41—Phase Detector Meter Register (pdm\_low, pdm\_high)**

A 2-byte read-only register containing the 16 MSBs of the 26-bit, 2's-complement phase detector meter accumulator. This meter sums the output of the timing recovery module's phase detector—prior to being offset by the Phase Offset Register [pll\_phase\_offset\_low, pll\_phase\_offset\_high; 0x24, 0x25]—over each Meter Timer countdown interval. Automatically loaded at the end of each interval, the meter register must be read low byte first, followed by high byte, unseparated by any other meter access (addresses 0x40 to 0x5F).

7	6	5	4	3	2	1	0
D[17]	D[16]	D[15]	D[14]	D[13]	D[12]	D[11]	D[10]
D[25]	D[24]	D[23]	D[22]	D[21]	D[20]	D[19]	D[18]

**0x42—Overflow Meter Register (overflow\_meter)**

A single-byte read-only register containing all 8 bits of the unsigned overflow meter accumulator. This meter counts the number of ADC overflow conditions which occur during each Meter Timer countdown interval, limited to a maximum count of 255 (0xFF). The meter register is automatically loaded at the end of each countdown interval.

7	6	5	4	3	2	1	0
D[7]	D[6]	D[5]	D[4]	D[3]	D[2]	D[1]	D[0]

**0x44, 0x45—DC Level Meter Register (dc\_meter\_low, dc\_meter\_high)**

A 2-byte read-only register containing the 16 MSBs of the 32-bit, 2's-complement DC-level meter accumulator. This meter sums the value of the receive signal input path—after format conversion and DC offset correction but before echo cancellation—over each Meter Timer countdown interval. Automatically loaded at the end of each interval, the meter register must be read low byte first, followed by high byte, unseparated by any other meter access (addresses 0x40 to 0x5F).

7	6	5	4	3	2	1	0
D[23]	D[22]	D[21]	D[20]	D[19]	D[18]	D[17]	D[16]
D[31]	D[30]	D[29]	D[28]	D[27]	D[26]	D[25]	D[24]

**0x46, 0x47—Signal Level Meter Register (slm\_low, slm\_high)**

A 2-byte read-only register containing 16 MSBs of the 32-bit unsigned signal-level meter accumulator. This meter sums the absolute value of the receive signal input path—after format conversion and DC offset correction but before echo cancellation (same point as the DC level meter)—over each Meter Timer countdown interval. Automatically loaded at the end of each interval, the meter register must be read low byte first, followed by high byte, unseparated by any other meter access (addresses 0x40 to 0x5F).

7	6	5	4	3	2	1	0
D[23]	D[22]	D[21]	D[20]	D[19]	D[18]	D[17]	D[16]
D[31]	D[30]	D[29]	D[28]	D[27]	D[26]	D[25]	D[24]

**0x48, 0x49—Far-End Level Meter Register (felm\_low, felm\_high)**

A 2-byte read-only register containing 16 MSBs of the 32-bit unsigned far-end level meter accumulator. This meter sums the absolute value of the receive signal path—after echo cancellation but before the DAGC function—over each Meter Timer countdown interval. Automatically loaded at the end of each interval, the meter register must be read low byte first, followed by high byte, unseparated by any other meter access (addresses 0x40 to 0x5F).

7	6	5	4	3	2	1	0
D[23]	D[22]	D[21]	D[20]	D[19]	D[18]	D[17]	D[16]
D[31]	D[30]	D[29]	D[28]	D[27]	D[26]	D[25]	D[24]

### 0x4A, 0x4B—Noise Level Histogram Meter Register (noise\_histogram\_low, noise\_histogram\_high)

A 2-byte read-only register containing all 16 bits of the unsigned noise-level histogram meter accumulator. This meter counts the number of high-noise-level conditions which occur during each Meter Timer countdown interval. A high-noise-level condition is defined as the absolute value of the slicer error signal exceeding (greater than) the threshold specified in the Noise-level Histogram Threshold Register [0x2A, 2B]. Automatically loaded at the end of each countdown interval, the meter register must be read low byte first, followed by high byte, unseparated by any other meter access (addresses 0x40 to 0x5F).

7	6	5	4	3	2	1	0
D[7]	D[6]	D[5]	D[4]	D[3]	D[2]	D[1]	D[0]
D[15]	D[14]	D[13]	D[12]	D[11]	D[10]	D[9]	D[8]

### 0x4C, 0x4D—Bit Error Rate Meter Register (ber\_meter\_low, ber\_meter\_high)

A 2-byte read-only register containing all 16 bits of the unsigned bit-error-rate meter accumulator. This meter counts the number of error-free bits recovered by the detector during each Meter Timer countdown interval. An error-free bit is defined as a match (equal comparison) of the detector's slicer/peak detector output and its scrambler/descrambler output, when operating as a scrambler. When operating as a descrambler, the meter simply counts the number of logic ones produced by the descrambler. The meter register is automatically loaded at the end of each countdown interval, and must be read low byte first, followed by high byte, unseparated by any other meter access (addresses 0x40 to 0x5F).

7	6	5	4	3	2	1	0
D[7]	D[6]	D[5]	D[4]	D[3]	D[2]	D[1]	D[0]
D[15]	D[14]	D[13]	D[12]	D[11]	D[10]	D[9]	D[8]

### 0x4E—Symbol Histogram Meter Register (symbol\_histogram)

A single-byte read-only register containing 8 MSBs of the 16-bit unsigned symbol histogram meter accumulator. This meter counts the number of plus-one or minus-one symbols (+1, -1) detected during each Meter Timer countdown interval. No increment occurs when a plus-three or minus-three symbol (+3, -3) is detected. The meter register is automatically loaded at the end of each countdown interval.

7	6	5	4	3	2	1	0
D[7]	D[6]	D[5]	D[4]	D[3]	D[2]	D[1]	D[0]

### 0x50, 0x51—Noise Level Meter Register (nlm\_low, nlm\_high)

A 2-byte read-only register containing 16 MSBs of the 32-bit unsigned noise-level meter accumulator. This meter sums the absolute value of the detector's slicer-error signal over each Meter Timer countdown interval. Automatically loaded at the end of each interval, the meter register must be read the low byte first, followed by high byte, unseparated by any other meter access (addresses 0x40 to 0x5F).

7	6	5	4	3	2	1	0
D[23]	D[22]	D[21]	D[20]	D[19]	D[18]	D[17]	D[16]
D[31]	D[30]	D[29]	D[28]	D[27]	D[26]	D[25]	D[24]

### 0x5E, 0x5F—PLL Frequency Register (pll\_frequency\_low, pll\_frequency\_high)

A 2-byte read/write register comprising 16 MSBs of the 31-bit, 2's-complement timing recovery loop compensation filter accumulator. Treated much like a meter register, the frequency register must be read low byte first, followed by high byte, unseparated by any other Meter access (addresses 0x40 to 0x5F). Writes must occur in the same order, with the low byte written first, followed by the high byte. Write accesses may be separated by any number of other read or write accesses.

7	6	5	4	3	2	1	0
D[22]	D[21]	D[20]	D[19]	D[18]	D[17]	D[16]	D[15]
D[30]	D[29]	D[28]	D[27]	D[26]	D[25]	D[24]	D[23]

### 0x70—LEC Read Tap Select Register (linear\_ec\_tap\_select\_read)

A 7-bit read/write register representing an unsigned binary address defined over a range of 0 to 119 decimal. When written, it causes the selected 32-bit coefficient of the LEC to be subsequently loaded into the Access Data Register [access\_data\_byte[3:0]; 0x7C–0x7F] within two symbol periods. Does not affect the value of the coefficient. No other data access may occur between the time the Read Tap Select Register is written and the time the Access Data Register is read or the data may be corrupted.

7	6	5	4	3	2	1	0
-	D[6]	D[5]	D[4]	D[3]	D[2]	D[1]	D[0]

### 0x71—LEC Write Tap Select Register (linear\_ec\_tap\_select\_write)

A 7-bit read/write register representing an unsigned binary address defined over a range of 0 to 119 decimal. When written, it causes all 32 bits of the Access Data Register [access\_data\_byte[3:0]; 0x7C–0x7F] to be subsequently written to the selected LEC coefficient within two symbol periods. Does not affect the value of the access data register.

7	6	5	4	3	2	1	0
-	D[6]	D[5]	D[4]	D[3]	D[2]	D[1]	D[0]

**0x72—NEC Read Tap Select Register (nonlinear\_ec\_tap\_select\_read)**

A 6-bit read/write register representing an unsigned binary address defined over a range of 0 to 63 decimals. When written, it causes the selected 14-bit coefficient of the NEC to be subsequently loaded into the lowest-order bits of the Access Data Register [access\_data\_byte[3:0]; 0x7C–0x7F] within two symbol periods. Does not affect the value of the coefficient. No other data access may occur between the time the Read Tap Select Register is written and the time the Access Data Register is read or the data may be corrupted.

7	6	5	4	3	2	1	0
-	-	D[5]	D[4]	D[3]	D[2]	D[1]	D[0]

**0x73—NEC Write Tap Select Register (nonlinear\_ec\_tap\_select\_write)**

A 6-bit read/write register representing an unsigned binary address defined over a range of 0 to 63 decimals. When written, it causes the lowest-order 14 bits of the Access Data Register [access\_data\_byte[3:0]; 0x7C–0x7F] to be subsequently written to the selected NEC coefficient within two symbol periods. Does not affect the value of the access data register.

7	6	5	4	3	2	1	0
-	-	D[5]	D[4]	D[3]	D[2]	D[1]	D[0]

**0x74—DFE Read Tap Select Register (dfe\_tap\_select\_read)**

A 7-bit read/write register representing an unsigned binary address defined over a range of 0 to 113 decimals. When written, it causes the selected 16-bit coefficient of the DFE to be subsequently loaded into the lowest-order bits of the Access Data Register [access\_data\_byte[3:0]; 0x7C–0x7F] within two symbol periods. Does not affect the value of the coefficient. No other data access may occur between the time the Read Tap Select Register is written and the time the Access Data Register is read or the data may be corrupted.

7	6	5	4	3	2	1	0
-	D[6]	D[5]	D[4]	D[3]	D[2]	D[1]	D[0]

**0x75—DFE Write Tap Select Register (dfe\_tap\_select\_write)**

A 7-bit read/write register representing an unsigned binary address defined over a range of 0 to 113 decimals. When written, it causes the lowest-order 16 bits of the Access Data Register [access\_data\_byte[3:0]; 0x7C–0x7F] to be subsequently written to the selected DFE coefficient within two symbol periods. Does not affect the value of the access data register.

7	6	5	4	3	2	1	0
-	D[6]	D[5]	D[4]	D[3]	D[2]	D[1]	D[0]

**0x76—Scratch Pad Read Tap Select (sp\_tap\_select\_read)**

A 6-bit read/write register representing an unsigned binary address defined over a range of 0 to 63 decimals. When written, it causes the selected 8-bit scratch pad memory location to be subsequently loaded into the lowest-order bits of the Access Data Register [access\_data\_byte[3:0]; 0x7C–0x7F] within two symbol periods. Does not affect the value of the memory. No other data access may occur between the time the Read Tap Select Register is written and the time the Access Data Register is read or the data may be corrupted.

7	6	5	4	3	2	1	0
-	-	D[5]	D[4]	D[3]	D[2]	D[1]	D[0]

**0x77—Scratch Pad Write Tap Select (sp\_tap\_select\_write)**

A 6-bit read/write register representing an unsigned binary address defined over a range of 0 to 63 decimals. When written, it causes the lowest-order 8 bits of the Access Data Register [access\_data\_byte[3:0]; 0x7C–0x7F] to be subsequently written to the selected scratch pad memory location within two symbol periods. Does not affect the value of the access data register.

7	6	5	4	3	2	1	0
-	-	D[5]	D[4]	D[3]	D[2]	D[1]	D[0]

**0x78—Equalizer Read Select Register (eq\_add\_read)**

A 6-bit read/write register representing an unsigned binary address defined over a range of 0 to 47 decimals. When written, it causes the selected 16-bit location of the equalizer register file to be subsequently loaded into the lowest-order bits of the Access Data Register [access\_data\_byte[3:0]; 0x7C–0x7F] within two symbol periods. Does not affect the value of the register file location. An address map of the shared register file, as defined by the factory-delivered microcode, is shown below. No other data access may occur between the time the Read Tap Select Register is written and the time the Access Data Register is read or the data may be corrupted.

7	6	5	4	3	2	1	0
-	-	D[5]	D[4]	D[3]	D[2]	D[1]	D[0]

D[5:0]		Stored Parameter
Decimal	Binary	
0–7	00 0000–00 0111	FFE Coefficients 0–7
8–15	00 1000–00 1111	FFE Data Taps 0–7
16–20	01 0000–01 0100	EP Coefficients 0–4
21–25	01 0101–01 1001	EP Data Taps 0–4
26	01 1010	DAGC Gain - Least-Significant Word
27	01 1011	DAGC Gain - Most-Significant Word
28	01 1100	DAGC Output
29	01 1101	FFE Output
30	01 1110	DAGC Input
31	01 1111	FFE Output, Delayed 1 Symbol Period
32	10 0000	DAGC Error Signal
33	10 0001	Equalizer Error Signal
34	10 0010	Slicer Error Signal
35–47	10 0011–10 1111	Reserved

### 0x79—Equalizer Write Select Register (eq\_add\_write)

A 6-bit read/write register representing an unsigned binary address defined over a range of 0 to 47 decimals. When written, it causes the lowest-order 16 bits of the Access Data Register [access\_data\_byte[3:0]; 0x7C–0x7F] to be subsequently written to the selected equalizer register file location within two symbol periods. Does not affect the value of the access data register. An address map of the shared register file, as defined by the factory-delivered microcode, is shown above.

7	6	5	4	3	2	1	0
–	–	D[5]	D[4]	D[3]	D[2]	D[1]	D[0]

### 0x7A—Equalizer Microcode Read Select Register (eq\_microcode\_add\_read)

A 6-bit read/write register representing an unsigned binary address defined over a range of 0 to 63 decimals. When written, it causes the selected 32-bit location of the equalizer microprogram store to be subsequently loaded into the Access Data Register [access\_data\_byte[3:0]; 0x7C–0x7F] within two symbol periods. Does not affect the value of the microprogram store location. No other data access may occur between the time the Read Tap Select Register is written and the time the Access Data Register is read, or the data may be corrupted.

7	6	5	4	3	2	1	0
–	–	D[5]	D[4]	D[3]	D[2]	D[1]	D[0]

**0x7B—Equalizer Microcode Write Select Register (eq\_microcode\_add\_write)**

A 6-bit read/write register representing an unsigned binary address defined over a range of 0 to 63 decimals. When written, it causes all 32 bits of the Access Data Register [access\_data\_byte[3:0]; 0x7C–0x7F] to be subsequently written to the selected equalizer microprogram store location within two symbol periods. Does not affect the value of the access data register. Factory-developed equalizer microcode is included with the no-fee licensed HDSL transceiver software available from Rockwell.

7	6	5	4	3	2	1	0
-	-	D[5]	D[4]	D[3]	D[2]	D[1]	D[0]

**0x7C–0x7F—Access Data Register (access\_data\_byte3:0)**

A 4-byte read/write register stores filter coefficient, equalizer register file, and equalizer microprogram store contents during indirect accesses to these RAM-based locations. Writes to addresses 0x70 through 0x7B, utilize the contents of this shared register as specified in each of the individual register descriptions.

Preliminary Review

11/29/00 10:00 A.M.

## 5.0 Electrical & Mechanical Specifications

### 5.1 Absolute Maximum Ratings

Stresses above those listed may cause permanent damage to the device. This is a stress rating only. Functional operation of the device at these or any other conditions beyond those listed in the operational sections of this specification is not implied. Exposure to absolute maximum rating conditions for extended periods may affect device reliability.

Table 5-1. Absolute Maximum Ratings

Symbol	Parameter	Minimum	Maximum	Units
$V_{\text{Supply}}$	Supply Voltage <sup>(1)</sup>	-0.5	+7	V
$V_{\text{I}}$	Input Voltage on any Signal Pin <sup>(2)</sup>	-0.5	$V_{\text{DD2}} + 0.5$	V
$T_{\text{ST}}$	Storage Temperature	-65	+125	°C
$T_{\text{VSOL}}$	Vapor-Phase Soldering Temperature (1 minute)	—	+220	°C

1.  $V_{\text{DD1}}$ ,  $V_{\text{DD2}}$ , relative to DGND.  $V_{\text{AA}}$  relative to AGND.  
2. Relative to DGND.

## 5.2 Recommended Operating Conditions

Table 5-2. Recommended Operating Conditions

Symbol	Parameter	Minimum	Typical	Maximum	Units
$V_{DD1}$	Digital Core-Logic Supply Voltage (+5 V)	4.75	5.0	5.25	V
$V_{DD1}$	Digital Core-Logic Supply Voltage (+3.3 V)	3.0	3.3	3.6	V
$V_{DD2}$	Digital I/O-Buffer Supply Voltage	4.75	5.0	5.25	V
$V_{AA}$	Analog Supply Voltage	4.75	5.0	5.25	V
$V_{IH}$	High-Level Input Voltage	2.0	—	$V_{DD2} + 0.3$	V
$V_{IL}$	Low-Level Input Voltage	-0.3	—	+0.8	V
$V_{IHx}$	High-Level Input Voltage for XTALI / MCLK	$0.8 \cdot V_{DD2}$	—	$V_{DD2} + 0.3$	V
$V_{ILx}$	Low-Level Input Voltage for XTALI / MCLK	-0.3	—	$0.2 \cdot V_{DD2}$	V
$C_L$	Output Capacitive Loading <sup>(1)</sup>	—	—	60	pF
$T_A$	Ambient Operating Temperature <sup>(2)</sup>	-40	—	+85	°C

**NOTE(S):**

- Capacitive loading over which all digital output switching characteristics are guaranteed.
- Still-air temperature range over which all electrical characteristics and timing requirements/characteristics are guaranteed.

## 5.3 Electrical Characteristics

Typical characteristics measured at nominal operating conditions:  $T_A = 25\text{ }^\circ\text{C}$ ;  
 $V_{DD/AA} = 5.0\text{ V}$  minimum/maximum characteristics guaranteed over extreme  
operating conditions:  $\min \leq T_A \leq \max$ ;  $\min \leq V_{DD/AA} \leq \max$ .

Table 5-3. Electrical Characteristics

Symbol	Parameter	Minimum	Typical	Maximum	Units
$V_{OH}$	High-Level Output Voltage @ $I_{OH} = -400\text{ }\mu\text{A}$	2.4	—	—	V
$V_{OLL}$	Low-Level Output Voltage @ $I_{OL} = 6\text{ mA}$ ( $\overline{\text{IRQ}}$ and $\overline{\text{READY}}$ )	—	—	0.4	V
$V_{OL}$	Low-Level Output Voltage @ $I_{OL} = 3\text{ mA}$ (All Other Outputs)	—	—	0.4	V
$I_I$	Input Leakage Current @ $V_{SS2} \leq V_I \leq V_{DD2}$	—	—	$\pm 10$	$\mu\text{A}$
$I_{OZ}$	High-Impedance Output Leakage Current @ $V_{SS2} \leq V_O \leq V_{DD2}$	—	—	$\pm 10$	$\mu\text{A}$
$I_{PR}$	Resistive Pull-Up Current @ $V_I = V_{SS2}$ (TDI and TMS)	-100	—	-800	$\mu\text{A}$
$I_{5VTOT}$	Total Supply Current @ $F_{OCLK} = 80\text{ kHz}^{(1)}$	—	TBD	126	mA
$I_{5VTOT}$	Total Supply Current @ $F_{OCLK} = 584\text{ kHz}^{(1)}$	—	TBD	246	mA
$I_{5VPART}$	Partial Supply Current @ $F_{OCLK} = 80\text{ kHz}^{(2)}$	—	TBD	104	mA
$I_{5VPART}$	Partial Supply Current @ $F_{OCLK} = 584\text{ kHz}^{(2)}$	—	TBD	119	mA
$I_{3V}$	$V_{DD1}$ Supply Current @ $F_{OCLK} = 80\text{ kHz}^{(3)}$	—	TBD	13	mA
$I_{3V}$	$V_{DD1}$ Supply Current @ $F_{OCLK} = 584\text{ kHz}^{(3)}$	—	TBD	81	mA
$I_{PD}$	Total Power-Down Current @ $F_{OCLK} = 80\text{ kHz}^{(4)}$	—	TBD	—	mA
$I_{PD}$	Total Power-Down Current @ $F_{OCLK} = 584\text{ kHz}^{(4)}$	—	TBD	—	mA
$C_I$	Input Capacitance	—	10	—	pF
$C_{OZ}$	High-Impedance Output Capacitance	—	10	—	pF
<p><b>NOTE(S):</b></p> <ol style="list-style-type: none"> <li><math>I_{5VTOT} = I_{DD1} + I_{DD2} + I_{AA}</math> during normal operation.</li> <li><math>I_{5VPART} = I_{DD2} + I_{AA}</math> during normal operation.</li> <li><math>I_{3V} = I_{DD1}</math> during normal operation using 3.3 V.</li> <li><math>I_{TOTAL} = I_{DD1} + I_{DD2} + I_{AA}</math> during power-down operation.</li> </ol>					

## 5.4 Clock Timing

Table 5-4. External Clock Timing Requirements (MCLK)

Symbol	Parameter	Minimum	Maximum	Units
1	MCLK Period ( $T_{MCLK}$ ) <sup>(1)</sup>	80	782	ns
2	MCLK Pulse-Width Low	30	—	ns
3	MCLK Pulse-Width High	30	—	ns

Note:(1).If an external clock is applied to XTALI/MCLK, it is referred to as MCLK.

Figure 5-1. MCLK Timing Requirements

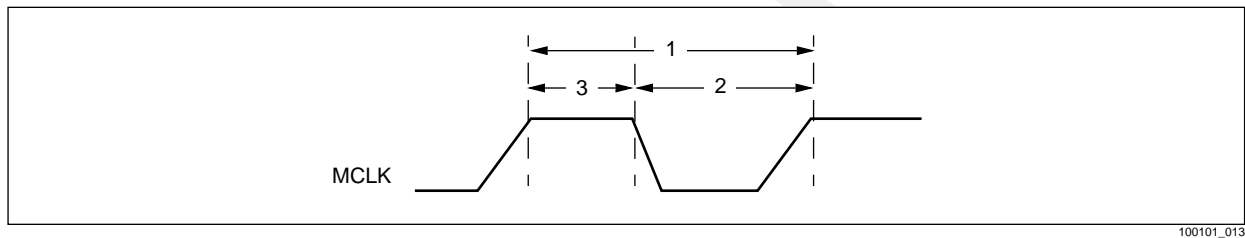

Table 5-5. HCLK Switching Characteristics

Symbol	Parameter	Minimum	Typical	Maximum	Units
4	HCLK Period ( $T_{HCLK}$ ), hclk_freq[1:0] = '11' (N=6) <sup>(1)</sup>	$T_{OCLK} \div 64$	$T_{OCLK} \div 64$	$T_{OCLK} \div 64$	—
5	HCLK Period ( $T_{HCLK}$ ), hclk_freq[1:0] = '00' or '01' (N=2) <sup>(1)</sup>	$T_{OCLK} \div 16$	$T_{OCLK} \div 16$	$T_{OCLK} \div 16$	—
6	HCLK Period ( $T_{HCLK}$ ), hclk_freq[1:0] = '10' (N=4) <sup>(1)</sup>	$T_{OCLK} \div 32$	$T_{OCLK} \div 32$	$T_{OCLK} \div 32$	—
7	HCLK Pulse-Width High	$T_{HCLK} \div 2 - 10$	$T_{HCLK} \div 2$	$T_{HCLK} \div 2 + 10$	ns
8	HCLK Pulse-Width Low	$T_{HCLK} \div 2 - 10$	$T_{HCLK} \div 2$	$T_{HCLK} \div 2 + 10$	ns

<sup>(1)</sup> The hclk\_freq[1:0] control bits are located in the Serial Monitor Source Select Register [addr. 0x01].

Table 5-6. Symbol Clock (QCLK) Switching Characteristics

Symbol	Parameter	Minimum	Maximum	Units
9	QCLK Period ( $T_{QCLK}^{(1)}$ )	$K \times T_{HCLK}$	$K \times T_{HCLK}$	—
10	QCLK Pulse-Width High	$T_{QCLK} \div 2 - 20$	$T_{QCLK} \div 2 + 20$	ns
11	QCLK Pulse-Width Low	$T_{QCLK} \div 2 - 20$	$T_{QCLK} \div 2 + 20$	ns
12	QCLK Hold after HCLK Rising Edge	-20	—	—
13	QCLK Delay after HCLK High	—	20	—

(1) K = 16, 32, or 64 according to hclk\_freq[1,0]. QCLK can be frequency locked to the incoming data symbol rate.

Figure 5-2. Clock Control Timing

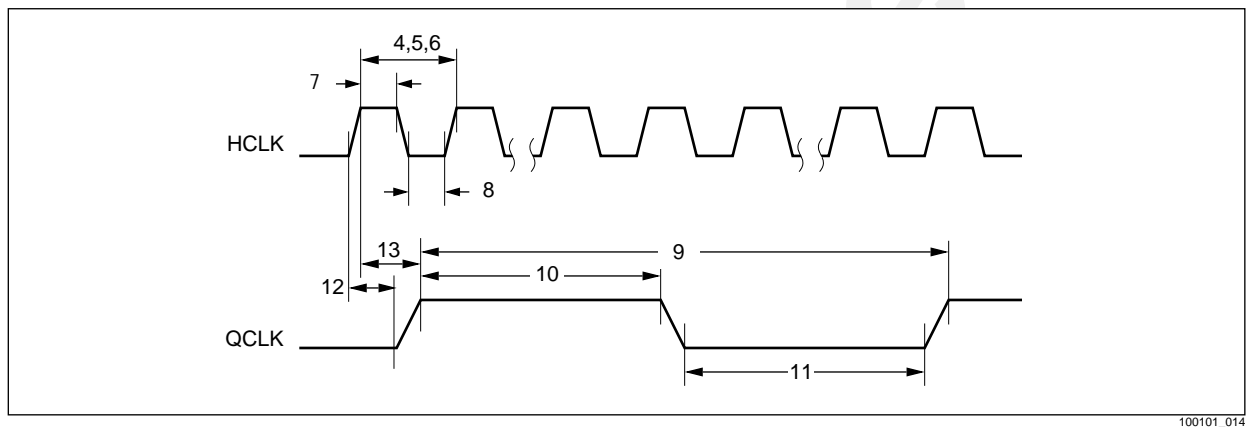

## 5.5 Channel Unit Interface Timing

Table 5-7. Channel Unit Interface Timing Requirements, Parallel Master Mode

Symbol	Parameter	Minimum	Maximum	Units
14	TQ[1,0] Setup prior to QCLK Falling Edge	100	—	ns
15	TQ[1,0] Hold after QCLK Low	25	—	ns

Table 5-8. Channel Unit Interface Switching Characteristics, Parallel Master Mode

Symbol	Parameter	Minimum	Maximum	Units
16	RQ[1,0] Hold after QCLK Rising Edge	-50	—	ns
17	RQ[1,0] Delay after QCLK High	—	50	ns

Figure 5-3. Channel Unit Interface Timing, Parallel Master Mode

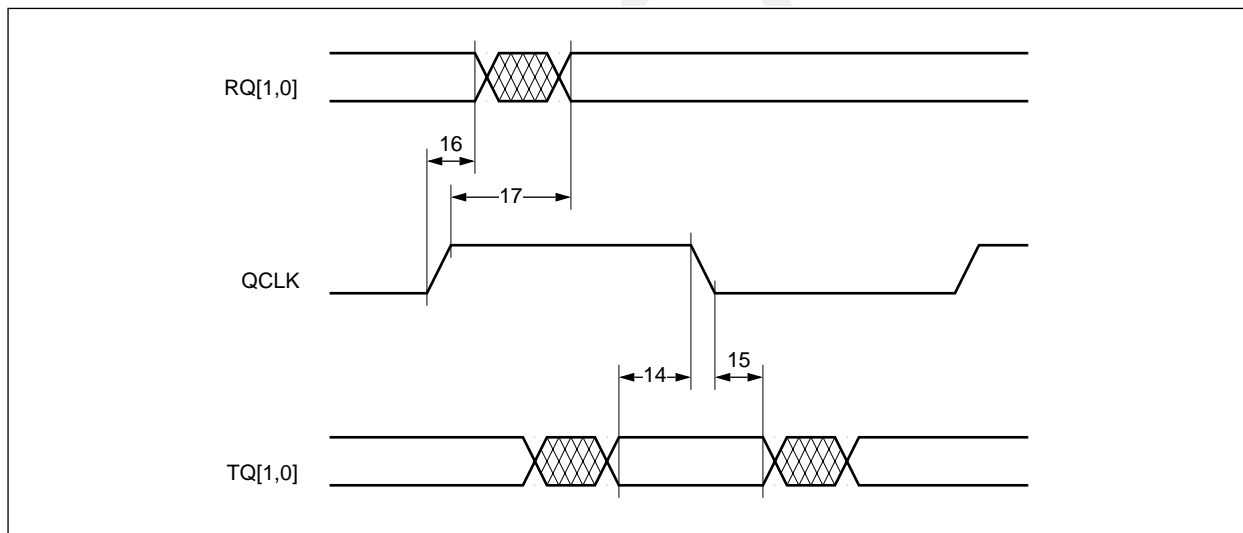

Table 5-9. Channel-Unit Interface Timing Requirements, Parallel Slave Mode

Symbol	Parameter	Minimum	Maximum	Units
18	TBCLK, RBCLK Period <sup>(1)</sup>	$T_{OCLK}$	$T_{OCLK}$	—
19	TBCLK, RBCLK Pulse-Width High	$T_{OCLK} \div 4$	—	—
20	TBCLK, RBCLK Pulse-Width Low	$T_{OCLK} \div 4$	—	—
21	TQ[1,0] Setup prior to TBCLK Active Edge <sup>(2)</sup>	25	—	ns
22	TQ[1,0] Hold after TBCLK High/Low <sup>(2)</sup>	25	—	ns

**NOTE(S):**  
 (1) TBCLK and RBCLK must be frequency locked to QCLK though they may have independent phase relationships to QCLK and to one another.  
 (2) TBCLK polarity (edge sensitivity) is programmable through the CU Interface Modes Register [cu\_interface\_modes 0x06].

Table 5-10. Channel Unit Interface Switching Characteristics, Parallel Slave Mode

Symbol	Parameter	Minimum	Maximum	Units
23	RQ[1,0] Hold after RBCLK Active Edge <sup>(1)</sup>	0	—	ns
24	RQ[1,0] Delay after RBCLK High/Low <sup>(1)</sup>	—	100	ns

**NOTE(S):**  
 1. RBCLK polarity (edge sensitivity) is programmable through the CU Interface Modes Register [cu\_interface\_modes; 0x06].

Figure 5-4. Channel Unit Interface Timing, Parallel Slave Mode

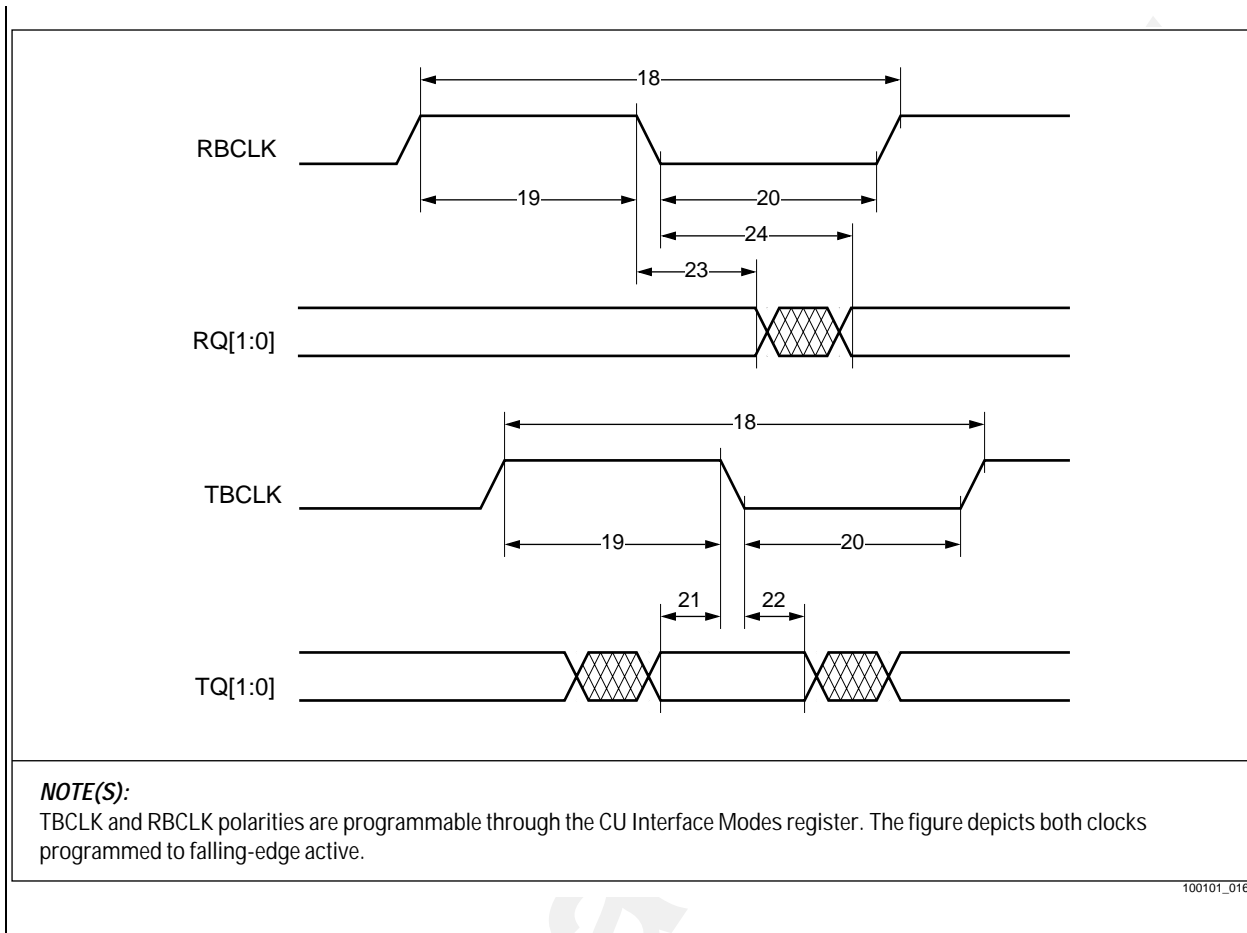

Table 5-11. Channel Unit Interface Timing Requirements, Serial Mode

Symbol	Parameter	Minimum	Maximum	Units
25	TDAT Setup prior to BCLK Falling Edge	100	—	ns
26	TDAT Hold after BCLK Low	25	—	ns

Table 5-12. Channel Unit Interface Switching Characteristics, Serial Mode

Symbol	Parameter	Minimum	Maximum	Units
27	BCLK Period	$T_{OCLK} \div 2$	$T_{OCLK} \div 2$	—
28	BCLK Pulse-Width High	$T_{OCLK} \div 4 - 20$	$T_{OCLK} \div 4 + 20$	ns
29	BCLK Pulse-Width Low	$T_{OCLK} \div 4 - 20$	$T_{OCLK} \div 4 + 20$	ns
30	BCLK Hold after HCLK Rising Edge	0	—	ns
31	BCLK Delay after HCLK High	—	50	ns
32	RDAT, QCLK Hold after BCLK Rising Edge	-50	—	ns
33	RDAT, QCLK Delay after BCLK High	—	50	ns

Figure 5-5. Channel Unit Interface Timing, Serial Mode

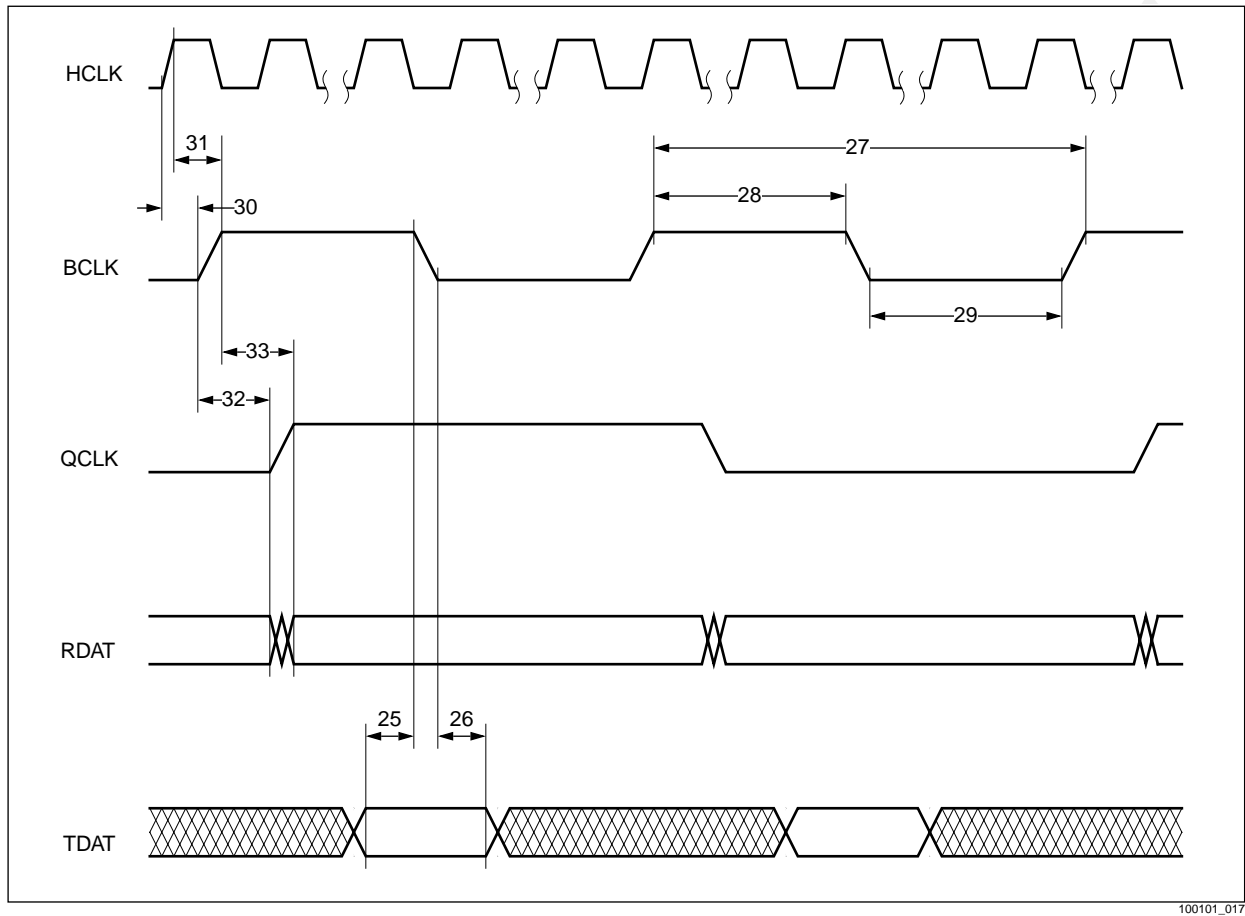

11/29/00 10:00 A.M.

## 5.6 Microcomputer Interface Timing

Table 5-13. Microcomputer Interface Timing Requirements

Symbol	Parameter	Minimum	Maximum	Units
34	ALE Pulse-Width High	30	—	ns
35	Address Setup prior to ALE Falling Edge <sup>(1)</sup>	12	—	ns
36	Address Hold after ALE Low <sup>(1)</sup>	5	—	ns
37	ALE low prior to $\overline{\text{Write Strobe}}$ Falling Edge <sup>(2)</sup>	20	—	ns
38	ALE low prior to $\overline{\text{Read Strobe}}$ Falling Edge <sup>(3,4)</sup>	-27	—	ns
39	$\overline{\text{Write Strobe}}$ Pulse-Width Low <sup>(2,5)</sup>	$0.5 \cdot T_{mclk} + 25$	—	ns
40	$\overline{\text{Read Strobe}}$ Pulse-Width Low <sup>(3,5)</sup>	$0.5 \cdot T_{mclk} + 25$	—	ns
41	Data In Setup prior to $\overline{\text{Write Strobe}}$ Rising Edge <sup>(2)</sup>	30	—	ns
42	Data In Hold after $\overline{\text{Write Strobe}}$ High <sup>(2)</sup>	5	—	ns
43	$R/\overline{W}$ Setup prior to $\overline{\text{Read/Write Strobe}}$ Falling Edge	10	—	ns
44	$R/\overline{W}$ Hold after $\overline{\text{Read/Write Strobe}}$ High	10	—	ns
45	ALE Falling Edge after $\overline{\text{Write Strobe}}$ High	20	—	ns
46	ALE Falling Edge after $\overline{\text{Read Strobe}}$ High	20	—	ns
47	$\overline{\text{RST}}$ Pulse-Width Low	50	—	ns
48	$\overline{\text{Write Strobe}}$ Rising Edge after $\overline{\text{READY}}$ low	0	—	ns

**NOTE(S):**

- Address is defined as AD[7:0] when MUXED = 1, and ADDR[7:0] when MUXED = 0.
- In Intel mode,  $\overline{\text{Write Strobe}}$  is defined as  $\overline{\text{WR}}$  and  $\overline{\text{CS}}$  asserted. In Motorola mode, it is defined as  $\overline{\text{DS}}$  and  $\overline{\text{CS}}$  asserted when  $R/\overline{W}$  is low.
- In Intel mode,  $\overline{\text{Read Strobe}}$  is defined as  $\overline{\text{RD}}$  and  $\overline{\text{CS}}$  asserted. In Motorola mode, it is defined as  $\overline{\text{DS}}$  and  $\overline{\text{CS}}$  asserted when  $R/\overline{W}$  is high.
- Parameter 38 is -27 ns only if separate address and data busses are used (i.e., muxed = 0). If muxed = 1, then parameter 38 is 20 ns.
- The timing listed is for the synchronous mode of the MCI. It can also be set to asynchronous mode by setting bit 0 of the reserved2 register (address 0x0F) to a 1. In this case the minimum timing changes to 40 us for symbol 39, and 50 ns for symbols 40 and 50. Synchronous mode is preferred because it reduces internal switching noise, however no significant performance degradation has been measured as a result of using the asynchronous mode.

Table 5-14. Microcomputer Interface Switching Characteristics

Symbol	Parameter	Minimum	Maximum	Units
49	Data Out Enable (Low Z) after $\overline{\text{Read Strobe}}$ Falling Edge <sup>(1)</sup>	2	—	ns
50	Data Out Valid after $\overline{\text{Read Strobe}}$ Low <sup>(1, 7)</sup>	—	0.5 * Tmclk + 25	ns
51	Data Out Hold after $\overline{\text{Read Strobe}}$ Rising Edge <sup>(1)</sup>	2	—	ns
52	Data Out Disable (High Z) after $\overline{\text{Read Strobe}}$ High <sup>(1)</sup>	—	25	ns
53	$\overline{\text{IRQ}}$ Hold after $\overline{\text{Write Strobe}}$ Rising Edge <sup>(2,3)</sup>	5	—	ns
54	$\overline{\text{IRQ}}$ Delay after $\overline{\text{Write Strobe}}$ High <sup>(2,3)</sup>	—	Tqclk ÷ 32 + 20	ns
55	Internal Register Delay after $\overline{\text{Write Strobe}}$ High <sup>(3,4)</sup>	—	Tqclk ÷ 32	ns
56	Internal RAM Delay after $\overline{\text{Write Strobe}}$ High <sup>(3,5)</sup>	—	2 * Tqclk	ns
57	Access Data Register Delay after $\overline{\text{Write Strobe}}$ High <sup>(3,6)</sup>	—	2 * Tqclk	ns
58	$\overline{\text{READY}}$ Falling Edge after $\overline{\text{Write Strobe}}$ Low <sup>(3)</sup>	0	0.5 * Tmclk + 25	ns
59	$\overline{\text{READY}}$ Rising Edge after $\overline{\text{Write Strobe}}$ High <sup>(3)</sup>	0	50	ns
60	$\overline{\text{READY}}$ Falling Edge after $\overline{\text{Read Strobe}}$ Low <sup>(1)</sup>	0	0.5 * Tmclk + 25	ns
61	$\overline{\text{READY}}$ Rising Edge after $\overline{\text{Read Strobe}}$ High <sup>(1)</sup>	0	50	ns
62	Data Out Valid after $\overline{\text{READY}}$ low	—	10	ns

**NOTE(S):**

1. Read Strobe is defined as  $\overline{\text{RD}}$  and  $\overline{\text{CS}}$  asserted in Intel mode, and  $\overline{\text{DS}}$  and  $\overline{\text{CS}}$  asserted when  $\overline{\text{R/W}}$  is high in Motorola mode.
1. When writing an interrupt mask or status register.
2. Write Strobe is defined as  $\overline{\text{WR}}$  and  $\overline{\text{CS}}$  asserted in Intel mode, and  $\overline{\text{DS}}$  and  $\overline{\text{CS}}$  asserted when  $\overline{\text{R/W}}$  is low in Motorola mode.
3. Writes to internal registers are synchronized to an internal 64-times symbol-rate clock. Data is available for reading after the specified time. This parameter may extend the overall read access time from internal register locations under high bus speed/low symbol rate conditions.
4. When performing an indirect write to RAM-based locations using a write select register [odd addresses: 0x71–0x7B] and the Access Data Register. Subsequent writes to any read/write select register or the Access Data Register, as initiated by a  $\overline{\text{Write Strobe}}$  falling edge, is prohibited for the specified time. This parameter will extend the overall write access time to RAM-based locations under normal bus speed/symbol rate conditions.
5. When performing an indirect read from RAM-based locations using a read select register [even addresses: 0x70–0x7A] and the Access Data Register. Subsequent writes to any read/write select register, as initiated by a  $\overline{\text{Write Strobe}}$  falling-edge, is prohibited for the specified time. Data is available for reading from the Access Data Register after the specified time. This parameter will extend the overall read access time from RAM-based locations under normal bus speed/symbol rate conditions. Direct writes to the Access Data Register are as specified for internal registers.
6. The timing listed is for the synchronous mode of the MCI. It can also be set to asynchronous mode by setting bit 0 of the reserved2 register (address 0x0F) to a 1. In this case the minimum timing changes to 40 us for symbol 39, and 50 ns for symbols 40 and 50. Synchronous mode is preferred because it reduces internal switching noise, however no significant performance degradation has been measured as a result of using the asynchronous mode.

Figure 5-6. MCI Write Timing, Intel Mode (MOTEL = 0)

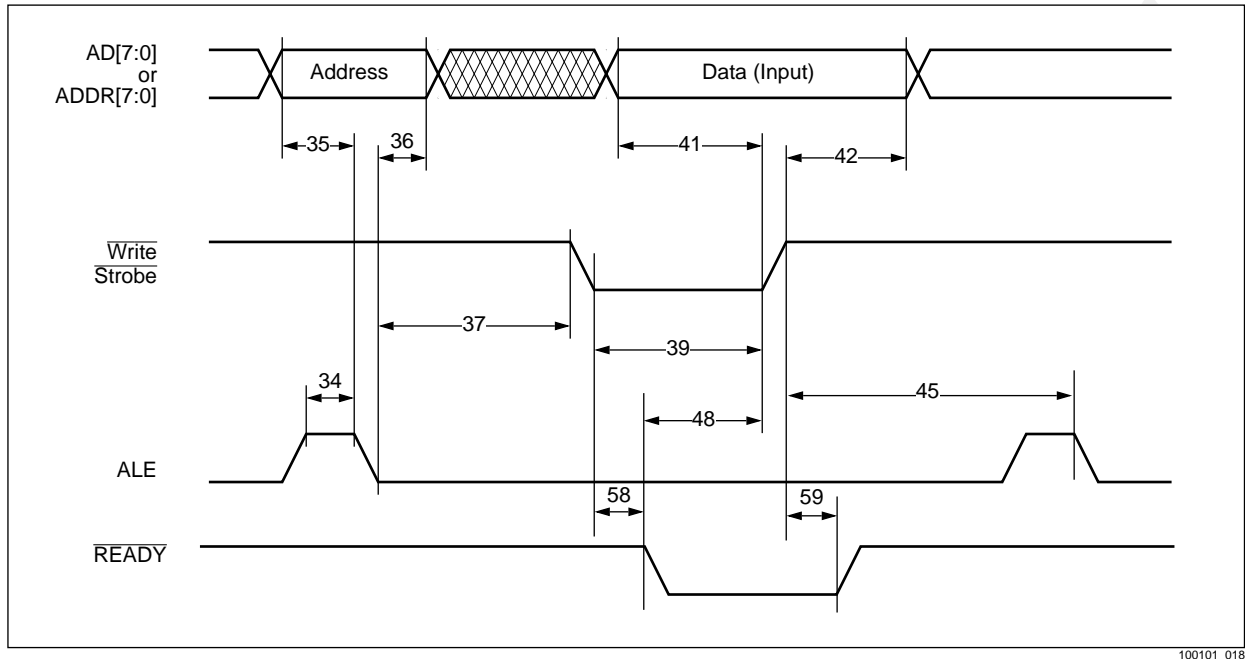

100101\_018

Figure 5-7. MCI Write Timing, Motorola Mode (MOTEL = 1)

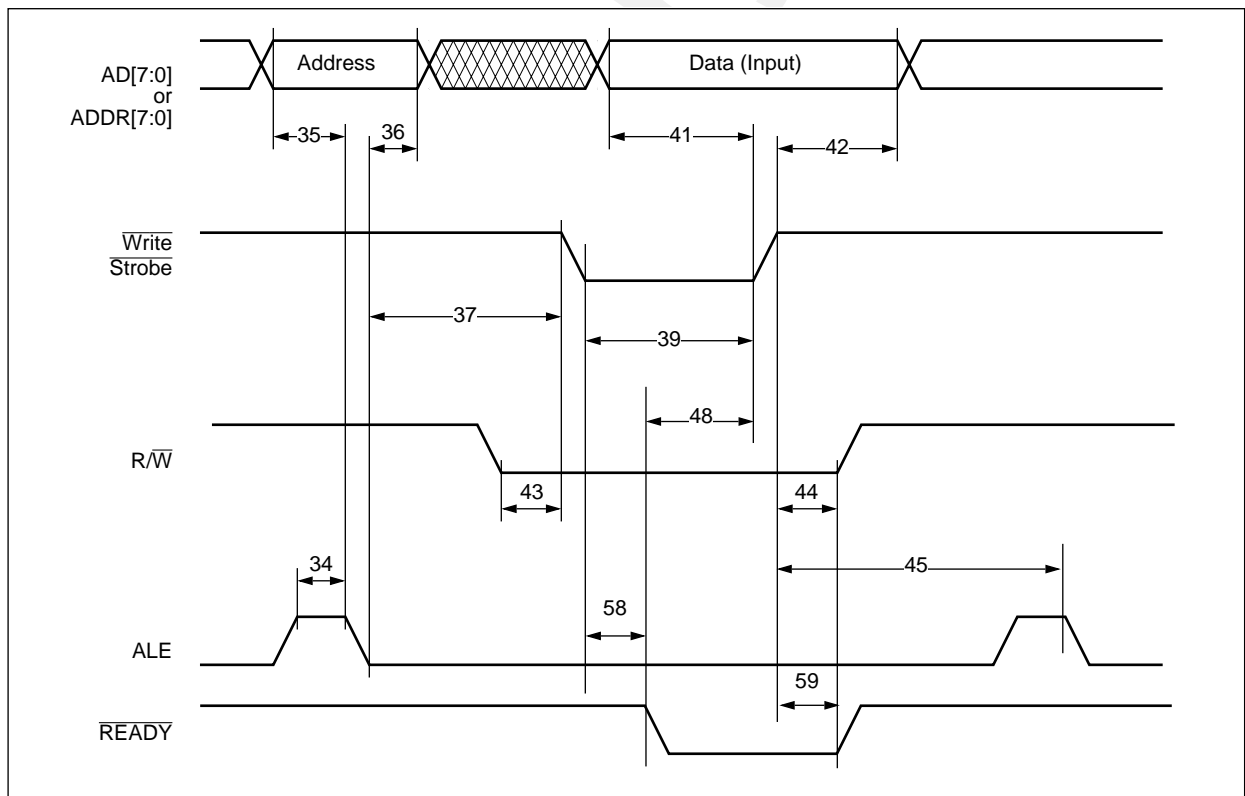

100101\_019

Figure 5-8. MCI Read Timing, Intel Mode (MOTEL = 0)

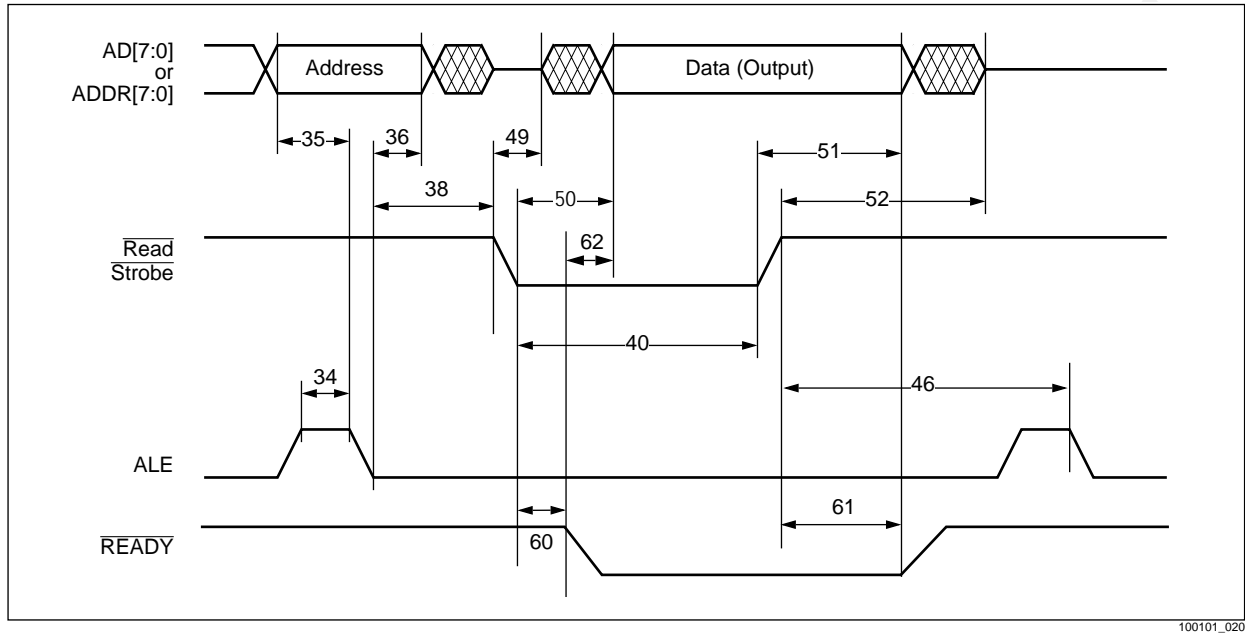

100101\_020

Preliminary

11/29/00 10:00 A.M.

Figure 5-9. MCI Read Timing, Motorola Mode (MOTEL = 1)

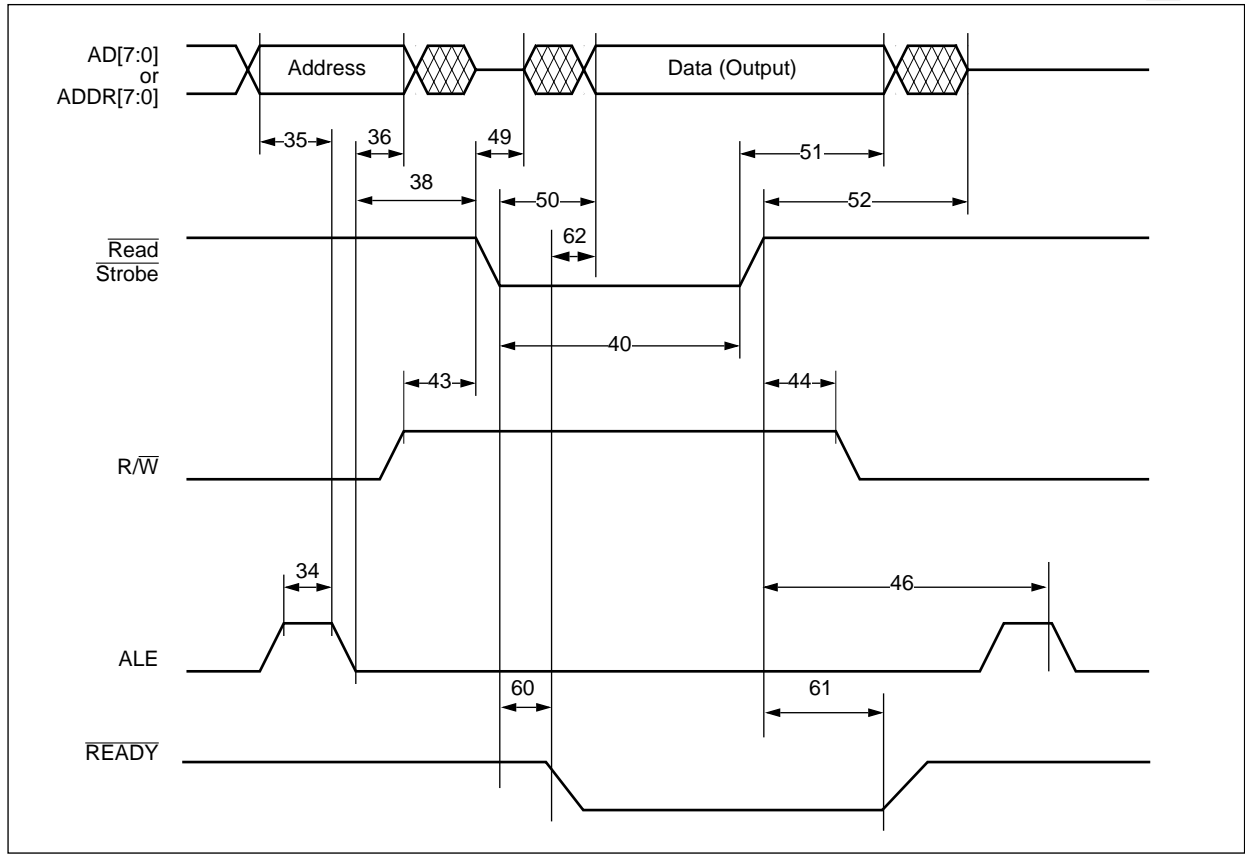

11/29/00 10:00 A.M.

Figure 5-10. Internal Write Timing

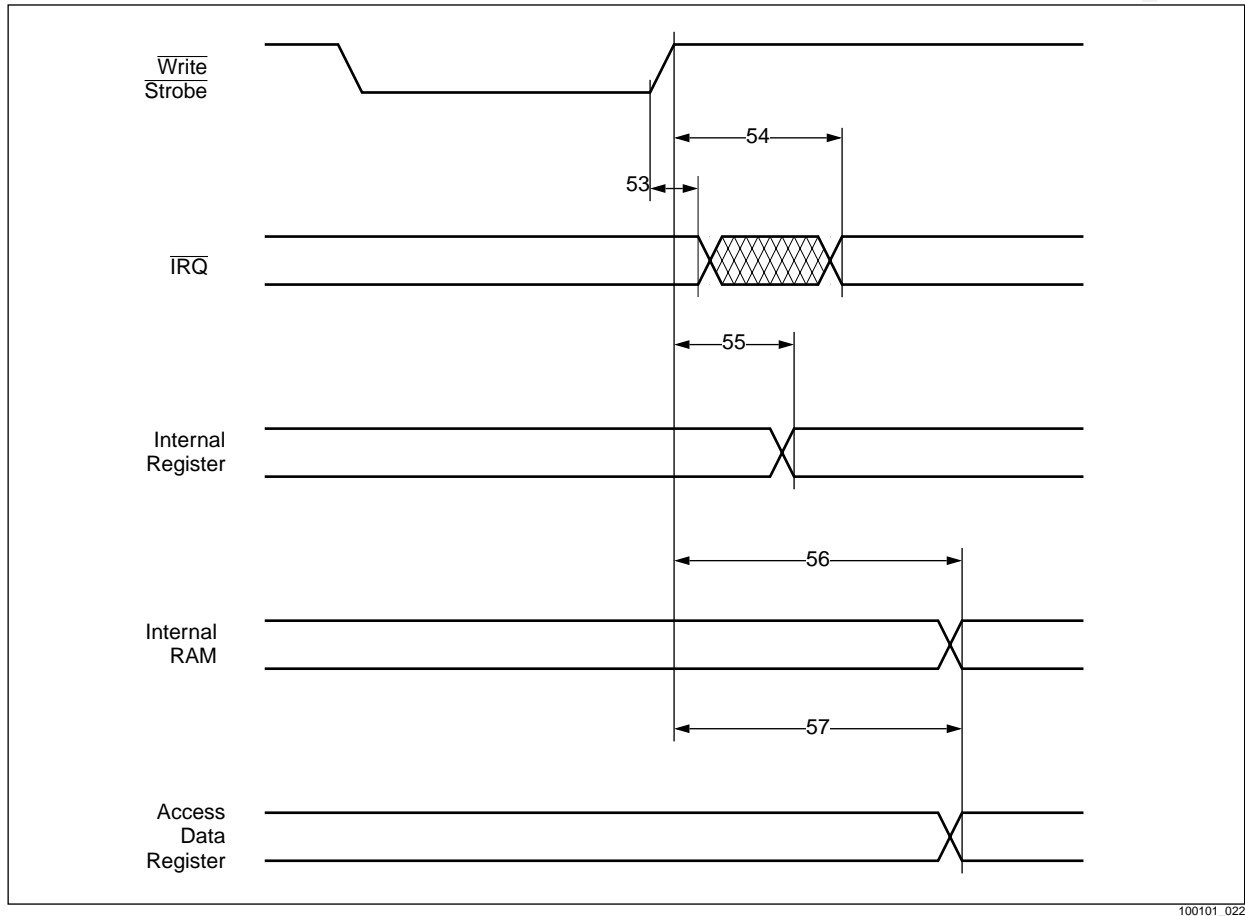

### 5.6.1 Test and Diagnostic Interface Timing

Table 5-15. Test and Diagnostic Interface Timing Requirements

Symbol	Parameter	Minimum	Maximum	Units
63	TCK Pulse-Width High	80	—	ns
64	TCK Pulse-Width Low	80	—	ns
65	TMS, TDI Setup prior to TCK Rising Edge <sup>(1)</sup>	20	—	ns
66	TMS, TDI Hold after TCK High <sup>(1)</sup>	20	—	ns

**NOTE(S):**  
 1. Also applies to functional inputs for SAMPLE/PRELOAD and EXTEST instructions.

Table 5-16. Test and Diagnostic Interface Switching Characteristics

Symbol	Parameter	Minimum	Maximum	Units
67	TDO Hold after TCK Falling Edge <sup>(1)</sup>	0	—	ns
68	TDO Delay after TCK Low <sup>(1)</sup>	—	50	ns
69	TDO Enable (Low Z) after TCK Falling Edge <sup>(1)</sup>	2	—	ns
70	TDO Disable (High Z) after TCK Low <sup>(1)</sup>	—	25	ns
71	SMON Hold after HCLK Rising Edge <sup>(2)</sup>	0	—	ns
72	SMON Delay after HCLK High <sup>(2)</sup>	—	50	ns

**NOTE(S):**  
 1. Also applies to functional outputs for the EXTEST instruction.  
 2. HCLK must be programmed to operate at 16 times the symbol rate ( $16 \times F_{OCLK}$ ).

Figure 5-11. JTAG Interface Timing

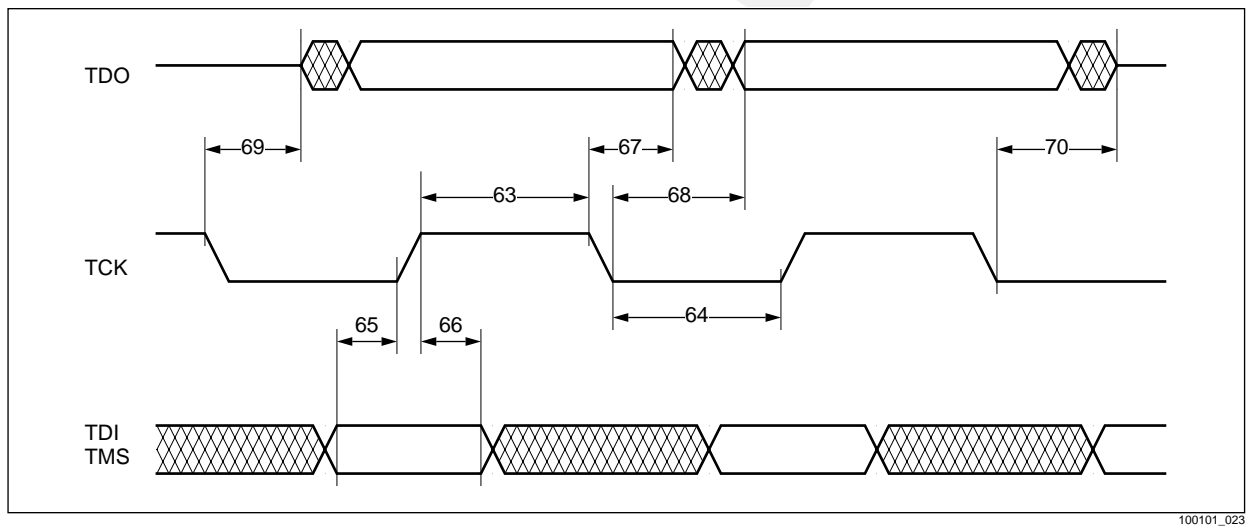
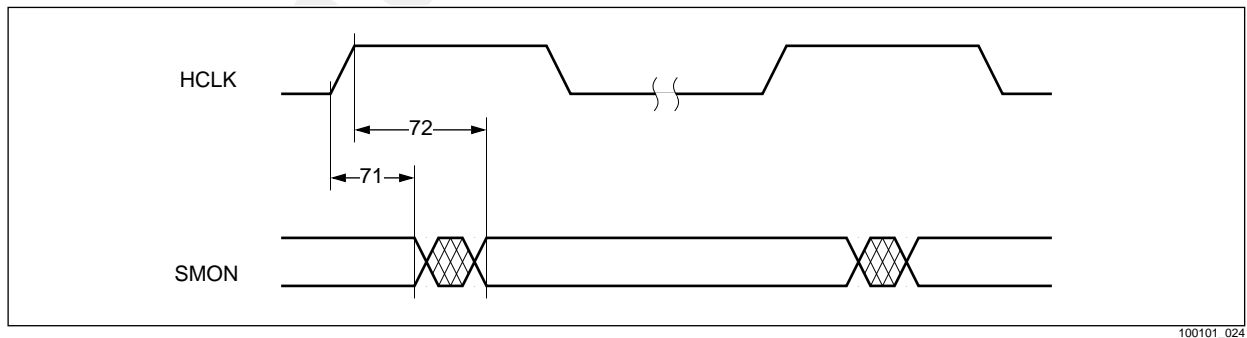

Figure 5-12. SMON Timing



## 5.6.2 Analog Specifications

Table 5-17. Receiver Analog Requirements and Specifications

Parameter	Comments	Min	Typ	Max	Units
Input Signals	RXP, RXN, RXBP, and RXBN	—	—	—	—
Input Voltage Range	Balanced Differential	-4.5		+4.5	V
Input Resistance	DC to 1 MHz	TBD			k $\Omega$
Common Mode Voltage	VCOMI		0.4*VAA		—
Variable Gain Amplifier (VGA)	Six gains from 0 dB to +15 dB				—
Gain Step		2.55	3.0	3.42	dB
Gain Error				$\pm 10$	%
Analog-to-Digital Converter			—	—	—
Output Symbol Rate (F <sub>OCLK</sub> )	QCLK frequency (Data Rate/2)	200	—	584	kHz
Differential Voltage Range (Full Scale Input, FS) <sup>(1)</sup>	(V <sub>RXP</sub> -V <sub>RXN</sub> )-(V <sub>RXBP</sub> -V <sub>RXBN</sub> )	5.4	6.0	6.6	V <sub>p</sub>
Timing Recovery PLL Pull-In Range		$\pm 64$	—	—	ppm
<p><b>NOTE(S):</b></p> <p>1. Corresponds to the voltages that will produce a full scale reading from the ADC when the VGA gain equals 0 dB. Input voltage range is reduced proportionally as VGA gain is increased.</p>					

Table 5-18. Transmitter Analog Requirements and Specifications

Parameter	Comments	Min	Typ	Max	Units
Transmit Symbol Rate ( $f_{\text{qclk}}$ )	QCLK Frequency (Data Rate/2)	200	—	584	kHz
Pulse Template <sup>(1, 2, 3)</sup>	See Figure 5-13, $R_L = 135 \Omega$	—	—	—	—
Average Power <sup>(1, 2, 4)</sup>	DC to $2 \times F_{\text{QCLK}}$ , $R_L = 135 \Omega$ , 0dB gain setting	13.4	—	14.0	dBm
Gain Adjustment Step	Controlled by Transmit Gain Register [0x29]. Seven steps above and eight steps below 0 dB.	0.17	0.20	0.24	dB
Output Referred Offset Voltage		—	—	25	mV
Output Current		125	—	—	mA
Common-Mode Voltage	VCOMO		VAA/2	—	V
Output Impedance <sup>(7)</sup>	DC to 1 MHz	—	—	2	$\% \Omega$
Linearity	At Output Symbol Peak	—	0.01	—	%FSR <sup>(5)</sup>
Harmonic Distortion	3 kHz, 3.4 V Peak Sine Wave Output, $R_L = 0 \Omega$	—	-70	—	dB

**NOTE(S):**

- Guaranteed by design and characterization.
- See 5-14 of the Test Conditions section of this datasheet for test circuit.
- Measured after the transmitter is calibrated by writing the value in the Transmitter Calibration Register [tx\_calibrate; 0x28] to the Transmitter Gain Register [tx\_gain; 0x29].
- Measured with a pseudo-random code sequence of pulses.
- FSR is Full Scale Range.

Figure 5-13. Transmitted Pulse Template

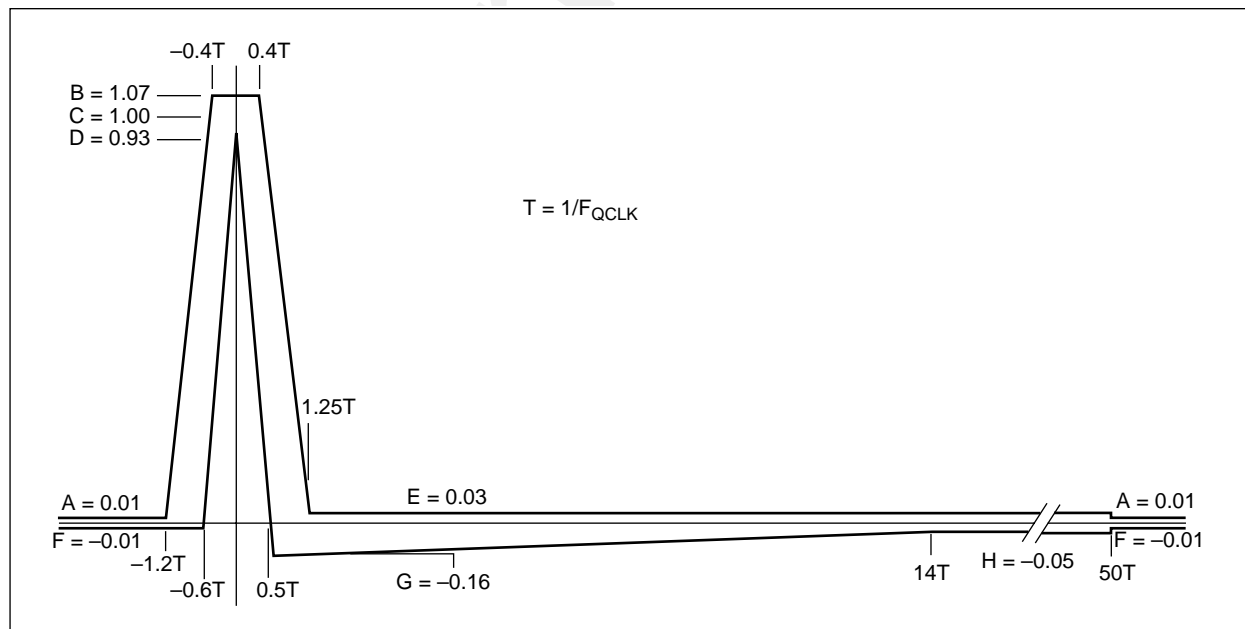
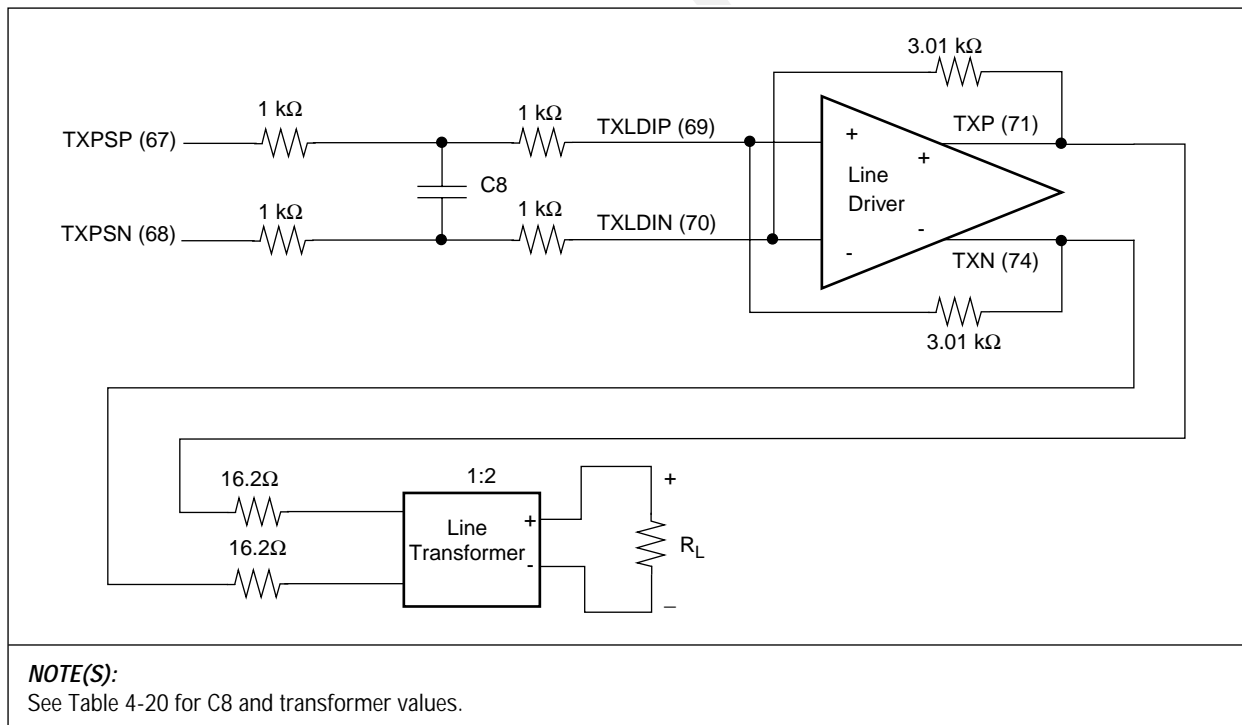

Table 5-19. Transmitted Pulse Template

Normalized Level		Quaternary Symbols			
		+3	+1	-1	-3
A	0.01	0.0264	0.0088	-0.0088	-0.0264
B	1.07	2.8248	0.9416	-0.9416	-2.8248
C	1.00	2.6400	0.8800	-0.8800	-2.6400
D	0.93	2.4552	0.8184	-0.8184	-2.4552
E	0.03	0.0792	0.0264	-0.0264	-0.0792
F	-0.01	-0.0264	-0.0088	0.0088	0.0264
G	-0.16	-0.4224	-0.1408	0.1408	0.4224
H	-0.05	-0.1320	-0.0440	0.0440	0.1320

### 5.6.3 Test Conditions

Figure 5-14. Transmitter Test Circuit



100101\_026

Table 5-20. Transmitter Test Circuit Component Values

Component	Data Rate	
	784 kbps	1168 kbps
C8	680 pF	470 pF
L (Primary Inductance - Line Side)	3.0 mH	2.0 mH

Figure 5-15. Standard Output Load (Totem Pole and Three-State Outputs)

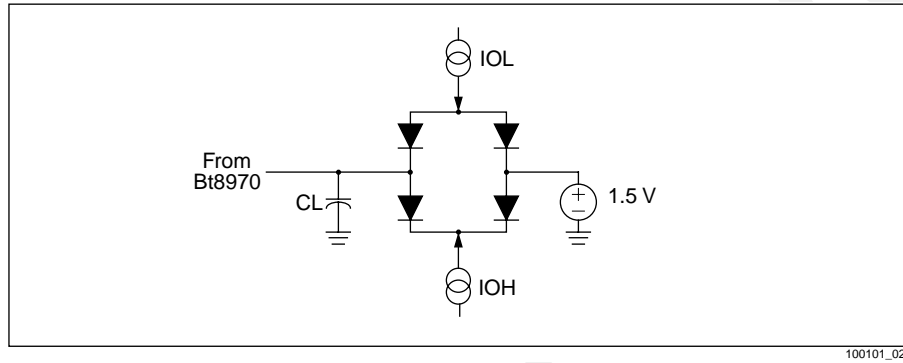
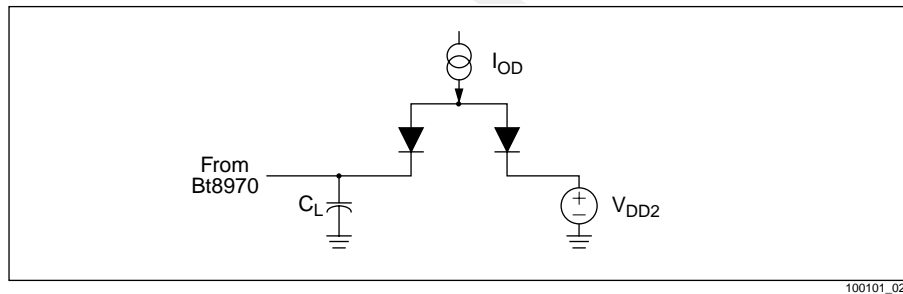

Figure 5-16. Open-Drain Output Load ( $\overline{IRQ}$ )



## 5.7 Timing Measurements

Figure 5-17 illustrates input waveforms. Output waveforms are displayed in Figures 5-18 and 5-19.

Figure 5-17. Input Waveforms for Timing Tests

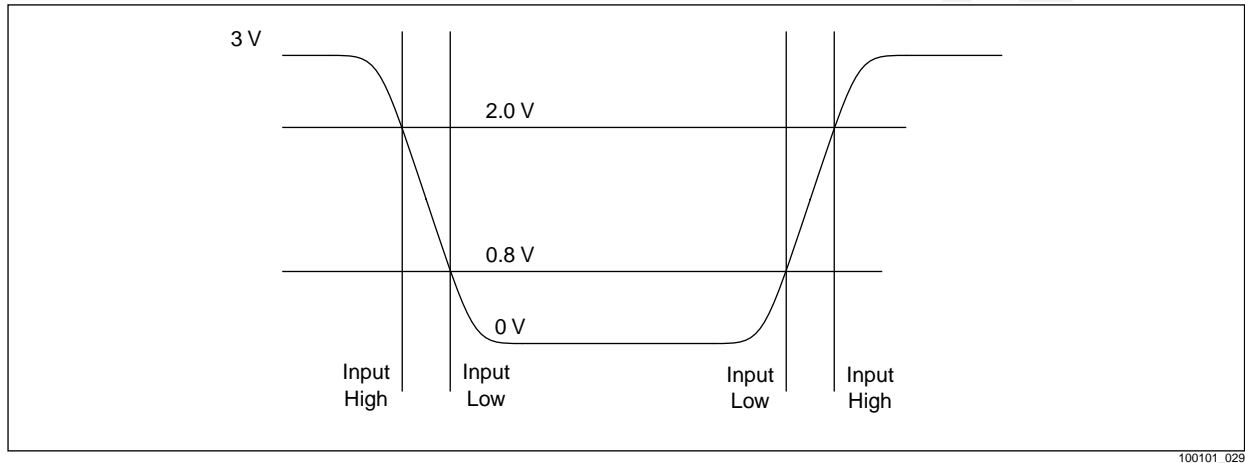

Figure 5-18. Output Waveforms for Timing Tests

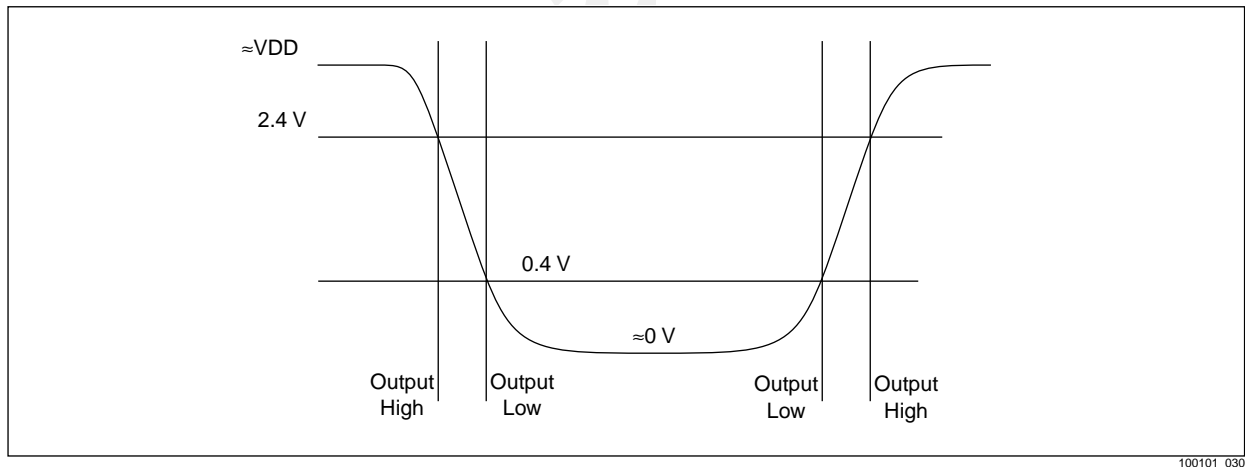
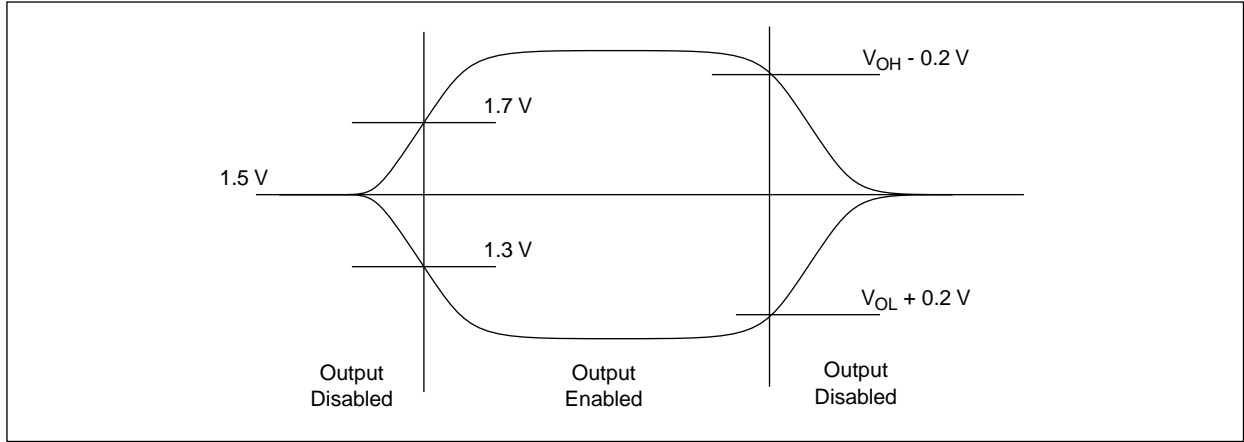

Figure 5-19. Output Waveforms for Three-state Enable and Disable Tests



Preliminary Review

11/29/00 10:00 A.M.

### 5.8 Mechanical Specifications

Figure 5-20. 100-Pin Plastic Quad Flat Pack (PQFP)

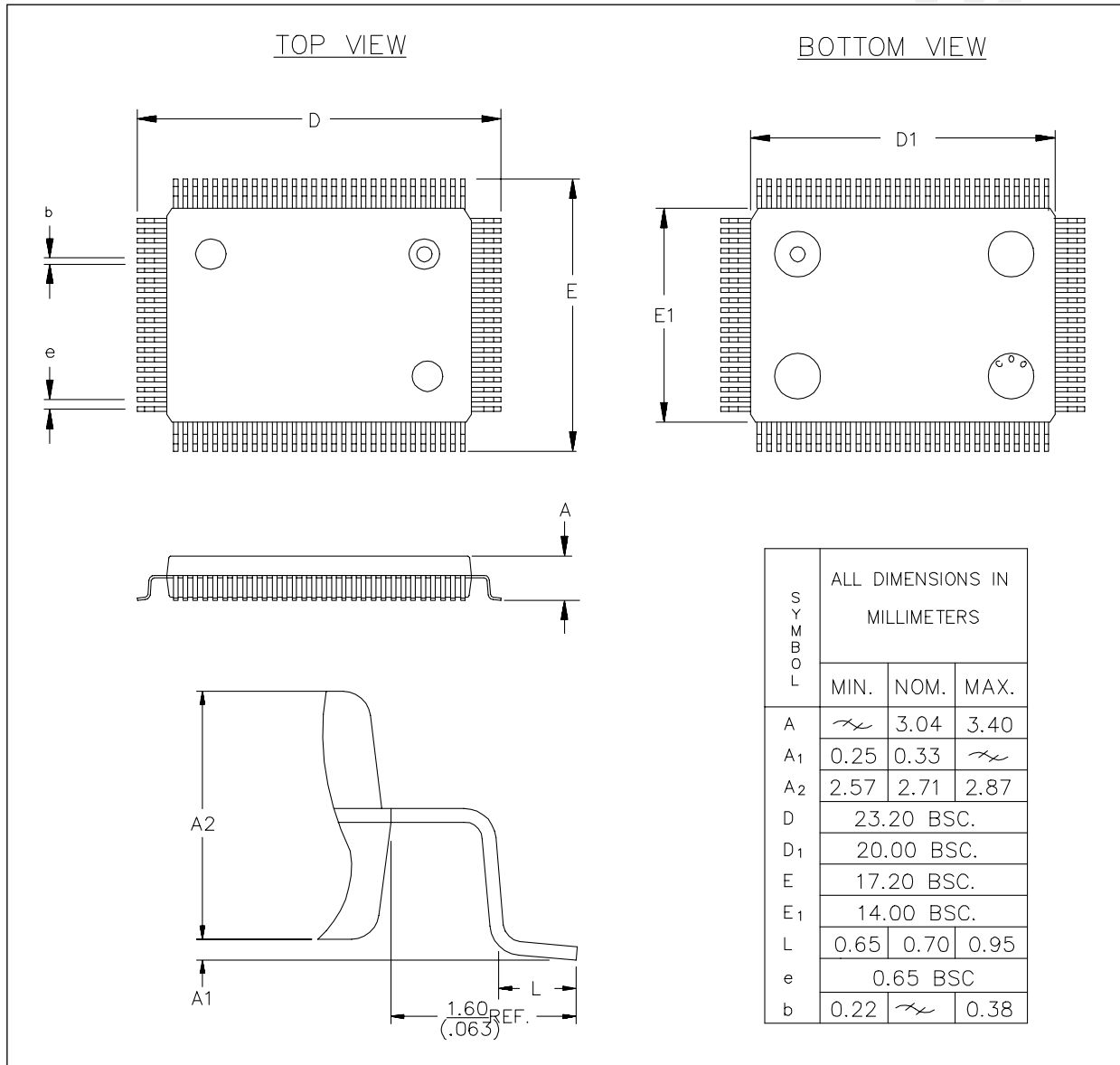

100101\_032

11/29/00 10:00 A.M.

Preliminary Review

11/29/00 10:00 A.M.

**Further Information**

literature@conexant.com  
(800) 854-8099 (North America)  
(949) 483-6996 (International)  
Printed in USA

**World Headquarters**

Conexant Systems, Inc.  
4311 Jamboree Road  
Newport Beach, CA  
92660-3007  
Phone: (949) 483-4600  
Fax 1: (949) 483-4078  
Fax 2: (949) 483-4391

**Americas****U.S. Northwest/  
Pacific Northwest – Santa Clara**

Phone: (408) 249-9696  
Fax: (408) 249-7113

**U.S. Southwest – Los Angeles**

Phone: (805) 376-0559  
Fax: (805) 376-8180

**U.S. Southwest – Orange County**

Phone: (949) 483-9119  
Fax: (949) 483-9090

**U.S. Southwest – San Diego**

Phone: (858) 713-3374  
Fax: (858) 713-4001

**U.S. North Central – Illinois**

Phone: (630) 773-3454  
Fax: (630) 773-3907

**U.S. South Central – Texas**

Phone: (972) 733-0723  
Fax: (972) 407-0639

**U.S. Northeast – Massachusetts**

Phone: (978) 367-3200  
Fax: (978) 256-6868

**U.S. Southeast – North Carolina**

Phone: (919) 858-9110  
Fax: (919) 858-8669

**U.S. Southeast – Florida/  
South America**

Phone: (727) 799-8406  
Fax: (727) 799-8306

**U.S. Mid-Atlantic – Pennsylvania**

Phone: (215) 244-6784  
Fax: (215) 244-9292

**Canada – Ontario**

Phone: (613) 271-2358  
Fax: (613) 271-2359

**Europe****Europe Central – Germany**

Phone: +49 89 829-1320  
Fax: +49 89 834-2734

**Europe North – England**

Phone: +44 1344 486444  
Fax: +44 1344 486555

**Europe – Israel/Greece**

Phone: +972 9 9524000  
Fax: +972 9 9573732

**Europe South – France**

Phone: +33 1 41 44 36 51  
Fax: +33 1 41 44 36 90

**Europe Mediterranean – Italy**

Phone: +39 02 93179911  
Fax: +39 02 93179913

**Europe – Sweden**

Phone: +46 (0) 8 5091 4319  
Fax: +46 (0) 8 590 041 10

**Europe – Finland**

Phone: +358 (0) 9 85 666 435  
Fax: +358 (0) 9 85 666 220

**Asia – Pacific****Taiwan**

Phone: (886-2) 2-720-0282  
Fax: (886-2) 2-757-6760

**Australia**

Phone: (61-2) 9869 4088  
Fax: (61-2) 9869 4077

**China – Central**

Phone: 86-21-6361-2515  
Fax: 86-21-6361-2516

**China – South**

Phone: (852) 2 827-0181  
Fax: (852) 2 827-6488

**China – South (Satellite)**

Phone: (86) 755-5182495

**China – North**

Phone: (86-10) 8529-9777  
Fax: (86-10) 8529-9778

**India**

Phone: (91-11) 692-4789  
Fax: (91-11) 692-4712

**Korea**

Phone: (82-2) 565-2880  
Fax: (82-2) 565-1440

**Korea (Satellite)**

Phone: (82-53) 745-2880  
Fax: (82-53) 745-1440

**Singapore**

Phone: (65) 737 7355  
Fax: (65) 737 9077

**Japan**

Phone: (81-3) 5371 1520  
Fax: (81-3) 5371 1501