

Features

- Dual ADC with 8-bit Resolution
- 500 Msps Sampling Rate per Channel, 1 Gsps in Interlaced Mode
- Single or 1:2 Demultiplexed Output
- LVDS Output Format (100 Ω)
- 500 mVpp Analog Input (Differential Only)
- Differential or Single-ended 50 Ω PECL/LVDS Compatible Clock Inputs
- Power Supply: 3.3V (Analog), 3.3V (Digital), 2.25V (Output)
- LQFP144 Package
- Temperature Range:
 - 0°C < T_A < 70°C (Commercial Grade)
 - -40°C < T_A < 85°C (Industrial Grade)
- 3-wire Serial Interface
 - 16-bit Data, 3-bit Address
 - 1:2 or 1:1 Output Demultiplexer Ratio Selection
 - Full or Partial Standby Mode
 - Analog Gain (± 1.5 dB) Digital Control
 - Input Clock Selection
 - Analog Input Switch Selection
 - Binary or Gray Logical Outputs
 - Synchronous Data Ready Reset
 - Data Ready Delay Adjustable on Both Channels
 - Interlacing Functions:
 - Offset and Gain (Channel to Channel) Calibration
 - Digital Fine SDA (Fine Sampling Delay Adjust) on One Channel
 - Internal Static or Dynamic Built-In Test (BIT)

Performance

- Low Power Consumption: 0.7W per Channel
- Power Consumption in Standby Mode: 120 mW
- 1 GHz Full Power Input Bandwidth (-3 dB)
- SNR = 43 dB Typ (7.0 ENOB), THD = -53 dBc, SFDR = -55 dBc at F_s = 500 Msps
F_{in} = 250 MHz
- 2-tone IMD3: -54 dBc (249 MHz, 251 MHz) at 500 Msps
- DNL = 0.25 LSB, INL = 0.5 LSB
- Channel to Channel Input Offset Error: 0.5 LSB Max (After Calibration)
- Gain Matching (Channel to Channel): 0.5 LSB Max (After Calibration)
- Low Bit Error Rate (10⁻¹⁵) at 500 Msps

Application

- Instrumentation
- Satellite Receivers
- Direct RF Down Conversion
- WLAN



**Dual 8-bit
500 Msps ADC**

**AT84AD004
Smart ADC**





Description

The AT84AD004 is a monolithic dual 8-bit analog-to-digital converter, offering low 1.4W power consumption and excellent digitizing accuracy. It integrates dual on-chip track/holds that provide an enhanced dynamic performance with a sampling rate of up to 500 Msps and an input frequency bandwidth of 1 GHz. The dual concept, the integrated demultiplexer and the easy interleaving mode make this device user-friendly for all dual channel applications, such as direct RF conversion or data acquisition. The *smart* function of the 3-wire serial interface eliminates the need for external components, which are usually necessary for gain and offset tuning and setting of other parameters, leading to space and power reduction as well as system flexibility.

Functional Description

The AT84AD004 is a dual 8-bit 500 Msps ADC based on advanced high-speed BiCMOS technology.

Each ADC includes a front-end analog multiplexer followed by a Sample and Hold (S/H), and an 8-bit flash-like architecture core analog-to-digital converter. The output data is followed by a switchable 1:1 or 1:2 demultiplexer and LVDS output buffers (100Ω).

Two over-range bits are provided for adjustment of the external gain control on each channel.

A 3-wire serial interface (3-bit address and 16-bit data) is included to provide several adjustments:

- Analog input range adjustment (± 1.5 dB) with 8-bit data control using a 3-wire bus interface (steps of 0.18 dB)
- Analog input switch: both ADCs can convert the same analog input signal I or Q
- Gray or binary encoder output. Output format: DMUX 1:1 or 1:2 with control of the output frequency on the data ready output signal
- Partial or full standby on channel I or channel Q
- Clock selection:
 - Two independent clocks: CLKI and CLKQ
 - One master clock (CLKI) with the same phase for channel I and channel Q
 - One master clock but with two phases (CLKI for channel I and CLKIB for channel Q)
- ISA: Internal Settling Adjustment on channel I and channel Q
- FiSDA: Fine Sampling Delay Adjustment on channel Q
- Adjustable Data Ready Output Delay on both channels
- Test mode: decimation mode (by 16), Built-in Test

A calibration phase is provided to set the two DC offsets of channel I and channel Q close to code 127.5 and calibrate the two gains to achieve a maximum difference of 0.5 LSB. The offset and gain error can also be set externally via the 3-wire serial interface.

The AT84AD004 operates in fully differential mode from the analog inputs up to the digital outputs. The AT84AD004 features a full-power input bandwidth of 1 GHz.

Figure 1. Simplified Block Diagram

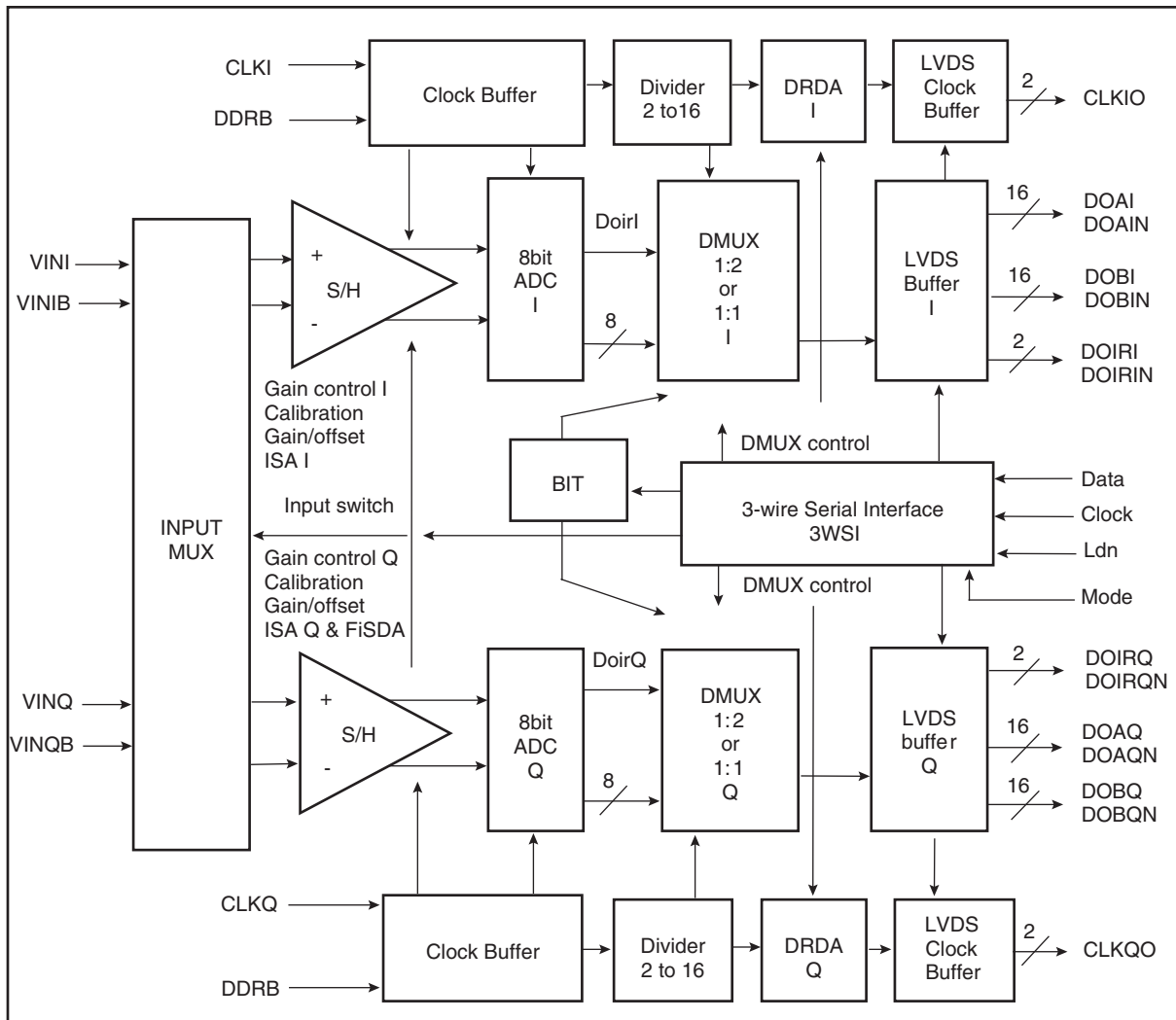

Typical Applications

Figure 2. Satellite Receiver Application

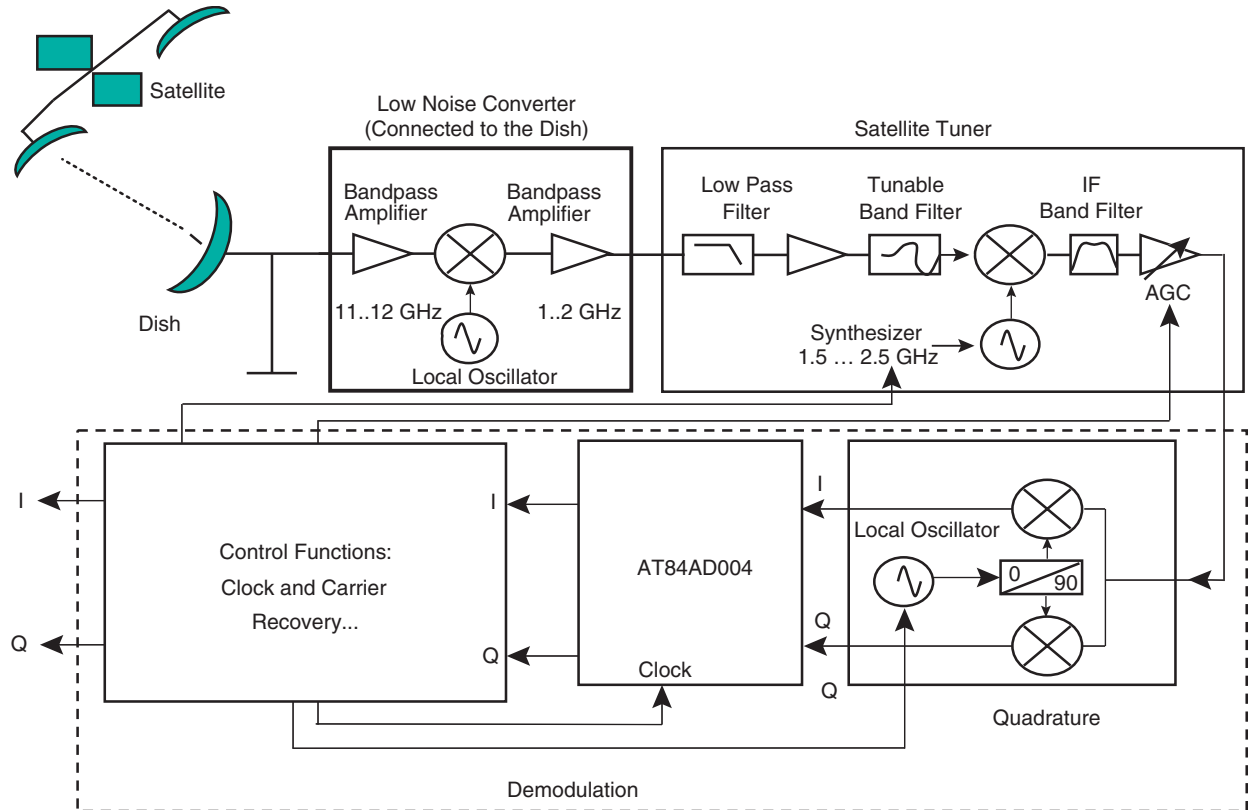
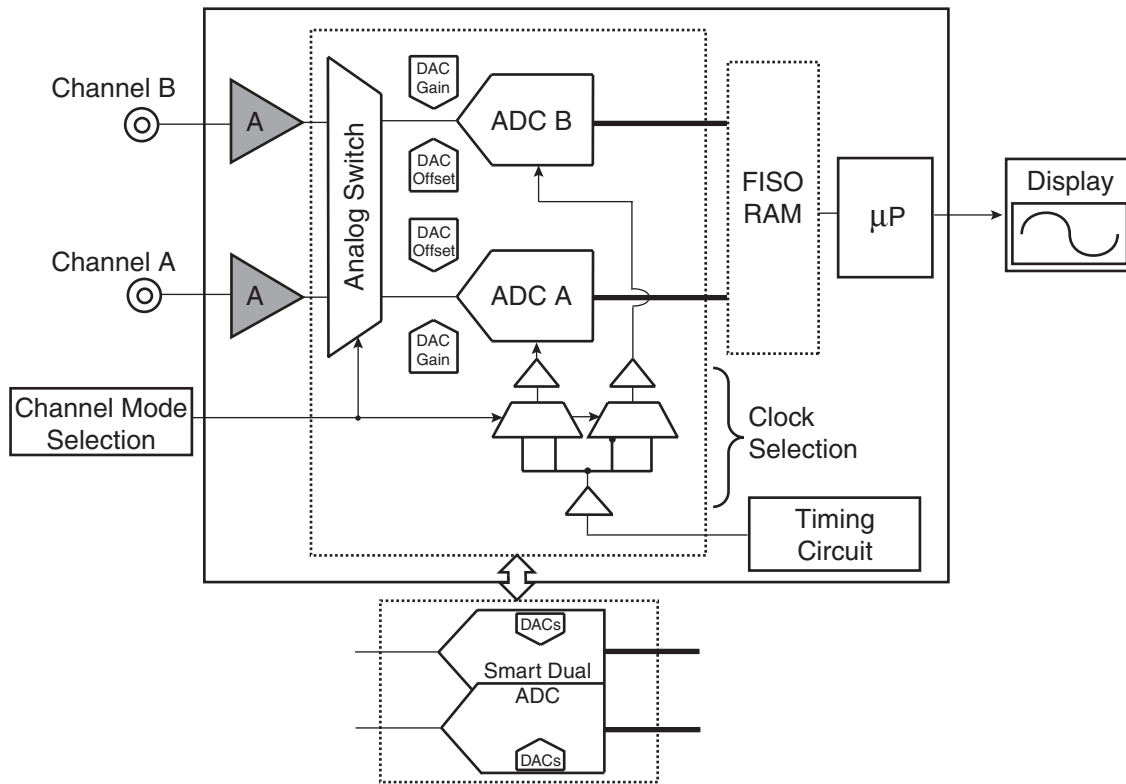

Figure 3. Dual Channel Digital Oscilloscope Application



Absolute Maximum Ratings

Parameter	Symbol	Value	Unit
Analog positive supply voltage	V_{CCA}	3.6	V
Digital positive supply voltage	V_{CCD}	3.6	V
Output supply voltage	V_{CCO}	3.6	V
Maximum difference between V_{CCA} and V_{CCD}	V_{CCA} to V_{CCD}	± 0.8	V
Minimum V_{CCO}	V_{CCO}	1.6	V
Analog input voltage	V_{INI} or V_{INIB} V_{INQ} or V_{INQB}	1/-1	V
Digital input voltage	V_D	-0.3 to $V_{CCD} + 0.3$	V
Clock input voltage	V_{CLK} or V_{CLKB}	-0.3 to $V_{CCD} + 0.3$	V
Maximum difference between V_{CLK} and V_{CLKB}	$V_{CLK} - V_{CLKB}$	-2 to 2	V
Maximum junction temperature	T_J	125	$^{\circ}\text{C}$
Storage temperature	T_{stg}	-65 to 150	$^{\circ}\text{C}$
Lead temperature (soldering 10s)	T_{leads}	300	$^{\circ}\text{C}$

Note: Absolute maximum ratings are limiting values (referenced to GND = 0V), to be applied individually, while other parameters are within specified operating conditions. Long exposure to maximum ratings may affect device reliability.

Recommended Conditions of Use

Parameter	Symbol	Comments	Recommended Value	Unit
Analog supply voltage	V_{CCA}		3.3	V
Digital supply voltage	V_{CCD}		3.3	V
Output supply voltage	V_{CCO}		2.25	V
Differential analog input voltage (full-scale)	$V_{INI} - V_{INIB}$ or $V_{INQ} - V_{INQB}$		500	mVpp
Differential clock input level	V_{inclk}		600	mVpp
Internal Settling Adjustment (ISA) with a 3-wire serial interface for channel I and channel Q	ISA		-50	ps
Operating temperature range	$T_{Ambient}$	Commercial grade Industrial grade	$0 < T_A < 70$ $-40 < T_A < 85$	°C

Electrical Operating Characteristics

Unless otherwise specified:

- $V_{CCA} = 3.3V$; $V_{CCD} = 3.3V$; $V_{CCO} = 2.25V$
- $V_{INI} - V_{INIB}$ or $V_{INQ} - V_{INQB} = 500$ mVpp full-scale differential input
- LVDS digital outputs (100Ω)
- T_A (typical) = $25^\circ C$
- Full temperature range: $0^\circ C < T_A < 70^\circ C$ (commercial grade) or $-40^\circ C < T_A < 85^\circ C$ (industrial grade)

Table 1. Electrical Operating Characteristics in Nominal Conditions

Parameter	Symbol	Min	Typ	Max	Unit
Resolution			8		Bits
Power Requirements					
Positive supply voltage					
- Analog	V_{CCA}	3.15	3.3	3.45	V
- Digital	V_{CCD}	3.15	3.3	3.45	V
Output digital (LVDS) and serial interface	V_{CCO}	2.0	2.25	2.5	V
Supply current (typical conditions)					
- Analog	I_{CCA}		150	180	mA
- Digital	I_{CCD}		230	275	mA
- Output	I_{CCO}		100	120	mA
Supply current (1:2 DMUX mode)					
- Analog	I_{CCA}		150	180	mA
- Digital	I_{CCD}		260	310	mA
- Output	I_{CCO}		175	210	mA

Table 1. Electrical Operating Characteristics in Nominal Conditions (Continued)

Parameter	Symbol	Min	Typ	Max	Unit
Supply current (2 input clocks, 1:2 DMUX mode) - Analog - Digital - Output	I_{CCA} I_{CCD} I_{CCO}		150 290 180	180 350 215	mA
Supply current (1 channel only, 1:1 DMUX mode) - Analog - Digital - Output	I_{CCA} I_{CCD} I_{CCO}		80 160 55	95 190 65	mA mA mA
Supply current (1 channel only, 1:2 DMUX mode) - Analog - Digital - Output	I_{CCA} I_{CCD} I_{CCO}		80 170 90	95 205 110	mA mA mA
Supply current (full standby mode) - Analog - Digital - Output	I_{CCA} I_{CCD} I_{CCO}		12 24 3	17 34 5	mA mA mA
Nominal dissipation (1 clock, 1:1 DMUX mode, 2 channels)	P_D		1.4	1.7	W
Nominal dissipation (full standby mode)	stbpd		120		mW
Analog Inputs					
Full-scale differential analog input voltage	$V_{INi} - V_{INiB}$ or $V_{INQ} - V_{INQB}$	450	500	550	mV mV
Analog input capacitance I and Q	C_{IN}			2	pF
Full power input bandwidth (-3 dB)	FPBW		1.0		GHz
Gain flatness (-0.5 dB)			400		MHz
Clock Input					
Logic compatibility for clock inputs and DDRB Reset (pins 124, 125, 126, 127, 128, 129)		PECL/ECL/LVDS			
PECL/LVDS clock inputs voltages ($V_{CLKI/IN}$ or $V_{CLKQ/QN}$) Differential logical level	$V_{IL} - V_{IH}$		600		mV
Clock input power level		-9	0	6	dBm
Clock input capacitance			2		pF
Digital Outputs					
Logic compatibility for digital outputs (depending on the value of V_{CCO})		LVDS			
Differential output voltage swings (assuming $V_{CCO} = 2.25V$)	V_{OD}	220	270	350	mV

Table 1. Electrical Operating Characteristics in Nominal Conditions (Continued)

Parameter	Symbol	Min	Typ	Max	Unit
Output levels (assuming $V_{CCO} = 2.25V$) 100 Ω differentially terminated					
Logic 0 voltage	V_{OL}	1.0	1.1	1.2	V
Logic 1 voltage	V_{OH}	1.25	1.35	1.45	V
Output offset voltage (assuming $V_{CCO} = 2.25V$) 100 Ω differentially terminated	V_{OS}	1125	1250	1325	mV
Output impedance	R_O		50		Ω
Output current (shorted output)				12	mA
Output current (grounded output)			30		mA
Output level drift with temperature			1.3		mV/ $^{\circ}C$
Digital Input (Serial Interface)					
Maximum clock frequency (input clk)	Fclk			50	MHz
Input logical level 0 (clk, mode, data, ldn)		-0.4	0	0.4	V
Input logical level 1 (clk, mode, data, ldn)		$V_{CCO} - 0.4$	$V_{CCO} - 0.4$	$V_{CCO} + 0.4$	V
Output logical level 0 (cal)		-0.4	0	0.4	V
Output logical level 1 (cal)		$V_{CCO} - 0.4$	V_{CCO}	$V_{CCO} + 0.4$	V
Maximum output load (cal)				15	pF

Note: The gain setting is 0 dB, one clock input, no standby mode [full power mode], 1:1 DMUX, calibration off.

Table 2. Electrical Operating Characteristics

Parameter	Symbol	Min	Typ	Max	Unit
DC Accuracy					
No missing code		Guaranteed over specified temperature range			
Differential non-linearity	DNL		0.25	0.6	LSB
Integral non-linearity	INL		0.5	1	LSB
Gain error (single channel I or Q) with calibration		-0.5	0	0.5	LSB
Input offset matching (single channel I or Q) with calibration		-0.5	0	0.5	LSB
Gain error drift against temperature			0.062		LSB/ $^{\circ}C$
Gain error drift against V_{CCA}			0.064		LSB/mV
Mean output offset code with calibration		127	127.5	128	LSB
Transient Performance					
Bit Error Rate Fs = 1 Gsps Fin = 250 MHz	BER		10^{-15}	10^{-12}	Error/sample
ADC settling time channel I or Q (between 10% - 90% of output response) $V_{ini} - V_{iniB} = 500$ mVpp	TS		170		ps

Note: The gain setting is 0 dB, two clock inputs, no standby mode [full power mode], 1:2 DMUX, calibration on.

Table 3. AC Performances

Parameter	Symbol	Min	Typ	Max	Unit
AC Performance					
Signal-to-noise Ratio					
Fs = 500 Msps Fin = 20 MHz	SNR	42	44		dBc
Fs = 500 Msps Fin = 250 MHz		41	43		dBc
Fs = 500 Msps Fin = 500 MHz			42		dBc
Effective Number of Bits					
Fs = 500 Msps Fin = 20 MHz	ENOB	7	7.2		Bits
Fs = 500 Msps Fin = 250 MHz		6.7	7.0		Bits
Fs = 500 Msps Fin = 500 MHz			6.8		Bits
Total Harmonic Distortion (First 9 Harmonics)					
Fs = 500 Msps Fin = 20 MHz	THD	48	54		dBc
Fs = 500 Msps Fin = 250 MHz		47	53		dBc
Fs = 500 Msps Fin = 500 MHz			51		dBc
Spurious Free Dynamic Range					
Fs = 500 Msps Fin = 20 MHz	ISFDRI	50	56		dBc
Fs = 500 Msps Fin = 250 MHz		49	55		dBc
Fs = 500 Msps Fin = 500 MHz			54		dBc
Two-tone Inter-modulation Distortion (Single Channel)					
$F_{IN1} = 249 \text{ MHz}$, $F_{IN2} = 251 \text{ MHz}$ at $F_s = 500 \text{ Msps}$	IMD		-54		dBc
Phase matching using auto-calibration and FiSDA in interlace mode (channel I and Q) Fin = 250 MHz Fs = 500 Msps	$d\phi$	-0.7	0	0.7	°
Crosstalk channel I versus channel Q Fin = 250 MHz, $F_s = 500 \text{ Msps}^{(2)}$	Cr		-55		dB

- Notes: 1. Differential input [-1 dBFS analog input level], gain setting is 0 dB, two input clock signals, no standby mode, 1:1 DMUX, ISA = -50 ps.
2. Measured on the AT84AD004TD-EB Evaluation Board.

Table 4. AC Performances in Interlace Mode

Parameter	Symbol	Min	Typ	Max	Unit
Interlace Mode					
Maximum equivalent clock frequency $F_{int} = 2 \times F_s$ Where F_s = external clock frequency	F_{int}	1			Gsps
Minimum clock frequency	F_{int}		20		Msps
Differential non-linearity in interlace mode	intDNL		0.25		LSB
Integral non-linearity in interlace mode	intINL		0.5		LSB
Signal-to-noise Ratio in Interlace Mode					
$F_{int} = 1$ Gsps $F_{in} = 20$ MHz	iSNR		42		dBc
$F_{int} = 1$ Gsps $F_{in} = 250$ MHz			40		dBc
Effective Number of Bits in Interlace Mode					
$F_{int} = 1$ Gsps $F_{in} = 20$ MHz	iENOB		7.1		Bits
$F_{int} = 1$ Gsps $F_{in} = 250$ MHz			6.8		Bits
Total Harmonic Distortion in Interlace Mode					
$F_{int} = 1$ Gsps $F_{in} = 20$ MHz	liTHDI		52		dBc
$F_{int} = 1$ Gsps $F_{in} = 250$ MHz			49		dBc
Spurious Free Dynamic Range in Interlace Mode					
$F_{int} = 1$ Gsps $F_{in} = 20$ MHz	liSFDRl		54		dBc
$F_{int} = 1$ Gsps $F_{in} = 250$ MHz			52		dBc
Two-tone Inter-modulation Distortion (Single Channel) in Interlace Mode					
$F_{IN1} = 249$ MHz , $F_{IN2} = 251$ MHz at $F_{int} = 1$ Gsps	iIMD		-54		dBc

Note: One analog input on both cores, clock I samples the analog input on the rising and falling edges. The calibration phase is necessary. The gain setting is 0 dB, one input clock I, no standby mode, 1:1 DMUX, FiSDA adjustment.

Table 5. Switching Performances

Parameter	Symbol	Min	Typ	Max	Unit
Switching Performance and Characteristics - See "Timing Diagrams" on page 12.					
Maximum operating clock frequency	F_S	500			MspS
Minimum clock frequency (no transparent mode)	F_S		10		MspS
Minimum clock frequency (with transparent mode)			1		KspS
Minimum clock pulse width [high] (No transparent mode)	TC1	0.4	1	50	ns
Minimum clock pulse width [low] (No transparent mode)	TC2	0.4	1	50	ns
Aperture delay: nominal mode with ISA & FiSDA	TA		1		ns
Aperture uncertainty	Jitter		0.4		ps (rms)
Data output delay between input clock and data	TDO		3.8		ns
Data Ready Output Delay	TDR		3		ns
Data Ready Reset to Data Ready	TRDR		2		ns
Data Output Delay with Data Ready	TD2		$1/2 F_S + T_{drda}$		ps
Data Ready (CLKO) Delay Adjust (140 ps steps)	Tdrda range		-560 to 420		ps
Output skew		50		100	ps
Output rise/fall time for DATA (20% - 80%)	TR/TF	300	350	500	ps
Output rise/fall time for DATA READY (20% - 80%)	TR/TF	300	350	500	ps
Data pipeline delay (nominal mode)	TPD	3 (port B) 3.5 (port A, 1:1 DMUX mode) 4 (port A, 1:2 DMUX mode)			Clock cycles
Data pipeline delay (nominal mode) in S/H transparent mode		2.5 (port B) 3 (port A, 1:1 DMUX mode) 3.5 (port A, 1:2 DMUX mode)			
DDRb recommended pulse width		1			ns

Timing Diagrams

Figure 4. Timing Diagram, ADC I or ADC Q, 1:2 DMUX Mode, Clock I for ADC I, Clock Q for ADC Q

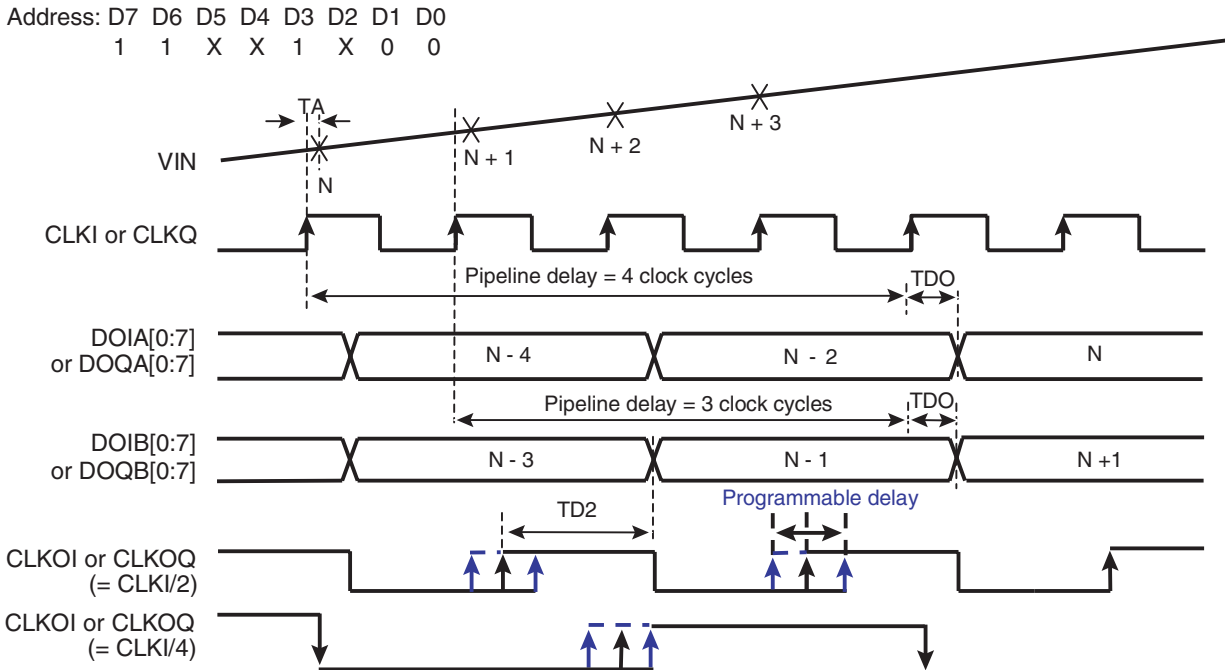
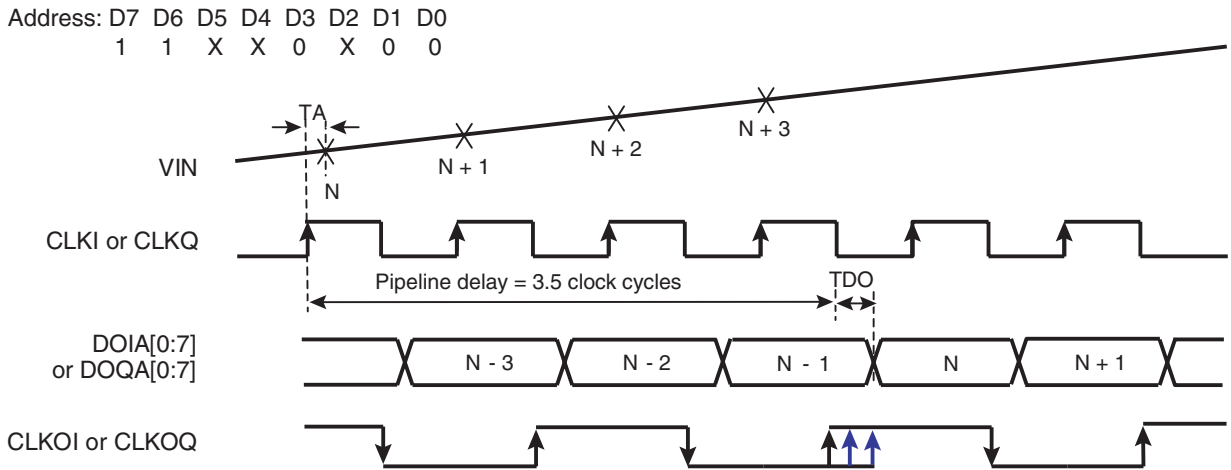

Figure 5. 1:1 DMUX Mode, Clock I = ADC I, Clock Q = ADC Q



DOIB[0:7] and DOQB[0:7] are high impedance

Figure 6. 1:2 DMUX Mode, Clock I = ADC I, Clock I = ADC Q

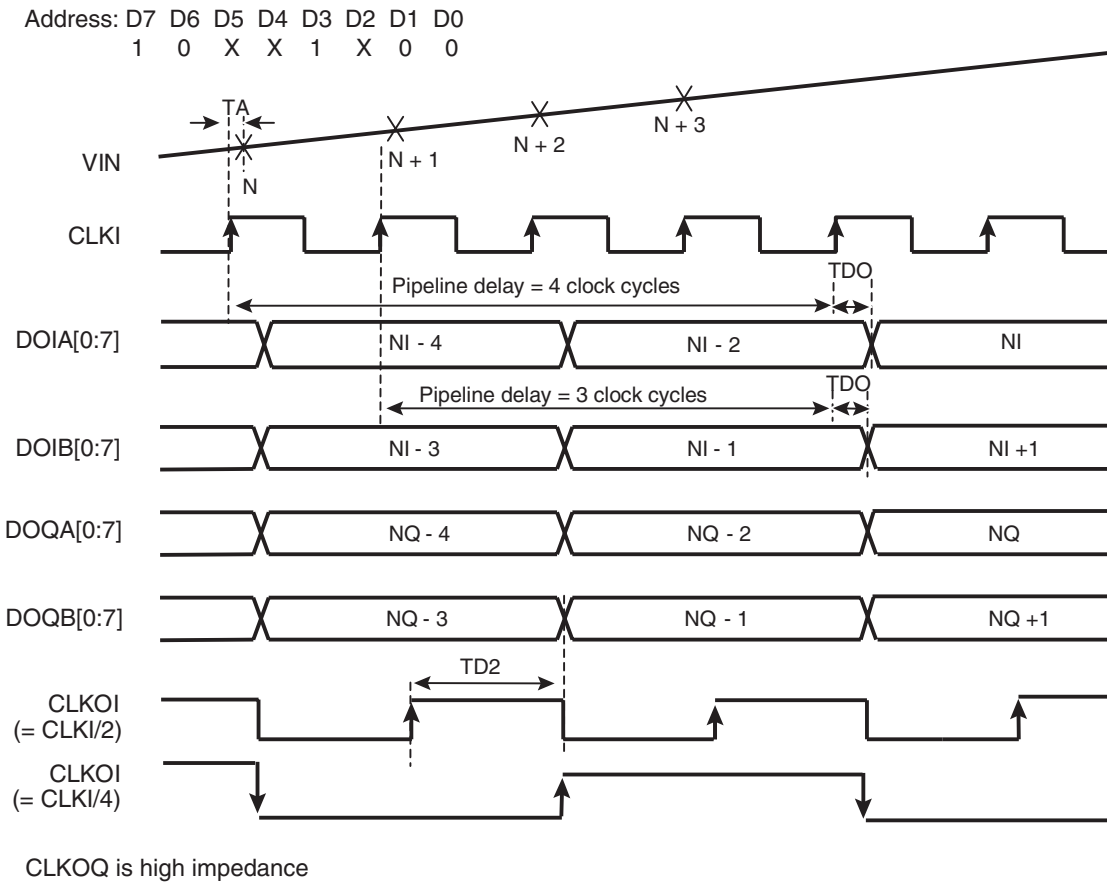
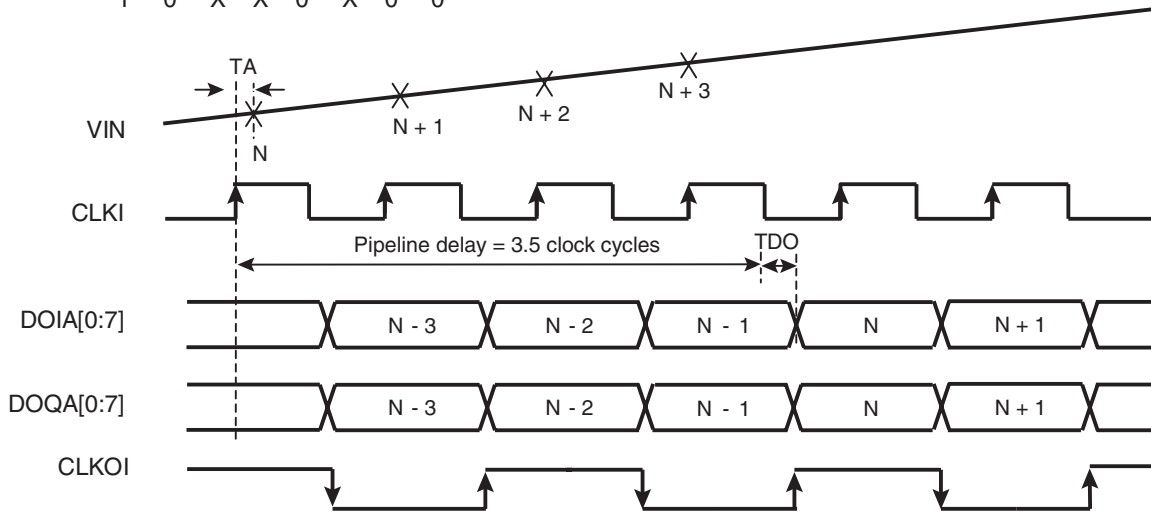

Figure 7. 1:1 DMUX Mode, Clock I = ADC I, Clock I = ADC Q

Address: D7 D6 D5 D4 D3 D2 D1 D0
 1 0 X X 0 X 0 0



DOIB[0:7] and DOQB[0:7] are high impedance
 CLKOQ is high impedance

Figure 8. 1:2 DMUX Mode, Clock I = ADC I, Clock IN = ADC Q

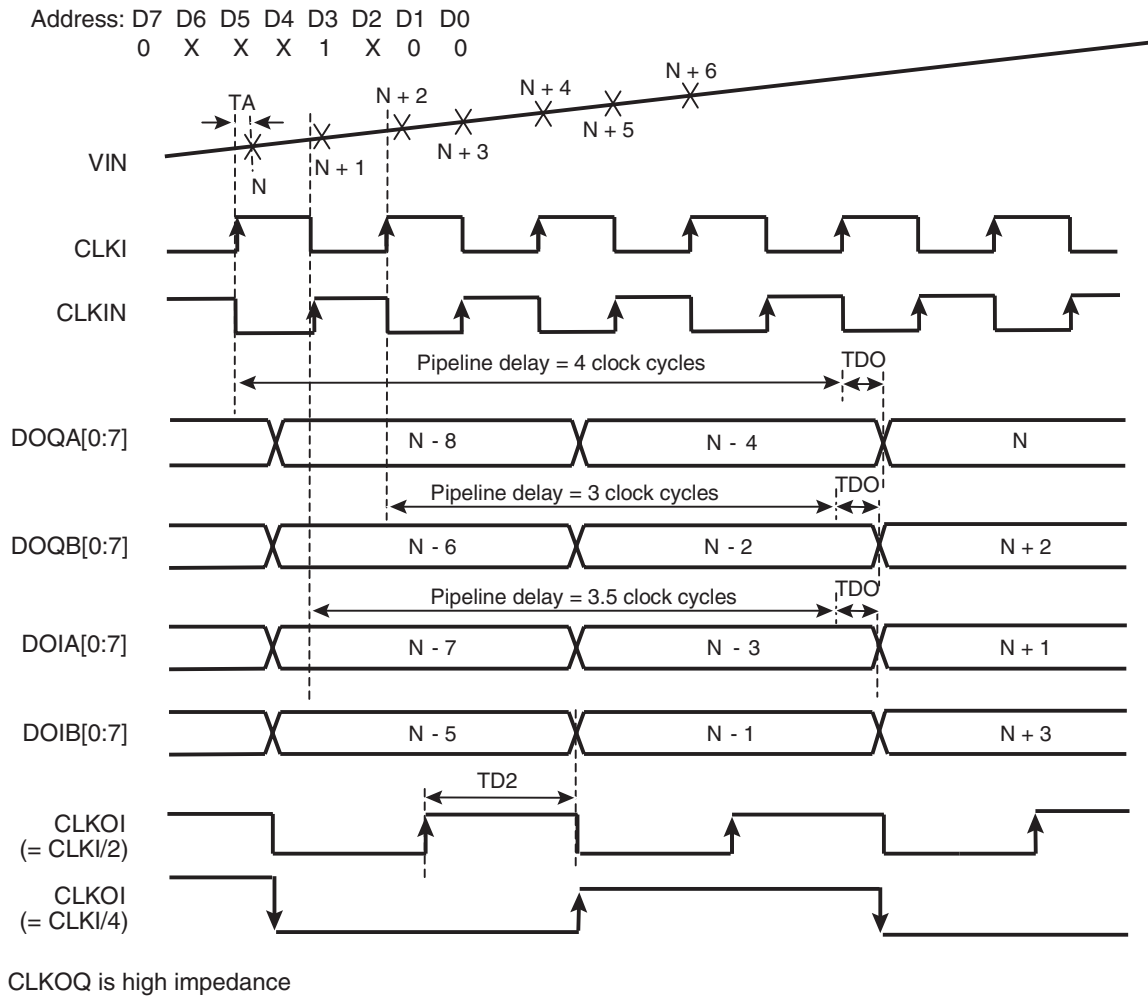

Figure 9. 1:1 DMUX Mode, Clock I = ADC I, Clock IN = ADC Q

Address: D7 D6 D5 D4 D3 D2 D1 D0
 0 X X X 0 X 0 0

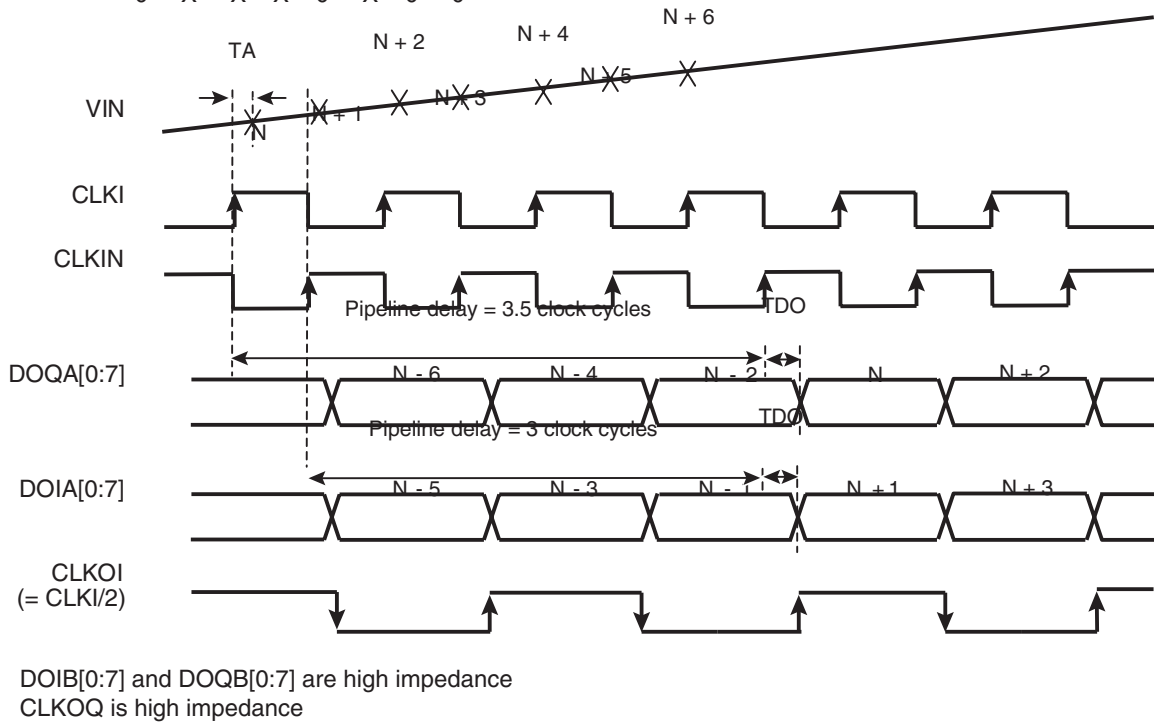
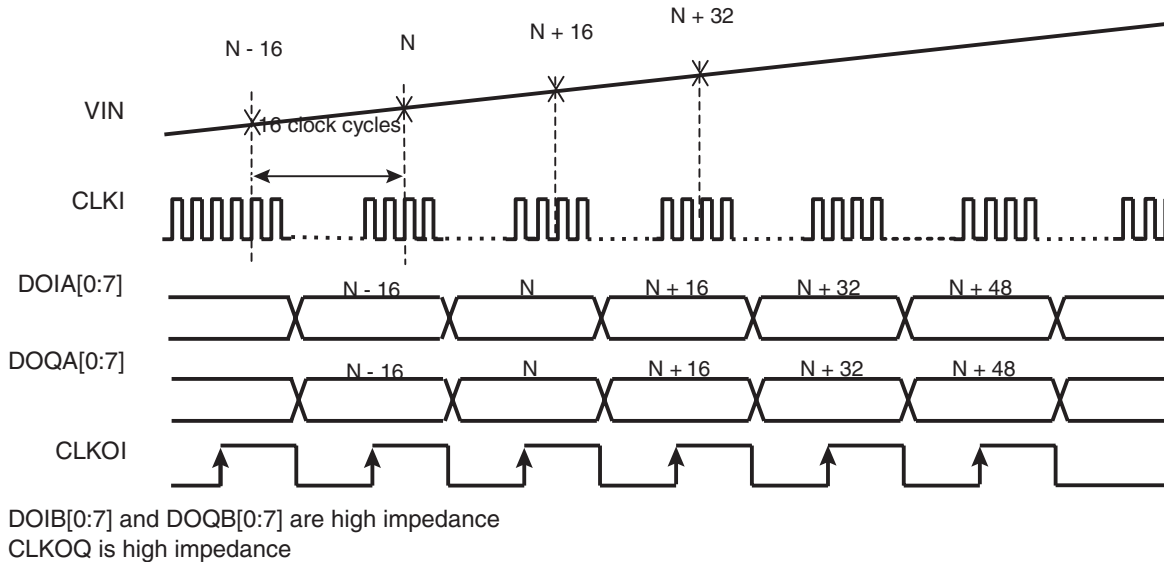

Figure 10. 1:1 DMUX Mode, Decimation Mode Test (1:16 Factor)

Address: D7 D6 D5 D4 D3 D2 D1 D0
 1 0 X X 0 X 0 0



Notes: 1. Frequency(CLKOI) = Frequency(Data) = Frequency(CLKI)/16.

Figure 11. Data Ready Reset

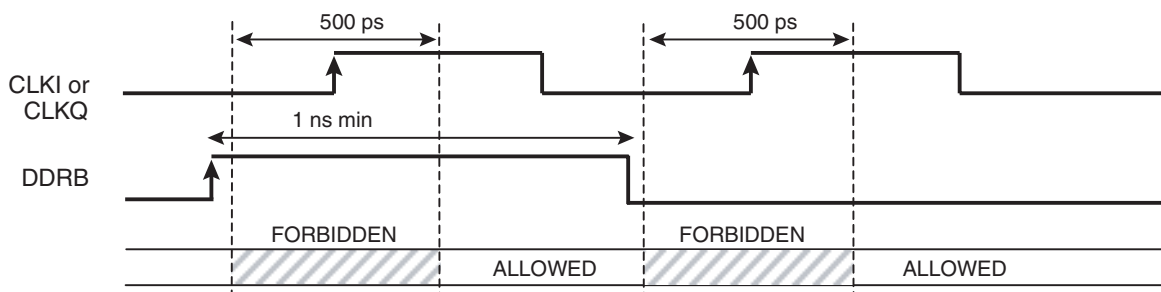
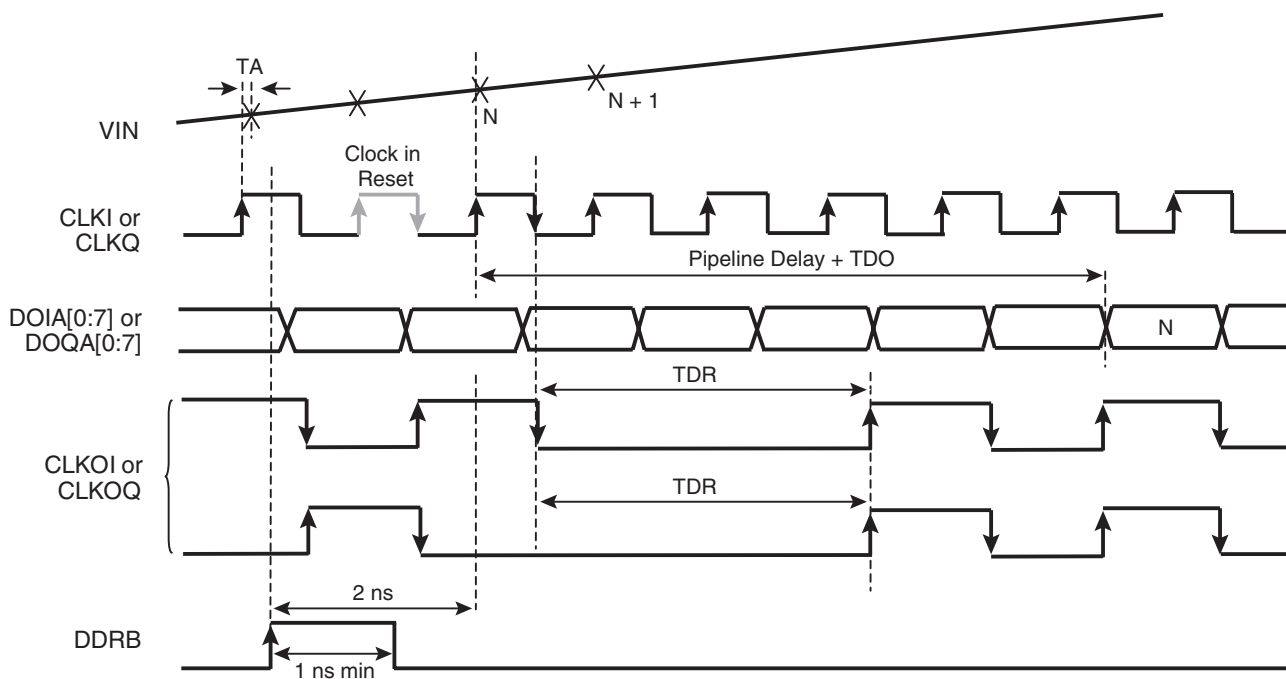
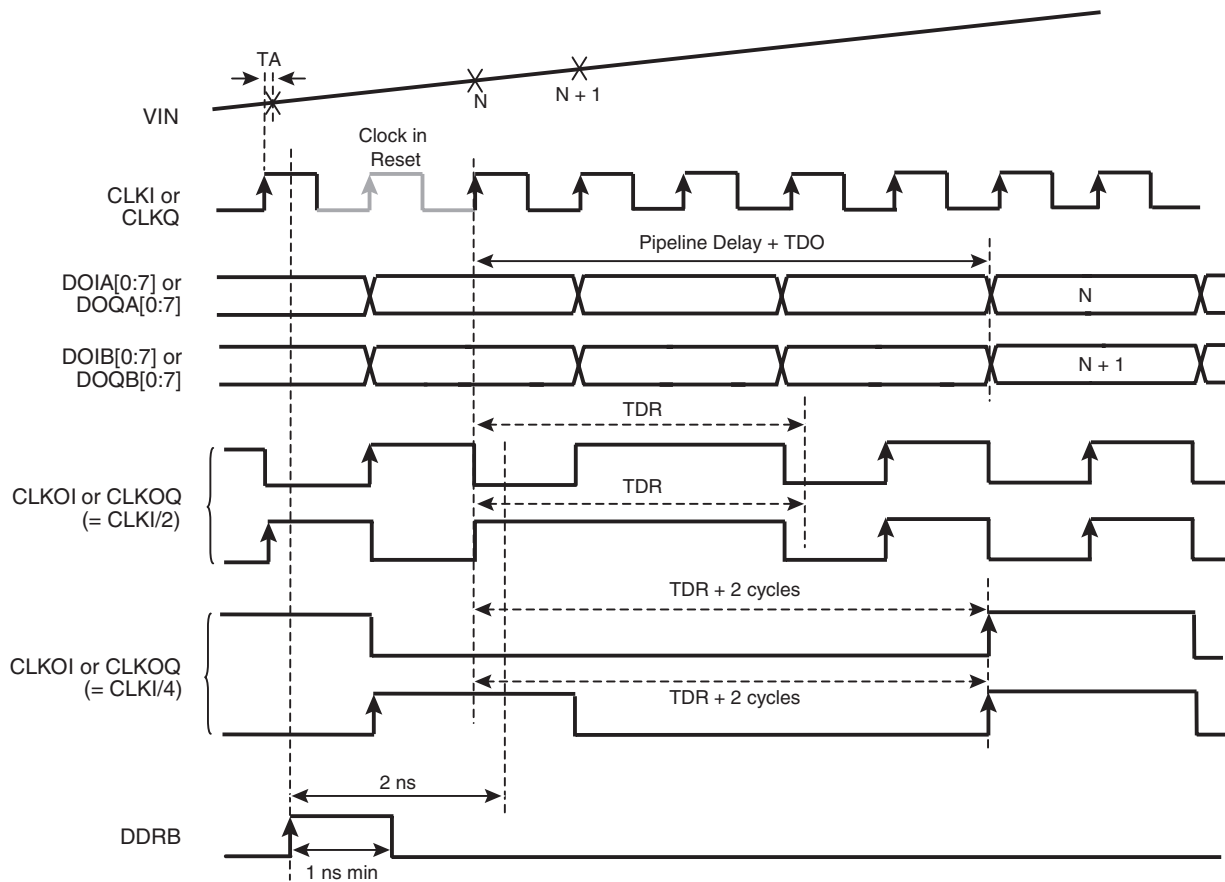

Figure 12. Data Ready Reset 1:1 DMUX Mode



Note: The Data Ready Reset is taken into account only 2 ns after it is asserted. The output clock first completes its cycle (if the reset occurs when it is high, it goes low only when its half cycle is complete; if the reset occurs when it is low, it remains low) and then only, remains in reset state (frozen to a low level in 1:1 DMUX mode). The next falling edge of the input clock after reset makes the output clock return to normal mode (after TDR).

Figure 13. Data Ready Reset 1:2 DMUX Mode



- Notes:
1. In 1:2 DMUX, Fs/2 mode:
The Data Ready Reset is taken into account only 2 ns after it is asserted. The output clock first completes its cycle (if the reset occurs when it is low, it goes high only when its half cycle is complete; if the reset occurs when it is high, it remains high) and then only, remains in reset state (frozen to a high level in 1:2 DMUX Fs/2 mode). The next rising edge of the input clock after reset makes the output clock return to normal mode (after TDR).
 2. In 1:2 DMUX, Fs/4 mode:
The Data Ready Reset is taken into account only 2 ns after it is asserted. The output clock first completes its cycle (if the reset occurs when it is high, it goes low only when its half cycle is complete; if the reset occurs when it is low, it remains low) and then only, remains in reset state (frozen to a low level in 1:2 DMUX Fs/4 mode). The next rising edge of the input clock after reset makes the output clock return to normal mode (after TDR).

Functions Description

Table 6. Description of Functions

Name	Function
V _{CCA}	Positive analog power supply
V _{CCD}	Positive digital power supply
V _{CCO}	Positive output power supply
GNDA	Analog ground
GNDD	Digital ground
GNDO	Output ground
V _{INI} , V _{INIB}	Differential analog inputs I
V _{INQ} , V _{INQB}	Differential analog inputs Q
CLKOI, CLKOIN, CLKOQ, CLKOQN	Differential output data ready I and Q
CLKI, CLKIN, CLKQ, CLKQN	Differential clock inputs I and Q
DDRB, DDRBN	Synchronous data ready reset I and Q
Mode	Bit selection for 3-wire bus or nominal setting
Clk	Input clock for 3-wire bus interface
Data	Input data for 3-wire bus
Ldn	Beginning and end of register line for 3-wire bus interface
<D0AI0:DOAI7> <D0AI0N:DOAI7N> <D0BI0:DOBI7> <D0BI0N:DOBI7N>	Differential output data port channel I
<D0AQ0:DOAQ7> <D0AQ0N:DOAQ7N> <D0BQ0:DOBQ7> <D0BQ0N:DOBQ7N>	Differential output data port channel Q
DOIRI, DOIRIN, DOIRQ, DOIRQN	Differential output IN range data I and Q
VtestQ	Test voltage output for ADC Q (to be left open)
VtestI	Test voltage output for ADC I (to be left open)
Cal	Output bit status internal calibration
Vdiode	Test diode voltage for T _j measurement

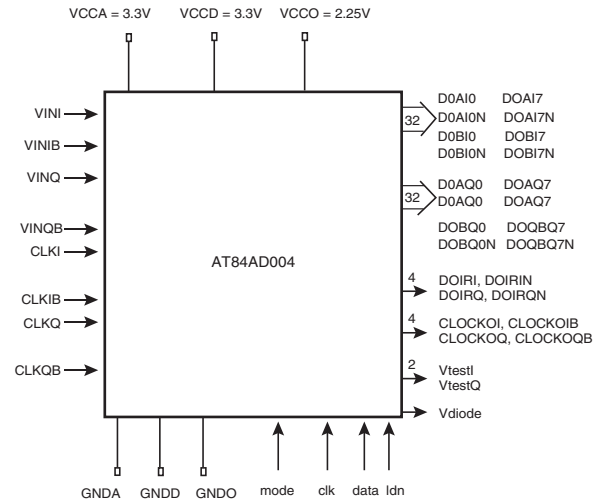

Digital Output Coding (Nominal Settings)

Table 7. Digital Output Coding (Nominal Setting)

Differential Analog Input	Voltage Level	Digital Output I or Q (Binary Coding)	Out-of-range Bit
> 250 mV	> Positive full-scale + 1/2 LSB	1 1 1 1 1 1 1 1	1
250 mV	Positive full-scale + 1/2 LSB	1 1 1 1 1 1 1 1	0
248 mV	Positive full-scale - 1/2 LSB	1 1 1 1 1 1 1 0	0
1 mV	Bipolar zero + 1/2 LSB	1 0 0 0 0 0 0 0	0
-1 mV	Bipolar zero - 1/2 LSB	0 1 1 1 1 1 1 1	0
-248 mV	Negative full-scale + 1/2 LSB	0 0 0 0 0 0 0 1	0
-250 mV	Negative full-scale - 1/2 LSB	0 0 0 0 0 0 0 0	0
< -250 mV	< Negative full-scale - 1/2 LSB	0 0 0 0 0 0 0 0	1

Pin Description

Table 8. AT84AD004 LQFP 144 Pin Description

Symbol	Pin number	Function
GNDA, GNDD, GNDO	10, 12, 22, 24, 36, 38, 40, 42, 44, 46, 51, 54, 59, 61, 63, 65, 67, 69, 85, 87, 97, 99, 109, 111, 130, 142, 144	Ground pins. To be connected to external ground plane
V _{CCA}	41, 43, 45, 60, 62, 64	Analog positive supply: 3.3V typical
V _{CCD}	9, 21, 37, 39, 66, 68, 88, 100, 112, 123, 141	3.3V digital supply
V _{CCO}	11, 23, 86, 98, 110, 143	2.25V output and 3-wire serial interface supply
V _{INI}	57, 58	In-phase (+) analog input signal of the sample & hold differential preamplifier channel I
V _{INIB}	55, 56	Inverted phase (-) of analog input signal (V _{INI})
V _{INQ}	47, 48	In-phase (+) analog input signal of the sample & hold differential preamplifier channel Q
V _{INQB}	49, 50	Inverted phase (-) of analog input signal (V _{INQ})
CLKI	124	In-phase (+) clock input signal
CLKIN	125	Inverted phase (-) clock input signal (CLKI)
CLKQ	129	In-phase (+) clock input signal

Table 8. AT84AD004 LQFP 144 Pin Description (Continued)

Symbol	Pin number	Function
CLKQN	128	Inverted phase (-) clock input signal (CLKQ)
DDRB	126	Synchronous data ready reset I and Q
DDRBN	127	Inverted phase (-) of input signal (DDRB)
DOAI0, DOAI1, DOAI2, DOAI3, DOAI4, DOAI5, DOAI6, DOAI7	117, 113, 105, 101, 93, 89, 81, 77	In-phase (+) digital outputs first phase demultiplexer (channel I) DOAI0 is the LSB. DOAI7 is the MSB
DOAI0N, DOAI1N, DOAI2N, DOAI3N, DOAI4N, DOAI5N, DOAI6N, DOAI7N,	118, 114, 106, 102, 94, 90, 82, 78	Inverted phase (-) digital outputs first phase demultiplexer (channel I) DOAI0N is the LSB. DOAI7N is the MSB
DOBI0, DOBI1, DOBI2, DOBI3, DOBI4, DOBI5, DOBI6, DOBI7	119, 115, 107, 103, 95, 91, 83, 79	In-phase (+) digital outputs second phase demultiplexer (channel I) DOBI0 is the LSB. DOBI7 is the MSB
DOBI0N, DOBI1N, DOBI2N, DOBI3N, DOBI4N, DOBI5N, DOBI6N, DOBI7N	120, 116, 108, 104, 96, 92, 84, 80	Inverted phase (-) digital outputs second phase demultiplexer (channel I) DOBI0N is the LSB. DOBI7N is the MSB
DOAQ0, DOAQ1, DOAQ2, DOAQ3, DOAQ4, DOAQ5, DOAQ6, DOAQ7	136, 140, 4, 8, 16, 20, 28, 32	In-phase (+) digital outputs first phase demultiplexer (channel Q) DOAI0 is the LSB. DOAQ7 is the MSB
DOAQ0N, DOAQ1N, DOAQ2N, DOAQ3N, DOAQ4N, DOAQ5N, DOAQ6N, DOAQ7N	135, 139, 3, 7, 15, 19, 27, 31	Inverted phase (-) digital outputs first phase demultiplexer (channel Q) DOAI0N is the LSB. DOAQ7N is the MSB
DOBQ0, DOBQ1, DOBQ2, DOBQ3, DOBQ4, DOBQ5, DOBQ6, DOBQ7	134, 138, 2, 6, 14, 18, 26, 30	In-phase (+) digital outputs second phase demultiplexer (channel Q) DOBQ0 is the LSB. DOBQ7 is the MSB
DOBQ0N, DOBQ1N, DOBQ2N, DOBQ3N, DOBQ4N, DOBQ5N, DOBQ6N, DOBQ7N	133, 137, 1, 5, 13, 17, 25, 29	Inverted phase (-) digital outputs second phase demultiplexer (channel Q) DOBQ0N is the LSB. DOBQ7N is the MSB
DOIRI	75	In-phase (+) out-of-range bit input (I phase) combined demultiplexer out-of-range is high on the leading edge of code 0 and code 256
DOIRIN	76	Inverted phase of output signal DOIRI
DOIRQ	34	In-phase (+) out-of-range bit input (Q phase) combined demultiplexer out-of-range is high on the leading edge of code 0 and code 256
DOIRQN	33	Inverted phase of output signal DOIRQ
MODE	74	Bit selection for 3-wire bus interface or nominal setting
CLK	73	Input clock for 3-wire bus interface
DATA	72	Input data for 3-wire bus
LND	71	Beginning and end of register line for 3-wire bus interface
CLKOI	121	Output clock in-phase (+) channel I

Table 8. AT84AD004 LQFP 144 Pin Description (Continued)

Symbol	Pin number	Function
CLKOIN	122	Inverted phase (-) output clock channel I
CLKOQ	132	Output clock in-phase (+) channel Q, 1/2 input clock frequency
CLKOQN	131	Inverted phase (-) output clock channel Q
VtestQ, VtestI	52, 53	Pins for internal test (to be left open)
Cal	70	Calibration output bit status
Vdiode	35	Positive node of diode used for die junction temperature measurements

Figure 14. AT84AD004 Pinout (Top View)

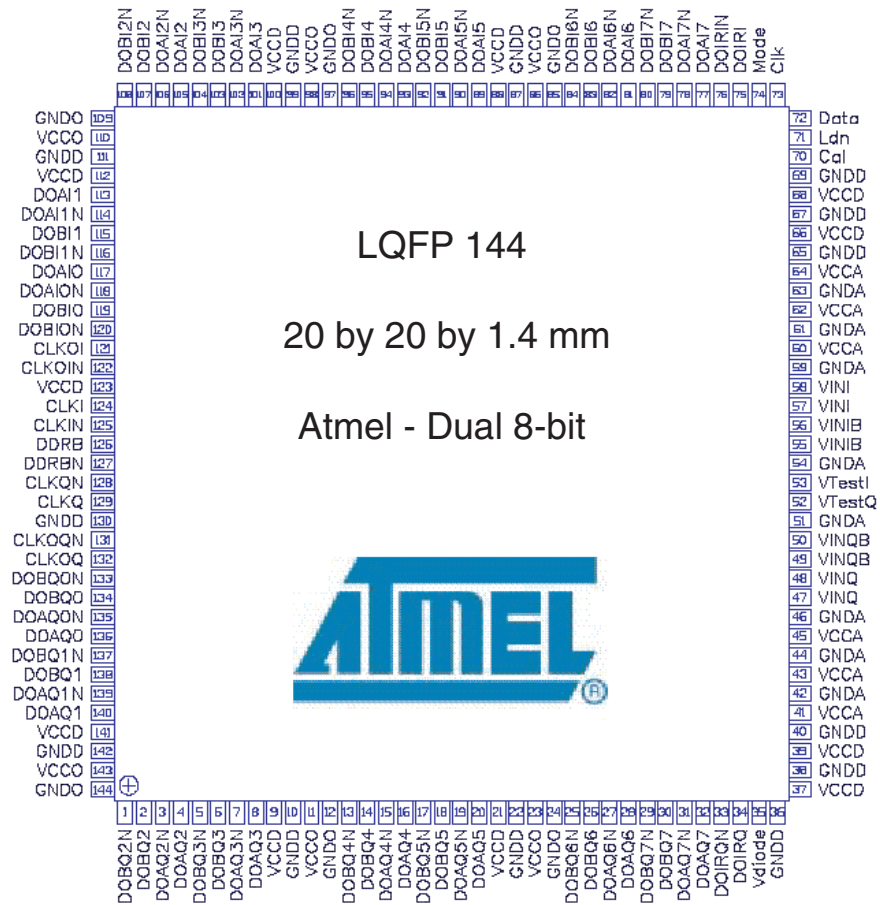

Typical Characterization Results

Nominal conditions (unless otherwise specified):

- $V_{CCA} = 3.3V$; $V_{CCD} = 3.3V$; $V_{CCO} = 2.25V$
- $V_{INI} - V_{INB}$ or V_{INQ} to $V_{INQB} = 500$ mVpp full-scale differential input
- LVDS digital outputs (100Ω)
- TA (typical) = $25^\circ C$
- Full temperature range: $0^\circ C < TA < 70^\circ C$ (commercial grade)
or $-40^\circ C < TA < 85^\circ C$ (industrial grade)

Typical Full Power Input Bandwidth

- $F_s = 500$ Msps
- $P_{clock} = 0$ dBm
- $P_{in} = -1$ dBFS
- Gain flatness (± 5 dB) from DC to > 400 MHz
- Full power input bandwidth at -3 dB > 1 GHz

Figure 15. Full Power Input Bandwidth

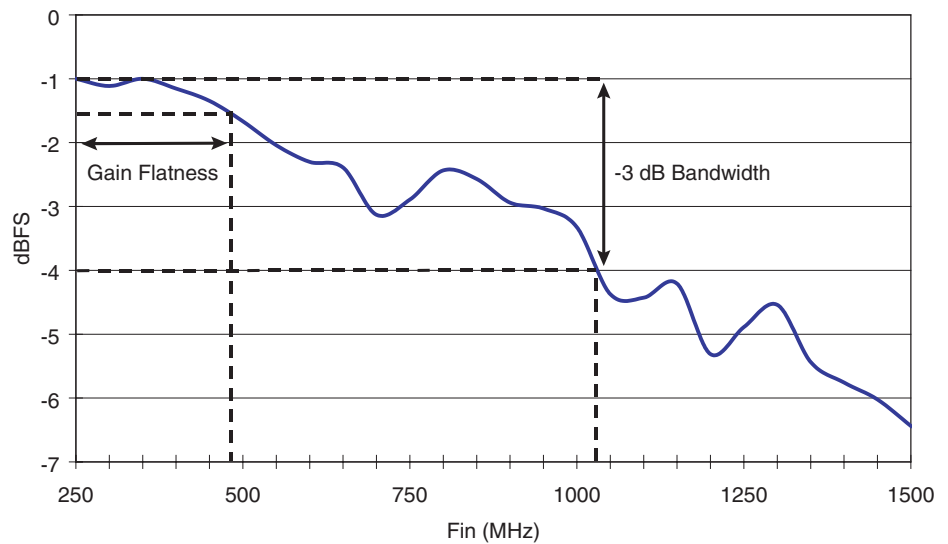

Typical Crosstalk

Figure 16. Crosstalk ($F_s = 500$ Msp/s)

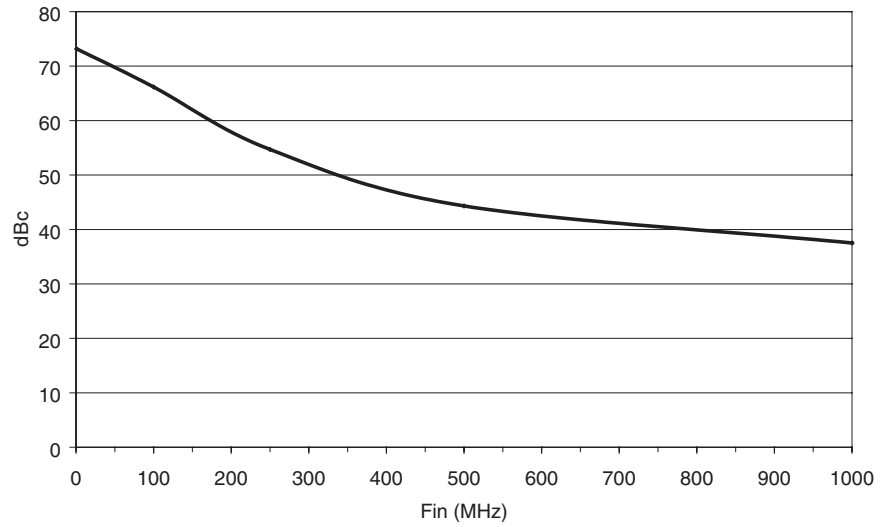

Note: Measured on the AT84AD004TD-EB Evaluation Board.

Typical DC, INL and DNL Patterns

1:2 DMUX mode, $F_s/4$ DR type

Figure 17. Typical INL ($F_s = 50$ Msp/s, $F_{in} = 1$ MHz, Saturated Input)

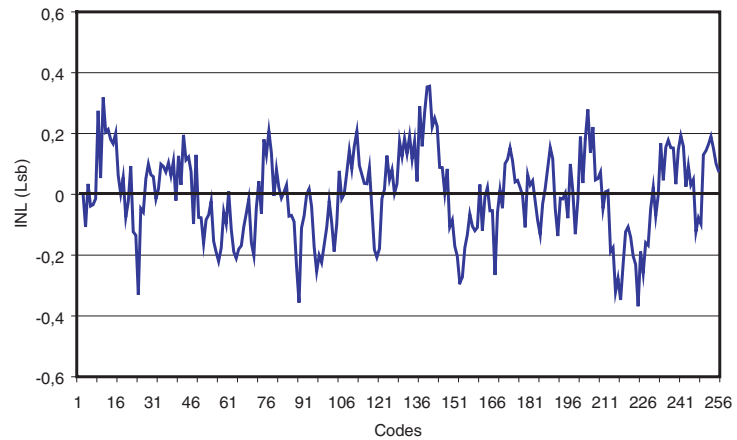
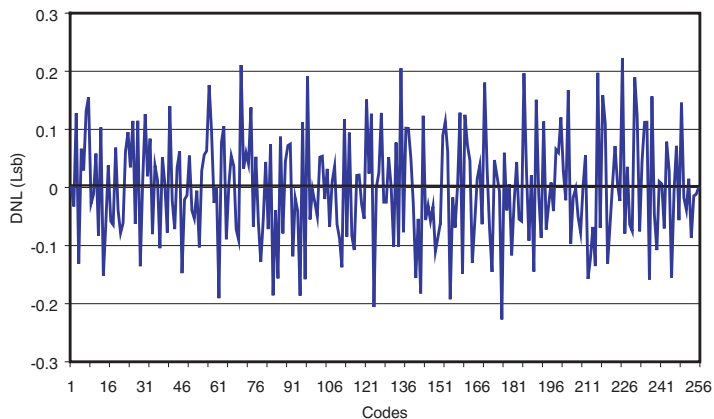

Figure 18. Typical DNL ($F_s = 50$ Msps, $F_{in} = 1$ MHz, Saturated Input)



Typical Dynamic Performances Versus Sampling Frequency

Figure 19. ENOB Versus Sampling Frequency in Nyquist Conditions ($F_{in} = F_s/2$)

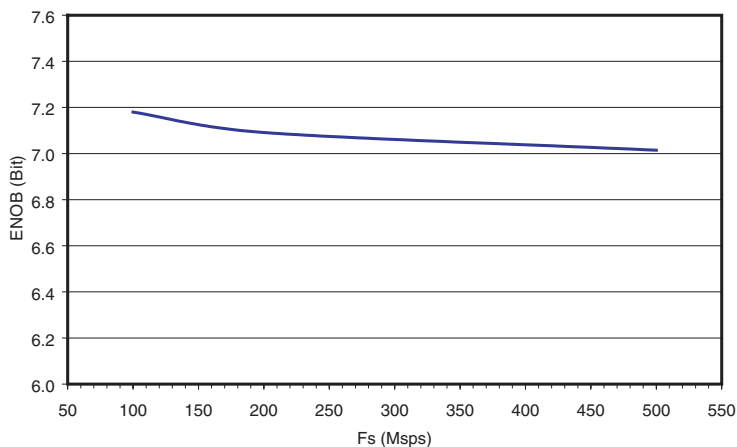

Figure 20. SFDR Versus Sampling Frequency in Nyquist Conditions ($F_{in} = F_s/2$)

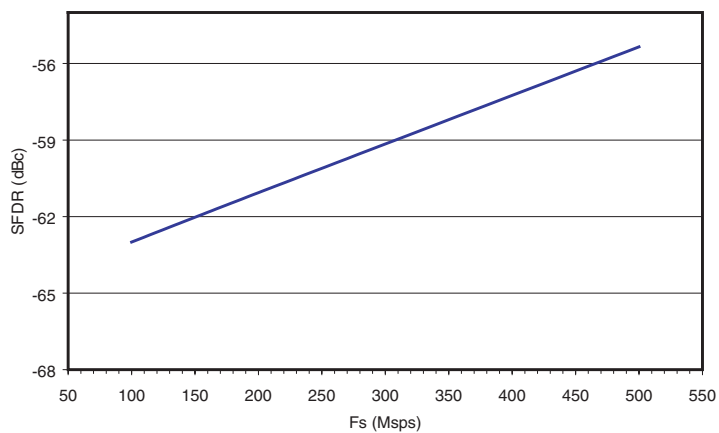

Figure 21. THD Versus Sampling Frequency in Nyquist Conditions ($F_{in} = F_s/2$)

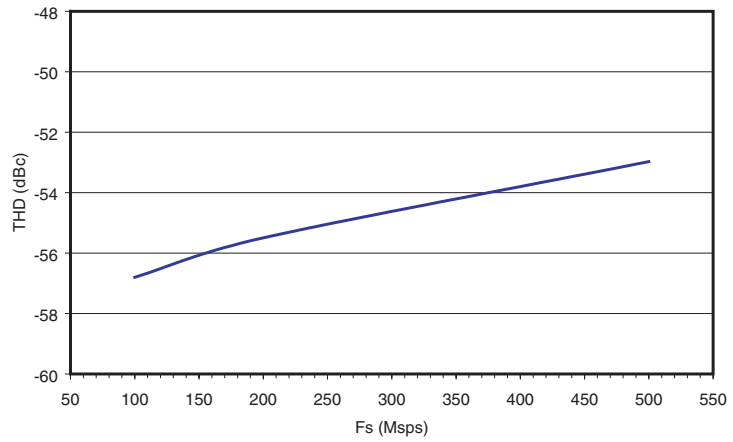
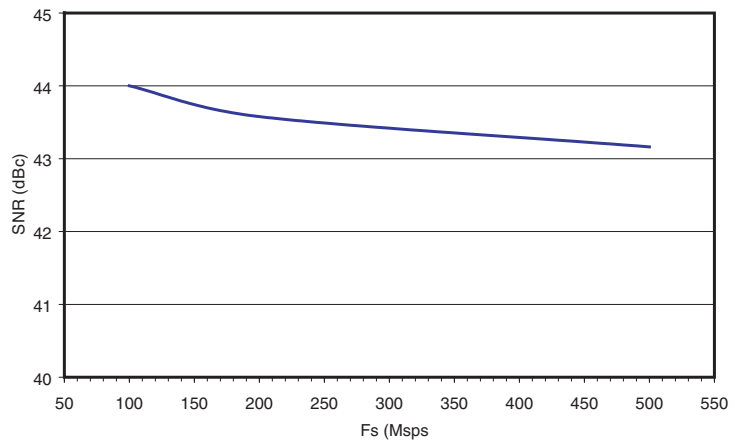

Figure 22. SNR Versus Sampling Frequency in Nyquist Conditions ($F_{in} = F_s/2$)



Typical Dynamic Performances Versus Input Frequency

Figure 23. ENOB Versus Input Frequency ($F_s = 500$ Msp/s)

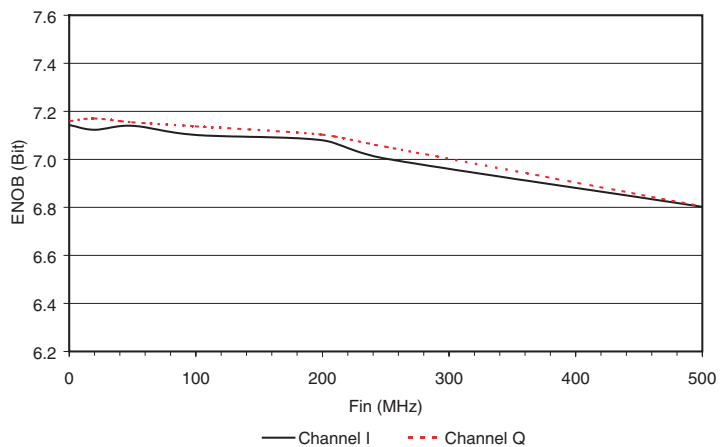

Figure 24. SFDR Versus Input Frequency ($F_s = 500$ Msp/s)

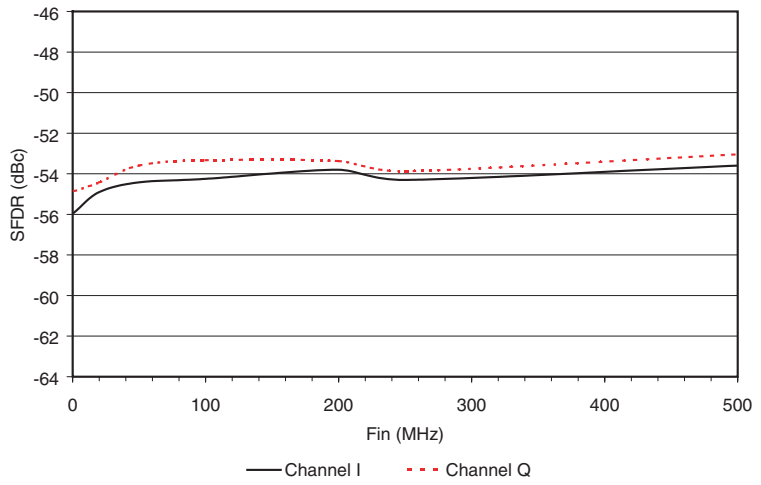

Figure 25. THD Versus Input Frequency ($F_s = 500$ Msp/s)

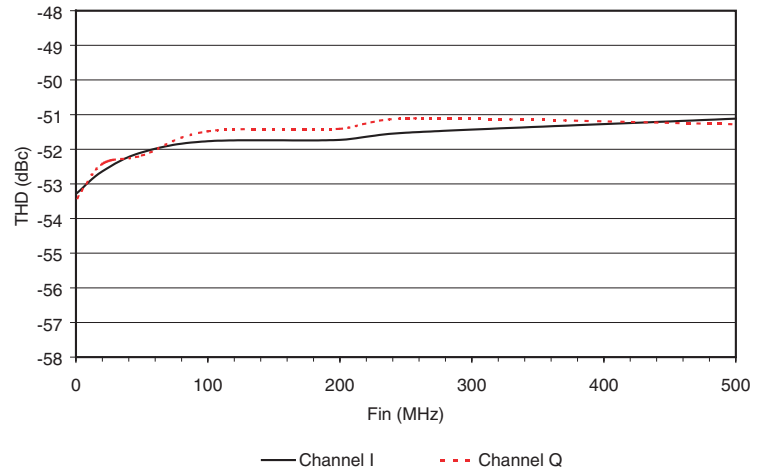
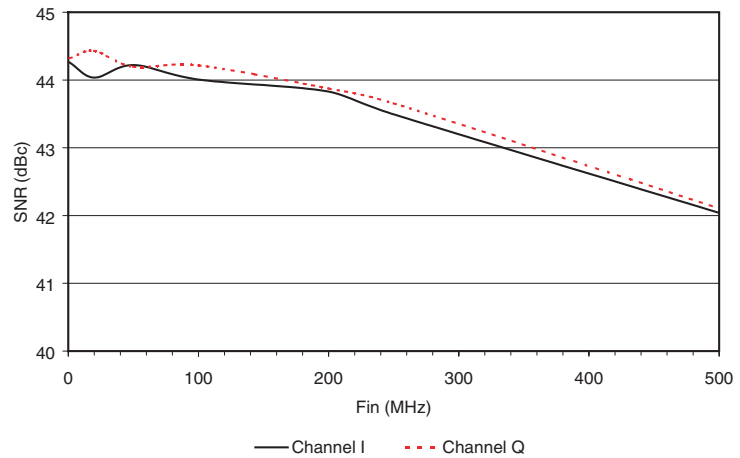

Figure 26. SNR Versus Input Frequency ($F_s = 500$ Msp/s)



Typical Signal Spectrum

Figure 27. $F_s = 500$ MspS and $F_{in} = 20$ MHz (1:2 DMUX, $F_s/4$ DR Type
 $F_iSDA = -35$ ps, $ISA = -50$ ps)

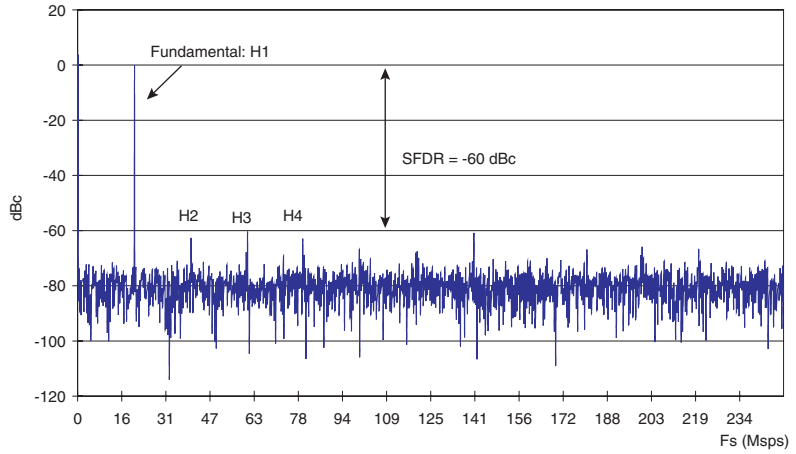

Figure 28. $F_s = 500$ MspS and $F_{in} = 250$ MHz (1:2 DMUX, $F_s/4$ DR Type
 $F_iSDA = -35$ ps, $ISA = -50$ ps)

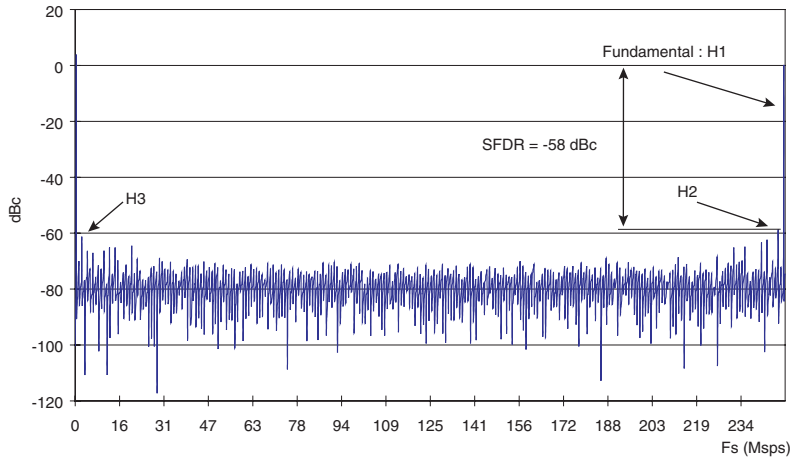
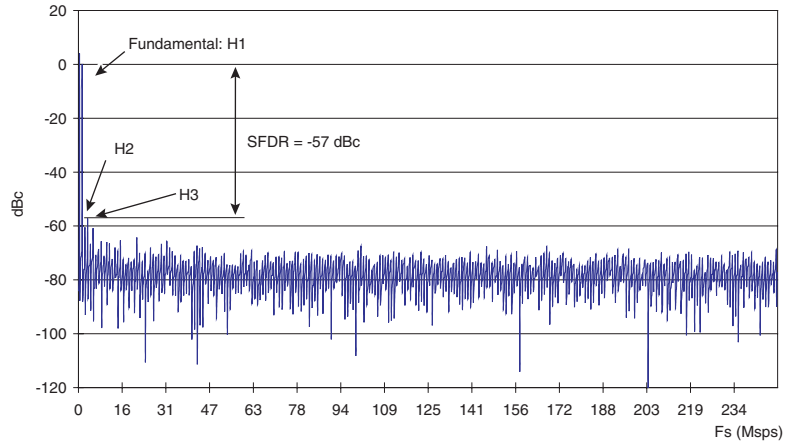
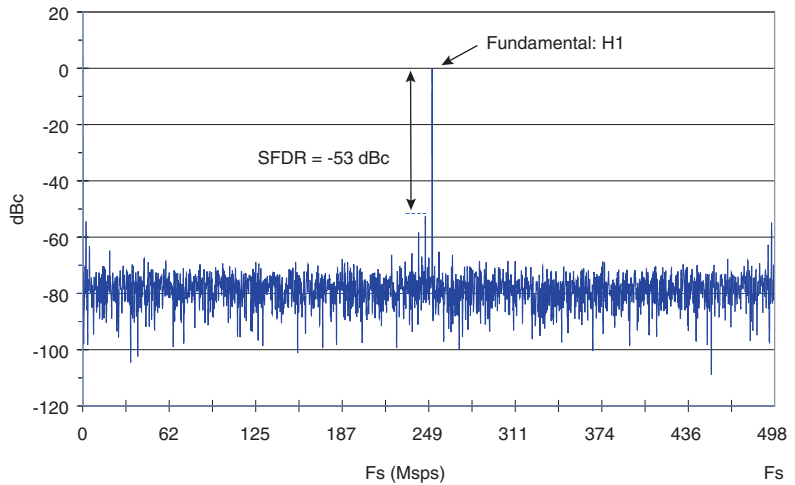

Figure 29. $F_s = 500$ MspS and $F_{in} = 500$ MHz (1:2 DMUX, $F_s/4$ DR Type
 $F_iSDA = -35$ ps, $ISA = -50$ ps)



Note: The spectra are given with respect to the output clock frequency observed by the acquisition system (Figures 27 to 29).

Figure 30. $F_s = 500$ MspS and $F_{in} = 250$ MHz (Interleaving Mode $F_{int} = 1$ GspS
 1:1 DMUX, $F_iSDA = -35$ ps, $ISA = -50$ ps)



**Typical Performance
Sensitivity Versus Power
Supplies and
Temperature**

Figure 31. ENOB Versus V_{CCA} ($F_s = 500$ Msps, $F_{in} = 250$ MHz, 1:2 DMUX, $F_s/4$ DR Type, $ISA = -50$ ps)

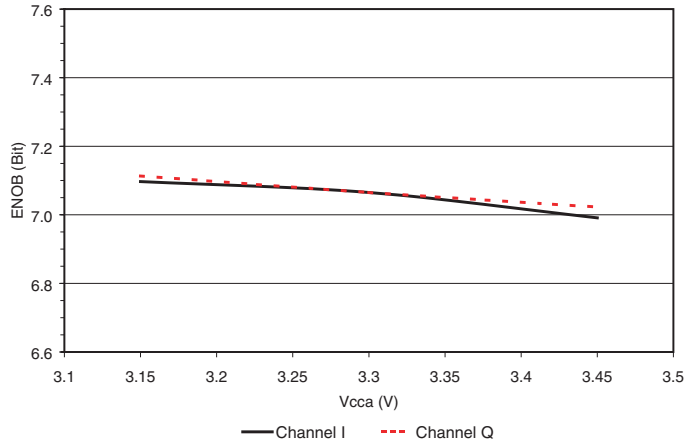

Figure 32. SFDR Versus V_{CCA} ($F_s = 500$ Msps, $F_{in} = 250$ MHz, 1:2 DMUX, $F_s/4$ DR Type, $ISA = -50$ ps)

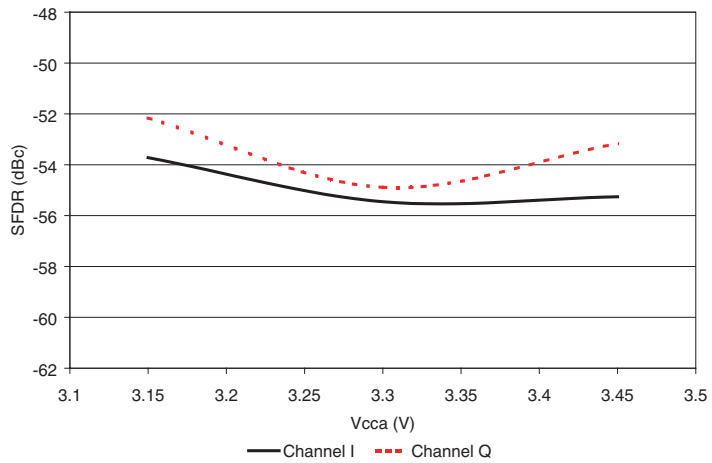

Figure 33. THD Versus V_{CCA} ($F_s = 500$ Msp, $F_{in} = 250$ MHz, 1:2 DMUX, $F_s/4$ DR Type, $ISA = -50$ ps)

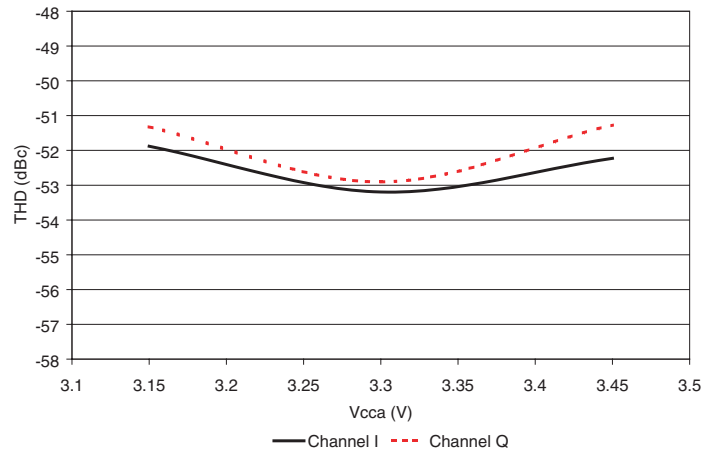

Figure 34. SNR Versus V_{CCA} ($F_s = 500$ Msp, $F_{in} = 250$ MHz, 1:2 DMUX, $F_s/4$ DR Type, $ISA = -50$ ps)

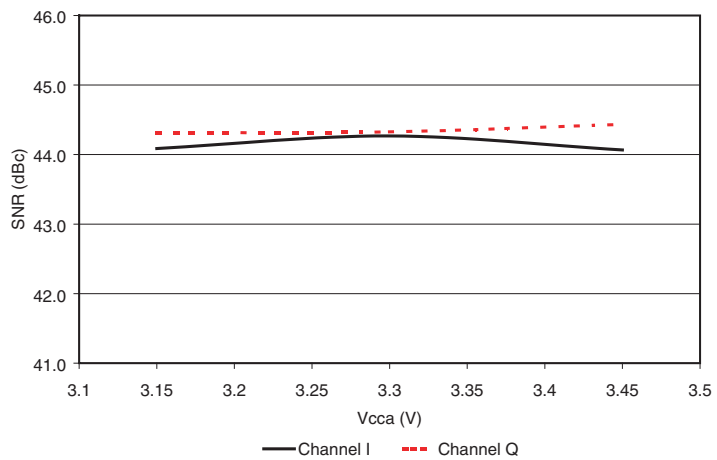

Figure 35. ENOB Versus Junction Temperature ($F_s = 500$ Msps, $F_{in} = 250$ MHz, 1:2 DMUX, $F_s/4$ DR Type, $ISA = -50$ ps)

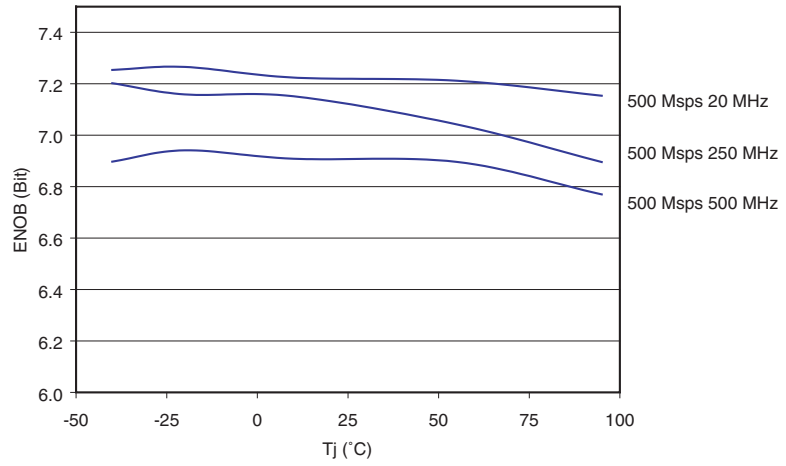

Figure 36. SFDR Versus Junction Temperature ($F_s = 500$ Msps, $F_{in} = 250$ MHz, 1:2 DMUX, $F_s/4$ DR Type, $ISA = -50$ ps)

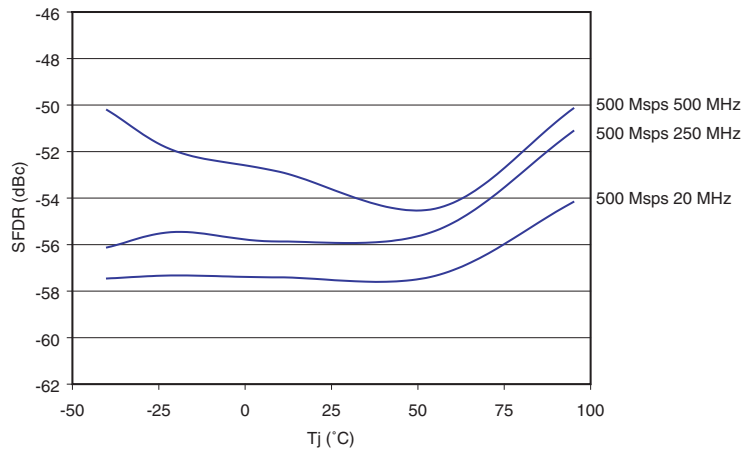

Figure 37. THD Versus Junction Temperature (Fs = 500 Msps, Fin = 250 MHz, 1:2 DMUX, Fs/4 DR Type, ISA = -50 ps)

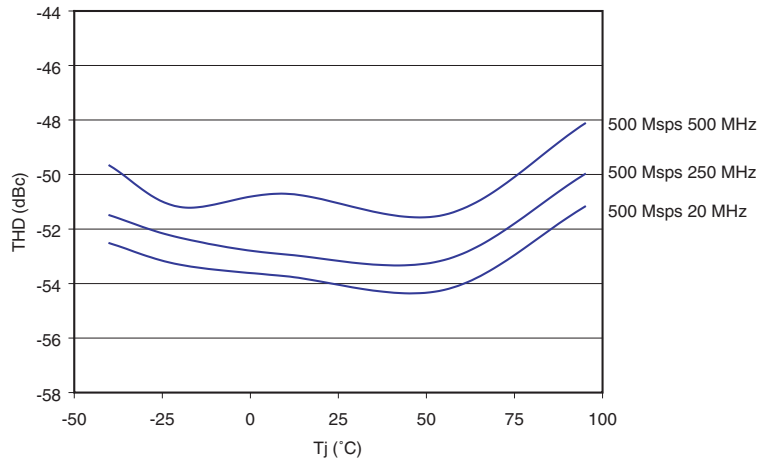
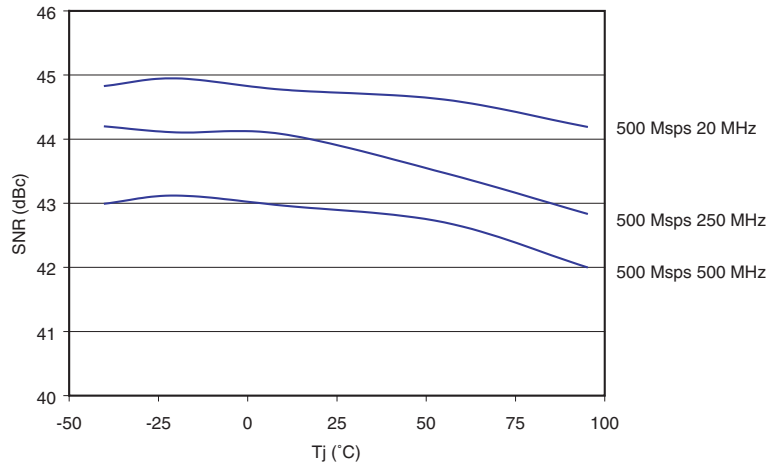

Figure 38. SNR Versus Junction Temperature (Fs = 500 Msps, Fin = 250 MHz, 1:2 DMUX, Fs/4 DR Type, ISA = -50 ps)



Test and Control Features

3-wire Serial Interface Control Setting

Table 9. 3-wire Serial Interface Control Settings

Mode	Characteristics
Mode = 1 (2.25V)	3-wire serial bus interface activated
Mode = 0 (0V)	3-wire serial bus interface deactivated Nominal setting: Dual channel I and Q activated One clock I 0 dB gain DMUX mode 1:1 DRDA I & Q = 0 ps ISA I & Q = 0 ps FiSDA Q = 0 ps Binary output Decimation test mode OFF Calibration setting OFF Data Ready = $F_s / 2$

3-wire Serial Interface and Data Description

The 3-wire bus is activated with the control bit mode set to 1. The length of the word is 19 bits: 16 for the data and 3 for the address. The maximum clock frequency is 50 MHz.

Table 10. 3-wire Serial Interface Address Setting Description

Address	Setting
000	Standby Gray/binary mode 1:1 or 1:2 DMUX mode Analog input MUX Clock selection Auto-calibration Decimation test mode Data Ready Delay Adjust
001	Analog gain adjustment Data7 to Data0: gain channel I Data15 to Data8: gain channel Q Code 00000000: -1.5 dB Code 10000000: 0 dB Code 11111111: 1.5 dB Steps: 0.011 dB
010	Offset compensation Data7 to Data0: offset channel I Data15 to Data8: offset channel Q Data7 and Data15: sign bits Code 11111111b: 31.75 LSB Code 10000000b: 0 LSB Code 00000000b: 0 LSB Code 01111111b: -31.75 LSB Steps: 0.25 LSB Maximum correction: ± 31.75 LSB
011	Gain compensation Data6 to Data0: channel I/Q (Q is matched to I) Code 11111111b: -0.315 dB Code 10000000b: 0 dB Code 00000000b: 0 dB Code 01111111b: 0.315 dB Steps: 0.005 dB Data6: sign bit
100	Internal Settling Adjustment (ISA) Data2 to Data0: channel I Data5 to Data3: channel Q Data15 to Data6: 1000010000

Table 11. 3-wire Serial Interface Data Setting Description

Setting for Address: 000	D15	D14	D13	D12	D11	D10	D9 ⁽¹⁾	D8	D7	D6	D5	D4	D3	D2	D1	D0
Full standby mode	X	X	X	X	X	X	0	X	X	X	X	X	X	X	1	1
Standby channel I ⁽²⁾	X	X	X	X	X	X	0	X	X	X	X	X	X	X	0	1
Standby channel Q ⁽³⁾	X	X	X	X	X	X	0	X	X	X	X	X	X	X	1	0
No standby mode	X	X	X	X	X	X	0	X	X	X	X	X	X	X	0	0
Binary output mode	X	X	X	X	X	X	0	X	X	X	X	X	X	1	X	X
Gray output mode	X	X	X	X	X	X	0	X	X	X	X	X	X	0	X	X
DMUX 1:2 mode	X	X	X	X	X	X	0	X	X	X	X	X	1	X	X	X
DMUX 1:1 mode	X	X	X	X	X	X	0	X	X	X	X	X	0	X	X	X
Analog selection mode Input I →ADC I Input Q →ADC Q	X	X	X	X	X	X	0	X	X	X	1	1	X	X	X	X
Analog selection mode Input I →ADC I Input I →ADC Q	X	X	X	X	X	X	0	X	X	X	1	0	X	X	X	X
Analog selection mode Input Q →ADC I Input Q →ADC Q	X	X	X	X	X	X	0	X	X	X	0	X	X	X	X	X
Clock Selection mode CLKI →ADC I CLKQ →ADC Q	X	X	X	X	X	X	0	X	1	1	X	X	X	X	X	X
Clock selection mode CLKI →ADC I CLKI →ADC Q	X	X	X	X	X	X	0	X	1	0	X	X	X	X	X	X
Clock selection mode CLKI →ADC I CLKIN →ADC Q	X	X	X	X	X	X	0	X	0	X	X	X	X	X	X	X
Decimation OFF mode	X	X	X	X	X	X	0	0	X	X	X	X	X	X	X	X
Decimation ON mode	X	X	X	X	X	X	0	1	X	X	X	X	X	X	X	X
Keep last calibration calculated value ⁽⁴⁾ No calibration phase	X	X	X	X	0	1	0	X	X	X	X	X	X	X	X	X
No calibration phase ⁽⁵⁾ No calibration value	X	X	X	X	0	0	0	X	X	X	X	X	X	X	X	X
Start a new calibration phase	X	X	X	X	1	1	0	X	X	X	X	X	X	X	X	X

Table 11. 3-wire Serial Interface Data Setting Description (Continued)

Setting for Address: 000	D15	D14	D13	D12	D11	D10	D9 ⁽¹⁾	D8	D7	D6	D5	D4	D3	D2	D1	D0
Control wait bit calibration ⁽⁶⁾	X	X	a	b	X	X	0	X	X	X	X	X	X	X	X	X
In 1:2 DMUX FDataReady I & Q = Fs/2	X	0	X	X	X	X	0	X	X	X	X	X	X	X	X	X
In 1:2 DMUX FDataReady I & Q = Fs/4	X	1	X	X	X	X	0	X	X	X	X	X	X	X	X	X

- Notes:
1. D9 must be set to “0”
 2. Mode standby channel I: use analog input I Vini, Vinib and Clocki.
 3. Mode standby channel Q: use analog input Q Vinq, Vinqb and Clockq.
 4. Keep last calibration calculated value - no calibration phase: D11 = 0 and D10 = 1. No new calibration is required. The values taken into account for the gain and offset are either from the last calibration phase or are default values (reset values).
 5. No calibration phase - no calibration value: D11 = 0 and D10 = 0. No new calibration phase is required. The gain and offset compensation functions can be accessed externally by writing in the registers at address 010 for the offset compensation and at address 011 for the gain compensation.
 6. The control wait bit gives the possibility to change the internal setting for the auto-calibration phase:
 - For high clock rates (= 500 Msps) use a = b = 1.
 - For clock rates > 250 Msps and < 500 Msps use a = 1 and b = 0.
 - For clock rates > 125 Msps and < 250 Msps use a = 0 and b = 1.
 - For low clock rates < 125 Msps use a = 0 and b = 0.

3-wire Serial Interface Timing Description

The 3-wire serial interface is a synchronous write-only serial interface made of three wires:

- sclk: serial clock input
- sldn: serial load enable input
- sdata: serial data input

The 3-wire serial interface gives write-only access to as many as 8 different internal registers of up to 16 bits each. The input format is always fixed with 3 bits of register address followed by 16 bits of data. The data and address are entered with the Most Significant Bit (MSB) first.

The write procedure is fully synchronous with the rising clock edge of “sclk” and described in the write chronogram (Figure 39 on page 39).

- “sldn” and “sdata” are sampled on each rising clock edge of “sclk” (clock cycle).
- “sldn” must be set to 1 when no write procedure is performed.
- A minimum of one rising clock edge (clock cycle) with “sldn” at 1 is required for a correct start of the write procedure.
- A write starts on the first clock cycle with “sldn” at 0. “sldn” must stay at 0 during the complete write procedure.
- During the first 3 clock cycles with “sldn” at 0, 3 bits of the register address from MSB (a[2]) to LSB (a[0]) are entered.
- During the next 16 clock cycles with “sldn” at 0, 16 bits of data from MSB (d[15]) to LSB (d[0]) are entered.
- An additional clock cycle with “sldn” at 0 is required for parallel transfer of the serial data d[15:0] into the addressed register with address a[2:0]. This yields 20 clock cycles with “sldn” at 0 for a normal write procedure.

- A minimum of one clock cycle with “sldn” returned at 1 is requested to close the write procedure and make the interface ready for a new write procedure. Any clock cycle where “sldn” is at 1 *before* the write procedure is completed interrupts this procedure and no further data transfer to the internal registers is performed.
- Additional clock cycles with “sldn” at 0 *after* the parallel data transfer to the register (done at the 20th consecutive clock cycle with “sldn” at 0) do not affect the write procedure and are ignored.

It is possible to have only one clock cycle with “sldn” at 1 between two following write procedures.

- 16 bits of data must always be entered even if the internal addressed register has less than 16 bits. Unused bits (usually MSBs) are ignored. Bit signification and bit positions for the internal registers are detailed in Table 10 on page 35.

To reset the registers, the Pin mode can be used as a reset pin for chip initialization, even when the 3-wire serial interface is used.

Figure 39. Write Chronogram

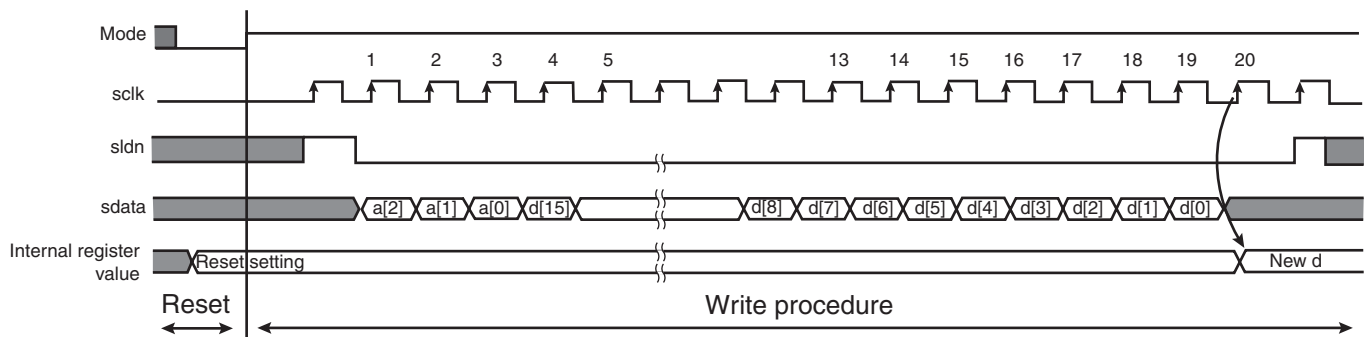

Figure 40. Timing Definition

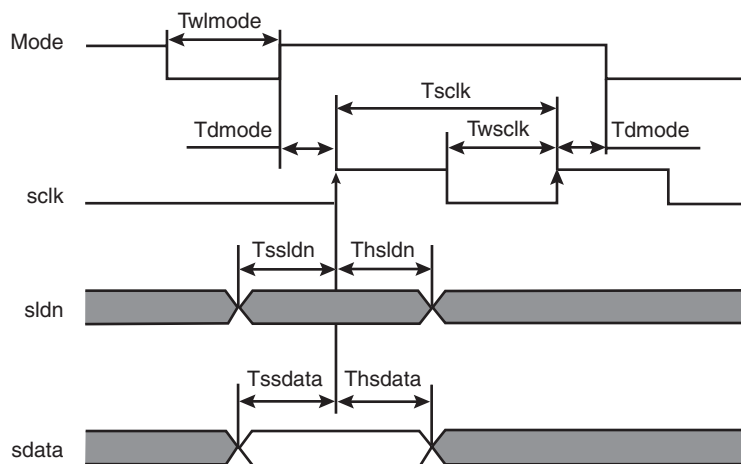

Table 12. Timing Description

Name	Parameter	Value			Unit
		Min	Typ	Max	
Tsclk	Sclk period	20			ns
Twsclk	High or low time of sclk	5			ns
Tssldn	Setup time of sldn before rising edge of sclk	4			ns
Thsldn	Hold time of sldn after rising edge of sclk	2			ns
Tssdata	Setup time of sdata before rising edge of sclk	4			ns
Thsdata	Hold time of sdata after rising edge of sclk	2			ns
Twlmode	Minimum low pulse width of mode	5			ns
Tdmode	Minimum delay between an edge of mode and the rising edge of sclk	10			ns

Calibration Description

The AT84AD004 offers the possibility of reducing offset and gain matching between the two ADC cores. An internal digital calibration may start right after the 3-wire serial interface has been loaded (using data D12 of the 3-wire serial interface with address 000).

The beginning of calibration disables the two ADCs and a standard data acquisition is performed. The output bit CAL goes to a high level during the entire calibration phase. When this bit returns to a low level, the two ADCs are calibrated with offset and gain and can be used again for a standard data acquisition.

If only one channel is selected (I or Q) the offset calibration duration is divided by two and no gain calibration between the two channels is necessary.

Figure 41. Internal Timing Calibration



The Tcal duration is a multiple of the clock frequency ClockI (master clock). Even if a dual clock scheme is used during calibration, ClockQ will not be used.

The control wait bits (D13 and D14) give the possibility of changing the calibration's setting depending on the clock's frequency:

- For high clock rates (= 500 Msps) use a = b = 1, Tcal = 10112 clock I periods.
- For clock rates > 250 Msps and < 500 Msps use a = 1, b = 0, Tcal = 6016 clock I periods.
- For clock rates > 125 Msps and < 250 Msps use a = 0, b = 1, Tcal = 3968 clock I periods.
- For low clock rates (< 125 Msps) use a = 0, b = 0, Tcal = 2944 clock I periods.

The calibration phase is necessary when using the AT84AD004 in interlace mode, where one analog input is sampled at both ADC cores on the common input clock's rising and falling edges. This operation is equivalent to converting the analog signal at twice the clock frequency

Table 13. Matching Between Channels

Parameter	Value			Unit
	Min	Typ	Max	
Gain error (single channel I or Q) without calibration		0		LSB
Gain error (single channel I or Q) with calibration	-0.5	0	0.5	LSB
Offset error (single channel I or Q) without calibration		0		LSB
Offset error (single channel I or Q) with calibration	-0.5	0	0.5	LSB
Mean offset code without calibration (single channel I or Q)		127.5		
Mean offset code with calibration (single channel I or Q)	127	127.5	128	

During the ADC's auto-calibration phase, the dual ADC is set with the following:

- Decimation mode ON
- 1:1 DMUX mode
- Binary mode

Any external action applied to any signal of the ADC's registers is inhibited during the calibration phase.

Gain and Offset Compensation Functions

It is also possible for the user to have external access to the ADC's gain and offset compensation functions:

- Offset compensation between I and Q channels (at address 010)
- Gain compensation between I and Q channels (at address 011)

To obtain manual access to these two functions, which are used to set the offset to middle code 127.5 and to match the gain of channel Q with that of channel I (if only one channel is used, the gain compensation does not apply), it is necessary to set the ADC to "manual" mode by writing 0 at bits D11 and D10 of address 000.

Built-in Test (BIT)

A Built-in Test (BIT) function is available to allow rapid testing of the device's I/O by either applying a defined static pattern to the ADC or by generating a dynamic ramp at the ADC's output. This function is controlled via the 3-wire bus interface at address 101.

- The BIT is active when Data0 = 1 at address 110.
- The BIT is inactive when Data0 = 0 at address 110.
- The Data1 bit allows choosing between static mode (Data1 = 0) and dynamic mode (Data1 = 1).

When the static BIT is selected (Data1 = 0), it is possible to write any 8-bit pattern by defining the Data9 to Data2 bits. Port B then outputs an 8-bit pattern equal to *Data9 ... Data2*, and Port A outputs an 8-bit pattern equal to *NOT (Data9 ... Data2)*.

Example:

Address = 110

Data =

D15	D14	D13	D12	D11	D10	D9	D8	D7	D6	D5	D4	D3	D2	D1	D0
X	X	X	X	X	X	0	1	0	1	0	1	0	1	0	1

One should then obtain 01010101 on Port B and 10101010 on Port A.

When the dynamic mode is chosen (Data1 = 1) port B outputs a rising ramp while Port A outputs a decreasing one.

Note: In dynamic mode, use the DRDA function to align the edges of CLKO with the middle of the data.

Decimation Mode

The decimation mode is provided to enable rapid testing of the ADC. In decimation mode, one data out of 16 is output, thus leading to a maximum output rate of 31.25 Msps.

Note: Frequency (CLKO) = frequency (Data) = Frequency (CLKI)/16.

Die Junction Temperature Monitoring Function

A die junction temperature measurement setting is included on the board for junction temperature monitoring.

The measurement method forces a 1 mA current into a diode-mounted transistor.

Caution should be given to respecting the polarity of the current.

In any case, one should make sure the maximum voltage compliance of the current source is limited to a maximum of 1V or use a resistor serial-mounted with the current source to avoid damaging the transistor device (this may occur if the current source is reverse-connected).

The measurement setup is illustrated in Figure 42.

Figure 42. Die Junction Temperature Monitoring Setup

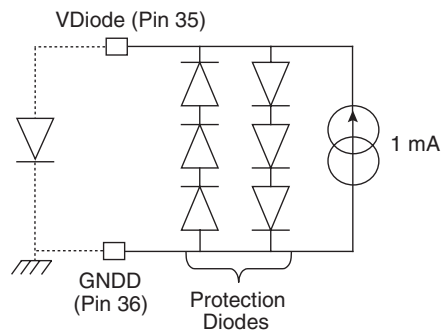

The VBE diode's forward voltage in relation to the junction temperature (in steady-state conditions) is shown in Figure 43.

Figure 43. Diode Characteristics Versus T_J

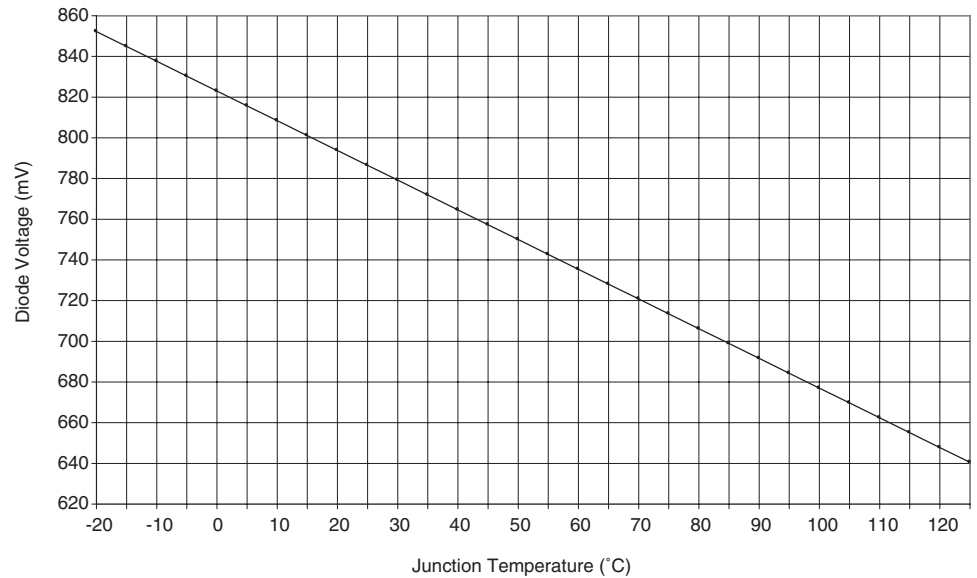

VtestI, VtestQ

VtestI and VtestQ pins are for internal test use only. These two signals must be left open.

Equivalent Input/Output Schematics

Figure 44. Simplified Input Clock Model

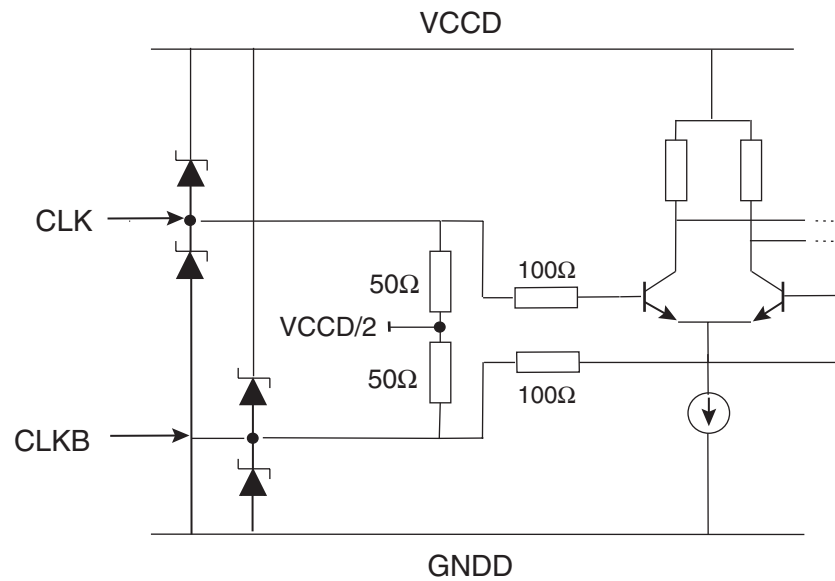

Figure 45. Simplified Data Ready Reset Buffer Model

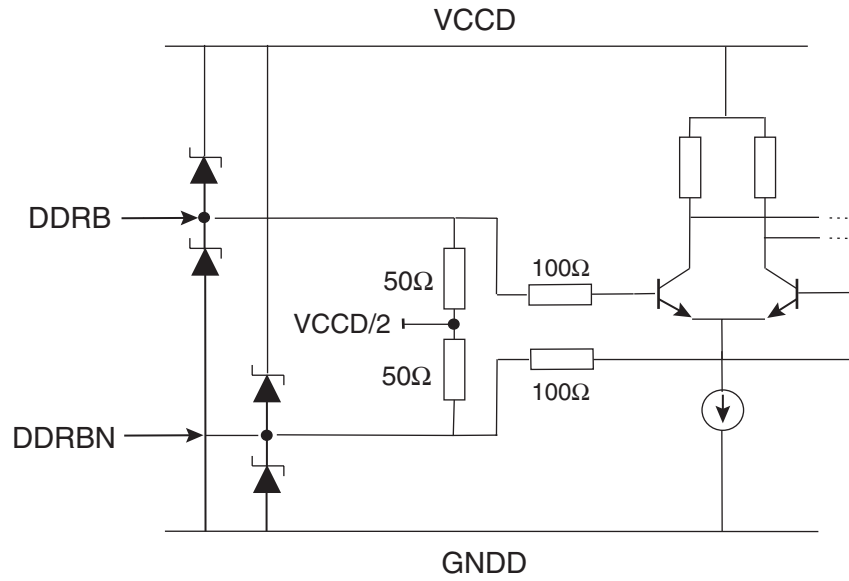

Figure 46. Analog Input Model

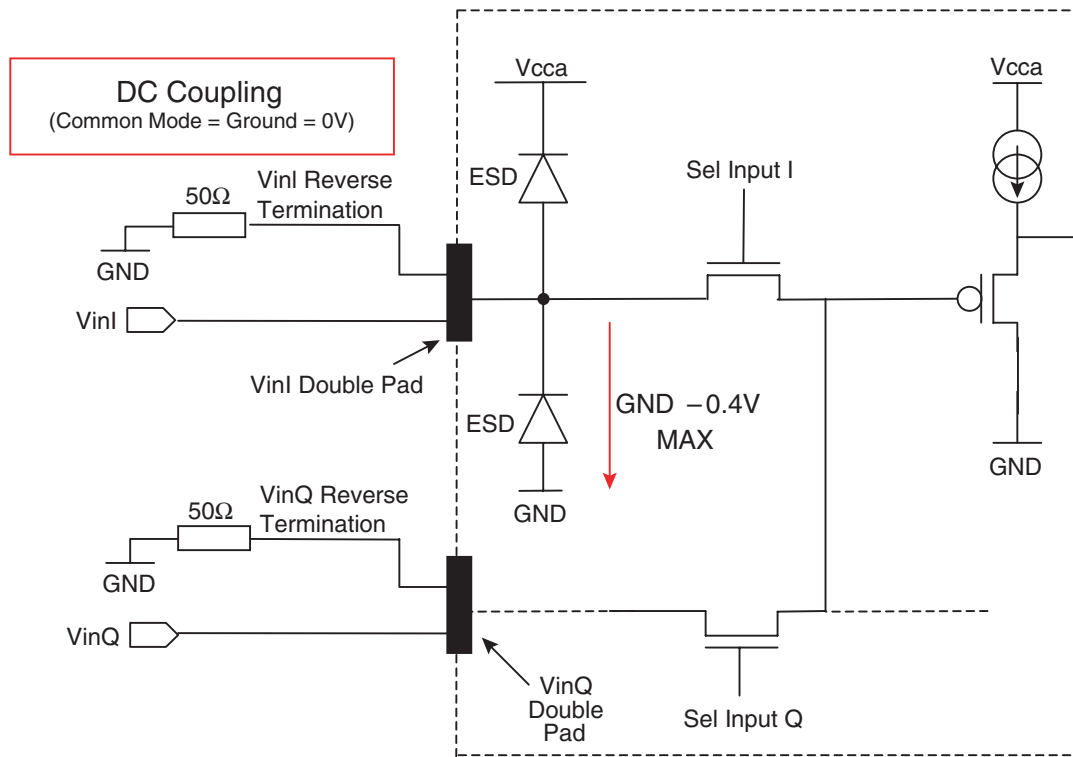
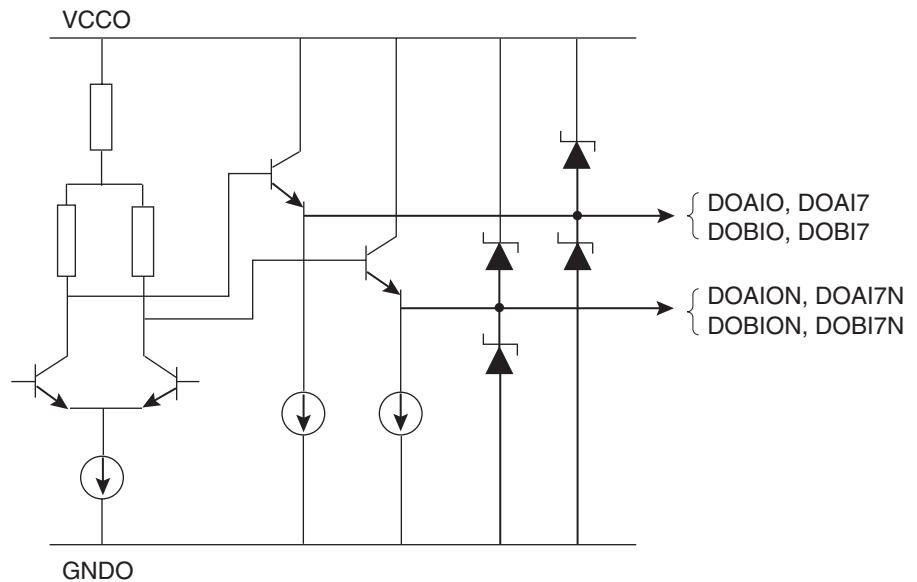

Figure 47. Data Output Buffer Model



Definitions of Terms

Table 14. Definitions of Terms

Abbreviation	Definition	Description
BER	Bit Error Rate	The probability of exceeding a specified error threshold for a sample at a maximum specified sampling rate. An error code is a code that differs by more than ± 4 LSB from the correct code
DNL	Differential Non-Linearity	The differential non-linearity for an output code i is the difference between the measured step size of code i and the ideal LSB step size. DNL (i) is expressed in LSBs. DNL is the maximum value of all DNL (i). A DNL error specification of less than 1 LSB guarantees that there are no missing output codes and that the transfer function is monotonic
ENOB	Effective Number of Bits	$ENOB = \frac{SINAD - 1.76 + 20 \log \left[\frac{A}{F_s/2} \right]}{6.02}$ Where A is the actual input amplitude and F_s is the full scale range of the ADC under test
FPBW	Full Power Input Bandwidth	The analog input frequency at which the fundamental component in the digitally reconstructed output waveform has fallen by 3 dB with respect to its low frequency value (determined by FFT analysis) for input at full-scale -1 dB (-1 dBFS)
IMD	Inter-Modulation Distortion	The two tones intermodulation distortion (IMD) rejection is the ratio of either of the two input tones to the worst third order intermodulation products
INL	Integral Non-Linearity	The integral non-linearity for an output code i is the difference between the measured input voltage at which the transition occurs and the ideal value of this transition. INL (i) is expressed in LSBs and is the maximum value of all INL (i)
JITTER	Aperture uncertainty	The sample-to-sample variation in aperture delay. The voltage error due to jitters depends on the slew rate of the signal at the sampling point
NPR	Noise Power Ratio	The NPR is measured to characterize the ADC's performance in response to broad bandwidth signals. When applying a notch-filtered broadband white noise signal as the input to the ADC under test, the Noise Power Ratio is defined as the ratio of the average out-of-notch to the average in-notch power spectral density magnitudes for the FFT spectrum of the ADC output sample test

Table 14. Definitions of Terms (Continued)

Abbreviation	Definition	Description
ORT	Overshoot Recovery Time	The time to recover a 0.2% accuracy at the output, after a 150% full-scale step applied on the input is reduced to midscale
PSRR	Power Supply Rejection Ratio	The ratio of input offset variation to a change in power supply voltage
SFDR	Spurious Free Dynamic Range	The ratio expressed in dB of the RMS signal amplitude, set at 1 dB below full-scale, to the RMS value of the highest spectral component (peak spurious spectral component). The peak spurious component may or may not be a harmonic. It may be reported in dB (related to the converter -1 dB full-scale) or in dBc (related to the input signal level)
SINAD	Signal to Noise and Distortion Ratio	The ratio expressed in dB of the RMS signal amplitude, set to 1 dB below full-scale (-1 dBFS) to the RMS sum of all other spectral components including the harmonics, except DC
SNR	Signal to Noise Ratio	The ratio expressed in dB of the RMS signal amplitude, set to 1 dB below full-scale, to the RMS sum of all other spectral components excluding the first 9 harmonics
SSBW	Small Signal Input Bandwidth	The analog input frequency at which the fundamental component in the digitally reconstructed output waveform has fallen by 3 dB with respect to its low frequency value (determined by FFT analysis) for input at full-scale -10 dB (-10 dBFS)
TA	Aperture delay	The delay between the rising edge of the differential clock inputs (CLK, CLKB) [zero crossing point] and the time at which VIN and VINB are sampled
TC	Encoding Clock period	TC1 = minimum clock pulse width (high) TC = TC1 + TC2 TC2 = minimum clock pulse width (low)
TD1	Time Delay from Data Transition to Data Ready	The general expression is $TD1 = TC1 + TDR - TDO$ with $TC = TC1 + TC2 = 1$ encoding clock period
TD2	Time Delay from Data Ready to Data	The general expression is $TD2 = TC2 + TDR - TDO$ with $TC = TC1 + TC2 = 1$ encoding clock period
TDO	Digital Data Output Delay	The delay from the rising edge of the differential clock inputs (CLK, CLKB) [zero crossing point] to the next point of change in the differential output data (zero crossing) with a specified load
TDR	Data Ready Output Delay	The delay from the falling edge of the differential clock inputs (CLK, CLKB) [zero crossing point] to the next point of change in the differential output data (zero crossing) with a specified load
TF	Fall Time	The time delay for the output data signals to fall from 20% to 80% of delta between the low and high levels
THD	Total Harmonic Distortion	The ratio expressed in dB of the RMS sum of the first 9 harmonic components to the RMS input signal amplitude, set at 1 dB below full-scale. It may be reported in dB (related to the converter -1 dB full-scale) or in dBc (related to the input signal level)
TPD	Pipeline Delay	The number of clock cycles between the sampling edge of an input data and the associated output data made available (not taking into account the TDO)
TR	Rise Time	The time delay for the output data signals to rise from 20% to 80% of delta between the low and high levels

Table 14. Definitions of Terms (Continued)

Abbreviation	Definition	Description
TRDR	Data Ready Reset Delay	The delay between the falling edge of the Data Ready output asynchronous reset signal (DDRB) and the reset to digital zero transition of the Data Ready output signal (DR)
TS	Settling Time	The time delay to rise from 10% to 90% of the converter output when a full-scale step function is applied to the differential analog input
VSWR	Voltage Standing Wave Ratio	The VSWR corresponds to the ADC input insertion loss due to input power reflection. For example, a VSWR of 1.2 corresponds to a 20 dB return loss (99% power transmitted and 1% reflected)

Using the AT84AD004 Dual 8-bit 500 Msp/s ADC

Decoupling, Bypassing and Grounding of Power Supplies

The following figures show the recommended bypassing, decoupling and grounding schemes for the dual 8-bit 500 Msp/s ADC power supplies.

Figure 48. V_{CCD} and V_{CCA} Bypassing and Grounding Scheme

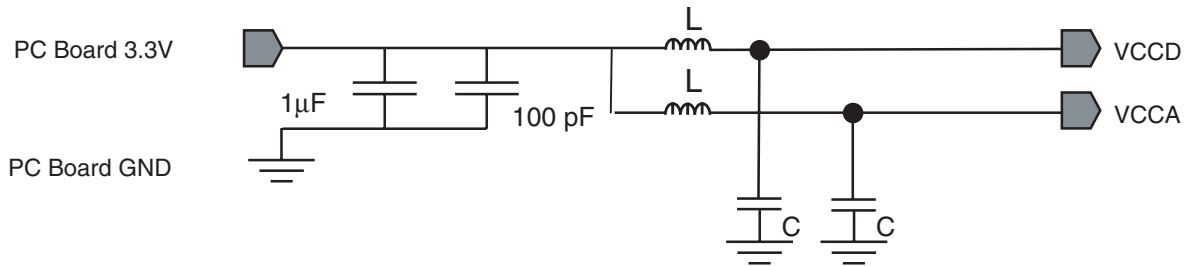
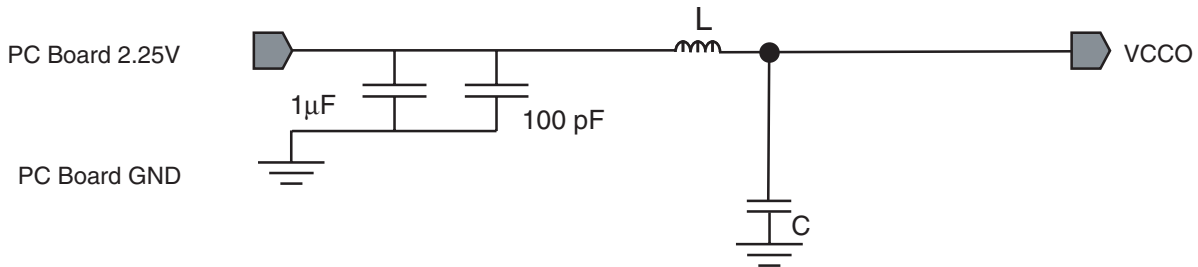
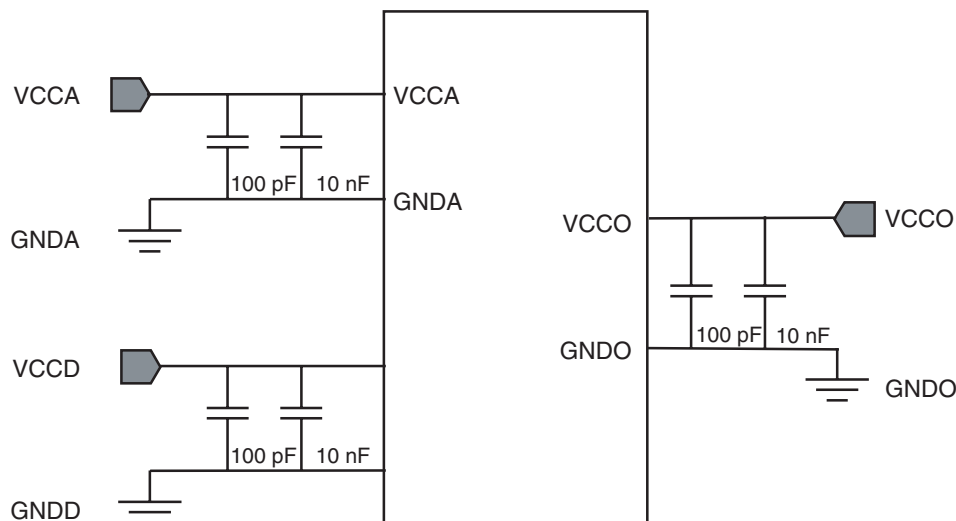

Figure 49. V_{CCO} Bypassing and Grounding Scheme



Note: L and C values must be chosen in accordance with the operating frequency of the application.

Figure 50. Power Supplies Decoupling Scheme



Note: The bypassing capacitors (1 μ F and 100 pF) should be placed as close as possible to the board connectors, whereas the decoupling capacitors (100 pF and 10 nF) should be placed as close as possible to the device.

Analog Input Implementation

The analog inputs of the dual ADC have been designed with a double pad implementation as illustrated in Figure 51. The reverse pad for each input should be tied to ground via a 50Ω resistor.

The analog inputs must be used in differential mode only.

Figure 51. Termination Method for the ADC Analog Inputs in DC Coupling Mode

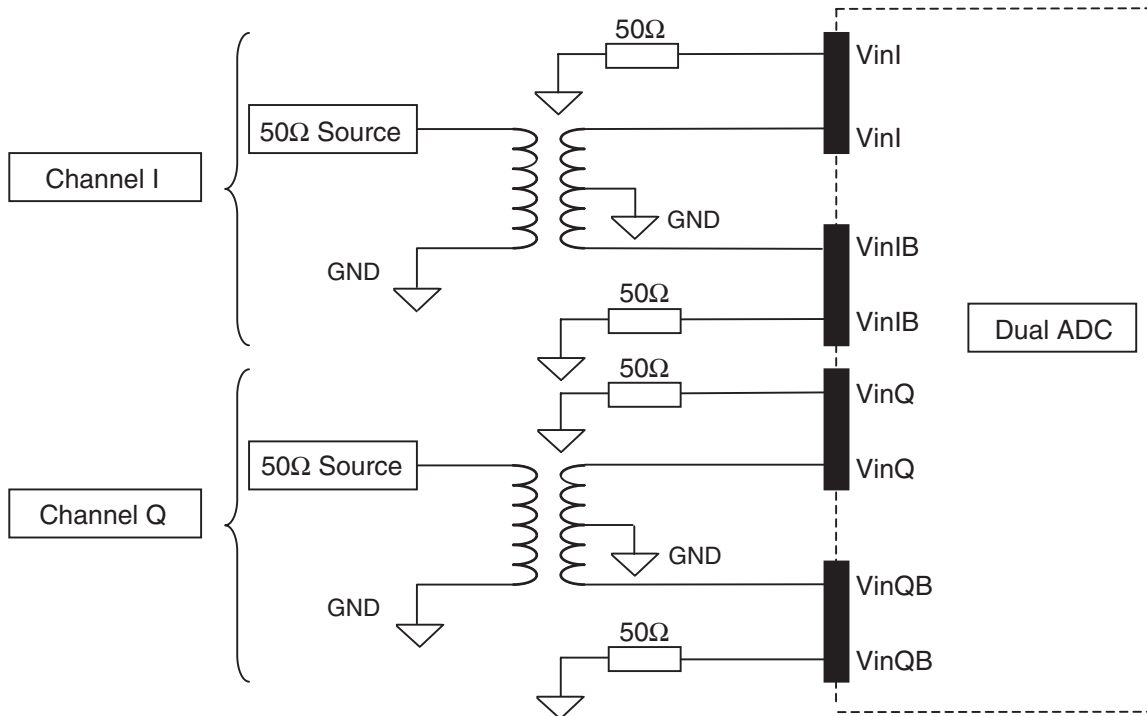
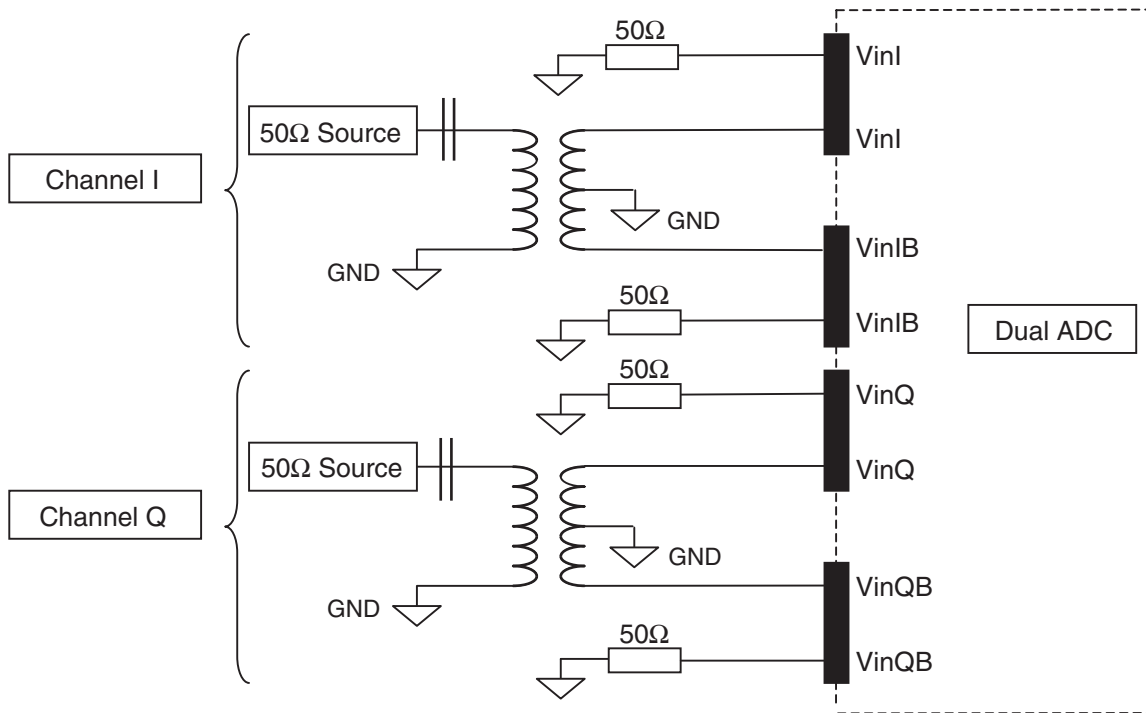

Figure 52. Termination Method for the ADC Analog Inputs in AC Coupling Mode



Clock Implementation

The ADC features two different clocks (I or Q) that must be implemented as shown in Figure 53. Each path must be AC coupled with a 100 nF capacitor.

Figure 53. Differential Termination Method for Clock I or Clock Q

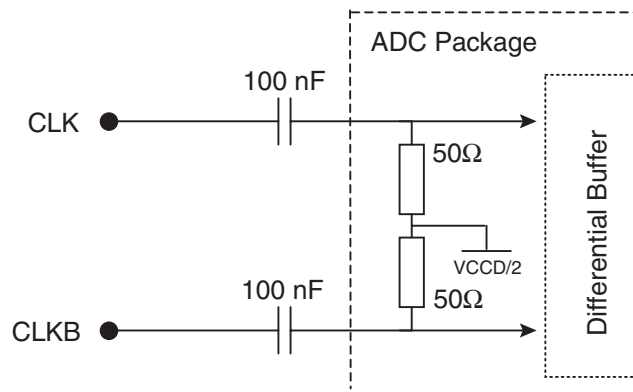

Note: When only clock I is used, it is not necessary to add the capacitors on the CLKQ and CLKQN signal paths; they may be left floating.

Figure 54. Single-ended Termination Method for Clock I or Clock Q

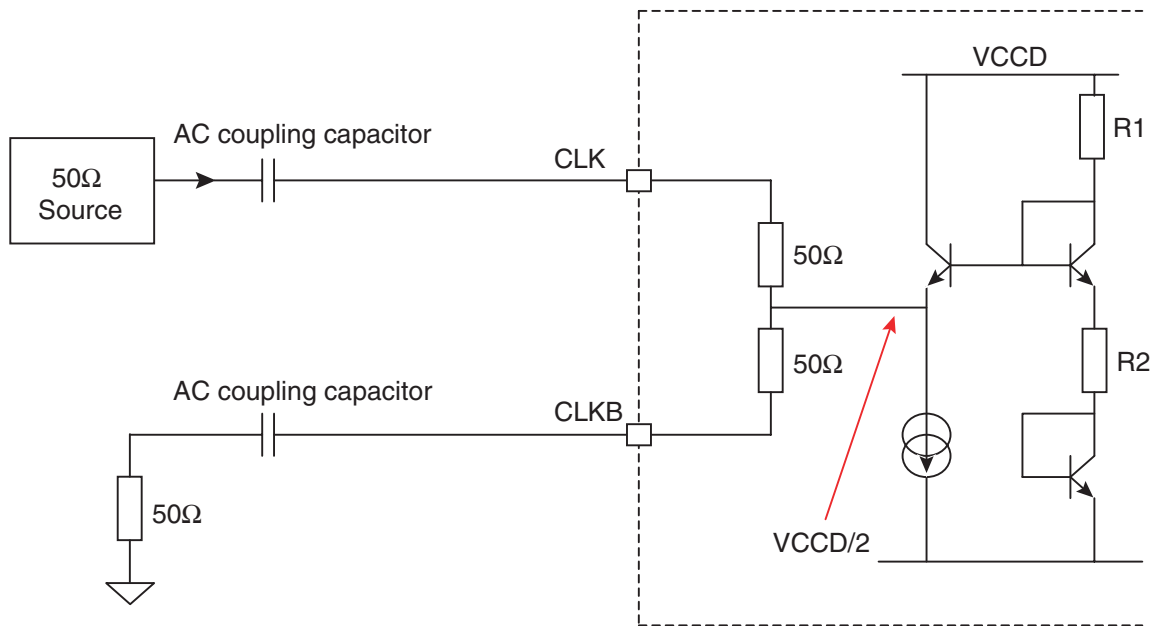

Output Termination in 1:1 Ratio

When using the integrated DMUX in 1:1 ratio, the valid port is port A. Port B remains unused.

Port A functions in LVDS mode and the corresponding outputs (DOAI or DOAQ) have to be 100Ω differentially terminated as shown in Figure 55 on page 52.

The pins corresponding to Port B (DOBI or DOBQ pins) must be left floating (in high impedance state).

Figure 55 on page 52 is an example of a 1:1 ratio of the integrated DMUX for channel I (the same applies to channel Q).

Figure 55. Example of Termination for Channel I Used in DMUX 1:1 Ratio (Port B Unused)

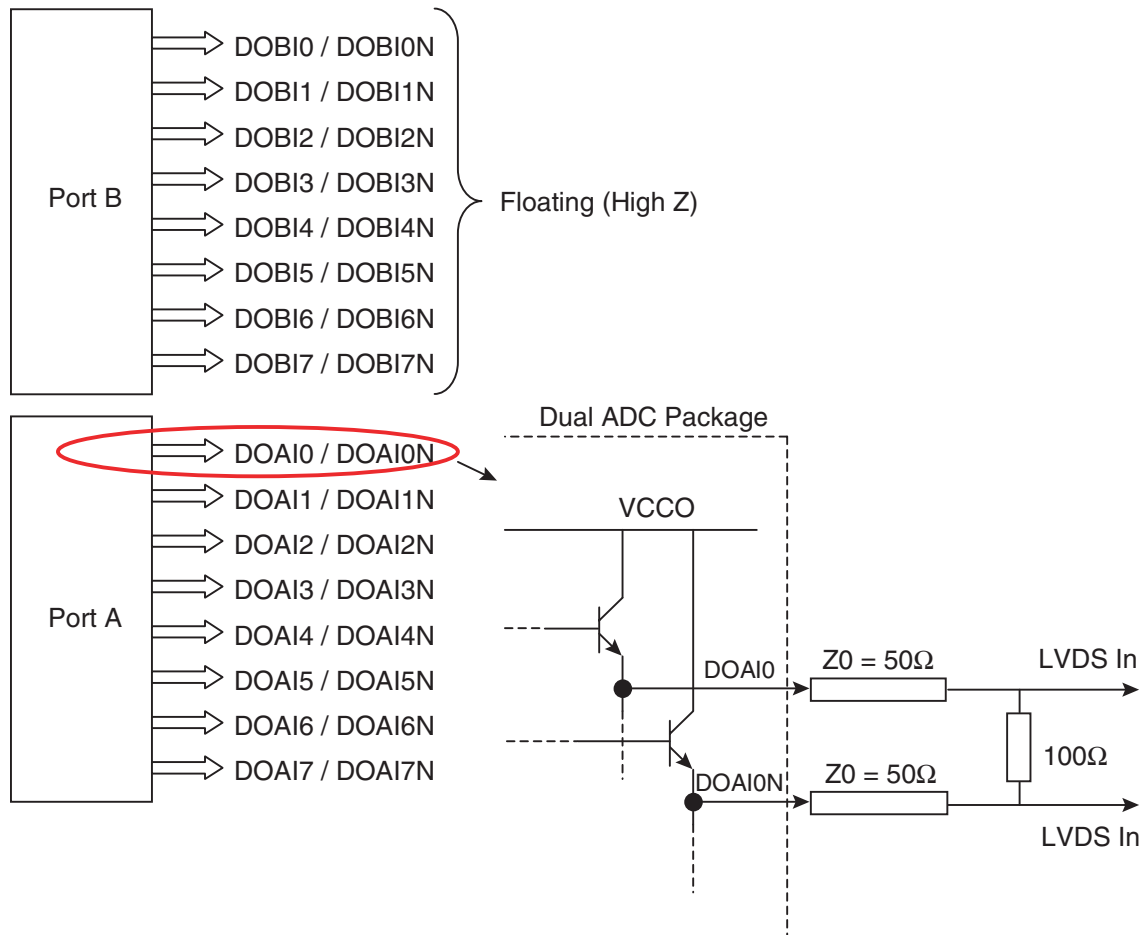

Note: If the outputs are to be used in single-ended mode, it is recommended that the true and false signals be terminated with a 50Ω resistor.

Using the Dual ADC With and ASIC/FPGA Load

Figure 56 on page 53 illustrates the configuration of the dual ADC (1:2 DMUX mode, independent I and Q clocks) driving an LVDS system (ASIC/FPGA) with potential additional DMUXes used to halve the speed of the dual ADC outputs.

Figure 56. Dual ADC and ASIC/FPGA Load Block Diagram

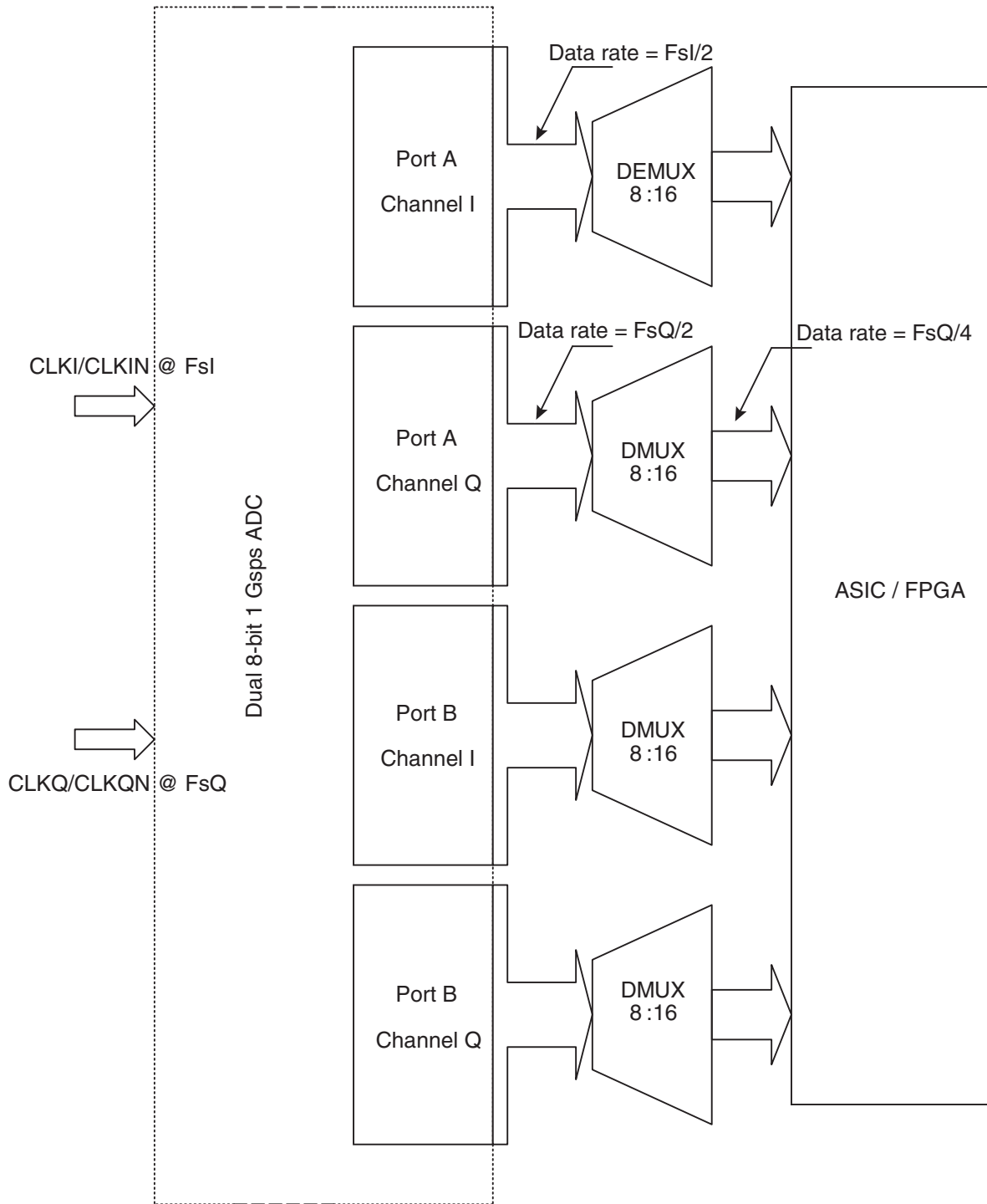

Note: The demultiplexers may be internal to the ASIC/FPGA system.

Thermal Characteristics

Simplified Thermal Model for LQFP 144 20 x 20 x 1.4 mm

The following model has been extracted from the ANSYS FEM simulations.

Assumptions: no air, no convection and no board.

Figure 57. Simplified Thermal Model for LQFP Package

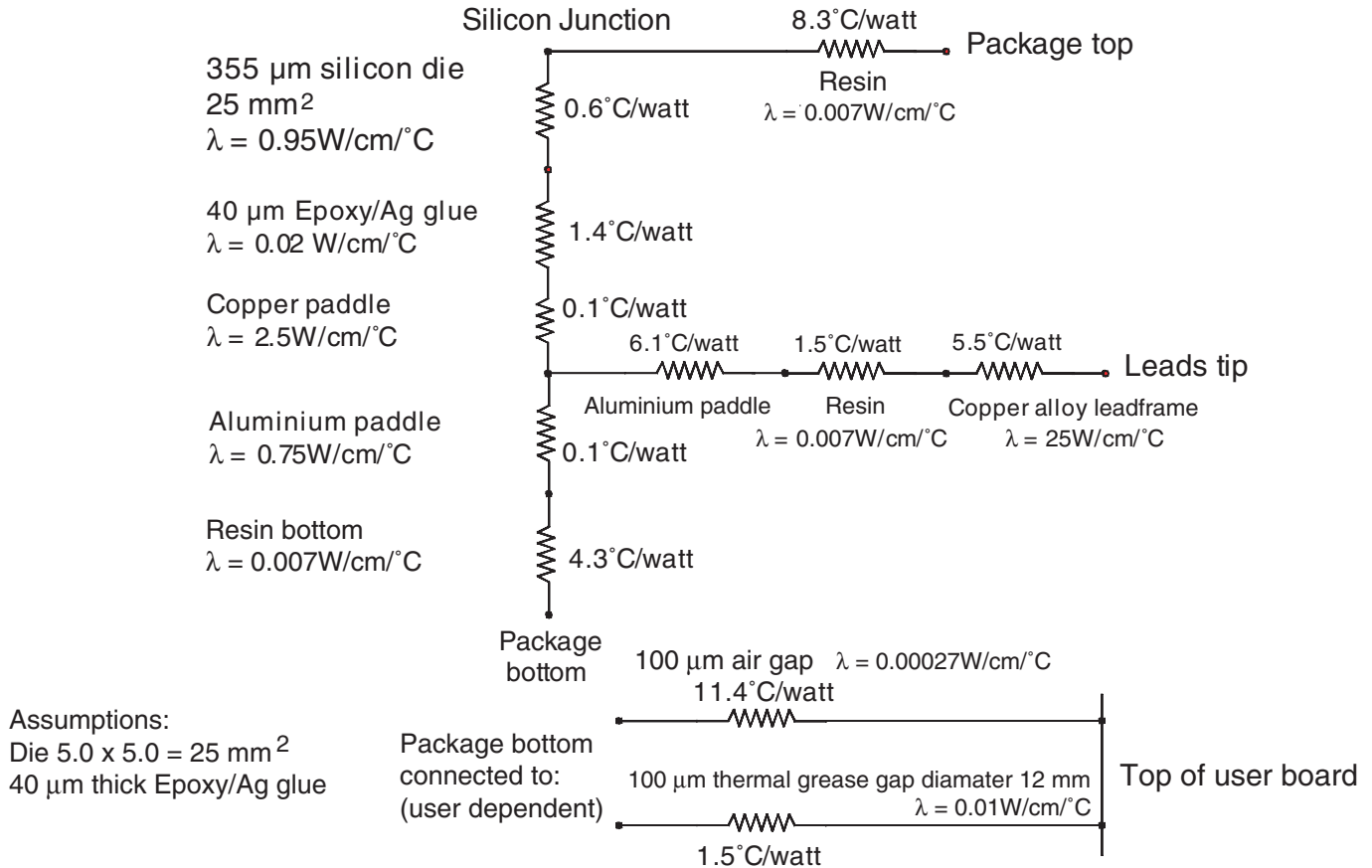

Note: The above are typical values with an assumption of uniform power dissipation over 2.5 x 2.5 mm² of the top surface of the die.

Thermal Resistance from Junction to Bottom of Leads

Assumptions: no air, no convection and no board.

The thermal resistance from the junction to the bottom of the leads is 15.2°C/W typical.

Thermal Resistance from Junction to Top of Case

Assumptions: no air, no convection and no board.

The thermal resistance from the junction to the top of the case is 8.3°C/W typical.

Thermal Resistance from Junction to Bottom of Case

Assumptions: no air, no convection and no board.

The thermal resistance from the junction to the bottom of the case is 6.4°C/W typical.

Thermal Resistance from Junction to Bottom of Air Gap

The thermal resistance from the junction to the bottom of the air gap (bottom of package) is 17.9°C/W typical.

Thermal Resistance from Junction to Ambient

The thermal resistance from the junction to ambient is 25.2° C/W typical.

Note: In order to keep the ambient temperature of the die within the specified limits of the device grade (that is T_A max = 70°C in commercial grade and 85°C in industrial grade) and the die junction temperature below the maximum allowed junction temperature of 105°C, it is necessary to operate the dual ADC in air flow conditions (1m/s recommended).

In still air conditions, the junction temperature is indeed greater than the maximum allowed T_J .

- $T_J = 25.2^\circ\text{C/W} \times 1.4\text{W} + T_A = 35.28 + 70 = 105.28^\circ\text{C}$ for commercial grade devices
- $T_J = 25.2^\circ\text{C/W} \times 1.4\text{W} + T_A = 35.28 + 85 = 125.28^\circ\text{C}$ for industrial grade devices

Thermal Resistance from Junction to Board

The thermal resistance from the junction to the board is 13° C/W typical.



Ordering Information

Part Number	Package	Temperature Range	Screening	Comments
AT84XAD004TD	LQFP 144	Ambient	Prototype	Prototype version Please contact your local Atmel sales office
AT84AD004CTD	LQFP 144	C grade $0^{\circ}\text{C} < \text{TA} < 70^{\circ}\text{C}$	Standard	
AT84AD004VTD	LQFP 144	V grade $-40^{\circ}\text{C} < \text{TA} < 85^{\circ}\text{C}$	Standard	
AT84AD004TD-EB	LQFP 144	Ambient	Prototype	Evaluation kit

Packaging Information

Figure 58. Package Type

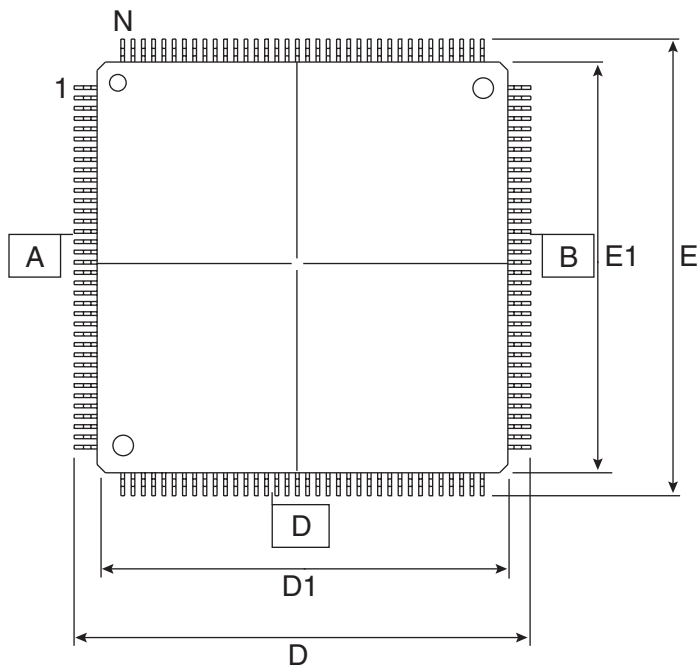

Body +2.00 mm footprint			
Dims.	Tols.	Leads	144L
A	max.		1.60
A1			0.05 min./0.15 max.
A2	+/- 0.05		1.40
D	+/-0.20		22.00
D1	+/-0.10		20.00
E	+/-0.20		22.00
E1	+/-0.10		20.00
L	+0.15/-0.10		0.60
e	basic		0.50
b	+/-0.05		0.22
ddd			0.08
ccc	max.		0.08
o			0°- 5°

- Notes:
1. All dimensions are in millimeters
 2. Dimensions shown are nominal with tolerances as indicated
 3. L/F: efect 64T copper or equivalent
 4. Foot length: "L" is measured at gauge plane at 0.25 mm above the seating plane

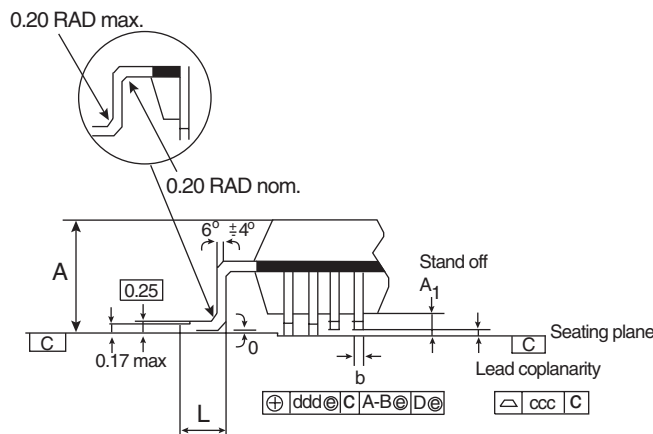
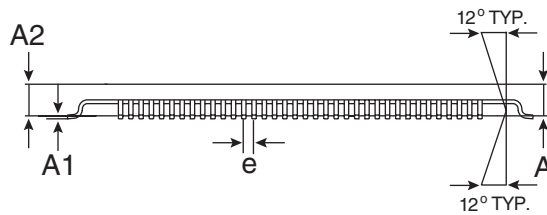

Note: Thermally enhanced package: LQFP 144, 20 x 20 x 1.4 mm.



Atmel Corporation

2325 Orchard Parkway
San Jose, CA 95131, USA
Tel: 1(408) 441-0311
Fax: 1(408) 487-2600

Regional Headquarters

Europe

Atmel Sarl
Route des Arsenalux 41
Case Postale 80
CH-1705 Fribourg
Switzerland
Tel: (41) 26-426-5555
Fax: (41) 26-426-5500

Asia

Room 1219
Chinachem Golden Plaza
77 Mody Road Tsimshatsui
East Kowloon
Hong Kong
Tel: (852) 2721-9778
Fax: (852) 2722-1369

Japan

9F, Tonetsu Shinkawa Bldg.
1-24-8 Shinkawa
Chuo-ku, Tokyo 104-0033
Japan
Tel: (81) 3-3523-3551
Fax: (81) 3-3523-7581

Atmel Operations

Memory

2325 Orchard Parkway
San Jose, CA 95131, USA
Tel: 1(408) 441-0311
Fax: 1(408) 436-4314

Microcontrollers

2325 Orchard Parkway
San Jose, CA 95131, USA
Tel: 1(408) 441-0311
Fax: 1(408) 436-4314

La Chantrerie
BP 70602
44306 Nantes Cedex 3, France
Tel: (33) 2-40-18-18-18
Fax: (33) 2-40-18-19-60

ASIC/ASSP/Smart Cards

Zone Industrielle
13106 Rousset Cedex, France
Tel: (33) 4-42-53-60-00
Fax: (33) 4-42-53-60-01

1150 East Cheyenne Mtn. Blvd.
Colorado Springs, CO 80906, USA
Tel: 1(719) 576-3300
Fax: 1(719) 540-1759

Scottish Enterprise Technology Park
Maxwell Building
East Kilbride G75 0QR, Scotland
Tel: (44) 1355-803-000
Fax: (44) 1355-242-743

RF/Automotive

Theresienstrasse 2
Postfach 3535
74025 Heilbronn, Germany
Tel: (49) 71-31-67-0
Fax: (49) 71-31-67-2340

1150 East Cheyenne Mtn. Blvd.
Colorado Springs, CO 80906, USA
Tel: 1(719) 576-3300
Fax: 1(719) 540-1759

Biometrics/Imaging/Hi-Rel MPU/ High Speed Converters/RF Datacom

Avenue de Rochepleine
BP 123
38521 Saint-Egreve Cedex, France
Tel: (33) 4-76-58-30-00
Fax: (33) 4-76-58-34-80

Literature Requests

www.atmel.com/literature

Disclaimer: Atmel Corporation makes no warranty for the use of its products, other than those expressly contained in the Company's standard warranty which is detailed in Atmel's Terms and Conditions located on the Company's web site. The Company assumes no responsibility for any errors which may appear in this document, reserves the right to change devices or specifications detailed herein at any time without notice, and does not make any commitment to update the information contained herein. No licenses to patents or other intellectual property of Atmel are granted by the Company in connection with the sale of Atmel products, expressly or by implication. Atmel's products are not authorized for use as critical components in life support devices or systems.

© Atmel Corporation 2004. All rights reserved. Atmel® and combinations thereof are the registered trademarks of Atmel Corporation or its subsidiaries. Other terms and product names may be the trademarks of others.



Printed on recycled paper.