



4180/4182 10/12-Bit Hybrid A/D Converter With Tri-State Latches

The 4180 and 4182 are 10/12-bit high-speed hybrid A/D converters having latched tri-state outputs. This latched output feature enables the designer to produce accurate and fast computer and microprocessor systems.

These hybrid units are fully self-contained in a 32-pin hermetically-sealed DIP including an internal precision reference and clock circuitry. Each unit is available in three versions as shown in Table 1.

Model	Temperature Range
4180/4182	0°C to +70°C
4180-80/4182-80	-55°C to +125°C
4180-83/4182-83	-55°C to +125°C, processed to MIL-STD-883

Table 1.

FEATURES

- o Latched Tri-State Outputs
- o Nonlinearity $\pm 1/2$ LSB Max.
- o Guaranteed Monotonicity over Temperature
- o Fast Conversion Time (4 to 6 μ s)
- o Hermetically Sealed 32-Pin DIP
- o Five Input Voltage Ranges

APPLICATIONS

- o Microprocessor Controlled Data Acquisition Systems
- o High Speed/High Accuracy Systems
- o High Reliability Industrial Equipment
- o Medical Instrumentation
- o Military Systems

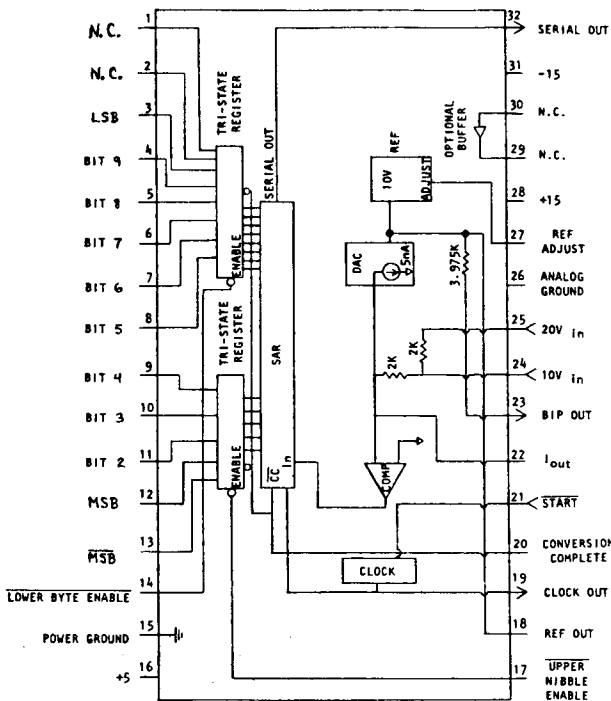

4180 FUNCTIONAL PINOUT

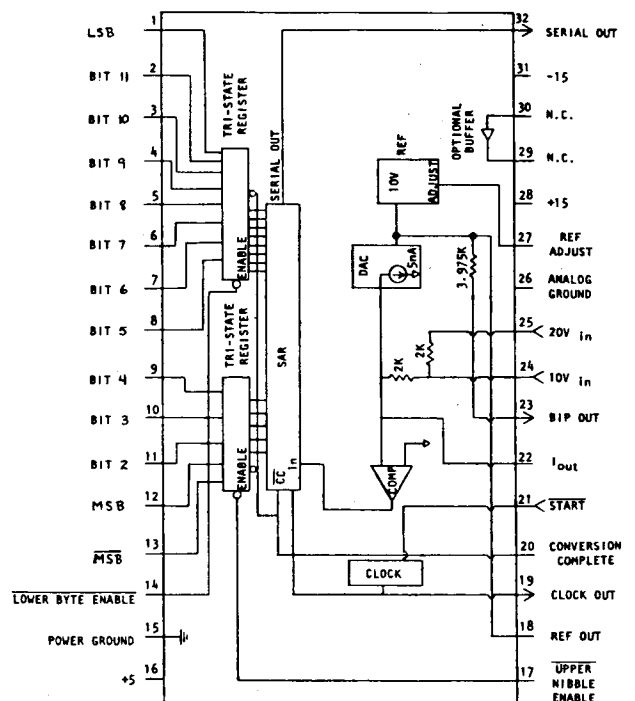

4182 FUNCTIONAL PINOUT

Figure 1.

SPECIFICATIONS

4180/4182

Specifications are tested at +25°C, ±15 V and +5 V, unless otherwise indicated.

	4180		4182	
	Typ.	Guar.	Typ.	Guar.
RESOLUTION	10 Bits		12 Bits	

INPUTS

Analog Input/Impedance	+5V/2KΩ, +10V/2KΩ, +10V/4KΩ, ±2.5V/1KΩ, +5V/1KΩ		
Power	+15V @ 30mA -15V @ 30mA +5V @ 138mA		
Digital			
Start Convert			
Initiation	"1" to "0"		
Pulse width Min.	50 ns		
Enable Control			
"0" State	Parallel Outputs Enabled		

TRANSFER CHARACTERISTICS

Accuracy			
Nonlinearity Max.	+1/2 LSB		
Differential Nonlinearity Max.	±1/2 LSB		
Monotonicity	Over the operating temp. range		
Zero Offset Error (adj. to zero)			
Unipolar	+0.05%		
Bipolar	±0.1%		
Gain Error (adj. to zero)	±0.1% FS		
Stability			
Gain Error T.C.	+30 PPM/°C		
Offset Error T.C.	±10 PPM/°C		
Dynamic Characteristics			
Conversion Time	4 μs	6 μs	6 μs 8 μs

OUTPUTS

Reference			
Voltage	10 V		
Current	5 mA		
Digital			
Logic Codes			
Parallel, Unipolar	Binary		
Parallel, Bipolar	Offset Binary		
Output Drive	2TTL Loads		
Serial Data, Unipolar	Binary		
, Bipolar	Offset Binary		
Output Drive	4TTL Loads		
Switching Levels, all digital outputs			
"0" State	< 0.4V		
"1" State	> 2.4V		
Status			
"0" State	During Conversion		
Output Drive	4TTL Loads		
Clock Output			
Output Drive	8TTL Loads		
Frequency	Variable = 600 ns to 300 ns		
Logic	Positive TTL		

ENVIRONMENTAL SPECIFICATIONS

Operating Temp. Range 4180/4182	0°C to +70°C
4180-80/83; 4182-80/83	-50°C to +125°C
Storage Temp. Range	-65°C to +150°C

ABSOLUTE MAXIMUM RATINGS

Supply Voltage to Ground	
+15V	+18V
±5V	±7V
Digital Input Voltage	Digital Supply
Analog Input Voltage	Analog Supply

REPRESENTATIVE
TELEPHONE 408-257-8333



Allied Drive at Route 128, Dedham, Massachusetts 02026
Tel: (617)329-1600 TWX:(710)348-6726 Telex: 92-4439

Preliminary, Printed 5/80

Teledyne Philbrick makes no representation that use of its modules in the circuits described herein, or use of other technical information contained herein will not infringe on existing or future patent rights nor do the descriptions contained herein imply the granting of licenses to make, use, or sell equipment constructed in accordance therewith.