

### 4-Bit Arithmetic Logic Unit

The DV74LS181 and DV74ALS181 are 4-bit high speed parallel Arithmetic Logic Units (ALU). Controlled by the 4 Function Select Input (S<sub>0</sub>...S<sub>3</sub>) and the Mode control Input (M), each can perform all the 16 possible logic operations or 16 different arithmetic operations on active HIGH or active LOW operands. The Truth Table lists these operations. When the Mode Control Input (M) is HIGH, all internal carries are inhibited and the device performs logic operations on the individual bits as listed. When M is LOW, the carries are enabled and the device performs arithmetic operations on the two 4-bit words. The device uses full internal carry lookahead and provides for either ripple carry between devices using the C<sub>n+4</sub> output, or for carry in. When speed requirements are not stringent, the LS or ALS 181 can be used in a simple carry mode by connecting the Carry Output (C<sub>n+4</sub>).

The A=B output goes HIGH when all four  $\bar{F}$  outputs are HIGH and can be used to indicate logic equivalence over 4 bits when the unit is in the subtract mode. The A=B output is open collector and can be wired-AND with other A=B outputs to give a comparison for more than 4 bits. The A=B signal can also be used with the C<sub>n+4</sub> signal to indicate A>B and A<B.

The Truth Table lists the arithmetic operations that are performed without a carry in. An incoming carry adds a one to each operation. Thus, select code LHHH generates A minus B minus 1 (2s complement notation) without a carry in and generates A minus B when a carry in is applied. Because subtraction is actually performed by complementary addition (1s complement), a carry out means borrow; thus a carry is generated when there is underflow.

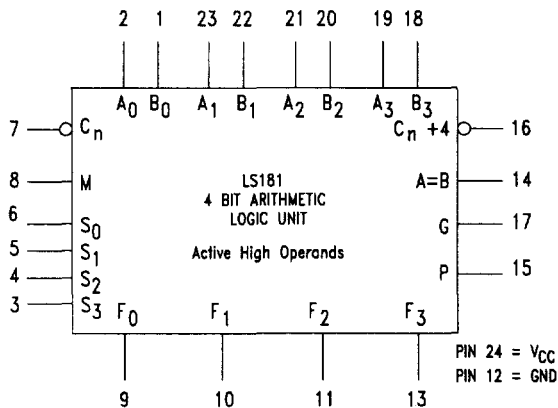
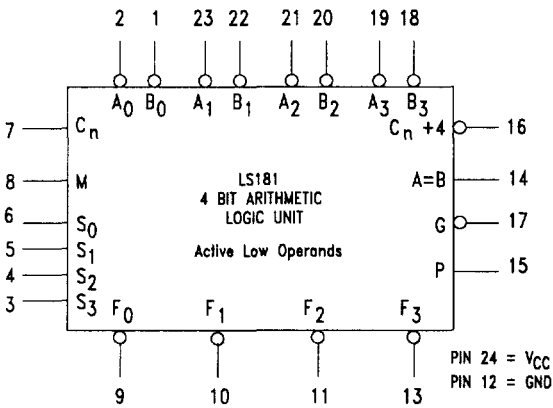
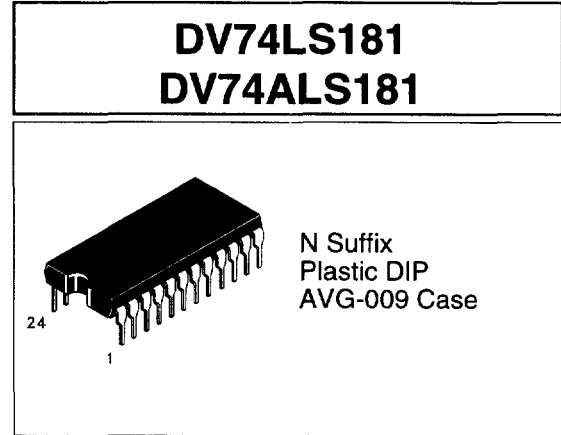

#### PIN ASSIGNMENT

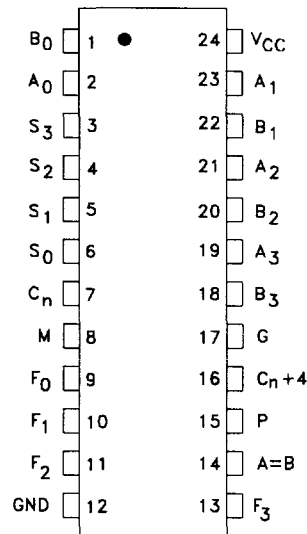

#### PIN NAMES

- A<sub>0</sub>-A<sub>3</sub>, Operand A (Active LOW) Inputs
- B<sub>0</sub>-B<sub>3</sub>, Operand B (Active LOW) Inputs
- S<sub>0</sub>-S<sub>3</sub>, Function - Select Inputs
- M, Mode Control Input
- C<sub>n</sub>, Carry Input
- F<sub>0</sub>-F<sub>3</sub>, Function (Active LOW) Output
- $\bar{A} = \bar{B}$ , Comparator Output
- $\bar{G}$ , Carry Generator (Active LOW) Output
- $\bar{P}$ , Carry Propagate (Active LOW) Output
- C<sub>n+4</sub>, Carry Output

**ABSOLUTE MAXIMUM RATINGS**

Symbol	Parameter	LS181	ALS181	Unit
V <sub>CC</sub>	Supply Voltage	7.0	7.0	V
V <sub>IN</sub>	Input Voltage	7.0	7.0	V
T <sub>STG</sub>	Storage Temperature Range	-65 to +150	-65 to +150	°C

**GUARANTEED OPERATING CONDITIONS**

Symbol	Parameter	LS181		ALS181		Unit
		Min	Max	Min	Max	
V <sub>CC</sub>	Supply Voltage	4.5	5.5	4.5	5.5	V
V <sub>OH</sub>	High Level Output Voltage		5.5		5.5	V
V <sub>IH</sub>	High Level Input Voltage	2.0		2.0		V
V <sub>IL</sub>	Low Level Input Voltage		0.8		0.8	V
I <sub>OL</sub>	Low Level Output Current		8.0		8.0	mA
T <sub>A</sub>	Ambient Temperature Range	-10 to +70		-10 to +70		°C

**DC ELECTRICAL CHARACTERISTICS** over full operating conditions

Symbol	Parameter		Conditions	LS181			ALS181			Unit
				Min	Typ	Max	Min	Typ	Max	
V <sub>IK</sub>	Input Clamp Voltage		V <sub>CC</sub> =min; I <sub>IN</sub> = -18 mA			-1.5		-0.65	-1.5	V
V <sub>OH</sub>	High Level Output Voltage		V <sub>CC</sub> =min; I <sub>OH</sub> = -0.4mA	V <sub>CC</sub> -2	3.5		V <sub>CC</sub> -2			V
V <sub>OL</sub>	Low Level Output Voltage		V <sub>CC</sub> =min; I <sub>OL</sub> =4.0mA		0.25	0.4		0.25	0.4	V
			V <sub>CC</sub> =min; I <sub>OL</sub> =8.0mA		0.35	0.5		0.35	0.5	
			V <sub>CC</sub> =min; I <sub>OL</sub> =16mA			0.7			0.7	
			V <sub>CC</sub> =min; I <sub>OL</sub> =8.0mA			0.5			0.5	
I <sub>IH</sub>	High Level Input Current	Mode Input Any A or B Input Any S Input C <sub>n</sub> Input	V <sub>CC</sub> =max, V <sub>IH</sub> =2.7V			20			20	μA
						60			60	
			V <sub>CC</sub> =max, V <sub>IH</sub> = 7.0V			0.1			0.1	mA
					0.3			0.3		
					0.4			0.4		
					0.5			0.5		
I <sub>IL</sub>	Low Level Input Current	Mode Input Any A or B Input Any S Input C <sub>n</sub> Input	V <sub>CC</sub> =max, V <sub>IN</sub> =0.4V			-0.4			-0.2	mA
						-1.2			-0.6	
						-1.6			-0.8	
						-2.0			-1.0	
I <sub>O</sub>	Short Circuit Current		V <sub>CC</sub> =max, V <sub>O</sub> =2.25V	-20		-110	-30		-112	mA
I <sub>CC</sub>	Supply Current	S0 through S3, M, and A at 4.5V	V <sub>CC</sub> =max Other Inputs Grounded			34			28	mA
		S0 through S3, and M at 4.5V				37			30	

**SWITCHING CHARACTERISTICS**

Symbol	Parameter	Conditions	LS181		ALS181		Unit
			Min	Max	Min	Max	
t <sub>PLH</sub>	Propagation Delay, (C <sub>n</sub> to C <sub>n+4</sub> )	M=0V (Sum or Diff Mode)		27		18	ns
t <sub>PHL</sub>				20		12	

Symbol	Parameter	Conditions	LS181		ALS181		Unit
			Min	Max	Min	Max	
tPLH	(C <sub>n</sub> to $\bar{F}$ Outputs)	M=0V, (Sum Mode)		26		18	ns
tPHL				20		12	
tPLH	$(\bar{A}$ or $\bar{B}$ Inputs to $\bar{G}$ Output)	M=S <sub>1</sub> =S <sub>2</sub> =0V, S <sub>0</sub> =S <sub>3</sub> =4.5V (Sum Mode)		29		20	ns
tPHL				23		15	
tPLH	$(\bar{A}$ or $\bar{B}$ Inputs to $\bar{G}$ Output)	M=S <sub>0</sub> =S <sub>3</sub> =0V, S <sub>1</sub> =S <sub>2</sub> =4.5V (Diff Mode)		32		20	ns
tPHL				32		20	
tPLH	$(\bar{A}$ or $\bar{B}$ Inputs to $\bar{P}$ Output)	M=S <sub>1</sub> =S <sub>2</sub> =0V, S <sub>0</sub> =S <sub>3</sub> =4.5V (Sum Mode)		30		18	ns
tPHL				30		18	
tPLH	$(\bar{A}$ or $\bar{B}$ Inputs to $\bar{P}$ Output)	M=S <sub>0</sub> =S <sub>3</sub> =0V, S <sub>1</sub> =S <sub>2</sub> =4.5V (Diff Mode)		30		18	ns
tPHL				33		20	
tPLH	$(\bar{A}$ or $\bar{B}$ Inputs to $\bar{F}$ Output)	M=S <sub>1</sub> =S <sub>2</sub> =0V, S <sub>0</sub> =S <sub>3</sub> =4.5V (Sum Mode)		32		20	ns
tPHL				20		12	
tPLH	$(\bar{A}$ or $\bar{B}$ Inputs to $\bar{F}$ Output)	M=S <sub>0</sub> =S <sub>3</sub> =0V, S <sub>1</sub> =S <sub>2</sub> =4.5V (Diff Mode)		32		20	ns
tPHL				32		20	
tPLH	$(\bar{A}$ or $\bar{B}$ Inputs to $\bar{F}$ Output)	M=4.5V (Logic Mode)		33		20	ns
tPHL				38		25	
tPLH	$(\bar{A}$ or $\bar{B}$ Inputs to C <sub>n+4</sub> Output)	M=0V, S <sub>0</sub> =S <sub>3</sub> =4.5V, S <sub>1</sub> =S <sub>2</sub> =0V (Sum Mode)		38		25	ns
tPHL				38		25	
tPLH	$(\bar{A}$ or $\bar{B}$ Inputs to C <sub>n+4</sub> Output)	M=0V, S <sub>0</sub> =S <sub>3</sub> =0V, S <sub>1</sub> =S <sub>2</sub> =4.5V (Diff Mode)		41		28	ns
tPHL				41		28	
tPLH	$(\bar{A}$ or $\bar{B}$ Inputs to A=B Output)	M=S <sub>0</sub> =S <sub>3</sub> =0V, S <sub>1</sub> =S <sub>2</sub> =4.5V R <sub>L</sub> =2.0k $\Omega$ , (Diff Mode)		50		35	ns
tPHL				62		40	

**TRUTH TABLE**

MODE SELECT INPUTS				ACTIVE LOW INPUTS & OUTPUTS		ACTIVE HIGH INPUTS & INPUTS	
S <sub>3</sub>	S <sub>2</sub>	S <sub>1</sub>	S <sub>0</sub>	LOGIC (M=H)	ARITHMETIC** (M=L) (C <sub>n</sub> =L)	LOGIC (M=H)	ARITHMETIC** (M=L) (C <sub>n</sub> =H)
L	L	L	L	$\bar{A}$	A minus 1	$\bar{A}$	A
L	L	L	H	$\bar{A}\bar{B}$	AB minus 1	$\bar{A}+\bar{B}$	A+B
L	L	H	L	$\overline{A+B}$	$\bar{A}\bar{B}$ minus 1	$\bar{A}\bar{B}$	$\overline{A+B}$
L	L	H	H	Logical 1	minus 1	Logical 0	minus 1
L	H	L	L	$\overline{A+B}$	A plus ( $\overline{A+B}$ )	$\bar{A}\bar{B}$	A plus AB
L	H	L	H	$\bar{B}$	AB plus ( $\bar{B}$ )	$\bar{B}$	(A+B) plus AB
L	H	H	L	$\overline{A\oplus B}$	A minus B minus 1	$A\oplus B$	A minus B minus 1
L	H	H	H	$\overline{A+B}$	A+B	$\bar{A}\bar{B}$	AB minus 1
H	L	L	L	$\bar{A}\bar{B}$	A plus (A+B)	$\bar{A}+\bar{B}$	A plus AB
H	L	L	H	$A\oplus B$	A plus B	$\overline{A\oplus B}$	A plus B
H	L	H	L	B	$\bar{A}\bar{B}$ plus (A+B)	B	( $\overline{A+B}$ ) plus AB
H	L	H	H	A+B	A+B	AB	AB minus 1
H	H	L	L	Logical 0	A plus A*	Logical 1	A plus A*
H	H	L	H	$\bar{A}\bar{B}$	$\bar{A}\bar{B}$ plus A	$\bar{A}+\bar{B}$	(A+B) plus A
H	H	H	L	AB	$\bar{A}\bar{B}$ plus A	A+B	( $\overline{A+B}$ ) plus A
H	H	H	H	A	A	A	A minus 1

L=LOW Voltage Level  
H=HIGH Voltage Level

\* Each bit is shifted to the next more significant position

\*\* Arithmetic operations expressed in 2s complement notation

**SWITCHING WAVEFORMS**

