

Product Document

Color Sensors Light-to-Digital

www.ams.com/TCS3400



TCS3400 - Color Sensor Family

- RGB color light sensing enables accurate color sensing for ambient light and color temperature measurements
- Additional clear and infrared reference channels enable IR light measurement for light-source detection
- Circular segmented photo-diodes provides an equal response to 360° incident light

We provide innovative analog solutions to the most challenging applications in sensor and sensor interfaces, power management, and wireless.

General Description

The TCS3400 device provides color and IR (red, green, blue, clear and IR) light sensing. The color sensing provides for improved accuracy lux and color temperature measurements typically used to adjust the backlight intensity and correct the display color gamut. Additionally it can be used for light source type detection as it reports the IR content of the light.

The TCS3400 device provides ambient light sensing and color temperature sensing. The internal state machine manages the operation of the device. It controls the ALS functionality and power down modes. Average power consumption is managed via control of variable endurance low power wait cycles. The interrupt feature improves system efficiency by eliminating the need to poll the sensor. Three interrupt sources (ALS, ALS saturation) can activate the open drain output pin. Each interrupt source is

enabled independently. ALS interrupts appear when upper or lower thresholds are exceeded for a consecutive number of sample readings. The advanced digital color light sensor portion of the TCS3400 contains a segmented circular photodiode array used for color measurements. This architecture provides stable color sensing independent of the incident angle of light. Four integrating analog-to-digital converters (ADCs) integrate light energy from photodiodes simultaneously.

The advanced digital color light sensor portion of the TCS3400 contains a segmented circular photodiode array used for color measurements. This architecture provides stable color sensing independent of the incident angle of light. Four integrating analog-to-digital converters (ADCs) integrate light energy from photodiodes simultaneously.

Applications

- Light color temperature measurement and control
- Lux ambient light sensing for display brightness control
- Light source identification in for camera lens shading
- Improved automatic white balance applications

Ordering Code	Address	Interface	Delivery Form
TCS34001FN*	0x39	I ² C V _{BUS} = V _{DD} Interface	FN-6
TCS34003FN	0x39	I ² C Bus = 1.8V Interface	FN-6
TCS34005FN*	0x29	I ² C V _{BUS} = V _{DD} Interface	FN-6
TCS34007FN	0x29	I ² C Bus = 1.8V Interface	FN-6

* Contact ams for availability

Features

- RGBC and ALS support
- Circular segmented RGBC photodiode
- RGBC with Infrared sensor
- Color light temperature sensing and ambient light sensing
 - 1M:1 dynamic range
 - very high sensitivity
 - programmable analog gain and integration time
- Power management
 - 65 μ A typical current
 - programmable wait timer
- I²C fast-mode compatible interface
 - 400 kbits/s data rate
 - V_{DD} or 1.8-V Bus interface
- 2 mm x 2.4 mm dual flat no-lead (OLN) package

TCS3400 Block Diagram

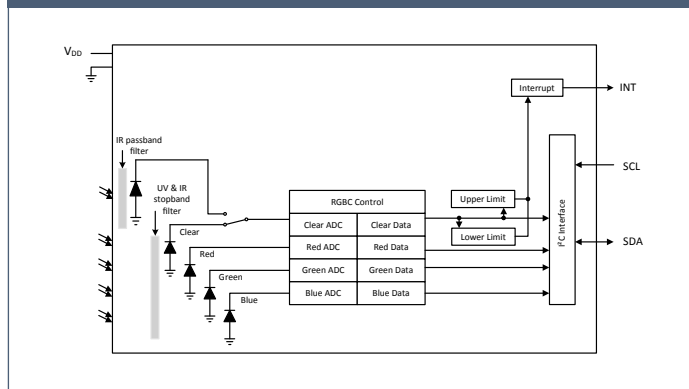

TCS3400 Spectral Responsivity

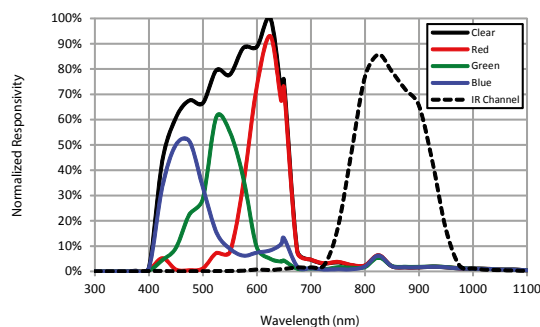

www.ams.com
 products@ams.com
 © 03/2016 by ams
 Subject to change without notice

AMS-TAOS USA Inc.
 5556 Tennyson Pkwy
 Plano, TX 75024, USA
 Phone: +1 972 673 0759

Sales Offices Worldwide
 sales-europe@ams.com
 sales-asia@ams.com
 sales-americas@ams.com