

HDSP-2351, HDSP-2352, HDSP-2353

Extended Temperature Four Character 5.0 mm (0.20 Inch) 5 x 7 Alphanumeric Display for Sunlight Viewable Applications

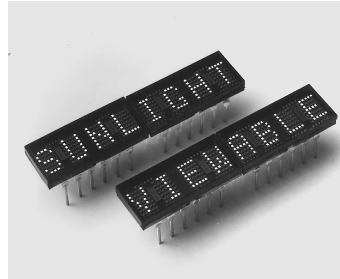

Data Sheet



Description

The HDSP-2351/2352/2353 displays are designed for use in military applications requiring readability in bright sunlight. With a proper contrast enhancement filter and heat sinking, these displays are readable in sunlight ambients up to 10,000 footcandles. The character font is a 5.0 mm (0.20 inch) 5 x 7 LED array for displaying alphanumeric information. These devices are available in yellow, high efficiency red, and high performance green. Each four character cluster is packaged in a 12-pin dual-in-line package. An on-board serial-in-parallel-out 7-bit shift register associated with each digit controls constant current LED row drivers. Full character display is achieved by external column strobing.

Features

- Sunlight viewable up to 10,000 footcandles
- Wide operating temperature range -55°C to +85°C
- Compact ceramic package
- Wide viewing angle
- End and row stackable
- 5 x 7 LED matrix displays full ASCII set
- Integrated shift registers with constant current LED drivers
- TTL compatible
- Categorized for luminous intensity
- HDSP-2351/2353 categorized for color

Applications

- Military avionics — cockpit displays, aircraft system monitors, fuel management and airborne navigational radio systems
- Military test and ground support field equipment
- Military vehicles and equipment
- Other applications requiring readability in direct sunlight

Devices

Yellow	High Efficiency Red	High Performance Green
HDSP-2351	HDSP-2352	HDSP-2353

Package Dimensions

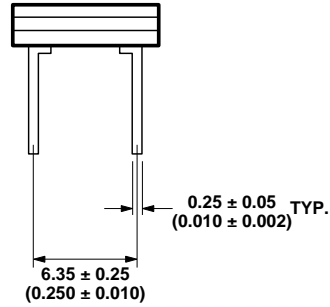
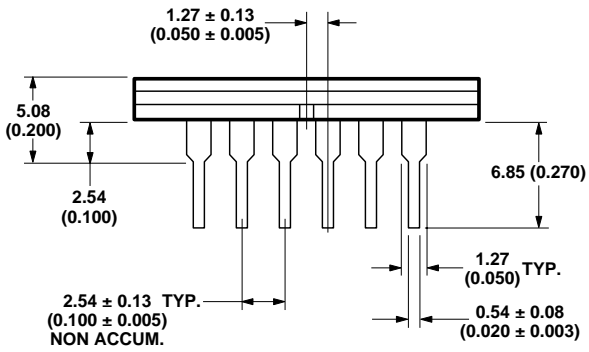
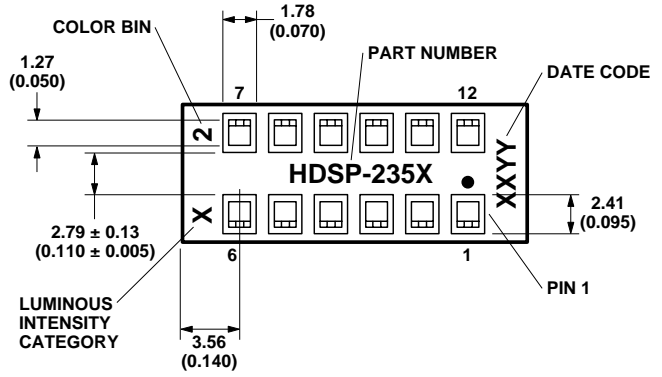
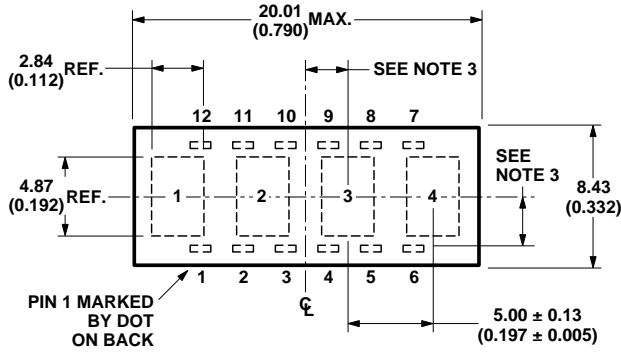

PIN	FUNCTION	PIN	FUNCTION
1	COLUMN 1	7	DATA OUT
2	COLUMN 2	8	V _B
3	COLUMN 3	9	V _{CC}
4	COLUMN 4	10	CLOCK
5	COLUMN 5	11	GROUND
6	INT. CONNECT*	12	DATA IN

*DO NOT CONNECT OR USE

NOTES:

1. DIMENSIONS IN MILLIMETERS (INCHES).
2. UNLESS OTHERWISE SPECIFIED, THE TOLERANCE ON ALL DIMENSIONS IS ± 0.38 mm (± 0.15 ").
3. CHARACTERS ARE CENTERED WITH RESPECT TO LEADS WITHIN ± 0.13 mm (± 0.005 ").
4. LEAD MATERIAL IS GOLD PLATED COPPER ALLOY.

Recommended Operating Conditions over Operating Temperature Range (-55°C to +85°C)

Parameter	Symbol	Min.	Nom.	Max.	Units	Fig.
Supply Voltage	V _{CC}	4.75	5.0	5.25	V	
Data Out Current, Low State	I _{OL}			1.6	mA	
Data Out Current, High State	I _{OH}			-0.5	mA	
Column Input Voltage, Column On HDSP-2381/2382/2383	V _{COL}	2.75		3.5	V	4
Setup Time	t _{SETUP}	70	45		ns	1
Hold Time	t _{HOLD}	30	0		ns	1
Width of Clock	t _{W(CLOCK)}	75			ns	1
Clock Frequency	f _{CLOCK}	0		3	MHz	1
Clock Transition Time	t _{THL}			200	ns	1
Free Air Operating Temperature Range ^[1,2]	T _A	-20		85	°C	3

Electrical Characteristics over Operating Temperature Range (-55°C to +85°C)

Description	Symbol	Test Conditions	Min.	Typ.*	Max.	Units	Fig.	
Supply Current	I _{CC}	V _{CC} = 5.25 V V _{CLOCK} = V _{DATA} = 2.4 V All SR Stages = Logical 1	V _B = 0.4 V		50	60	mA	
			V _B = 2.4 V		90	100	mA	
Column Input Current (any Column Pin)	I _{COL}	V _{CC} = 5.25 V V _{COL} = 3.5 V All SR Stages = Logical 1	V _B = 0.4 V			500	μA	4
Column Input Current (any Column Pin)	I _{COL}		V _B = 2.4 V		550	653	mA	
V _B , Clock or Data Input Threshold High	V _{IH}	V _{CC} = V _{COL} = 4.75 V		2.0			V	
V _B , Data Input Threshold Low	V _{IL}					0.8	V	
Clock Input Threshold Low	V _{IL}	V _{CC} = 4.75 V				0.6	V	
Input Current Logical 1	V _B , Clock	V _{CC} = 5.25 V, V _{IH} = 2.4 V			20	80	μA	
	Data In				10	40	μA	
Input Current Logical 0	V _B , Clock	V _{CC} = 5.25 V, V _{IL} = 0.4 V			-500	-800	μA	
	Data In				-250	-400	μA	
Data Out Voltage	V _{OH}	V _{CC} = 4.75 V, I _{OH} = -0.5 mA, I _{COL} = 0 mA			2.4	3.4	V	
	V _{OL}				0.2	0.4	V	
Power Dissipation Per Package**	P _D	V _{CC} = 5.0 V, V _{COL} = 3.5 V, 17.5% DF 15 LEDs on per character, V _B = 2.4 V		1.05			W	2
Thermal Resistance IC Junction-to-Pin	R _{θJ-PIN}			10			°C/W/Device	2
Leak Rate						5x10 ⁻⁸	cc/sec	

*All typical values specified at V_{CC} = 5.0 V and T_A = 25°C unless otherwise noted.

**Power dissipation per package with four characters illuminated.

Optical Characteristics

Yellow HDSP-2351

Description	Symbol	Test Conditions	Min.	Typ.*	Max.	Units	Fig.
Peak Luminous Intensity per LED ^[4,8] (Character Average)	$I_{V\text{PEAK}}$	$V_{CC} = 5.0\text{ V}$, $V_{COL} = 3.5\text{ V}$ $T_i = 25^\circ\text{C}$ ^[6] , $V_B = 2.4\text{ V}$	2400	3400		μcd	3
Dominant Wavelength ^[5,7]	λ_d			585		nm	
Peak Wavelength	λ_{PEAK}			583		nm	

High Efficiency Red HDSP-2352

Description	Symbol	Test Conditions	Min.	Typ.*	Max.	Units	Fig.
Peak Luminous Intensity per LED ^[4,8] (Character Average)	$I_{V\text{PEAK}}$	$V_{CC} = 5.0\text{ V}$, $V_{COL} = 3.5\text{ V}$ $T_i = 25^\circ\text{C}$ ^[6] , $V_B = 2.4\text{ V}$	1920	2850		μcd	3
Dominant Wavelength ^[7]	λ_d			626		nm	
Peak Wavelength	λ_{PEAK}			635		nm	

High Performance Green HDSP-2353

Description	Symbol	Test Conditions	Min.	Typ.*	Max.	Units	Fig.
Peak Luminous Intensity per LED ^[4,8] (Character Average)	$I_{V\text{PEAK}}$	$V_{CC} = 5.0\text{ V}$, $V_{COL} = 3.5\text{ V}$ $T_i = 25^\circ\text{C}$ ^[6] , $V_B = 2.4\text{ V}$	2400	3000		μcd	3
Dominant Wavelength ^[5,7]	λ_d			574		nm	
Peak Wavelength	λ_{PEAK}			568		nm	

*All typical values specified at $V_{CC} = 5.0\text{ V}$ and $T_A = 25^\circ\text{C}$ unless otherwise noted.

**Power dissipation per package with four characters illuminated.

Notes:

- The HDSP-2351/2352/2353 should be derated linearly above 50°C at $24.3\text{ mW}/^\circ\text{C}$, based on a device mounted such that the thermal resistance from IC junction to ambient is $45^\circ\text{C}/\text{W}$ ($10^\circ\text{C}/\text{W}$ $R_{\theta\text{J-PIN}}$ and $35^\circ\text{C}/\text{W}$ $R_{\text{PIN-A}}$). See Figure 2 for power deratings based on lower thermal resistance mounting.
- Operation above 50°C ambient is possible provided the following conditions are met. The junction temperature should not exceed 125°C (T_j) and the temperature at the pins should not exceed 100°C (T_C).
- Maximum allowable dissipation is derived from $V_{CC} = 5.25\text{ V}$, $V_B = 2.4\text{ V}$, $V_{COL} = 3.5\text{ V}$, 20 LEDs on per character, 20% DF.
- These LED displays are categorized for luminous intensity with the intensity category designated by a letter code on the bottom of the package.
- The HDSP-2351/2353 are categorized for color with the color category designated by a number code on the bottom of the package.
- T_i refers to the initial case temperature of the device immediately prior to the light measurement.
- Dominant wavelength λ_d , is derived from the CIE chromaticity diagram, and represents the single wavelength which defines the color of the device.
- The luminous sterance of the LED may be calculated using the following relationships:
 $L_V (\text{cd}/\text{m}^2) = I_V (\text{Candela})/\text{A} (\text{Metre})^2$
 $L_V (\text{Footlamberts}) = \pi I_V (\text{Candela})/\text{A} (\text{Foot})^2$
 $\text{A} = 5.3 \times 10^{-8} \text{M}^2 = 5.8 \times 10^{-7} (\text{Foot})^2$

Absolute Maximum Ratings

Supply Voltage V_{CC} to Ground -0.5 V to + 6.0 V
 Inputs, Data Out and V_B -0.5 V to V_{CC}
 Column Input Voltage, V_{COL} -0.5 V to + 6.0 V
 Free Air Operating Temperature
 Range, $T_A^{[1,2]}$ -55°C to +85°C
 Storage Temperature Range, T_S -55°C to +100°C
 Maximum Allowable Package Dissipation
 at $T_A = 25^\circ\text{C}^{[1,2,3]}$ 1.74 Watts
 Maximum Solder Temperature 1.59 mm (0.063 in.)
 Below Seating Plane $t < 5$ sec 260°C

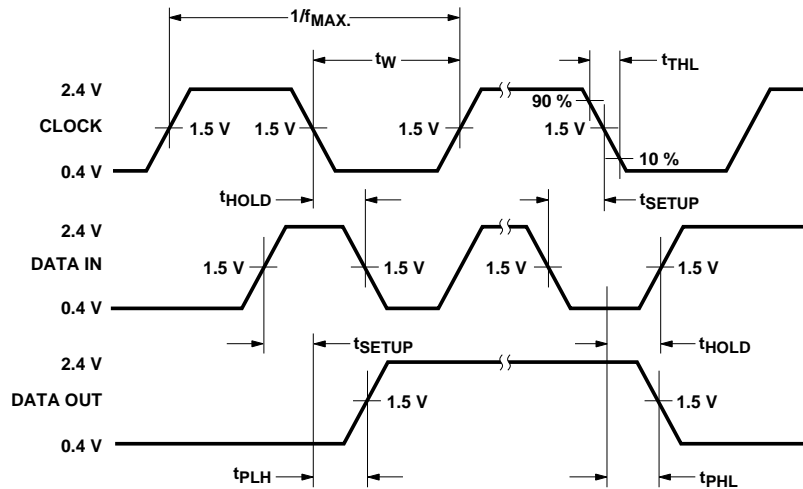

PARAMETER	CONDITION	MIN.	TYP.	MAX.	UNITS
f_{CLOCK} CLOCK RATE				3	MHz
t_{PLH} , t_{PHL} PROPAGATION DELAY CLOCK TO DATA OUT	$C_L = 15$ pF $R_L = 2.4$ K Ω			125	ns

Figure 1. Switching Characteristics ($T_A = -20^\circ\text{C}$ to $+85^\circ\text{C}$).

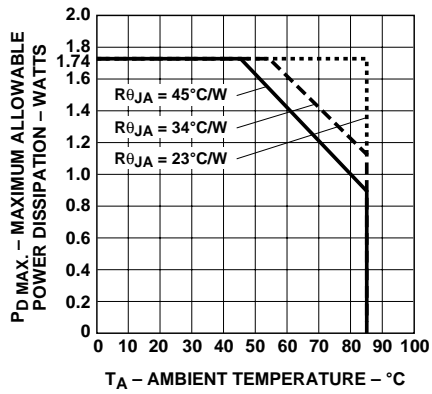

Figure 2. Maximum Allowable Power Dissipation vs. Ambient Temperature as a Function of Thermal Resistance IC Junction to Ambient Air. $R_{\theta JA}$.

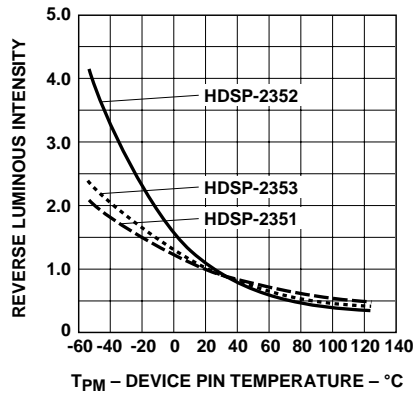

Figure 3. Relative Luminous Intensity vs. Device Substrate (PIN) Temperature.

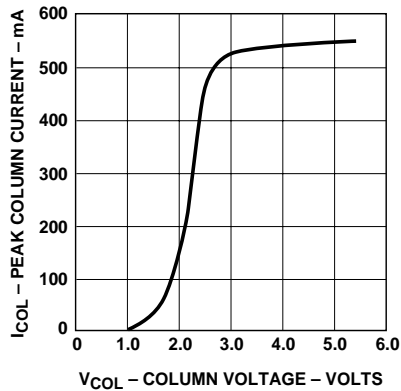

Figure 4. Peak Column Current vs. Column Voltage.

Electrical Description

The electrical configuration of the HDSP-235X series alphanumeric displays allows for an effective interface to a microprocessor data source. Each display device contains four 5x7 LED dot matrix characters and two integrated circuits, as diagrammed in Figure 5. The two integrated circuits, with TTL compatible inputs, form a 28 bit serial-in-parallel-out column data shift register. The data input is connected to shift register bit position 1 and the data output is connected to bit position 28. The shift register parallel outputs are connected to constant current sinking LED row drivers that sink a nominal 19.6 mA. A logic 1 stored in the shift register enables the corresponding LED row driver and a logic 0 stored in the shift register disables the corresponding LED row driver.

Column data is loaded into an on-board shift register with high to low transitions of the Clock input. To load character information into the display, column data for the character 4 is loaded first and the column data for character 1 is loaded last in the following manner: The 7 data bits for column 1, character 4 are loaded into the on-board shift register. Next, the 7 data bits for column 1, character 3 are loaded into the on-board shift register, shifting the character 4 data over one character position. This process is repeated until all 28 bits of column data are loaded into the on-board shift register. Then, the column 1 input is energized to illuminate column 1s in all four characters. The procedure is repeated for columns 2, 3, 4, and 5.

The light output of the display may be dimmed by pulse width modulating (PWM) the blanking input V_B , with the brightness being in direct proportion to the LED on-time. When the blanking input is at logic high the display is illuminated and when the blanking input is at logic low the display is blanked. These displays may be dimmed by PWM on the order of a 2000:1 change in brightness while maintaining light output and color uniformity between characters.

The LED on-time duty factor, DF, may be determined when the time to load the on-board shift register, t , the column on-time without blanking, T , and the time display is blanked, TB , are known:

$$DF = \frac{T}{5(t + T + TB)}$$

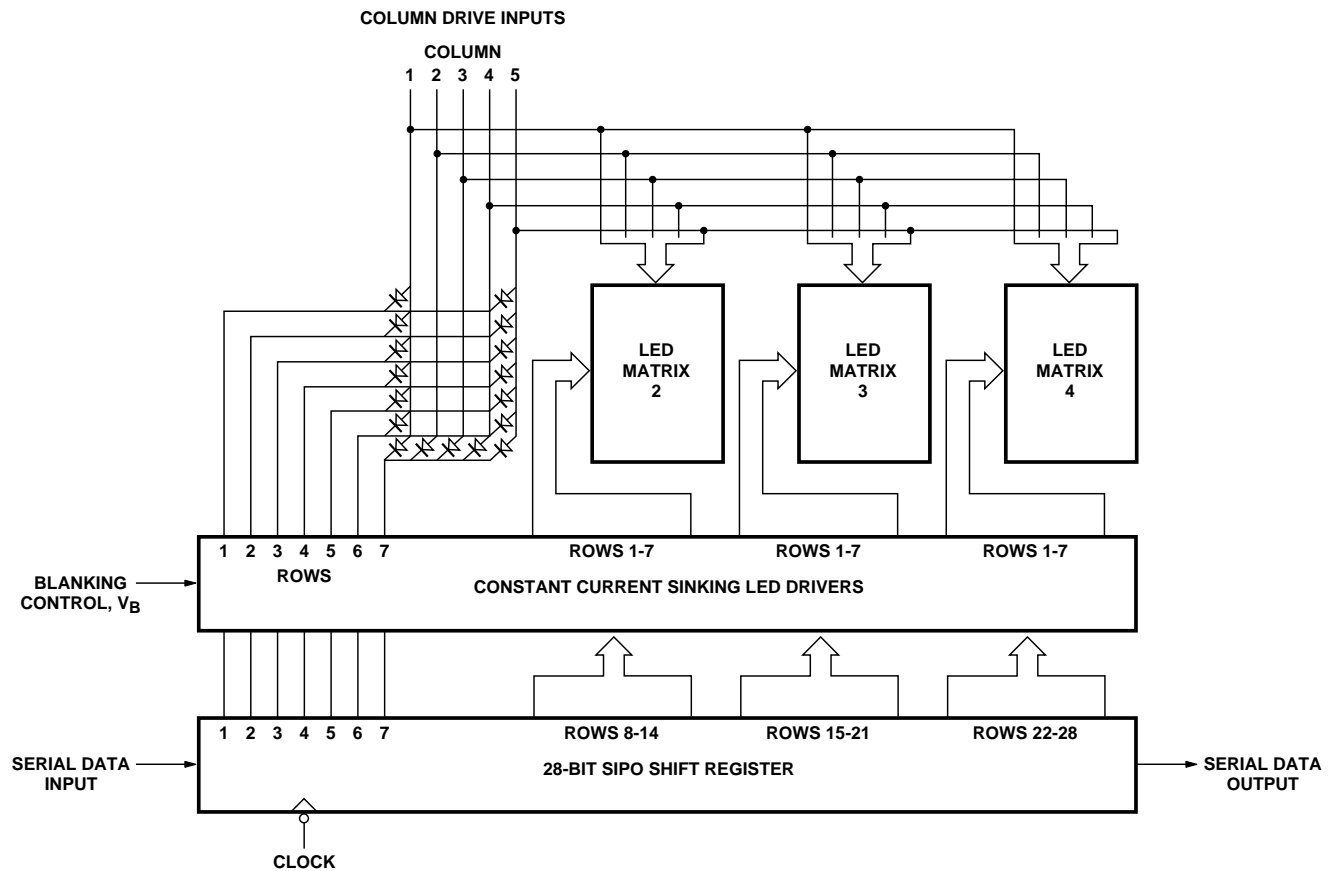

Figure 5. Block Diagram of an HDSP-235X Series LED Alphanumeric Display.

Where: $5(t + T + TB)$ is
1/column refresh rate

The column driver inputs should be strobed at a refresh rate of 100 Hz or faster to achieve a flicker free display. The value of DF approaches 20% when $TB = 0$ and t is very small compared to T .

The ESD susceptibility of these IC devices is Class A of MIL-STD-883 or Class 2 of DOD-STD-1686 and DOD-HDBK-263.

For information on interfacing these displays to microprocessor data sources and techniques for intensity control, see *Application Note 1016*.

Power Dissipation and Low Thermal Resistance Design Considerations

The light output of the HDSP-235X devices is a function of temperature, decreasing 1.5% for each 1°C increase in junction temperature. Therefore, it is desirable to maintain as low device junction temperature as possible to insure sufficient light output for sunlight readability. This is preferably achieved by designing for a low junction to ambient thermal resistance, or alternatively by controlling total display power dissipation by derating, see data sheet Figure 2.

Power Dissipation Calculation:

Power dissipation may be calculated using the equations of Figure 6a. For typical applications, the average pixel count per character is 15. The maximum power dissipation is calculated with a pixel count of 20 per character. As demonstrated in Figure 6c, the maximum power

dissipation is 1.741 W with $DF = 20\%$, $V_{CC} = 5.25$ V and $V_{COL} = 3.5$ V. The average power dissipation is 1.161 W per device with $DF = 20\%$, $V_{CC} = 5.0$ V and $V_{COL} = 3.5$ V.

As shown in Figure 4 on the data sheet, the column current, I_{COL} , is constant when the column input voltage, V_{COL} , is at 2.75 V or greater. Setting V_{COL} substantially greater than 2.75 V does not increase light output, but does add to device total power dissipation. For optimum performance, it is recommended that V_{COL} be set between 2.75 V and 3.5 V.

Junction Temperature and Device Thermal Resistance:

It is necessary to control the IC junction temperature, $T_J(IC)$, to insure proper operation of the display:

$$T_J(IC)_{MAX} = 125^{\circ}C$$

The equations to calculate $T_J(IC)$ are given in Figure 6b. $T_J(IC)$ will be higher than the device substrate temperature where as the individual LED pixel junction temperatures, $T_J(LED)$, will be nearly the same as the substrate temperature. A sample calculation is presented in Figure 6c.

An easy design rule is to obtain an IC junction to ambient thermal resistance, $R_{\theta_{J-A}}$, that establishes the device pin temperature less than 100°C. The value of $R_{\theta_{J-A}} = 23^{\circ}C/W$ will permit device operation in an ambient temperature of 85°C, without derating. Figure 7 gives the maximum values for $R_{\theta_{J-A}}$ for reliable device operation in ambient temperatures from 25°C to 85°C.

To achieve a low value of $R_{\theta_{PIN-A}}$, the following designs may be incorporated into the display system:

1. Mount the displays on a double sided maximum metalized PC board, as illustrated in Figure 8.

For single line display assemblies, a double sided maximum metalized PC board is a cost effective way to achieve a low thermal resistance to ambient. "Lands" are used instead of "traces" as the current carrying elements. Each "land" is made as wide as possible, consistent with circuit layout restrictions, to achieve metalized surface area to radiate thermal energy. Isolation strips, 0.64 mm (0.025 inch) wide, are etched from the board to electrically isolate the lands. PC board thermal resistance values in the range of 35°C/W per device are achievable for single line display assemblies. Air flow across the display PC board assembly dissipates the heat.

2. Install a metal plate, or bar, between the display packages and the PC board, with the bar mechanically fastened to the chassis, as illustrated in Figure 9a.

For multiple display lines, a metal plate may be placed between the display packages and the PC board to conduct the heat to the chassis housing assembly. The metal plate may be electrically insulated from the PC board by a thermally conductive insulator. Heat sink bars are formed in the metal plate by milling out lead clearance slots. The ceramic package of a display rests on one of the heat sink bars with the device leads passing through the slots to make electrical contact with the PC board. The heat is transferred from the display ceramic package into the metal plate. The chassis housing acts as the thermal radiator to dissipate the heat into the surrounding

environment. The metal plate must be mechanically fastened to the housing assembly, otherwise it will act only as a thermal capacitor and will not dissipate the heat.

3. Install a heat pipe between the display packages and the PC board, with the heat pipe mechanically fastened to the chassis housing, as shown in Figure 9b.

The heat pipe is a low mass alternative to the metal plate described above. A heat pipe is a small tube, filled with a chemical, that transfers heat from the source to a heat sink with minimal thermal impedance. It is not a heat sink. The heat pipe transfers

the heat directly from the display ceramic package to the chassis housing which dissipates the heat into the surrounding air.

4. Utilize a heat pipe to transfer the heat from a maximum metalized PC board to a finned heat sink mounted on the back of the assembly housing, as shown in Figure 10.

The heat pipe is placed against the back side of a maximum metalized PC board, electrically isolated by a thermally conductive insulator. When the heat pipe is connected to a finned heat sink on the back of the chassis housing, PC board to external ambient thermal resistance values in the range of 10 to 15°C/W

per device can be achieved. The heat generated by the displays is directly dissipated into the external ambient surrounding the chassis housing by the finned heat sink.

Contact the following manufacturers for information on:

Heat Pipe Technology:

Noren Products
3545 Haven Avenue
Menlo Park, CA 94025
(650) 365-0632

Thermally Conductive Insulators; "Sil-Pad":

Bergquist Company
5300 Edina Industrial Blvd.
Minneapolis, MN 55435
(612) 835-2322

$PD = P(I_{CC}) + P(I_{REF}) + P(I_{COL})$; Total power dissipation per device.

Where: $P(I_{CC}) = I_{CC} (V_B = 0.4 V) \cdot V_{CC}$; Power dissipated by the two ICs when the display is blanked.

$P(I_{REF}) = 5 \cdot [I_{CC} (V_B = 2.4 V) - I_{CC} (V_B = 0.4 V)] \cdot V_{CC} \cdot (n/35) \cdot DF$; Additional power dissipated by the two ICs with characters illuminated.

$P(I_{COL}) = 5 \cdot I_{COL} \cdot V_{COL} (n/35) \cdot DF$; Power dissipated by the LED pixels when the characters are illuminated.

n = 15 pixels per character for average power.

n = 20 pixels per character for maximum power.

Figure 6a. Equations for Calculating Device Power Dissipation.

$\Delta T_J (IC) = R_{\theta_{J-PIN}} \cdot PD$; IC junction temperature rise above device pin temperature.

Where: $R_{\theta_{J-PIN}} = 10^\circ C/W$; The thermal resistance IC junction to device pin 1.

$\Delta T_{PIN} = R_{\theta_{PIN-A}} \cdot PD$; Device pin temperature rise above the ambient temperature, T_A .

Where: $R_{\theta_{PIN-A}}$ = The thermal resistance, device pin to ambient through the PC board, on a per device basis.

$T_J(IC) = T_A + [\Delta T_J(IC) + \Delta T_{PIN}]$; IC junction temperature, the sum of the ambient temperature and the temperature rise above ambient.

Figure 6b. Equations for Calculating IC Junction.

Device Maximum Power Dissipation:

IC Maximum Power Dissipation:

$$P(I_{CC}) = (0.060A) (5.25 V) = 0.315 W$$

$$P(I_{REF}) = 5(0.100 A - 0.060 A) (5.25 V) (20/35) (1/5) = 0.120 W$$

I_{COL} Power Dissipation:

$$P(I_{COL}) = 5(0.653 A) (3.5 V) (20/35) (1/5) = 1.306 W$$

Device Maximum Power Dissipation:

$$PD(MAX) = 0.315 W + 0.120 W + 1.306 W = 1.741 W$$

IC Junction Temperature, T_A = 85°C:

IC Junction Temperature Rise Above Substrate Pin:

$$\Delta T_J(IC) = (10^\circ C/W) (1.741 W) = 17.4^\circ C \text{ Rise}$$

Device Pin Temperature Rise Above Ambient:

Delta T (PIN) = (13°C/W) (1.741 W) = 22.6°C Rise IC Junction Temperature:

$$T_J(IC) = 85^\circ C + (17.4^\circ C + 22.6^\circ C) = 125.0^\circ C$$

Note:

I_{CC} and I_{COL} values taken from the data sheet Electrical Characteristics. R_{θJ-PIN} = 10°C/W and R_{θJ-PIN-A} = 13°C/W.

Figure 6c. Sample Calculation of Device Maximum Power Dissipation and IC Junction Temperature for an HDSP-235X Series Device Operating in an Ambient of T_A = 85°C.

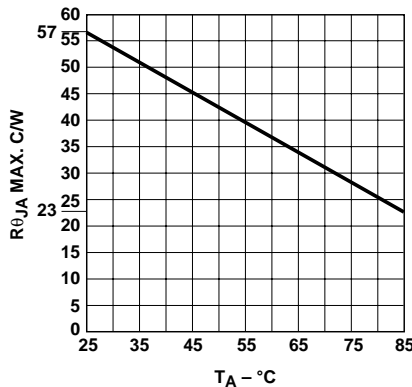

Figure 7. Maximum Thermal Resistance IC Junction to Ambient, R_{θJ-A}, vs. Ambient Temperature. Based on: P_D MAX. = 1.741 W, T_J (IC) MAX. = 125°C.

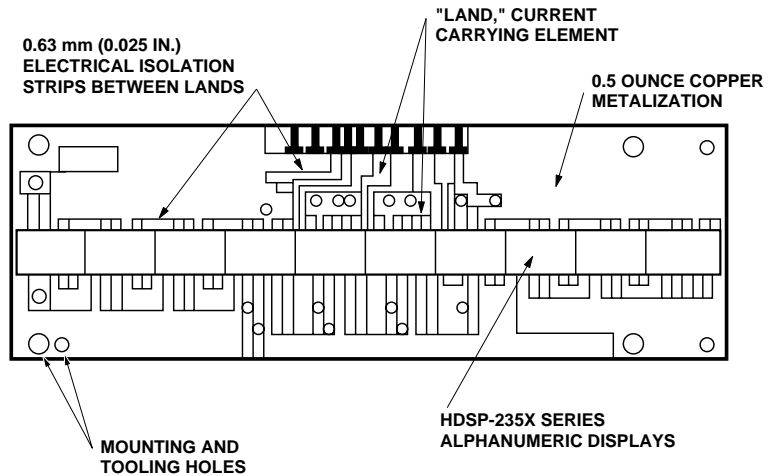

Figure 8. Maximum Metalized PC Board, Double Sided, for Mounting HDSP-235X Series Displays.

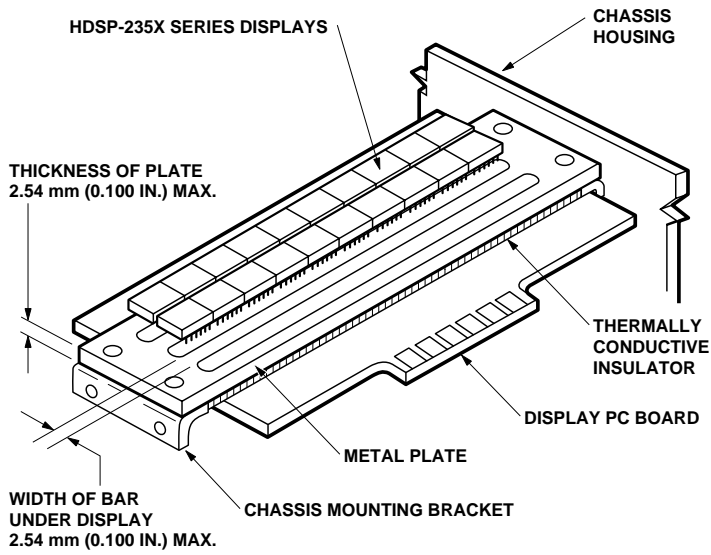

Figure 9a. Metal Plate Mounted Between Display Devices and PC Board, Mechanically Fastened to Chassis Housing.

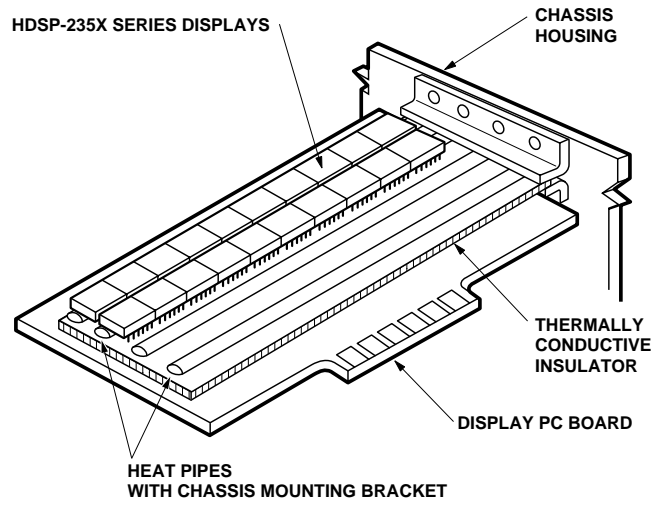

Figure 9b. Heat Pipes Mounted Between Display Devices and PC Board, Mechanically Fastened to Chassis Housing.

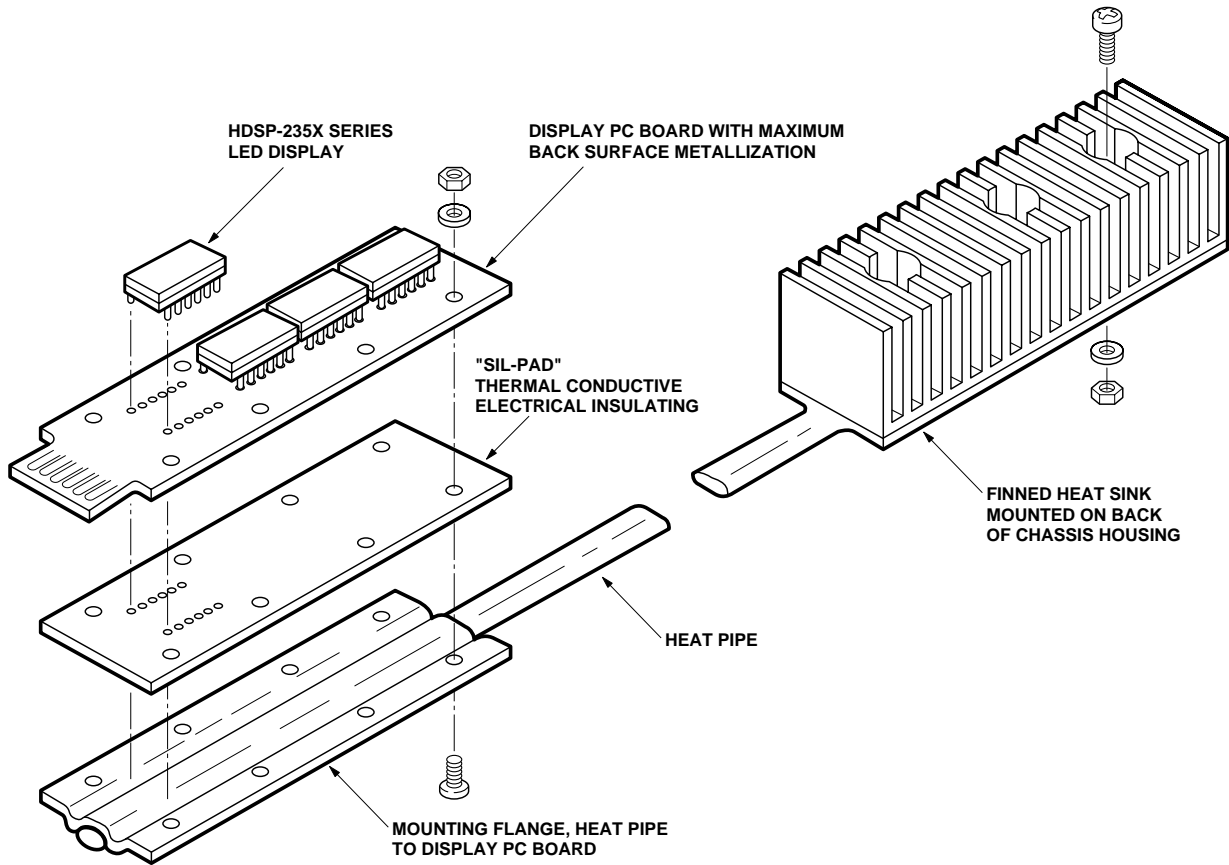

Figure 10. Using a Heat Pipe to Transfer Display Generated Heat to an Externally Mounted Finned Heat Sink.

Contrast Enhancement

For more information on Contrast Enhancement, please consult *Application Notes 1015 and 1029*.

For product information and a complete list of distributors, please go to our website: www.avagotech.com

Avago, Avago Technologies, and the A logo are trademarks of Avago Technologies Limited in the United States and other countries. Data subject to change. Copyright © 2007 Avago Technologies Limited. All rights reserved. Obsoletes 5954-8411 5966-1858E October 22, 2007

Avago
TECHNOLOGIES