

Technical Data

S1552 Series



Description

A voltage controlled PECL crystal oscillator designed primarily for use in phase locked loops, Sonet, ATM, SDH and network/switch applications. Output is Motorola 10KH compatible. Device is packaged in a 14-pin DIP compatible, resistance welded package. Case is grounded to Pin 7 to reduce EMI.

Applications & Features

- Positive supply voltage 5V ECL (PECL)
- ~ Output enable/disable feature
- Single output
- Wide frequency range from 77.76 MHz to 155.52 MHz using SaRonix fundamental crystals for exceptional jitter performance
- Covers a wide range of telecommunication applications such as Sonet, ATM and SDH
- ± 50 or ± 100 ppm minimum APR*

Output Waveforms

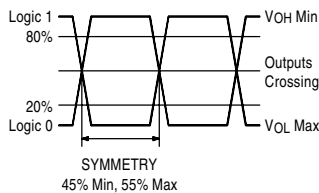

Frequency Range:	77.76 MHz to 155.52 MHz
Frequency Stability:	± 50 , or ± 100 ppm over all conditions: operating temperature, supply voltage change, load change, calibration tolerance, aging**, shock and vibration.
Aging**:	5 years @ 40°C ambient operating temperature range
Temperature Range:	Operating: 0 to +70°C, 0 to +85°C, -40 to +85°C Storage: -55°C to +105°C
Supply Voltage (VCC):	5V $\pm 5\%$
Supply Current:	70mA typ, 100mA max
Output Drive:	Symmetry: 45/55% max @ 50% waveform Rise & Fall Times: 1ns max Logic 0: VCC -1.62 max Logic 1: VCC -1.02 min Load: 50 Ω to VCC -2V (output requires termination) Jitter: 3.5ps max RMS period jitter
Pull Characteristics:	Input Impedence (Pin 1): 50K Ω min Frequency Response (-3dB): 10kHz min Pullability: ± 50 or ± 100 ppm min APR* Control Voltage: 0.5V to 4.5V Transfer Function: Frequency increases when control voltage increases Linearity: 10% monotonic Center Control Voltage: 2.5V
Mechanical:	Shock: MIL-STD-202, Method 213, Condition F Solderability: MIL-STD-883, Method 2003 Terminal Strength: MIL-STD-202, Method 211, Conditions A & C Vibration: MIL-STD-883, Method 2007, Condition A Solvent Resistance: MIL-STD-202, Method 215 Resistance to Soldering Heat: MIL-STD-202, Method 210, Condition A, B or C (I or J for Gull-wing)
Environmental:	Gross Leak Test: MIL-STD-883, Method 1014, Condition C Fine Leak Test: MIL-STD-883, Method 1014, Condition A2 Thermal Shock: MIL-STD-883, Method 1011, Condition A Moisture Resistance: MIL-STD-883, Method 1004

*APR = (VCXO Pull relative to specified Output Frequency) – (VCXO Freq. Stability) – (Aging)

Technical Data

S1552 Series

Package Details

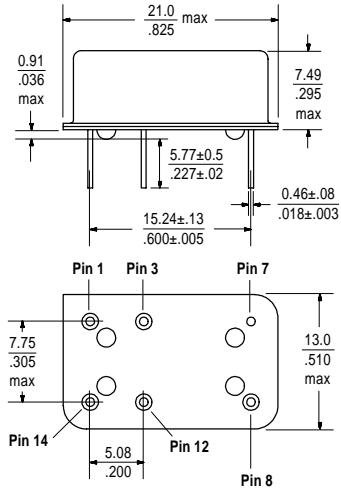

Gull Wing Package

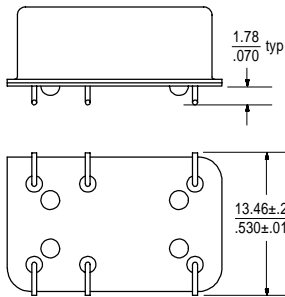

Pin Functions:

- S1552
 Pin 1: Control Voltage Pin 8: Q Output
 Pin 3: Enable Pin 12: N/C
 Pin 7: GND / Case Pin 14: Supply Voltage

Marking Format **

Includes Date Code, Frequency & Model

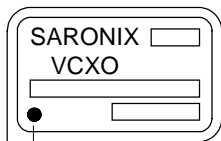

Denotes Pin 1

**Exact location of items may vary

Scale: None (Dimensions in $\frac{mm}{inches}$)

Part Numbering Guide

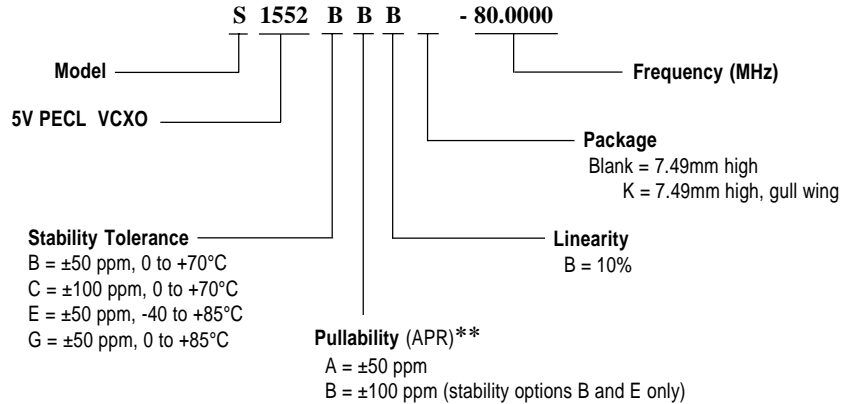

**APR = (VCXO Pull relative to specified Output Frequency) – (VCXO Freq. Stability) – (Aging)

Test Circuit

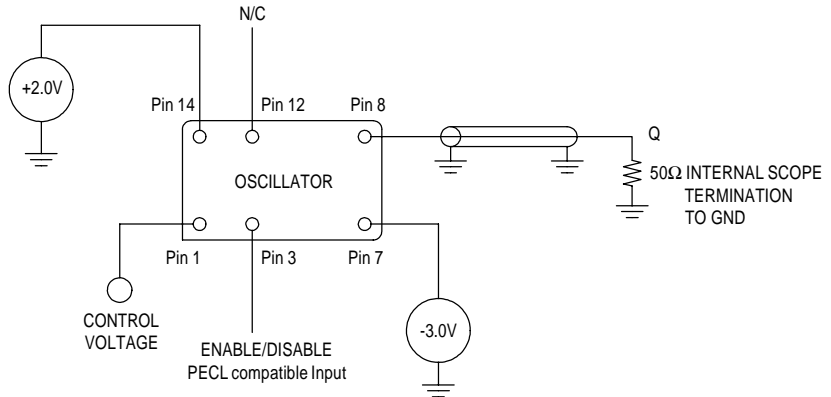

All specifications are subject to change without notice.