



## U74HC238

Preliminary

CMOS IC

### 3 TO 8 LINE DECODER/DEMULTIPLEXER

#### DESCRIPTION

The **U74HC238** decodes three binary weighted address inputs (A0, A1 and A2) to eight mutually exclusive outputs (Y0 to Y7). The device features three enable inputs ( $\bar{E}1$  and  $\bar{E}2$  and E3). Every output will be LOW unless  $\bar{E}1$  and  $\bar{E}2$  are LOW and E3 is HIGH. This multiple enable function allows easy parallel expansion to a 1-of-32 (5 to 32 lines) decoder with just four **U74HC238** ICs and one inverter. The **U74HC238** can be used as an eight output demultiplexer by using one of the active LOW enable inputs as the data input and the remaining enable inputs as strobes. Inputs include clamp diodes. This enables the use of current limiting resistors to interface inputs to voltages in excess of  $V_{CC}$ .

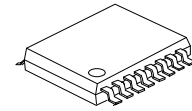

TSSOP-16

#### FEATURES

- \* Demultiplexing capability
- \* Multiple input enable for easy expansion
- \* Ideal for memory chip select decoding
- \* Active HIGH mutually exclusive outputs

#### ORDERING INFORMATION

Ordering Number		Package	Packing
Lead Free	Halogen Free		
U74HC238L-P16-R	U74HC238G-P16-R	TSSOP-16	Tape Reel

<p>U74HC238G-P16-R</p> <p>(1) Packing Type</p> <p>(2) Package Type</p> <p>(3) Green Package</p>	<p>(1) R: Tape Reel</p> <p>(2) P16: TSSOP-16</p> <p>(3) G: Halogen Free and Lead Free, L: Lead Free</p>
---	---

#### MARKING

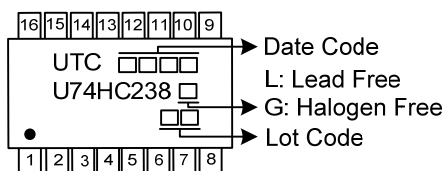

■ PIN CONFIGURATION

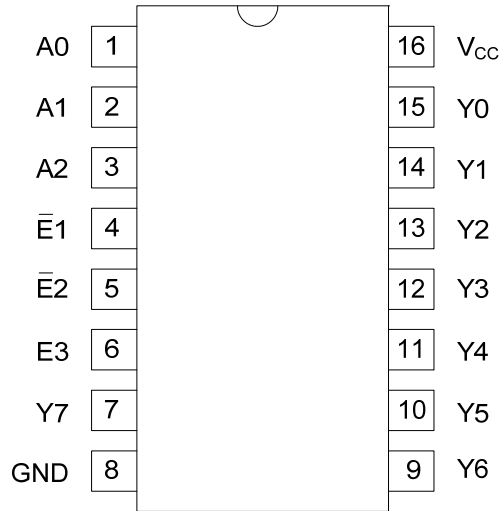

■ FUNCTION TABLE

$\bar{E}1$	$\bar{E}2$	E3	A0	A1	A2	Y0	Y1	Y2	Y3	Y4	Y5	Y6	Y7
H	X	X	X	X	X	L	L	L	L	L	L	L	L
X	H	X	X	X	X	L	L	L	L	L	L	L	L
X	X	L	X	X	X	L	L	L	L	L	L	L	L
L	L	H	L	L	L	H	L	L	L	L	L	L	L
L	L	H	H	L	L	L	H	L	L	L	L	L	L
L	L	H	L	H	L	L	L	H	L	L	L	L	L
L	L	H	H	H	L	L	L	L	H	L	L	L	L
L	L	H	L	L	H	L	L	L	L	H	L	L	L
L	L	H	H	L	H	L	L	L	L	L	H	L	L
L	L	H	L	H	H	L	L	L	L	L	L	H	L
L	L	H	H	H	H	L	L	L	L	L	L	L	H

H = High Voltage level ; L = Low Voltage level ; X = Don't care

■ LOGIC SYMBOL

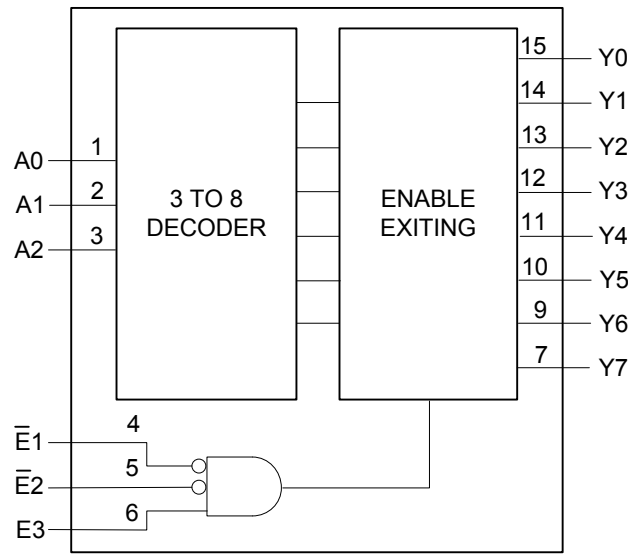

■ FUNCTION DIAGRAM

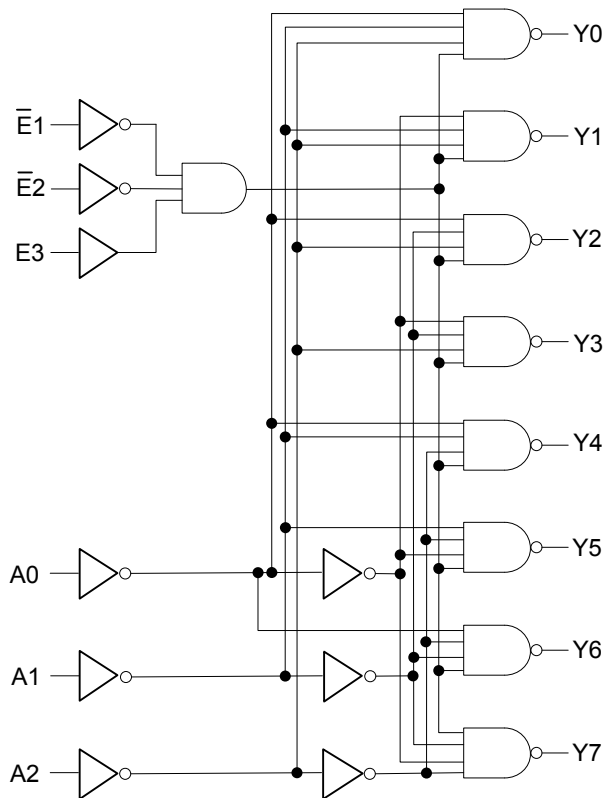

### ■ ABSOLUTE MAXIMUM RATING

PARAMETER	SYMBOL	CONDITIONS	RATINGS	UNIT
Supply Voltage	$V_{CC}$		-0.5 ~ 7	V
Continuous Output Current	$I_{OUT}$	$-0.5V < V_{OUT} < V_{CC} + 0.5V$	±25	mA
Input Clamp Current	$I_{IK}$	$V_{IN} < -0.5V$ or $V_{IN} > V_{CC} + 0.5V$	±20	mA
Output Clamp Current	$I_{OK}$	$V_{OUT} < -0.5V$ or $V_{OUT} > V_{CC} + 0.5V$	±20	mA
Supply Current	$I_{CC}$		50	mA
Ground Current	$I_{GND}$		-50	mA
Storage Temperature Range	$T_{STG}$		-65 ~ +150	°C

Note: Absolute maximum ratings are those values beyond which the device could be permanently damaged. Absolute maximum ratings are stress ratings only and functional device operation is not implied.

### ■ RECOMMENDED OPERATING CONDITIONS

PARAMETER	SYMBOL	CONDITIONS	MIN	TYP	MAX	UNIT
Supply Voltage	$V_{CC}$		2.0	5.0	6.0	V
High-Level Input Voltage	$V_{IH}$	$V_{CC}=2V$	1.5	1.2		V
		$V_{CC}=4.5V$	3.15	2.4		
		$V_{CC}=6V$	4.2	3.2		
Low-Level Input Voltage	$V_{IL}$	$V_{CC}=2V$		0.8	0.5	V
		$V_{CC}=4.5V$		2.1	1.35	
		$V_{CC}=6V$		2.8	1.8	
Input Voltage	$V_{IN}$		0		$V_{CC}$	V
Output Voltage	$V_{OUT}$		0		$V_{CC}$	V
Input Transition Rise or Fall Rate	$\Delta t/\Delta V$	$V_{CC}=2V$			625	ns/V
		$V_{CC}=4.5V$		1.67	139	
		$V_{CC}=6V$			83	
Operating Temperature	$T_A$		-40		+125	°C

### ■ ELECTRICAL CHARACTERISTICS ( $T_A = 25^\circ\text{C}$ , unless otherwise specified)

PARAMETER	SYMBOL	TEST CONDITIONS	MIN	TYP <sup>(1)</sup>	MAX	UNIT
High-Level Output Voltage	$V_{OH}$	$V_{CC}=2V, I_{OH}=-20\mu A$	1.9	2.0		V
		$V_{CC}=4.5V, I_{OH}=-20\mu A$	4.4	4.5		
		$V_{CC}=6V, I_{OH}=-20\mu A$	5.9	6.0		
		$V_{CC}=4.5V, I_{OH}=-4mA$	3.98	4.32		
		$V_{CC}=6V, I_{OH}=-5.2mA$	5.48	5.81		
Low-Level Output Voltage	$V_{OL}$	$V_{CC}=2V, I_{OL}=20\mu A$		0	0.1	V
		$V_{CC}=4.5V, I_{OL}=20\mu A$		0	0.1	
		$V_{CC}=6V, I_{OL}=20\mu A$		0	0.1	
		$V_{CC}=4.5V, I_{OL}=4mA$		0.15	0.26	
		$V_{CC}=6V, I_{OL}=5.2mA$		0.16	0.26	
Input Leakage Current	$I_{I(LEAK)}$	$V_{CC}=6V, V_I=V_{CC}$ or GND			±0.1	μA
Quiescent Supply Current	$I_{CC}$	$V_{CC}=6V, V_I=V_{CC}$ or GND, $I_{OUT}=0A$			8	μA
Input Capacitance	$C_I$			3.5		pF

■ SWITCHING CHARACTERISTICS ( $T_A=25^\circ\text{C}$ , unless otherwise specified)

PARAMETER	SYMBOL	TEST CONDITIONS	MIN	TYP	MAX	UNIT	
Propagation delay from input (An) to output (Yn)	$t_{PD}$	$V_{CC}=2.0\text{V}$		25	150	ns	
		$V_{CC}=4.5\text{V}$		17	30	ns	
		$V_{CC}=5.0\text{V}, C_L=15\text{pF}$		14		ns	
		$V_{CC}=6.0\text{V}$		10	26	ns	
Propagation delay from input (E3) to output (Yn)		$V_{CC}=2.0\text{V}$			22	160	ns
		$V_{CC}=4.5\text{V}$			19	32	ns
		$V_{CC}=5.0\text{V}, C_L=15\text{pF}$			16		ns
		$V_{CC}=6.0\text{V}$			8	27	ns
Propagation delay from input ( $\bar{E}n$ ) to output (Yn)		$V_{CC}=2.0\text{V}$			20	155	ns
		$V_{CC}=4.5\text{V}$			18	31	ns
		$V_{CC}=5.0\text{V}, C_L=15\text{pF}$			17		ns
		$V_{CC}=6.0\text{V}$			6	26	ns
Transition Time	$t_t$	$V_{CC}=2.0\text{V}$		19	75	ns	
		$V_{CC}=4.5\text{V}$		7	15	ns	
		$V_{CC}=6.0\text{V}$		6	13	ns	

■ OPERATING CHARACTERISTICS ( $T_A=25^\circ\text{C}$ , unless otherwise specified)

PARAMETER	SYMBOL	TEST CONDITIONS	MIN	TYP	MAX	UNIT
Power Dissipation Capacitance	$C_{PD}$	$V_{IN}=\text{GND or } V_{CC}$		76		pF

■ TEST CIRCUIT AND WAVEFORMS

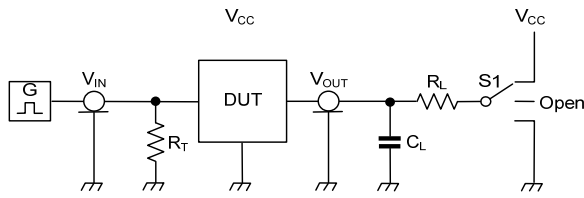

Load Circuit

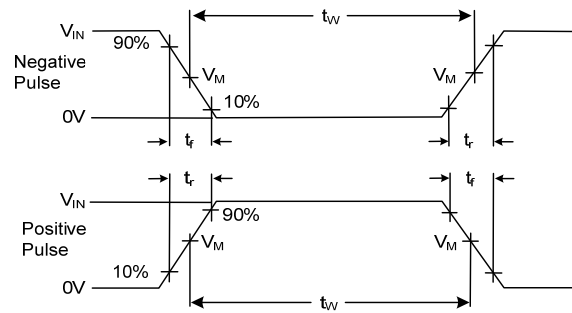

Test Circuit For Measuring Switching Times

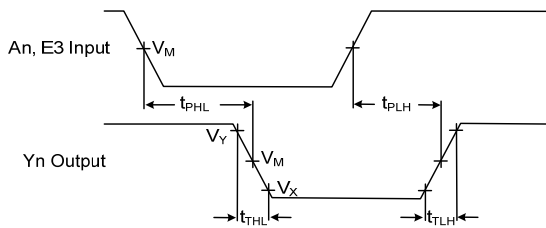

Input ( $\bar{A}_n, \bar{E}_3$ ) to Output ( $Y_n$ ) Propagation Delays And Output Transition Times

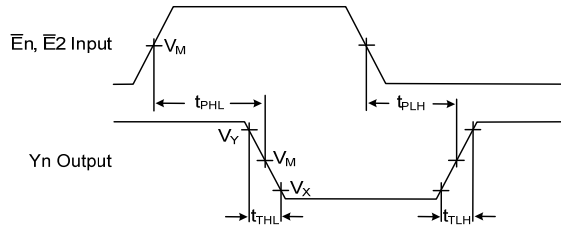

Input ( $E_1, E_2$ ) to Output ( $Y_n$ ) Propagation Delays And Output Transition Times

Table 1. Measurement Points

Input	Output		
$V_M$	$V_M$	$V_X$	$V_Y$
$0.5 \times V_{CC}$	$0.5 \times V_{CC}$	$0.1 \times V_{CC}$	$0.9 \times V_{CC}$

Table 2. Test data

Input		Load		S1 Position
$V_{IN}$	$t_r, t_f$	$C_L$	$R_L$	$t_{PHL}, t_{PLH}$
$V_{CC}$	6nS	15pF, 50pF	1k $\Omega$	Open

Note:  $V_{OL}$  and  $V_{OH}$  are typical voltage output levels that occur with the output load.

UTC assumes no responsibility for equipment failures that result from using products at values that exceed, even momentarily, rated values (such as maximum ratings, operating condition ranges, or other parameters) listed in products specifications of any and all UTC products described or contained herein. UTC products are not designed for use in life support appliances, devices or systems where malfunction of these products can be reasonably expected to result in personal injury. Reproduction in whole or in part is prohibited without the prior written consent of the copyright owner. UTC reserves the right to make changes to information published in this document, including without limitation specifications and product descriptions, at any time and without notice. This document supersedes and replaces all information supplied prior to the publication hereof.