

66173

GULL WING HERMETICALLY SEALED DUAL CHANNEL OPTOCOUPLER (Electrically Similar to 6N134)



2-24-16

Features:

- 5 MHz bandwidth typical
1000 Vdc isolation test voltage
TTL compatible input and output
High radiation immunity
Faraday shield to provide high common mode rejection

Applications:

- Military and Space
High reliability systems
Voltage Level Shifting
Isolated Receiver Input
Communication systems
Medical systems

DESCRIPTION

The 66173 Dual Channel Optocoupler consists of two LEDs optically coupled to two high speed, high gain inverting detector gates. Maximum isolation can be achieved while providing TTL outputs capable of switching with propagation delays of 65ns typical. The 66173 is a 10 pin gull wing hermetically sealed package and is available in standard and screened versions or tested to customer specifications.

ABSOLUTE MAXIMUM RATINGS

Table with 2 columns: Parameter and Rating. Includes Peak Forward Input Current (40 mA), Average Forward Input Current (20 mA), Input Power Dissipation (35 mW), Reverse Input Voltage (5 V), Supply Voltage (7 V), Output Current (25 mA), Output Power Dissipation (40 mW), Output Voltage (7 V), Total Power Dissipation (350 mW), Storage Temperature (-65°C to +150°C), Operating Free-Air Temperature Range (-55°C to +125°C), Lead Solder Temperature (260°C).

Package Dimensions

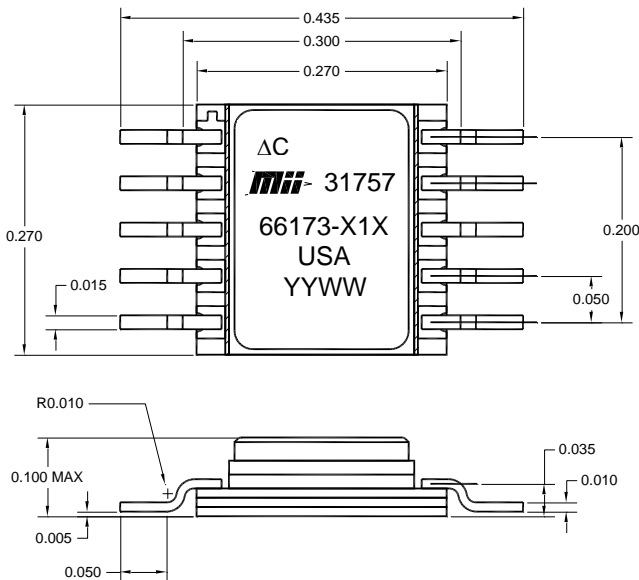

ALL DIMENSIONS IN INCHES

Schematic Diagram

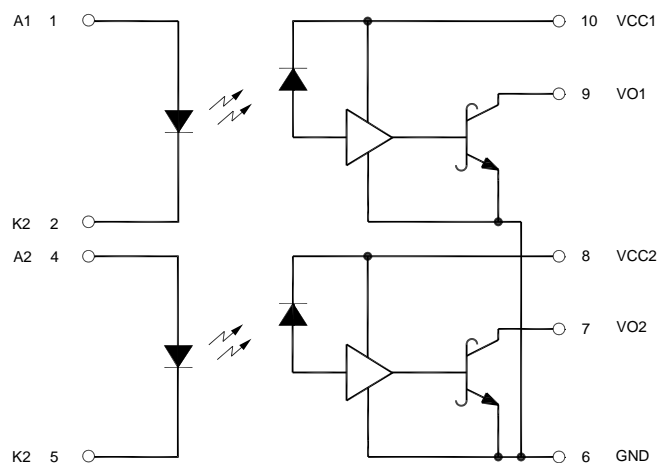

NOTE: 0.01 TO 0.1µf BYPASS CAPACITOR MUST BE CONNECTED BETWEEN PINS 6 AND 8, 6 AND 10.

Micropac Industries cannot assume any responsibility for any circuits shown or represent that they are free from patent infringement. Micropac Industries reserves the right to make changes at any time in order to improve design and to supply the best product possible.

**66173 GULL WING HERMETICALLY SEALED DUAL CHANNEL OPTOCOUPLER (Electrically Similar to 6N134)**

**ELECTRICAL CHARACTERISTICS**  $T_a = -55^{\circ}\text{C}$  to  $125^{\circ}\text{C}$  unless otherwise specified.

Parameter	Symbol	Min	Typ.	Max	Units	Test Conditions	Note
High Level Output Current	$I_{OH}$		20	250	$\mu\text{A}$	$V_{CC} = 5.5\text{ V}$ , $V_O = 5.5\text{ V}$ , $I_F = 100\ \mu\text{A}$	1, 9
Low Level Output Voltage	$V_{OL}$		0.35	0.6	V	$V_{CC} = 5.5\text{ V}$ , $I_F = 10\text{ mA}$ $I_{OL}$ (Sinking) = 10 mA	1
High Level Supply Current	$I_{CCH}$		18	28	mA	$V_{CC} = 5.5\text{ V}$ , $I_F = 0$ (Both Channels)	
Low Level Supply Current	$I_{CCL}$		26	36	mA	$V_{CC} = 5.5\text{ V}$ , $I_F = 20\text{ mA}$ (Both Channels)	
Input Forward Voltage	$V_F$		1.5	1.8	V	$I_F = 20\text{ mA}$	1
Input Reverse Breakdown Voltage	$BV_R$	5			V	$I_R = 10\ \mu\text{A}$	
Input-Output Insulation Leakage Current	$I_{I-O}$			1.0	$\mu\text{A}$	$V_{I-O} = 1000\text{ Vdc}$ , Relative Humidity = 45% $T_a = 25^{\circ}\text{C}$ , $t = 5\text{ s}$	2
Propagation Delay Time To High Output Level	$t_{PLH}$		65	100	ns	$R_L = 510\ \Omega$ , $C_L = 15\text{ pF}$ $I_F = 13\text{ mA}$ , $T_a = 25^{\circ}\text{C}$	5
Propagation Delay Time To Low Output Level	$t_{PHL}$		55	100	ns	$R_L = 510\ \Omega$ , $C_L = 15\text{ pF}$ $I_F = 13\text{ mA}$ , $T_a = 25^{\circ}\text{C}$	6

**TYPICAL CHARACTERISTICS**  $T_a = 25^{\circ}\text{C}$ ,  $V_{CC} = 5\text{ V}$  each channel

Parameter	Symbol	Min	Max	Units	Test Conditions	Note
Input Capacitance	$C_{IN}$		60	pF	$V_F = 0$ , $f = 1\text{ MHz}$	1
Input Diode Temperature Coefficient	$\frac{\Delta V_F}{\Delta T_a}$		-1.9	mV/ $^{\circ}\text{C}$	$I_F = 20\text{ mA}$	1
Resistance (Input-Output)	$R_{I-O}$		$10^{12}$	$\Omega$	$V_{I-O} = 500\text{ V}$	3
Capacitance (Input-Output)	$C_{I-O}$		1.7	pF	$f = 1\text{ MHz}$	3
Input-Input Insulation Leakage Current	$I_{I-I}$		0.5	nA	Relative Humidity = 45% $V_{I-I} = 500\text{ V}$ , $t = 5\text{ s}$	4
Resistance (Input-Input)	$R_{I-I}$		$10^{12}$	$\Omega$	$V_{I-I} = 500\text{ V}$	4
Capacitance (Input-Input)	$C_{I-I}$		0.80	pF	$f = 1\text{ MHz}$	4
Output Rise-Fall Time (10-90%)	$t_r$ , $t_f$		35	ns	$R_L = 510\ \Omega$ , $C_L = 15\text{ pF}$ $I_F = 13\text{ mA}$	
Common Mode Transient Immunity at High Output Level	$CM_H$	1000	10000	V/ $\mu\text{s}$	$V_{CM} = 10\text{ V}$ (peak), $V_O$ (min) = 2 V, $R_L = 510\ \Omega$ , $I_F = 0\text{ mA}$	7
Common Mode Transient Immunity at Low Output Level	$CM_L$	1000	10000	V/ $\mu\text{s}$	$V_{CM} = 10\text{ V}$ (peak), $V_O$ (max) = 0.8 V, $R_L = 510\ \Omega$ , $I_F = 10\text{ mA}$	8

**Notes:**

- Each channel
- Measured between pins 1 through 5 shorted together and pins 6 through 10 shorted together.
- Measured between pins 1 and 2 or 4 and 5 shorted together, and pins 6 through 10 shorted together.
- Measured between pins 1 and 2 shorted together, and pins 4 and 5 shorted together.
- The  $t_{plh}$  propagation delay is measured from the 6.5 mA point on the trailing edge of the input pulse to the 1.5 V point on the trailing edge of the output pulse.
- The  $t_{phl}$  propagation delay is measured from the 6.5 mA point on the leading edge of the input pulse to the 1.5 V point on the leading edge of the output pulse.
- $CM_H$  is the max. tolerable common mode transient to assure that the output will remain in a high logic state (i.e.  $V_o > 2.0\text{ V}$ ).
- $CM_L$  is the max. tolerable common mode transient to assure that the output will remain in a low logic state (i.e.  $V_o < 0.8\text{ V}$ ).
- It is essential that a bypass capacitor (0.01 to 0.1  $\mu\text{F}$  ceramic) be connected from pin 6 to pin 10.

**RECOMMENDED OPERATING CONDITIONS**

PARAMETER	SYMBOL	MIN	MAX	UNITS
Input Current, Low Level Each Channel	$I_{FL}$	0	100	$\mu\text{A}$
Input Current, High Level Each Channel	$I_{FH}$	12.5	20	mA
Supply Voltage	$V_C$	4.5	5.5	V
Fan Out (TTL Load) Each Channel	N		6	
Operating Temperature	$T_a$	-55	125	$^{\circ}\text{C}$

**SELECTION GUIDE**

PART NUMBER	PART DESCRIPTION
66173-010	-55 $^{\circ}\text{C}$ $T_O$ +125 $^{\circ}\text{C}$ with 100% Device Screening
66173-013	Commercial

Micropac Industries cannot assume any responsibility for any circuits shown or represent that they are free from patent infringement. Micropac Industries reserves the right to make changes at any time in order to improve design and to supply the best product possible.