

### Features

- Radial Leaded Devices
- Smaller size for similar I<sub>hold</sub> rating
- Faster tripping
- Tighter trip-to-hold ratios
- Bulk packaging, tape and reel and Ammo-Pak available on most models
- Patents pending

■ Agency recognition: (pending)

### Applications

- Automotive
- Computers and peripherals
- General electronics
- Wire harnesses

## MF-RG Series - PTC Resettable Fuses

### Electrical Characteristics

Model	V max. Volts	I max. Amps	I <sub>hold</sub>	I <sub>trip</sub>	Initial Resistance		1 Hour (R <sub>1</sub> ) Post-Trip Resistance	Max. Time To Trip		Tripped Power Dissipation
			Amperes at 23°C		Ohms at 23°C			Amperes at 23°C	Seconds at 23°C	
			Hold	Trip	Min.	Max.	Max.			
MF-RG300	16	100	3.00	5.10	0.032	—	0.105	15.0	2.0	2.3
MF-RG500	16	100	5.00	8.50	0.015	—	0.044	25.0	3.6	2.6
MF-RG700	16	100	7.00	11.90	0.008	—	0.021	35.0	8.0	3.0
MF-RG900	16	100	9.00	15.30	0.004	—	0.015	45.0	12.0	3.3
MF-RG1100	16	100	11.00	18.70	0.003	—	0.010	55.0	15.2	3.7

### Environmental Characteristics

Operating/Storage Temperature .....-40°C to +85°C  
 Maximum Device Surface Temperature in Tripped State .....125°C  
 Passive Aging.....+85°C, 1000 hours .....±5% typical resistance change  
 Humidity Aging.....+85°C, 85% R.H. 1000 hours.....±5% typical resistance change  
 Thermal Shock .....+125°C to -55°C, 10 times .....±10% typical resistance change  
 Solvent Resistance .....MIL-STD-202, Method 215 .....No change  
 Vibration.....MIL-STD-883C, Method 2007.1, .....No change  
 Condition A

### Test Procedures And Requirements For Model MF-RG Series

Test	Test Conditions	Accept/Reject Criteria
Visual/Mech.	Verify dimensions and materials	Per MF physical description
Resistance	In still air @ 23°C	R <sub>min</sub> ≤ R ≤ R <sub>max</sub>
Time to Trip	5 times I <sub>hold</sub> , V <sub>max</sub> , 23°C	T ≤ max. time to trip (seconds)
Hold Current	30 min. at I <sub>hold</sub>	No trip
Trip Cycle Life	V <sub>max</sub> , I <sub>max</sub> , 100 cycles	No arcing or burning
Trip Endurance	V <sub>max</sub> , 48 hours	No arcing or burning

UL File Number .....E 174545S\*  
 CSA File Number .....CA 110338  
 TÜV File Number .....R2057213

### Thermal Derating Chart - I<sub>hold</sub> (Amps)

Model	Ambient Operating Temperature								
	-40°C	-20°C	0°C	23°C	40°C	50°C	60°C	70°C	85°C
MF-RG300	4.4	4.0	3.6	3.0	2.6	2.4	2.1	1.9	1.4
MF-RG500	7.3	6.6	6.0	5.0	4.4	4.0	3.6	3.1	2.4
MF-RG700	10.3	9.3	8.4	7.0	6.2	5.6	5.0	4.4	3.3
MF-RG900	13.2	11.9	10.7	9.0	7.9	7.2	6.4	5.6	4.2
MF-RG1100	14.7	13.3	12.0	10.0	8.7	8.0	7.0	6.3	4.7

\*I<sub>trip</sub> is approximately two times I<sub>hold</sub>.

# MF-RG Series - PTC Resettable Fuses



## Product Dimensions

Model	A Max.	B Min.	C Min.	D Max.	E Max.	Physical Characteristics	
						Lead Dia.	Material
MF-RG300	7.1 (0.280)	10.2 (0.402)	5.2 ± 0.7 (0.205 ± 0.028)	4.6 (0.181)	3.0 (0.118)	0.81 (0.032)	Sn/Cu
MF-RG500	10.4 (0.409)	13.5 (0.531)	5.2 ± 0.7 (0.205 ± 0.028)	4.6 (0.181)	3.0 (0.118)	0.81 (0.032)	Sn/Cu
MF-RG700	11.2 (0.441)	18.8 (0.740)	5.2 ± 0.7 (0.205 ± 0.028)	4.6 (0.181)	3.0 (0.118)	0.81 (0.032)	Sn/Cu
MF-RG900	14.0 (0.551)	20.8 (0.819)	5.2 ± 0.7 (0.205 ± 0.028)	4.6 (0.181)	3.0 (0.118)	0.81 (0.032)	Sn/Cu
MF-RG1100	17.5 (0.689)	25.1 (0.988)	5.2 ± 0.7 (0.205 ± 0.028)	4.6 (0.181)	3.0 (0.118)	0.81 (0.032)	Sn/Cu

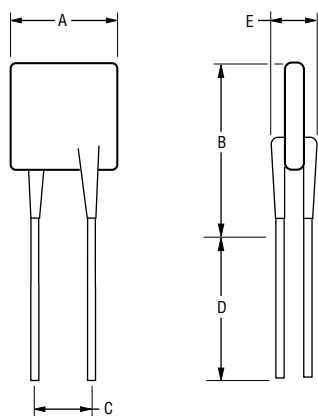

Packaging options:

BULK: 500 pcs. per bag

TAPE & REEL: MF-RG300 & MF-RG500 = 3000 pcs. per reel;

MF-RG700, MF-RG900 & MF-RG1100 = 1500 pcs. per reel

AMMO-PACK: 2000 pcs. per reel

DIMENSIONS =  $\frac{\text{MM}}{\text{INCHES}}$   
0.81 (20AWG)

## Typical Time to Trip at 23°C

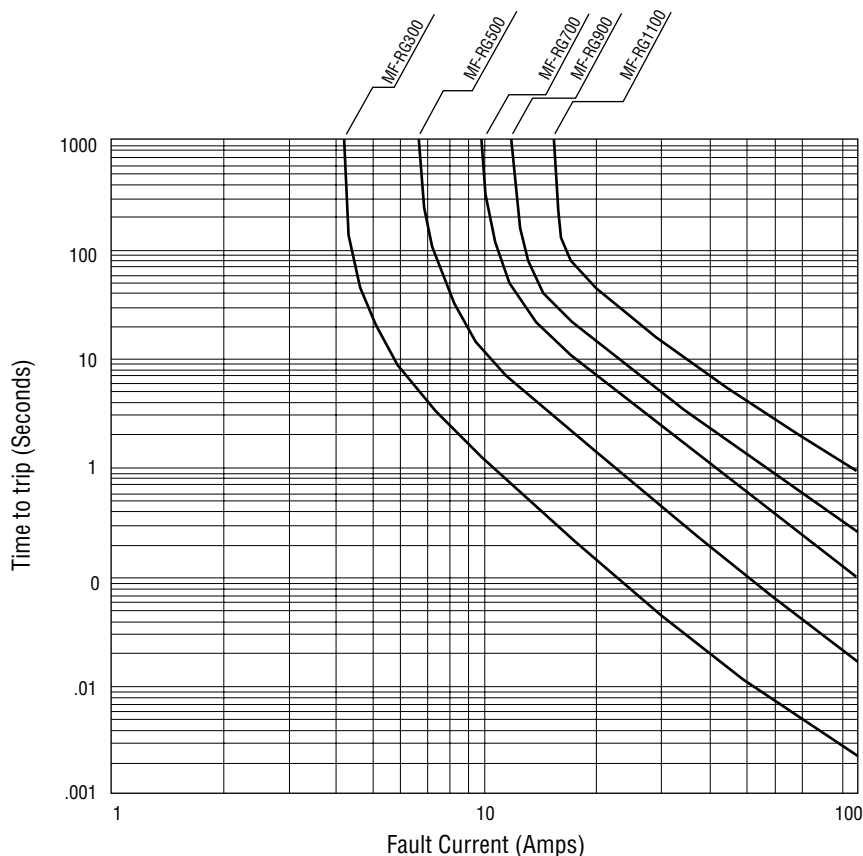

## Typical Part Marking

Represents total content. Layout may vary.

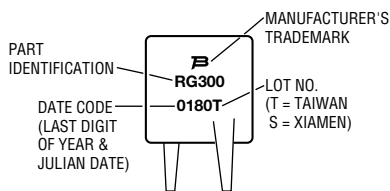

## How to Order

**MF - RG 300 -**

Multifuse® Product Designator

Series **RG** = Radial Ledged Component

Hold Current, Ihold  
300-1100 (300m Amps - 11.0 Amps)

Packaging Options  
 - **\_** = Bulk Packaging  
 - **2** = Tape and Reel\*  
 - **AP** = Ammo-Pak\*

\*Packaged per EIA486-B

Specifications are subject to change without notice.

MF-RG, REV. A, 12/00

# Tape and Reel Specifications

## MF-R, MF-RX, MF-RG & MF-R/250 Series Tape and Reel Specs

**BOURNS®**

Devices taped using EIA468-B/IEC286-2 standards. See table below and Figures 1 and 2 for details.

Dimension Description	IEC Mark	EIA Mark	Dimensions	
			Dimensions	Tolerance
Carrier tape width	<i>W</i>	<i>W</i>	$\frac{18}{(.709)}$	$\frac{-0.5/+1.0}{(-0.02/+0.039)}$
Hold down tape width		<i>W4</i>	$\frac{5}{(.197)}$	min.
Hold down tape	<i>W0</i>		No protrusion	
Top distance between tape edges	<i>W2</i>	<i>W6</i>	$\frac{3}{(.118)}$	max.
Sprocket hole position	<i>W1</i>	<i>W5</i>	$\frac{9}{(.354)}$	$\frac{-0.5/+0.75}{(-0.02/+0.03)}$
Sprocket hole diameter	<i>D0</i>	<i>D0</i>	$\frac{4}{(.157)}$	$\frac{\pm 0.2}{(\pm .0078)}$
Abscissa to plane (straight lead)	<i>H</i>	<i>H</i>	$\frac{18.5}{(.728)}$	$\frac{\pm 3.0}{(\pm .118)}$
Abscissa to plane (kinked lead)	<i>H0</i>	<i>H0</i>	$\frac{16}{(.63)}$	$\frac{\pm 0.5}{(\pm .02)}$
Abscissa to top	<i>H1</i>	<i>H1</i>	$\frac{32.2}{(1.268)}$	max.
Overall width w/lead protrusion		<i>C1</i>	$\frac{43.2}{(1.7)}$	max.
Overall width w/o lead protrusion		<i>C2</i>	$\frac{42.5}{(1.673)}$	max.
Lead protrusion	<i>I1</i>	<i>L1</i>	$\frac{1.0}{(.039)}$	max.
Protrusion of cutout	<i>L</i>	<i>L</i>	$\frac{11}{(.433)}$	max.
Protrusion beyond hold tape	<i>I2</i>	<i>I2</i>	Not specified	
Sprocket hole pitch	<i>P0</i>	<i>P0</i>	$\frac{12.7}{(0.5)}$	$\frac{\pm 0.3}{(\pm .012)}$
Pitch tolerance			20 seconds	$\pm 1$ second
Device pitch: MF-R010 – MF-R160			$\frac{12.7}{(0.5)}$	
Device pitch: MF-R185 – MF-R400			$\frac{25.4}{(1.0)}$	
Device pitch: MF-RX110 – MF-RX160			$\frac{12.7}{(0.5)}$	
Device pitch: MF-RX185 – MF-RX375			$\frac{12.7}{(0.5)}$	
Device pitch: MF-RG300, MF-RG500			$\frac{12.7}{(0.5)}$	
Device pitch: MF-RG700, MF-RG900, MF-RG1100			$\frac{25.4}{(1.0)}$	
Device pitch: MF-R012/250			$\frac{25.4}{(1.0)}$	
Tape thickness	<i>t</i>	<i>t</i>	$\frac{0.9}{(.035)}$	max.
Tape thickness with splice		<i>t1</i>	$\frac{2.0}{(.079)}$	max.
Splice sprocket hole alignment			0	$\frac{\pm 0.3}{(\pm .012)}$
Body lateral deviation	$\Delta h$	$\Delta h$	0	$\frac{\pm 1.0}{(\pm .039)}$
Body tape plane deviation	$\Delta p$	$\Delta p$	0	$\frac{\pm 1.3}{(\pm .051)}$
Lead seating plane deviation	$\Delta P1$	<i>P1</i>	0	$\frac{\pm 0.7}{(\pm .028)}$
Lead spacing	<i>F</i>	<i>F</i>	$\frac{5.08}{(0.2)}$	$\frac{\pm 0.8}{(\pm .035)}$
Reel width	<i>w</i>	<i>w</i>	$\frac{56}{(2.205)}$	max.
Reel diameter	<i>d</i>	<i>a</i>	$\frac{370}{(14.57)}$	max.
Space between flanges less device			$\frac{4.75}{(.187)}$	$\frac{\pm 3.25}{(\pm .128)}$

$$\text{DIMENSIONS} = \frac{\text{MM}}{(\text{INCHES})}$$

Specifications are subject to change without notice.

Dimension Description	IEC Mark	EIA Mark	Dimensions	
			Dimensions	Tolerance
Space between flanges less device			$\frac{4.75}{(.187)}$	$\frac{\pm 3.25}{(\pm .128)}$
Arbor hole diameter	<i>f</i>	<i>c</i>	$\frac{26}{(1.024)}$	$\frac{\pm 12.0}{(\pm .472)}$
Core diameter	<i>h</i>	<i>n</i>	$\frac{80}{(3.15)}$	max.
Box			$\frac{56}{(2.2)}$ $\frac{372}{(14.6)}$ $\frac{372}{(14.6)}$	max.
Consecutive missing places			3 maximum	
Empty places per reel			Not specified	

DIMENSIONS =  $\frac{\text{MM}}{\text{(INCHES)}}$

**Taped Component Dimensions**

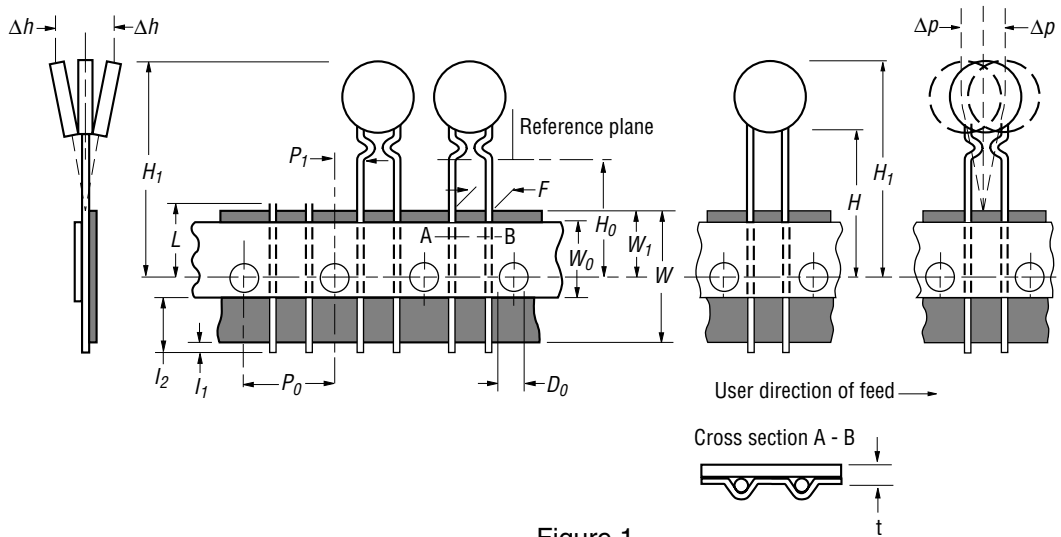

Figure 1

**Reel Dimensions**

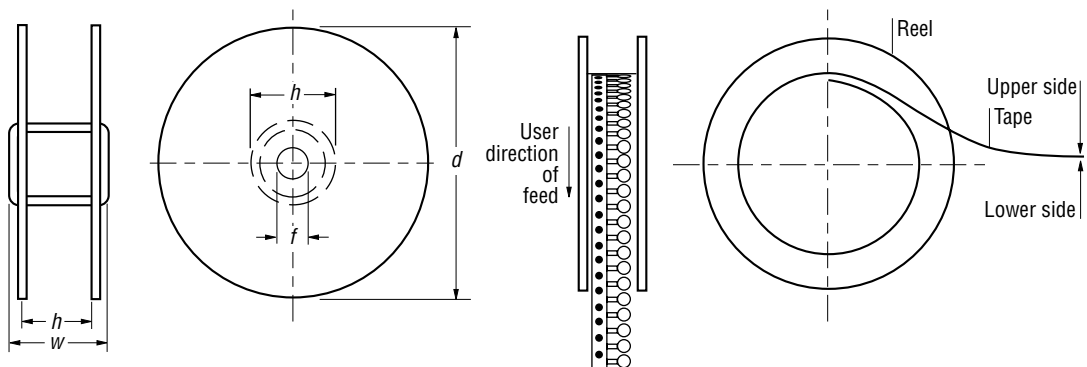
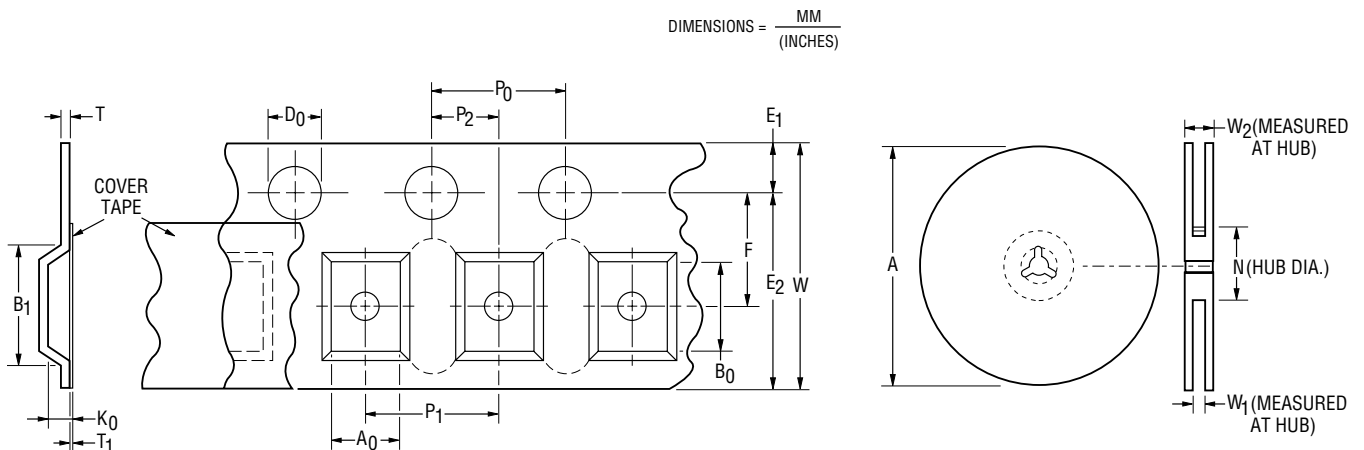

Figure 2

# MF-SM Series Tape and Reel Specifications



Tape Dimension Identifiers	MF-SM030, 050, 075, 100, 125 per EIA-481-2	MF-SM150, 200, 250, 260 per EIA 481-2
W	$\frac{16 \pm 0.3}{(63 \pm .012)}$	$\frac{16 \pm 0.3}{(63 \pm .012)}$
P <sub>0</sub>	$\frac{4.0 \pm 0.10}{(.157 \pm .004)}$	$\frac{4.0 \pm 0.10}{(.157 \pm .004)}$
P <sub>1</sub>	$\frac{8.0 \pm 0.10}{(.315 \pm .004)}$	$\frac{12.0 \pm 0.10}{(.472 \pm .004)}$
P <sub>2</sub>	$\frac{8.0 \pm 0.10}{(.315 \pm .004)}$	$\frac{12.0 \pm 0.10}{(.472 \pm .004)}$
A <sub>0</sub>	$\frac{2.0 \pm 0.10}{(.079 \pm .004)}$	$\frac{2.0 \pm 0.10}{(.079 \pm .004)}$
B <sub>0</sub>	$\frac{5.7 \pm 0.10}{(.224 \pm .004)}$	$\frac{6.9 \pm 0.10}{(.272 \pm .004)}$
B <sub>1</sub> max.	$\frac{8.1 \pm 0.15}{(.319 \pm .006)}$	$\frac{9.6 \pm 0.10}{(.378 \pm .004)}$
D <sub>0</sub>	$\frac{9.1}{(.358)}$	$\frac{11.0}{(.433)}$
F	$\frac{1.5 + 0.1/-0}{(.059 + .004/-0)}$	$\frac{1.5 + 0.1/-0}{(.059 + .004/-0)}$
E <sub>1</sub>	$\frac{7.5 \pm 0.10}{(.295 \pm .004)}$	$\frac{7.5 \pm 0.10}{(.295 \pm .004)}$
E <sub>2</sub> min.	$\frac{1.75 \pm 0.10}{(.069 \pm .004)}$	$\frac{1.75 \pm 0.10}{(.069 \pm .004)}$
T max.	$\frac{14.25}{(.561)}$	$\frac{14.25}{(.561)}$
T <sub>1</sub> max.	$\frac{0.4}{(.016)}$	$\frac{0.4}{(.016)}$
K <sub>0</sub>	$\frac{0.1}{(.004)}$	$\frac{0.1}{(.004)}$
Leader min.	$\frac{3.4 \pm 0.15}{(.134 \pm .006)}$	$\frac{3.5 \pm 0.15}{(.138 \pm .006)}$
Trailer min.	$\frac{390}{(15.35)}$	$\frac{390}{(15.35)}$
<b>Reel Dimension Identifiers</b>	$\frac{160}{(6.30)}$	$\frac{160}{(6.30)}$
A max.	$\frac{360}{(14.17)}$	$\frac{360}{(14.17)}$
N min.	$\frac{50}{(1.97)}$	$\frac{50}{(1.97)}$
W <sub>1</sub>	$\frac{16.4 + 2.0/-0}{(.65 + .079/-0)}$	$\frac{16.4 + 2.0/-0}{(.65 + .079/-0)}$
W <sub>2</sub> max.	$\frac{22.4}{(.882)}$	$\frac{22.4}{(.882)}$



# MF-MSMD, MF-USMD & MF-ESMD Series Tape and Reel Specs



Tape Dimension Identifiers	MF-MSMD Series per EIA-481-1	MF-USMD Series per EIA 481-1	MF-ESMD Series per EIA 481-1
W	$\frac{12 \pm 0.3}{(.472 \pm .012)}$	$\frac{8 \pm 0.3}{(.040 \pm .012)}$	$\frac{8 \pm 0.3}{(.040 \pm .012)}$
P <sub>0</sub>	$\frac{4.0 \pm 0.10}{(.157 \pm .004)}$	$\frac{4.0 \pm 0.10}{(.157 \pm .004)}$	$\frac{4.0 \pm 0.10}{(.157 \pm .004)}$
P <sub>1</sub>	$\frac{8.0 \pm 0.10}{(.315 \pm .004)}$	$\frac{4.0 \pm 0.10}{(.157 \pm .004)}$	$\frac{4.0 \pm 0.10}{(.157 \pm .004)}$
P <sub>2</sub>	$\frac{2.0 \pm 0.05}{(.079 \pm .039)}$	$\frac{2.0 \pm 0.05}{(.079 \pm .039)}$	$\frac{2.0 \pm 0.05}{(.079 \pm .039)}$
A <sub>0</sub>	$\frac{3.5 \pm 0.23}{(.134 \pm .009)}$	$\frac{2.8 \pm 0.1}{(.110 \pm .004)}$	$\frac{2.8 \pm 0.1}{(.110 \pm .004)}$
B <sub>0</sub>	$\frac{5.1 \pm 0.15}{(.201 \pm .006)}$	$\frac{3.5 \pm 0.1}{(.138 \pm .004)}$	$\frac{3.5 \pm 0.1}{(.138 \pm .004)}$
B <sub>1</sub> max.	$\frac{5.9}{(.232)}$	$\frac{4.35}{(.171)}$	$\frac{4.35}{(.171)}$
D <sub>0</sub>	$\frac{1.5 + 0.1/-0}{(.059 + .004/-0)}$	$\frac{1.5 + 0.1/-0}{(.059 + .004/-0)}$	$\frac{1.5 + 0.1/-0}{(.059 + .004/-0)}$
F	$\frac{5.5 \pm 0.05}{(2.165 \pm .002)}$	$\frac{3.5 \pm 0.05}{(.138 \pm .002)}$	$\frac{3.5 \pm 0.05}{(.138 \pm .002)}$
E <sub>1</sub>	$\frac{1.75 \pm 0.10}{(.069 \pm .004)}$	$\frac{1.75 \pm 0.10}{(.069 \pm .004)}$	$\frac{1.75 \pm 0.10}{(.069 \pm .004)}$
E <sub>2</sub> min.	$\frac{10.25}{(.404)}$	$\frac{6.25}{(.246)}$	$\frac{6.25}{(.246)}$
T max.	$\frac{0.6}{(.024)}$	$\frac{0.6}{(.024)}$	$\frac{0.6}{(.024)}$
T <sub>1</sub> max.	$\frac{0.1}{(.004)}$	$\frac{0.1}{(.004)}$	$\frac{0.1}{(.004)}$
K <sub>0</sub>	$\frac{0.9 \pm 0.15}{(.035 \pm .006)}$	$\frac{1.1 \pm 0.05}{(.043 \pm .002)}$	$\frac{0.8 \pm 0.1}{(.031 \pm .004)}$
Leader min.	$\frac{390}{(15.35)}$	$\frac{390}{(15.35)}$	$\frac{390}{(15.35)}$
Trailer min.	$\frac{160}{(6.30)}$	$\frac{160}{(6.30)}$	$\frac{160}{(6.30)}$
<b>Reel Dimension Identifiers</b>			
A max.	$\frac{185}{(7.283)}$	$\frac{185}{(7.283)}$	$\frac{185}{(7.283)}$
N min.	$\frac{50}{(1.97)}$	$\frac{50}{(1.97)}$	$\frac{50}{(1.97)}$
W <sub>1</sub>	$\frac{12.4 + 2.0/-0}{(.488 + .075/-0)}$	$\frac{8.4 + 1.5/-0}{(.331 + .059/-0)}$	$\frac{8.4 + 1.5/-0}{(.331 + .059/-0)}$
W <sub>2</sub> max.	$\frac{18.4}{(.724)}$	$\frac{14.4}{(.567)}$	$\frac{14.4}{(.567)}$

DIMENSIONS =  $\frac{\text{MM}}{\text{(INCHES)}}$

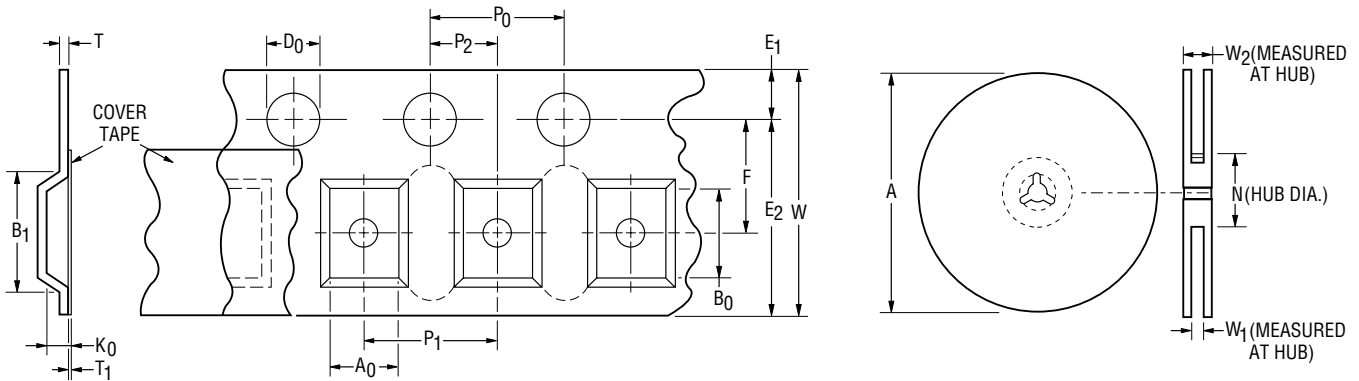

# MF-SM013/250 Series Tape and Reel Specifications



## Taped Component Dimensions

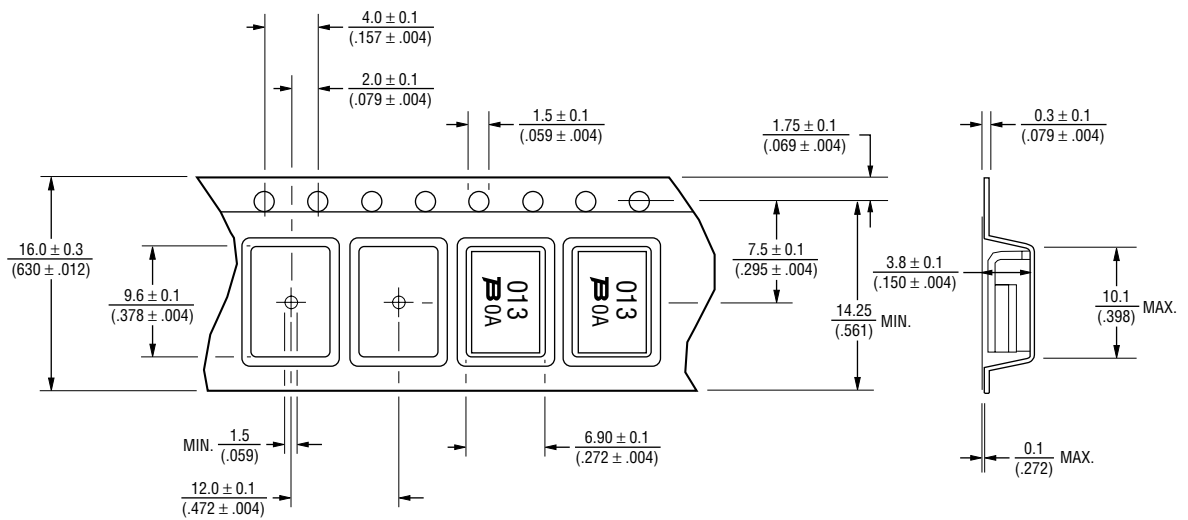

## Reel Dimensions

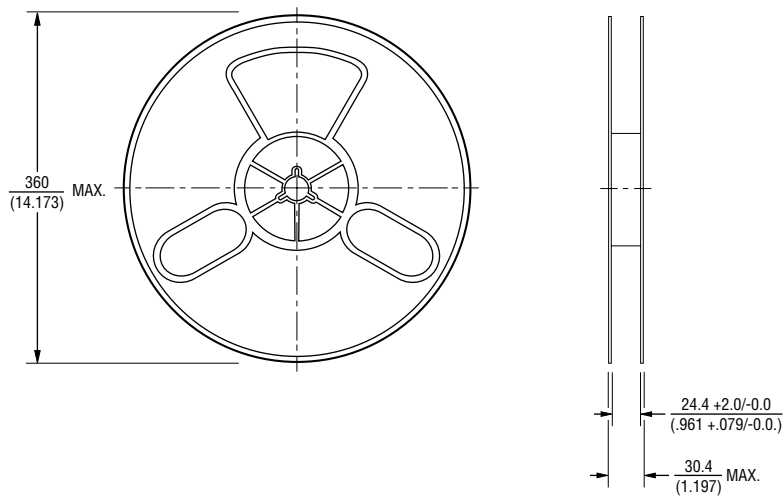

# MF-S, MF-LS, MF-LR and MF-VS Series Tape and Reel Specifications **BOURNS**<sup>®</sup>

## Taped Component Dimensions

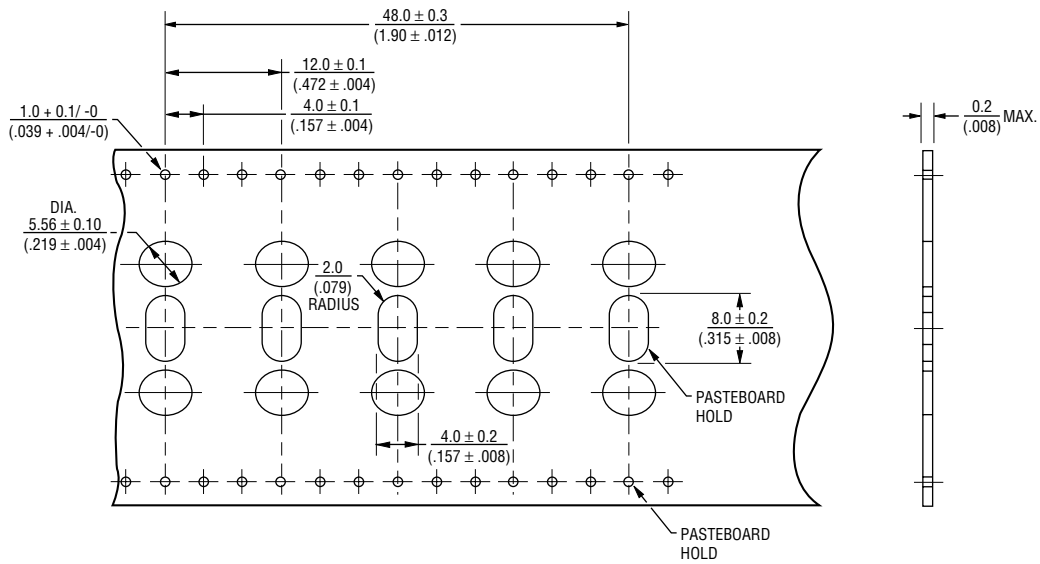

## Reel Dimensions

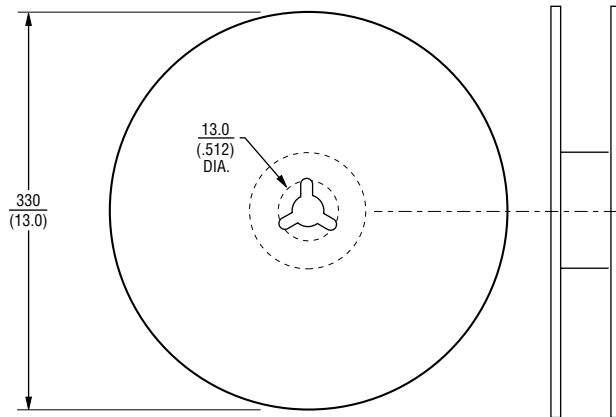

## Taped Component Dimensions

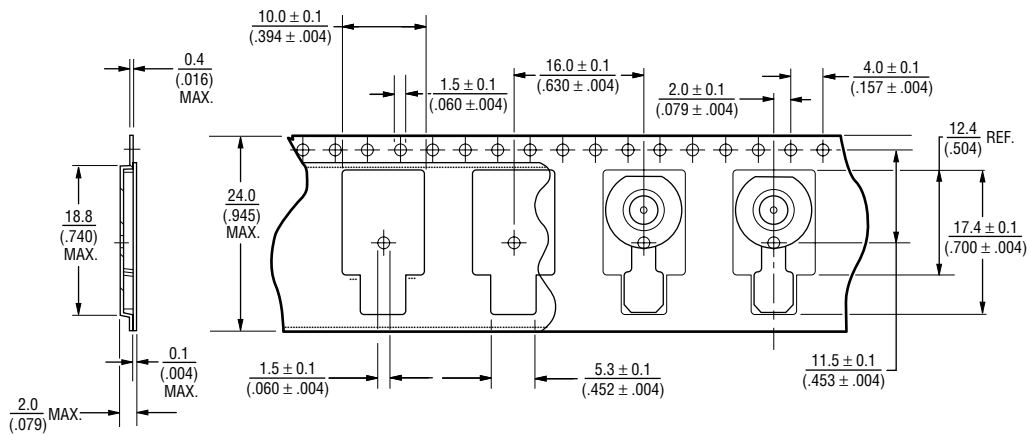

## Reel Dimensions

