

June 1995

DESCRIPTION

The SSI 73K324L is a highly integrated single-chip modem IC which provides the functions needed to design a Quad-mode CCITT and Bell 212A compatible modem capable of operation over dial-up lines. The SSI 73K324L adds V.23 capability to the CCITT modes of Silicon Systems' 73K224 one-chip modem, allowing a one-chip implementation in designs intended for European markets which require this added Modulation mode. The SSI 73K324L offers excellent performance and a high level of functional integration in a single IC. The device supports V.22bis, V.22, Bell 212A, V.21, and V.23 operating modes, allowing both synchronous and asynchronous operation as defined by the appropriate standard.

The SSI 73K324L is designed to appear to the Systems Engineer as a microprocessor peripheral, and will easily interface with popular one-chip microcontrollers (80C51 typical) for control of modem functions through its 8-bit multiplexed address/data bus. A serial control bus is available for applications not requiring a parallel interface. An optional package with only the serial control bus is also available. Data communications occurs through a separate serial port.

(continued)

FEATURES

- One chip Multi-mode CCITT V.22bis, V.22, V.21, V.23 and Bell 212A compatible modem data pump
- FSK (75, 300, 1200 bit/s), DPSK (600, 1200 bit/s), or QAM (2400 bit/s) encoding
- Pin and software compatible with other SSI K-Series family one-chip modems
- Interfaces directly with standard microprocessors (8048, 80C51 typical)
- Serial and parallel microprocessor bus for control
- Selectable asynch/synch with internal buffer/debuffer and scrambler/descrambler functions
- All synchronous (internal, external, slave) and Asynchronous Operating modes
- Adaptive equalization for optimum performance over all lines
- Programmable transmit attenuation (16 dB, 1 dB steps), and selectable receive boost (+18 dB)
- Call progress, carrier, answer tone, unscrambled mark, S1, and signal quality monitors
- DTMF, answer, calling, SCT and guard tone generators
- Test modes available: ALB, DL, RDL; Mark, Space and Alternating bit pattern generators
- CMOS technology for low power consumption
- 4-wire full duplex operation in all modes

BLOCK DIAGRAM

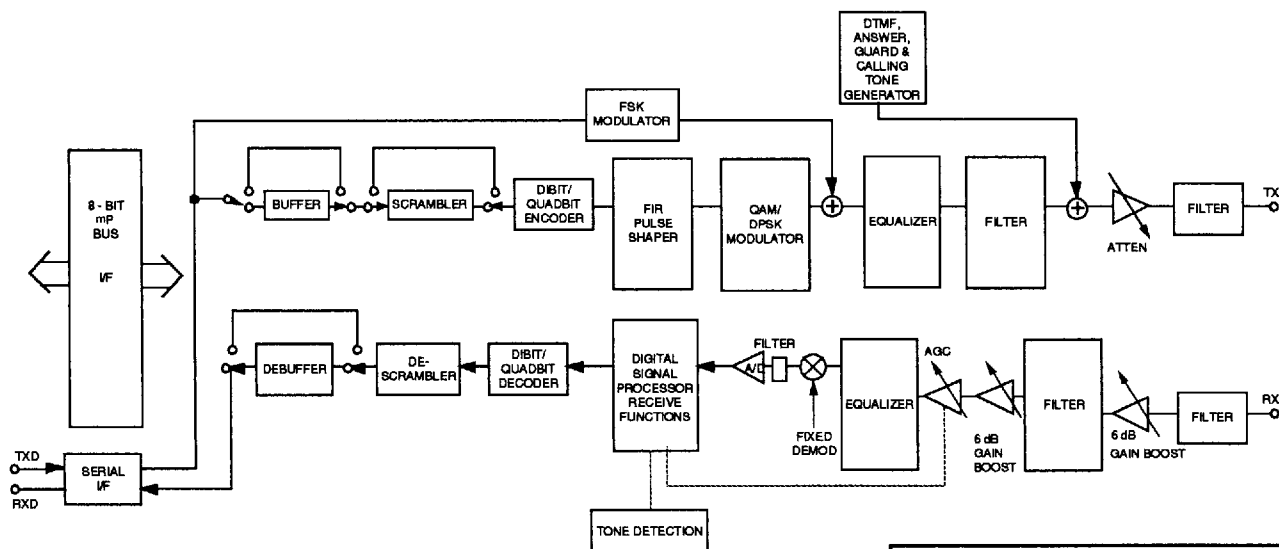

CAUTION: Use handling procedures necessary for a static sensitive component.

SSI 73K324L

CCITT V.22bis, V.22, V.21, V.23, Bell 212A

Single-Chip Modem

DESCRIPTION (continued)

The SSI 73K324L offers full hardware and software compatibility with other products in Silicon Systems' K-Series family of single-chip modems, allowing system upgrades with a single component change. The SSI 73K324L is ideal for use in free-standing or integral system modem products where full-duplex 2400 bit/s operation with Alternate mode capability is required. Its high functionality, low power consumption, and efficient packaging simplify design requirements and increase system reliability. A complete modem requires only the addition of the phone line interface, a control microprocessor, and RS-232 level converters for a typical system.

The SSI 73K324L is designed to provide a complete V.22bis, V.22, Bell 212A, V.21, and V.23 compatible modem on a chip. Many functions were included to simplify implementation in typical modem designs. In addition to the basic 2400 bit/s QAM, 1200/600 bit/s DPSK and 1200/300/75 bit/s FSK modulator/demodulator sections, the device also includes synch/asynch buffering, DTMF, answer, soft carrier, guard, and calling tone generator capabilities. Handshake pattern detectors simplify control of connect sequences, and precise tone detectors allow accurate detection of call progress, answer, calling, and soft carrier turn off tones. All Operating modes defined by the incorporated standards are included, and Test modes are provided. Most functions are selectable as options, and logical defaults are provided. The device can be directly interfaced to a microprocessor via its 8-bit multiplexed address/data bus for control and status monitoring. Data communications takes place through a separate serial port. Data may also be sent and received through the control registers. This simplifies designs requiring speed buffering, error control and compression.

FUNCTIONAL DESCRIPTION

QAM MODULATOR/DEMODULATOR

The SSI 73K324L encodes incoming data into quadrants represented by 16 possible signal points with specific phase and amplitude levels. The baseband signal is then filtered to reduce intersymbol interference on the bandlimited telephone network. The modulator transmits this encoded data using either a 1200 Hz (Originate mode) or 2400 Hz (Answer mode) carrier. The demodulator, although more complex,

essentially reverses this procedure while also recovering the data clock from the incoming signal. Adaptive equalization corrects for varying line conditions by automatically changing filter parameters to compensate for line characteristics.

DPSK MODULATOR/DEMODULATOR

The SSI 73K324L modulates a serial bit stream into di-bit pairs that are represented by four possible phase shifts as prescribed by the Bell 212A/V.22 standards. The baseband signal is then filtered to reduce intersymbol interference on the bandlimited 2-wire PSTN line. Transmission occurs on either a 1200 Hz (Originate mode) or 2400 Hz carrier (Answer mode). Demodulation is the reverse of the modulation process, with the incoming analog signal eventually decoded into di-bits and converted back to a serial bit stream. The demodulator also recovers the clock which was encoded into the analog signal during modulation. Demodulation occurs using either a 1200 Hz carrier (Answer mode or ALB Originate mode) or a 2400 Hz carrier (Originate mode or ALB Answer mode). The SSI 73K324L use a phase locked loop coherent demodulation technique that offers excellent performance. Adaptive equalization is also used in DPSK modes for optimum operation with varying lines.

FSK MODULATOR/DEMODULATOR

The FSK modulator/demodulator produces a frequency modulated analog output signal using two discrete frequencies to represent the binary data. V.21 frequencies of 980 and 1180 Hz (originate mark and space), or 1650 and 1850 Hz (answer mark and space) are used in V.21 mode. V.23 mode uses 1300 and 2100 Hz for the main channel or 390 and 450 Hz for the back channel. Demodulation involves detecting the received frequencies and decoding them into the appropriate binary value. The rate converter and scrambler/descrambler are automatically bypassed in the FSK modes.

PASSBAND FILTERS AND EQUALIZERS

High and low band filters are included to shape the amplitude and phase response of the transmit and receive signals and to provide compromise delay equalization as well as rejection of out-of-band signals. The transmit signal filtering corresponds to a $\sqrt{75\%}$ raised cosine frequency response characteristic.

SSI 73K324L CCITT V.22bis, V.22, V.21, V.23, Bell 212A Single-Chip Modem

ASYNCHRONOUS MODE

The Asynchronous mode is used for communication with asynchronous terminals which may transfer data at 600, 1200, or 2400 bit/s $\pm 1\%$, -2.5% even though the modem's output is limited to the nominal bit rate $\pm 0.01\%$ in DPSK and QAM modes. When transmitting in this mode the serial data on the TxD input is passed through a rate converter which inserts or deletes stop bits in the serial bit stream in order to output a signal that is the nominal bit rate $\pm 0.01\%$. This signal is then routed to a data scrambler and into the analog modulator where di-bit or quad-bit encoding results in the output signal. Both the rate converter and scrambler can be bypassed for handshaking and synchronous operation as selected. Received data is processed in a similar fashion except that the rate converter now acts to reinsert any deleted stop bits and output data to the terminal at no greater than the bit rate plus 1%. An incoming break signal (low through two characters) will be recognized and passed through without incorrectly inserting a stop bit.

The SYNC/ASYNC converter has an extended Overspeed mode which allows selection of an output speed range of either $+1\%$ or $+2.3\%$. In the extended Overspeed mode, some stop bits are output at $7/8$ the normal width.

Both the SYNC/ASYNC rate converter and the data descrambler are automatically bypassed in the FSK modes.

SYNCHRONOUS MODE

Synchronous operation is possible only in the QAM or DPSK modes. Operation is similar to that of the Asynchronous mode except that data must be synchronized to a clock and no variation in data transfer rate is allowable. Serial input data appearing at TXD must be valid on the rising edge of TXCLK.

TXCLK is an internally derived 1200 or 2400 Hz signal in Internal mode and is connected internally to the RXCLK pin in Slave mode. Receive data at the RXD pin is clocked out on the falling edge of RXCLK. The asynch/synch converter is bypassed when Synchronous mode is selected and data is transmitted out at essentially the same rate as it is input.

PARALLEL CONTROL INTERFACE

Eight 8-bit registers are provided for control, option select, and status monitoring. These registers are addressed with the AD0, AD1, and AD2 multiplexed address lines (latched by ALE) and appear to a control microprocessor as seven consecutive memory locations. Six control registers are read/write. The detect and ID registers are read only and cannot be modified except by modem response to monitored parameters.

SERIAL CONTROL INTERFACE

The Serial Command mode allows access to the SSI 73K324L control and status registers via a serial control port. In this mode the A0, A1, and A2 lines provide register addresses for data passed through the DATA pin under control of the \overline{RD} and \overline{WR} lines. A read operation is initiated when the \overline{RD} line is taken low. The next eight cycles of EXCLK will then transfer out eight bits of the selected address location LSB first. A write takes place by shifting in eight bits of data LSB first for eight consecutive cycles of EXCLK. \overline{WR} is then pulsed low and data transfer into the selected register occurs on the rising edge of \overline{WR} .

-tone generator

The DTMF generator controls the sending of the sixteen standard DTMF tone pairs. The tone pair sent is determined by selecting TRANSMIT DTMF (bit D4) and the 4 DTMF bits (D0-D3) of the TONE register. Transmission of DTMF tones from TXA is gated by the TRANSMIT ENABLE bit of CR0 (bit D1) as with all other analog signals.

FULL DUPLEX OPERATION

Four-wire full duplex operation is allowed in all modes. This feature allows transmission and reception in the same band for four wire applications only.

SSI 73K324L

CCITT V.22bis, V.22, V.21, V.23, Bell 212A

Single-Chip Modem

PIN DESCRIPTION

POWER

NAME	TYPE	DESCRIPTION
GND	I	System Ground.
VDD	I	Power supply input, 5V -5% +10%. Bypass with 0.22 μ F and 22 μ F capacitors to GND.
VREF	O	An internally generated reference voltage. Bypass with 0.22 μ F capacitor to GND.
ISET	I	Chip current reference. Sets bias current for op-amps. The chip current is set by connecting this pin to VDD through a 2 M Ω resistor. Iset should be bypassed to GND with a 0.22 μ F capacitor.

PARALLEL MICROPROCESSOR INTERFACE

ALE	I	Address latch enable. The falling edge of ALE latches the address on AD0-AD2 and the chip select on \overline{CS} .
AD0-AD7	I/O / Tristate	Address/data bus. These bidirectional tri-state multi-plexed lines carry information to and from the internal registers.
\overline{CS}	I	Chip select. A low on this pin allows a read cycle or a write cycle to occur. AD0-AD7 will not be driven and no registers will be written if \overline{CS} (latched) is not active. \overline{CS} is latched on the falling edge of ALE.
CLK	O	Output clock. This pin is selectable under processor control to be either the crystal frequency (for use as a processor clock) or 16 x the data rate for use as a baud rate clock in QAM/DPSK modes only. The pin defaults to the crystal frequency on reset.
\overline{INT}	O	Interrupt. This open drain weak pullup, output signal is used to inform the processor that a detect flag has occurred. The processor must then read the detect register to determine which detect triggered the interrupt. \overline{INT} will stay active until the processor reads the detect register or does a full reset.
\overline{RD}	I	Read. A low requests a read of the SSI 73K324L internal registers. Data cannot be output unless both \overline{RD} and the latched \overline{CS} are active or low.
RESET	I	Reset. An active high signal on this pin will put the chip into an inactive state. All control register bits (CR0, CR1, CR2, CR3, Tone) will be reset. The output of the CLK pin will be set to the crystal frequency. An internal pull down resistor permits power on reset using a capacitor to VDD.
\overline{WR}	I	Write. A low on this informs the SSI 73K324L that data is available on AD0-AD7 for writing into an internal register. Data is latched on the rising edge of \overline{WR} . No data is written unless both \overline{WR} and the latched \overline{CS} are low.

Note: The Serial Control mode is provided in the parallel versions by tying ALE high and \overline{CS} low. In this configuration AD7 becomes DATA and AD0, AD1 and AD2 become A0, A1 and A2, respectively.

SSI 73K324L
CCITT V.22bis, V.22, V.21, V.23, Bell 212A
Single-Chip Modem

RS-232 INTERFACE

NAME	TYPE	DESCRIPTION
EXCLK	I	External Clock. This signal is used in synchronous transmission when the external timing option has been selected. In the External Timing mode the rising edge of EXCLK is used to strobe synchronous transmit data available on the TXD pin. Also used for serial control interface.
RXCLK	O/Tristate	Receive Clock Tri-statable. The falling edge of this clock output is coincident with the transitions in the serial received DPSK/QAM data output. The rising edge of RXCLK can be used to latch the valid output data. RXCLK will be valid as long as a carrier is present. In V.23 or V.21 mode a clock which is 16 x 1200/75 or 16 x 300 Hz data rate is output, respectively.
RXD	O/ Weak Pull-up	Received Data Output. Serial receive data is available on this pin. The data is always valid on the rising edge of RXCLK when in Synchronous mode. RXD will output constant marks if no carrier is detected.
TXCLK	O/Tristate	Transmit Clock Tri-statable. This signal is used in synchronous DPSK/QAM transmission to latch serial input data on the TXD pin. Data must be provided so that valid data is available on the rising edge of the TXCLK. The transmit clock is derived from different sources depending upon the Synchronization mode selection. In Internal Mode the clock is generated internally (2400 Hz for QAM, 1200 Hz for DPSK or 600 Hz for half-speed DPSK). In External Mode TXCLK is phase locked to the EXCLK pin. In Slave Mode TXCLK is phase locked to the RXCLK pin. TXCLK is always active. In V.23 or V.21 mode the output is a 16 x 1200/75 or 16 x 300 Hz clock, respectively.
TXD	I	Transmit Data Input. Serial data for transmission is input on this pin. In Synchronous modes, the data must be valid on the rising edge of the TXCLK clock. In Asynchronous modes (2400/1200/600 bit/s, or 75/300 baud) no clocking is necessary. DPSK/QAM data must be +1%, -2.5% or +2.3%, -2.5 % in Extended Overspeed mode.

ANALOG INTERFACE

RXA	I	Received modulated analog signal input from the phone line.
TXA	O	Transmit analog output to the phone line.
XTL1	I	These pins are for the internal crystal oscillator requiring a 11.0592 MHz Parallel mode crystal. Two capacitors from these pins to ground are also required for proper crystal operation. Consult crystal manufacturer for proper values. XTL2 can also be driven from an external clock.
XTL2	I/O	

SSI 73K324L
CCITT V.22bis, V.22, V.21, V.23, Bell 212A
Single-Chip Modem

PIN DESCRIPTION (continued)

SERIAL MICROPROCESSOR INTERFACE

NAME	TYPE	DESCRIPTION
A0-A2	I	Register Address Selection. These lines carry register addresses and should be valid during any read or write operation.
DATA	I/O	Serial Control Data. Data for a read/write operation is clocked in or out on the falling edge of the EXCLK pin. The direction of data flow is controlled by the \overline{RD} pin. \overline{RD} low outputs data. \overline{RD} high inputs data.
\overline{RD}	I	Read. A low on this input informs the SSI 73K324L that data or status information is being read by the processor. The falling edge of the \overline{RD} signal will initiate a read from the addressed register. The \overline{RD} signal must continue for eight falling edges of EXCLK in order to read all eight bits of the referenced register. Read data is provided LSB first. Data will not be output unless the \overline{RD} signal is active.
\overline{WR}	I	Write. A low on this input informs the SSI 73K324L that data or status information has been shifted in through the DATA pin and is available for writing to an internal register. The normal procedure for a write is to shift in data LSB first on the DATA pin for eight consecutive falling edges of EXCLK and then to pulse \overline{WR} low. Data is written on the rising edge of \overline{WR} .

Note: In the serial, 22-pin version, the pins AD0-AD7, ALE and \overline{CS} are removed and replaced with the pins; A0, A1, A2, DATA, and EXCLK. Also, the \overline{RD} and \overline{WR} controls are used differently.

SSI 73K324L

CCITT V.22bis, V.22, V.21, V.23, Bell 212A

Single-Chip Modem

REGISTER DESCRIPTIONS

Eight 8-bit internal registers are accessible for control and status monitoring. The registers are accessed in read or write operations by addressing the A0, A1 and A2 address lines in Serial mode, or the AD0, AD1 and AD2 lines in Parallel mode. The address lines are latched by ALE. Register CR0 controls the method by which data is transferred over the phone line. CR1 controls the interface between the microprocessor and

the SSI 73K324L internal state. DR is a detect register which provides an indication of monitored modem status conditions. TR, the tone control register, controls the DTMF generator, answer, guard tones, SCT, calling tone, and RXD output gate used in the modem initial connect sequence. CR2 is the primary DSP control interface and CR3 controls transmit attenuation and receive gain adjustments. All registers are read/write except for DR and ID which are read only. Register control and status bits are identified below:

REGISTER BIT SUMMARY

REGISTER	ADDRESS		DATA BIT NUMBER							
	AD - A0		D7	D6	D5	D4	D3	D2	D1	D0
CONTROL REGISTER 0 CR0	000		MODULATION OPTION	MODULATION TYPE 1	MODULATION TYPE 0	TRANSMIT MODE 2	TRANSMIT MODE 1	TRANSMIT MODE 0	TRANSMIT ENABLE	ANSWER/ORIGINATE
CONTROL REGISTER 1 CR1	001		TRANSMIT PATTERN 1	TRANSMIT PATTERN 0	ENABLE DETECT INTERRUPT	BYPASS SCRAMBLER/ADD PH. EQ. (V.23)	CLK CONTROL	RESET	TEST MODE 1	TEST MODE 0
DETECT REGISTER DR	010		RECEIVE LEVEL	PATTERN S1 DET	RECEIVE DATA	UNSCR. MARK DETECT	CARRIER DETECT	SPECIAL TONE DETECT	CALL PROGRESS DETECT	SIGNAL QUALITY
tone CONTROL REGISTER TR	011		RXD OUTPUT CONTROL	TRANSMIT GUARD TONE/SCT/CALLING TONE	TRANSMIT ANSWER TONE	TRANSMIT DTMF	DTMF3	DTMF2/4 WIRE FDX	DTMF1/OVERSPEED	DTMF0/GUARD/ANSWER/CALLING/SCT
CONTROL REGISTER 2 CR2	100	0	SPECIAL REGISTER ACCESS	CALL INITIALIZE		TRANSMIT S1	16 WAY	RESET DSP	TRAIN INHIBIT	EQUALIZER ENABLE
CONTROL REGISTER 3 CR3	101		TXDALT	TRISTATE TX/RXCLK	0	RECEIVE GAIN BOOST	TRANSMIT ATTEN. 3	TRANSMIT ATTEN. 2	TRANSMIT ATTEN. 1	TRANSMIT ATTEN. 0
SPECIAL REGISTER SR	101	0	TX BAUD CLOCK	RX UNSCR. DATA	0	TXD SOURCE	SQ SELECT 1	SQ SELECT 0	0	0
ID REGISTER ID	110		1	1	1	0	X	X	X	X

NOTE: When a register containing reserved control bits is written into, the reserved bits must be programmed as 0's.

X = Undefined, mask in software.

SSI 73K324L

CCITT V.22bis, V.22, V.21, V.23, Bell 212A

Single-Chip Modem

REGISTER ADDRESS TABLE

REGISTER	ADDRESS		DATA BIT NUMBER							
	AD2 - AD0	D7	D6	D5	D4	D3	D2	D1	D0	
CONTROL REGISTER 0	CR0	000	MODULATION OPTION	MODULATION TYPE 1	MODULATION TYPE 0	TRANSMIT MODE 2	TRANSMIT MODE 1	TRANSMIT MODE 0	TRANSMIT ENABLE	ANSWER/ORIGINATE
			QAM: 0=2400 BIT/S DPSK: 0=1200 BIT/S 1=600 BIT/S FSK: 0=V.23 1=V.21	10=QAM 00=DPSK 01=FSK	0000=PWR DOWN 0001=INT SYNCH 0010=EXT SYNCH 0011=SLAVE SYNCH 0100=ASYCH 8 BITS/CHAR 0101=ASYCH 9 BITS/CHAR 0110=ASYCH 10 BITS/CHAR 0111=ASYCH 11 BITS/CHAR 1X00=FSK				0=DISABLE TXA OUTPUT 1=ENABLE TXA OUTPUT	0=ANSWER 1=ORIGINATE in V.23 0=BC xmit 1=MC xmit
CONTROL REGISTER 1	CR1	001	TRANSMIT PATTERN 1	TRANSMIT PATTERN 0	ENABLE DETECT INTERRUPT	BYPASS SCRAMBLER/ADD PH. EQ. (V.23)	CLK CONTROL	RESET	TEST MODE 1	TEST MODE 0
			00=TX DATA 01=TX ALTERNATE 10=TX MARK 11=TX SPACE		0=OFF 1=ON	0=NORMAL 1=BYPASS SCRAMBLER	0=XTAL 1=16 X DATA RATE OUTPUT AT CLK PIN IN QAM/DPSK MODE ONLY	0=NORMAL 1=RESET	00=NORMAL 01=ANALOG LOOPBACK 10=REMOTE DIGITAL LOOPBACK 11=LOCAL DIGITAL LOOPBACK	
DETECT REGISTER	DR	010	RECEIVE LEVEL INDICATOR	S1 PATTERN DETECT	RECEIVE DATA	UNSCR. MARKS DETECT	CARRIER DETECT	SPECIAL TONE DETECT	CP TONE DETECT	SIGNAL QUALITY INDICATOR
			0=SIGNAL BELOW THRESHOLD 1=ABOVE THRESHOLD	0=NOT PRESENT 1=PATTERN FOUND	OUTPUTS RECEIVED DATA STREAM		0=CONDITION NOT DETECTED 1=CONDITION DETECTED			0=GOOD 1=BAD
tone CONTROL REGISTER	TR	011	RXD OUTPUT CONTROL	TRANSMIT GUARD/CALLING/SCT TONE	TRANSMIT ANSWER TONE	TRANSMIT DTMF	DTMF3	DTMF2/4 WIRE FDX	DTMF1/ OVERSPEED	DTMF0/ GUARD/ ANSWER/ CALLING/SCT
			RXD PIN 0=NORMAL 1=TRI-STATE	0=OFF 1=ON	0=OFF 1=ON	1=TX DTMF	4 BIT CODE FOR 1 OF 16 DUAL TONE COMBINATIONS 0=NORMAL OPERATION 1=ALLOWS V.23 FULL DUPLEX OPERATION			GUARD: 0 - 1800 HZ 1 - 550 HZ ANSWER: 0 - 2225 HZ 1 - 2100 HZ CALLING: 0 - 1300 HZ SCT: 1 - 900 HZ
CONTROL REGISTER 2	CR2	100	MUST BE 0	SPECIAL REGISTER ACCESS	CALL INITIALIZE	TRANSMIT S1	16 WAY	RESET DSP	TRAIN INHIBIT	EQUALIZER ENABLE
				0=ACCESS CR3 1=ACCESS SPECIAL REGISTER	0=DSP IN DEMOD MODE 1=DSP IN CALL PROGRESS MODE	0=NORMAL DOTTING 1=S1	0=RX=TX 1=RX=16 WAY	0=DSP INACTIVE 1=DSP ACTIVE	0=ADAPT EQ ACTIVE 1=ADAPT EQ FROZEN	0=ADAPT EQ IN INIT 1=ADAPT EQ OK TO ADAPT
CONTROL REGISTER 3	CR3	101	TXDALT	TRISTATE TX/RXCLK	0	RECEIVE GAIN BOOST	TRANSMIT ATTEN. 3	TRANSMIT ATTEN. 2	TRANSMIT ATTEN. 1	TRANSMIT ATTEN. 0
			ALTERNATE TRANSMIT DATA SOURCE	0=CLOCK DRIVEN 1=CLOCK TRISTATE		0=NO BOOST 1=18 dB BOOST	0000-1111, SETS TRANSMIT ATTENUATOR 16 dB RANGE DEFAULT=0100 -10 dB/M0			
SPECIAL REGISTER	SR	101	0	TX BAUD CLOCK	RX UNSCR. DATA	0	TXD SOURCE	SQ SELECT1	SQ SELECT0	0
				OUTPUTS TXBAUD CLOCK	OUTPUTS UNSCR. DATA		0=TXD PIN 1=TX DATA CR3-D7	00 10 ⁻⁵ BER 01 10 ⁻⁶ BER 10 10 ⁻⁴ BER 11 10 ⁻³ BER		
ID REGISTER	10	110	1	1	1	0	X	X	X	X

00XX=73K212L, 322L, 321L
01XX=73K221L, 302L
10XX=73K222L
1100=73K224L
1110=73K324L
1101=73K312L

0 = Only write zero to these locations

x = Undefined-mask in software

SSI 73K324L
CCITT V.22bis, V.22, V.21, V.23, Bell 212A
Single-Chip Modem

CONTROL REGISTER 0

	D7	D6	D5	D4	D3	D2	D1	D0
CR0 000	MODUL. OPTION	MODUL. TYPE 1	MODUL. TYPE 0	TRANSMIT MODE 2	TRANSMIT MODE 1	TRANSMIT MODE 0	TRANSMIT ENABLE	ANSWER/ ORIGINATE
BIT NO.	NAME		CONDITION	DESCRIPTION				
D0	Answer/ Originate		0	Selects Answer mode (transmit in high band, receive in low band) or in V.23 HDX mode, receive at 1200 bit/s and transmit at 75 bit/s.				
			1	Selects Originate mode (transmit in low band, receive in high band) or in V.23 HDX mode, receive at 75 bit/s and transmit at 1200 bit/s.				
			Note: This bit works with Tone Register bits D0 and D6 to program special tones detected in the Detect Register. See Detect and Tone Registers.					
D1	Transmit Enable		0	Disables transmit output at TXA.				
			1	Enables transmit output at TXA.				
			Note: Transmit Enable must be set to 1 to allow activation of Answer Tone, DTMF, or Carrier.					
D5, D4, D3, D2	Transmit Mode		D5 D4 D3 D2	Selects Power Down mode. All functions disabled except digital interface.				
			0 0 0 0					
			0 0 0 1	Internal Synchronous mode. In this mode TXCLK is an internally derived 600, 1200 or 2400 Hz signal. Serial input data appearing at TXD must be valid on the rising edge of TXCLK. Receive data is clocked out of RXD on the falling edge of RXCLK.				
			0 0 1 0	External Synchronous mode. Operation is identical to internal synchronous, but TXCLK is connected internally to EXCLK pin, and a 600, 1200 or 2400 Hz clock must be supplied externally.				
			0 0 1 1	Slave Synchronous mode. Same operation as other Synchronous modes. TXCLK is connected internally to the RXCLK pin in this mode.				
			0 1 0 0	Selects Asynchronous mode - 8 bits/character (1 start bit, 6 data bits, 1 stop bit).				
			0 1 0 1	Selects Asynchronous mode - 9 bits/character (1 start bit, 7 data bits, 1 stop bit).				
			0 1 1 0	Selects Asynchronous mode - 10 bits/character (1 start bit, 8 data bits, 1 stop bit).				
			0 1 1 1	Selects Asynchronous mode - 11 bits/character (1 start bit, 8 data bits, Parity and/or 1 or 2 stop bits).				
			1 X 0 0	Selects FSK operation.				

SSI 73K324L
CCITT V.22bis, V.22, V.21, V.23, Bell 212A
Single-Chip Modem

CONTROL REGISTER 0 (continued)

BIT NO.	NAME	CONDITION	DESCRIPTION	
D6,D5	Modulation Type	D6 D5		
		1 0		QAM
		0 0		DPSK
		0 1		FSK
D7	Modulation Option	0	QAM selects 2400 bit/s. DPSK selects 1200 bit/s. FSK selects V.23 mode.	
		1	DPSK selects 600 bit/s. FSK selects V.21 mode.	

CONTROL REGISTER 1

	D7	D6	D5	D4	D3	D2	D1	D0
CR1 001	TRANSMIT PATTERN 1	TRANSMIT PATTERN 0	ENABLE DETECT INT.	BYPASS SCRAMB/ ADD PH.EQ	CLK CONTROL	RESET	TEST MODE 1	TEST MODE 0
BIT NO.	NAME	CONDITION	DESCRIPTION					
D1, D0	Test Mode	D1 D0						
		0 0		Selects Normal Operating mode.				
		0 1		Analog Loopback mode. Loops the transmitted analog signal back to the receiver, and causes the receiver to use the same carrier frequency as the transmitter. To squelch the TXA pin, transmit enable bit must be low. Tone Register bit D2 must be zero.				
		1 0		Selects remote digital loopback. Received data is looped back to transmit data internally, and RXD is forced to a mark. Data on TXD is ignored.				
		1 1		Selects local digital loopback. Internally loops TXD back to RXD and continues to transmit data carrier at TXA pin.				
D2	Reset	0	Selects normal operation.					
		1	Resets modem to power down state. All control register bits (CR0, CR1, CR2, CR3 and Tone) are reset to zero except CR3 bit D2. The output of the clock pin will be set to the crystal frequency.					
D3	CLK Control (Clock Control)	0	Selects 11.0592 MHz crystal echo output at CLK pin.					
		1	Selects 16 X the data rate output at CLK pin in QAM and DPSK only.					

SSI 73K324L
CCITT V.22bis, V.22, V.21, V.23, Bell 212A
Single-Chip Modem

CONTROL REGISTER 1 (continued)

	D7	D6	D5	D4	D3	D2	D1	D0
CR1 001	TRANSMIT PATTERN 1	TRANSMIT PATTERN 0	ENABLE DETECT INT.	BYPASS SCRAMB/ ADD PH.EQ.	CLK CONTROL	RESET	TEST MODE 1	TEST MODE 0
BIT NO.	NAME	CONDITION	DESCRIPTION					
D4	Bypass Scrambler/ Add Ph. Eq.	0	Selects normal operation. DPSK and QAM data is passed through scrambler.					
		1	Selects Scrambler Bypass. DPSK and QAM data is routed around scrambler in the transmit path. In the V.23 mode, additional phase equalization is added to the main channel filters when D4 is set to 1.					
D5	Enable Detect Interrupt	0	Disables interrupt at $\overline{\text{INT}}$ pin. All interrupts are normally disabled in Power Down mode.					
		1	Enables $\overline{\text{INT}}$ output. An interrupt will be generated with a change in status of DR bits D1-D4 and D6. The answer tone and call progress detect interrupts are masked when the TX enable bit is set. Carrier detect is masked when TX DTMF is activated. All interrupts will be disabled if the device is in Power Down mode.					
D7, D6	Transmit Pattern	D7 D6						
		0 0	Selects normal data transmission as controlled by the state of the TXD pin.					
		0 1	Selects an alternating mark/space transmit pattern for modem testing and handshaking. Also used for S1 pattern generation. See CR2 bit D4.					
		1 0	Selects a constant mark transmit pattern.					
		1 1	Selects a constant space transmit pattern.					

SSI 73K324L
CCITT V.22bis, V.22, V.21, V.23, Bell 212A
Single-Chip Modem

DETECT REGISTER

	D7	D6	D5	D4	D3	D2	D1	D0
DR 010	RECEIVE LEVEL INDICATOR	S1 PATTERN DETECT	RECEIVE DATA	UNSCR. MARK DETECT	CARRIER DETECT	SPECIAL TONE DETECT	CALL PROG. DETECT	SIGNAL QUALITY INDICATOR
BIT NO.	NAME	CONDITION			DESCRIPTION			
D0	Signal Quality Indicator	0			Indicates normal received signal.			
		1			Indicates low received signal quality (above average error rate). Interacts with Special Register SQ bits D2, D1.			
D1	Call Progress Detect	0			No call progress tone detected.			
		1			Indicates presence of call progress tones. The call progress detection circuitry is activated by energy in the normal 350 to 620 Hz call progress band.			
D2	Special Tone Detect	0			Condition not detected			
		1			Condition detected			
		CR0 D0	TR D0	CR2 D5				
		1	0	1	2225 Hz \pm 10 Hz answer tone detected in V.22bis, V.22, V.21 modes.			
		1	1	1	2100 Hz \pm 21 Hz answer tone detected in V.22bis, V.22, V.21 modes.			
		0	X	0	900 Hz SCT tone detected in V.23 mode.			
D3	Carrier Detect	0			No carrier detected in the receive channel.			
		1			Indicated carrier has been detected in the received channel. Should be time qualified by software.			
D4	Unscr. Mark Detect	0			No unscrambled mark being received.			
		1			Indicates detection of unscrambled marks in the received data. Should be time qualified by software.			
D5	Receive Data				Continuously outputs the received data stream. This data is the same as that output on the RXD pin, but it is not disabled when RXD is tri-stated.			
D6	S1 Pattern Detect	0			No S1 pattern being received.			
		1			S1 pattern detected. Should be time qualified by software. S1 is an unscrambled double dibit (11001100...) sent in DPSK 1200 bit/s mode. Generated pattern must be properly aligned to transmitter baud clock to be detected.			
D7	Receive Level Indicator	0			Received signal level below threshold, (\approx -25 dBm0); can use receive gain boost (+18 dB)			
		1			Received signal above threshold.			

SSI 73K324L
CCITT V.22bis, V.22, V.21, V.23, Bell 212A
Single-Chip Modem

TONE REGISTER

	D7	D6	D5	D4	D3	D2	D1	D0	
TR 011	RXD OUTPUT CONTR.	TRANSMIT GUARD/ CALLING/SCT TONE	TRANSMIT ANSWER TONE	TRANSMIT DTMF	DTMF 3	DTMF 2/ WIRE FDX	DTMF 1/ OVER-SPEED	DTMF 0/ G.T./ANSW./ CALLING/SCT TONE/SEL	
BIT NO.	NAME	CONDITION			DESCRIPTION				
D0, D4, D5, D6	DTMF 0/ Guard Tone/ Answer Tone/ Calling/SCT Tone/ Transmit Select	D6 D5 D4 D0			D0 interacts with bits D6, D5, D4, and CR0 as shown.				
		X	X	1	X	Transmit DTMF tones (overrides all other functions).			
		1	0	0	0	Select 1800 Hz guard tone if in V.22bis or V.22 and Answer mode in CR0.			
		1	0	0	1	Select 550 Hz guard tone if in V.22bis or V.22 and Answer mode in CR0.			
		Note: Bit D0 also selects the answer tone detected in Originate mode, see Detect Register Special Tone Detect (bit D2) for details.							
		1	0	0	0	1300 Hz calling tone will be transmitted if V.21, V.22, V.22bis or V.23 Originate mode is selected in CR0.			
		X	1	0	0	Transmit 2225 Hz Answer Tone. Must be in DPSK Answer mode.			
		X	1	0	1	Transmit 2100 Hz Answer Tone. Must be in DPSK Answer mode.			
D1	DTMF 1/ Overspeed	D4 D1			D1 interacts with D4 as shown.				
		0	0	Asynchronous QAM/DPSK +1% -2.5%. (Normal).					
		0	1	Asynchronous QAM/DPSK, 2400, 1200 or 600 bit/s +2.3% -2.5%. (Extended overspeed).					
D2	DTMF 2/ 4 WIRE FDX	D4 D2							
		0	0	Selects 2-wire full-duplex or half-duplex.					
		0	1	D2 selects 4 wire full duplex in the Modulation mode selected. The receive path corresponds to the ANS/ ORIG bit CR0 D0 in terms of high or low band selection. The transmitter is in the same band as the receiver, but does not have magnitude filtering or equalization on its signal as in the receive path.					

Note: DTMF0 - DTMF2 should be set to an appropriate state after DTMF dialing to avoid unintended operation.

SSI 73K324L
CCITT V.22bis, V.22, V.21, V.23, Bell 212A
Single-Chip Modem

TONE REGISTER (continued)

	D7	D6	D5	D4	D3	D2	D1	D0																																																																																																																											
TR 011	RXD OUTPUT CONTR.	TRANSMIT GUARD/ CALLING/SCT TONE	TRANSMIT ANSWER TONE	TRANSMIT DTMF	DTMF 3	DTMF 2/ WIRE FDX	DTMF 1/ OVER-SPEED	DTMF 0/ GUARD/ CALLING/SCT TONE SEL																																																																																																																											
BIT NO.	NAME	CONDITION	DESCRIPTION																																																																																																																																
D3, D2, D1, D0	DTMF 3, 2, 1, 0	D4 = 1	Programs 1 of 16 DTMF tone pairs that will be transmitted when TX DTMF and TX enable bit (CR0, bit D1) is set. Tone encoding is shown below: <table border="1" style="margin-left: auto; margin-right: auto;"> <thead> <tr> <th rowspan="2"></th> <th colspan="2">DTMF CODE</th> <th colspan="2">TONES</th> </tr> <tr> <th>D3</th> <th>D2</th> <th>D1</th> <th>D0</th> <th>LOW</th> <th>HIGH</th> </tr> </thead> <tbody> <tr><td>1</td><td>0</td><td>0</td><td>0</td><td>1</td><td>697</td><td>1209</td></tr> <tr><td>2</td><td>0</td><td>0</td><td>1</td><td>0</td><td>697</td><td>1336</td></tr> <tr><td>3</td><td>0</td><td>0</td><td>1</td><td>1</td><td>697</td><td>1477</td></tr> <tr><td>4</td><td>0</td><td>1</td><td>0</td><td>0</td><td>770</td><td>1209</td></tr> <tr><td>5</td><td>0</td><td>1</td><td>0</td><td>1</td><td>770</td><td>1336</td></tr> <tr><td>6</td><td>0</td><td>1</td><td>1</td><td>0</td><td>770</td><td>1477</td></tr> <tr><td>7</td><td>0</td><td>1</td><td>1</td><td>1</td><td>852</td><td>1209</td></tr> <tr><td>8</td><td>1</td><td>0</td><td>0</td><td>0</td><td>852</td><td>1336</td></tr> <tr><td>9</td><td>1</td><td>0</td><td>0</td><td>1</td><td>852</td><td>1477</td></tr> <tr><td>0</td><td>1</td><td>0</td><td>1</td><td>0</td><td>941</td><td>1336</td></tr> <tr><td>*</td><td>1</td><td>0</td><td>1</td><td>1</td><td>941</td><td>1209</td></tr> <tr><td>#</td><td>1</td><td>1</td><td>0</td><td>0</td><td>941</td><td>1477</td></tr> <tr><td>A</td><td>1</td><td>1</td><td>0</td><td>1</td><td>697</td><td>1633</td></tr> <tr><td>B</td><td>1</td><td>1</td><td>1</td><td>0</td><td>770</td><td>1633</td></tr> <tr><td>C</td><td>1</td><td>1</td><td>1</td><td>1</td><td>852</td><td>1633</td></tr> <tr><td>D</td><td>0</td><td>0</td><td>0</td><td>0</td><td>941</td><td>1633</td></tr> </tbody> </table>							DTMF CODE		TONES		D3	D2	D1	D0	LOW	HIGH	1	0	0	0	1	697	1209	2	0	0	1	0	697	1336	3	0	0	1	1	697	1477	4	0	1	0	0	770	1209	5	0	1	0	1	770	1336	6	0	1	1	0	770	1477	7	0	1	1	1	852	1209	8	1	0	0	0	852	1336	9	1	0	0	1	852	1477	0	1	0	1	0	941	1336	*	1	0	1	1	941	1209	#	1	1	0	0	941	1477	A	1	1	0	1	697	1633	B	1	1	1	0	770	1633	C	1	1	1	1	852	1633	D	0	0	0	0	941	1633
	DTMF CODE		TONES																																																																																																																																
	D3	D2	D1	D0	LOW	HIGH																																																																																																																													
1	0	0	0	1	697	1209																																																																																																																													
2	0	0	1	0	697	1336																																																																																																																													
3	0	0	1	1	697	1477																																																																																																																													
4	0	1	0	0	770	1209																																																																																																																													
5	0	1	0	1	770	1336																																																																																																																													
6	0	1	1	0	770	1477																																																																																																																													
7	0	1	1	1	852	1209																																																																																																																													
8	1	0	0	0	852	1336																																																																																																																													
9	1	0	0	1	852	1477																																																																																																																													
0	1	0	1	0	941	1336																																																																																																																													
*	1	0	1	1	941	1209																																																																																																																													
#	1	1	0	0	941	1477																																																																																																																													
A	1	1	0	1	697	1633																																																																																																																													
B	1	1	1	0	770	1633																																																																																																																													
C	1	1	1	1	852	1633																																																																																																																													
D	0	0	0	0	941	1633																																																																																																																													
D7	RXD Output Control	0	Enables RXD pin. Receive data will be output on RXD.																																																																																																																																
		1	Disables RXD pin. The RXD pin reverts to a high impedance with internal weak pull-up resistor.																																																																																																																																

SSI 73K324L
CCITT V.22bis, V.22, V.21, V.23, Bell 212A
Single-Chip Modem

CONTROL REGISTER 2

	D7	D6	D5	D4	D3	D2	D1	D0
CR2 100	0	SPEC REG ACCESS	CALL INIT	TRANSMIT S1	16 WAY	RESET DSP	TRAIN INHIBIT	EQUALIZER ENABLE
BIT NO.	NAME		CONDITION	DESCRIPTION				
D0	Equalizer Enable		0	The adaptive equalizer is in its initialized state.				
			1	The adaptive equalizer is enabled. This bit is used in handshakes to control when the equalizer should calculate its coefficients.				
D1	Train Inhibit		0	The adaptive equalizer is active.				
			1	The adaptive equalizer coefficients are frozen.				
D2	RESET DSP		0	The DSP is inactive and all variables are initialized.				
			1	The DSP is running based on the mode set by other control bits				
D3	16 Way		0	The receiver and transmitter are using the same decision plane (based on the Modulator Control Mode).				
			1	The receiver, independent of the transmitter, is forced into a 16 point decision plane. Used for QAM handshaking.				
D4	Transmit S1		0	The transmitter when placed in alternating Mark/Space mode transmits 0101 scrambled or not dependent on the bypass scrambler bit and Modulation mode.				
			1	When this bit is 1 and only when the transmitter is placed in alternating Mark/Space mode by CR1 bits D7, D6, an unscrambled repetitive double dibit pattern of 00 and 11 at 1200 bit/s (S1) is sent.				
D5	Call Init		0	The DSP is setup to do demodulation and pattern detection based on the Various mode bits. Both answer tones are detected in Demod Mode concurrently; TR D0 is ignored.				
			1	The DSP decodes call progress, calling tones, unscrambled mark, and 2100 Hz and 2225 Hz answer tones.				
D6	Special Register Access		0	Normal CR3 access.				
			1	Setting this bit and addressing CR3 allows access to the SPECIAL REGISTER. See the SPECIAL REGISTER for details.				
D7	N/A		0	Must be 0 for normal operation.				

SSI 73K324L
CCITT V.22bis, V.22, V.21, V.23, Bell 212A
Single-Chip Modem

CONTROL REGISTER 3

	D7	D6	D5	D4	D3	D2	D1	D0
CR3 101	TXDALT	TRISTATE TX/RXCLK	0	RECEIVE ENABLE BOOST	TRANSMIT ATTEN. 3	TRANSMIT ATTEN. 2	TRANSMIT ATTEN. 1	TRANSMIT ATTEN. 0
BIT NO.	NAME		CONDITION		DESCRIPTION			
D3, D2, D1,D0	Transmit Attenuator		D3 D2 D1 D0		Sets the attenuation level of the transmitted signal in 1 dB steps. The default (D3-D0=0100) is for a transmit level of -10 dBm0. The total range is 16 dB.			
			0 0 0 0 - 1 1 1 1					
D4	Receive Gain Boost (18 dB)		0		18 dB receive front end boost is not used.			
			1		Boost is in the path. This boost does not change reference levels. It is used to extend dynamic range by compensating for internally generated noise when receiving weak signals. The receive level detect signal and knowledge of the hybrid and transmit attenuator setting will determine when boost should be enabled.			
D5	Not Used		0		Not used. Only write zeros this location.			
D6	Tristate TXCLK/RXCLK		0		TXCLK, RXCLK outputs driven			
			1		TXCLK, RXCLK outputs in Tristate mode			
D7	TXDALT		Spec. Reg. bit D3=1		Alternate TX data source. See Special Register.			

ID REGISTER

SPECIAL REGISTER

	D7	D6	D5	D4	D3	D2	D1	D0
SR 101	0	TXBAUD CLOCK	RXUN- DSCR DATA	0	TXD SOURCE	SIGNAL QUALITY LEVEL SELECT1	SIGNAL QUALITY LEVEL SELECT0	0
BIT NO.	NAME		DESCRIPTION					
D7, D4, D0			NOT USED AT THIS TIME. Only write ZEROs to these bits.					
D6	TXBAUD CLK		TXBAUD clock is the transmit baud-synchronous clock that can be used to synchronize the input of arbitrary quad/di-bit patterns. The rising edge of TXBAUD signals the latching of a baud-worth of data internally. Synchronous data to be entered via the TXDALT bit, CR3 bit D7, should have data transitions that start 1/2 bit period delayed from the TXBAUD clock edges.					
D5	RXUNDSCR DATA		This bit outputs the data received before going to the descrambler. This is useful for sending special unscrambled patterns that can be used for signaling.					

SSI 73K324L

CCITT V.22bis, V.22, V.21, V.23, Bell 212A

Single-Chip Modem

SPECIAL REGISTER (continued)

BIT NO.	NAME	DESCRIPTION		
D3	TXD SOURCE	This bit selects the transmit data source; either the TXD pin if ZERO or the TXDALT if this bit is a ONE. The TRANSMIT PATTERN bits D7 and D6 in CR1 override either of these sources.		
D2, D1	SIGNAL QUALITY LEVEL SELECT	The signal quality indicator is a logical zero when the signal received is acceptable for low error rate reception. It is determined by the value of the Mean Squared Error (MSE) calculated in the decisioning process when compared to a given threshold. This threshold can be set to four levels of error rate. The SQI bit will be low for good or average connections. As the error rate crosses the threshold setting, the SQI bit will toggle at a 1.66 ms rate. Toggling will continue until the error rate indicates that the data pump has lost convergence and a retrain is required. At that point the SQI bit will be a ONE constantly. The SQI bit and threshold selection are valid for QAM and DPSK only.		
		TYPICAL THRESHOLD VALUE	UNITS	
		0 0	10^{-5}	BER (default)
		0 1	10^{-6}	BER
		1 0	10^{-4}	BER
1 1	10^{-3}	BER		

NOTE: This register is "mapped" and is accessed by setting CR2 bit D6 to a ONE and addressing CR3. This register provides functions to the 73K324L user that are not necessary in normal communications. Bits D7-D4 are read only, while D3-D0 are read/write. To return to normal CR3 access, CR2 bit D6 must be returned to a ZERO.

ID	D7	D6	D5	D4	D3	D2	D1	D0
110	ID 3	ID 2	ID 1	ID 0	X	X	X	X

BIT NO.	NAME	CONDITION	DESCRIPTION
D7, D6, D5, D4	Device Identification Signature	D7 D6 D5 D4	Indicates Device:
		0 0 X X	SSI 73K212L or 73K322L or 73K321L
		0 1 X X	SSI 73K221L or 73K302L
		1 0 X X	SSI 73K222L
		1 1 0 0	SSI 73K224L
		1 1 1 0	SSI 73K324L
		1 1 0 1	SSI 73K312L
D3-D0	Undefined	NA	Mask in software

SSI 73K324L

CCITT V.22bis, V.22, V.21, V.23, Bell 212A

Single-Chip Modem

ELECTRICAL SPECIFICATIONS

ABSOLUTE MAXIMUM RATINGS

PARAMETER	RATING
VDD Supply Voltage	7V
Storage Temperature	-65 to 150°C
Soldering Temperature (10 sec.)	260°C
Applied Voltage	-0.3 to VDD+0.3V
Note: All inputs and outputs are protected from static charge using built-in, industry standard protection devices and all outputs are short-circuit protected.	

RECOMMENDED OPERATING CONDITIONS

PARAMETER	CONDITION	MIN	NOM	MAX	UNIT
VDD Supply voltage		4.5	5	5.5	V
External Components (Refer to Application section for placement.)					
VREF Bypass capacitor	(VREF to GND)	0.22			μF
Bias setting resistor	(Placed between VDD and ISET pins)	1.8	2	2.2	MΩ
ISET Bypass capacitor	(ISET pin to GND)	0.22			μF
VDD Bypass capacitor 1	(VDD to GND)	0.22			μF
VDD Bypass capacitor 2	(VDD to GND)	22			μF
XTL1 Load Capacitance	Depends on crystal requirements		18	39	pF
XTL2 Load Capacitance	Depends on crystal requirements		18	27	pF
Clock Variation	(11.0592 MHz) Crystal or external clock	-0.01		+0.01	%
TA, Operating Free-Air Temperature		-40		85	°C

SSI 73K324L
CCITT V.22bis, V.22, V.21, V.23, Bell 212A
Single-Chip Modem

DC ELECTRICAL CHARACTERISTICS

(TA = -40°C to 85°C, VDD = recommended range unless otherwise noted)

PARAMETER	CONDITION	MIN	NOM	MAX	UNIT
IDD, Supply Current	CLK = 11.0592 MHz ISET Resistor = 2 MΩ				
IDD1, Active	Operating with crystal oscillator		18	25	mA
IDD2, Idle	< 5 pF capacitive load on CLK pin			5	mA
Digital Inputs					
VIL, Input Low Voltage				0.8	V
VIH, Input High Voltage					
All Inputs except Reset XTL1, XTL2		2.0		VDD	V
Reset, XTL1, XTL2		3.0		VDD	V
IIH, Input High Current	VI = VDD			100	μA
IIL, Input Low Current	VI = 0V	-200			μA
Reset Pull-down Current	Reset = VDD	-2	-30	-70	μA
Digital Outputs					
VOH, Output High Voltage	IO = IOH Min IOUT = -0.4 mA	2.4		VDD	V
VOL, Output Low Voltage	IO = IOUT = 1.6 mA			0.4	V
RXD Tri-State Pull-up Curr.	RXD = GND	-2		-50	μA
Capacitance					
Maximum Capacitive Load					
CLK				25	pF
Input Capacitance	All Digital Inputs			10	pF

SSI 73K324L

CCITT V.22bis, V.22, V.21, V.23, Bell 212A

Single-Chip Modem

DYNAMIC CHARACTERISTICS AND TIMING

(TA = -40°C to +85°C, VDD = recommended range unless otherwise noted)

PARAMETER	CONDITION	MIN	NOM	MAX	UNIT
QAM/DPSK Modulator					
Carrier Suppression	Measured at TXA	35			dB
Output Amplitude	TX scrambled marks ATT= 0100 (default)	-11.5	-10.0	-9	dBm0
FSK Modulator/Demodulator					
Output Freq. Error	CLK = 11.0592 MHz	-31		+0.20	%
Transmit Level	ATT = 0100 (Default) Transmit Dotting Pattern	-11.5	-10.0	-9	dBm0
TXA Output Distortion	All products through BPF			-45	dB
Output Bias Distortion at RXD	Dotting Pattern measured at RXD Receive Level -20 dBm, SNR 20 dB	-10		+10	%
Output Jitter at RXD	Integrated for 5 seconds	-15		+15	%
Sum of Bias Distortion and Output Jitter at RXD	Integrated for 5 seconds	-15		+15	%
2100 Hz Answer Tone Generator					
Output Amplitude	ATT = 0100 (Default Level) Not in V.21 or V.23 Mode	-11.5	-10	-9	dBm0
Output Distortion	Distortion products in receive band			-40	dB
DTMF Generator Not in V.21 or V.23 mode					
Freq. Accuracy		-0.03		+0.25	%
Output Amplitude	Low Band, ATT = 0100	-10		-8	dBm0
Output Amplitude	High Band, ATT = 0100	-8		-6	dBm0
Twist	High-Band to Low-Band	1.0	2.0	3.0	dB
Receiver Dynamic Range	Refer to Performance Curves	-43		-3.0	dBm0
Call Progress Detector In Call Init mode					
Detect Level	460 Hz input signal	-34		0	dBm0
Reject Level				-40	dBm0
Delay Time	-70 dBm0 to -30 dBm0 STEP			25	ms
Hold Time	-30 dBm0 to -70 dBm0 STEP			25	ms
Hysteresis	@ 460 Hz input signal	2			dB

NOTE: Parameters expressed in dBm0 refer to the following definition:

0 dB loss in the Transmit path to the line

2 dB gain in the Receive path from the line

Refer to the Basic Box Modem diagram in the Applications section for the DAA design.

SSI 73K324L
CCITT V.22bis, V.22, V.21, V.23, Bell 212A
Single-Chip Modem

DYNAMIC CHARACTERISTICS AND TIMING (continued)

PARAMETERS		CONDITIONS	MIN	NOM	MAX	UNITS
Carrier Detect Receive Gain Boost "On" for Lower Input Level Measurements						
Threshold		QAM/DPSK or FSK receive data	-48		-43	dBm0
Hysteresis		All Modes	2			dB
Delay Time	FSK	70 dBm0 to -6 dBm0	25		37	ms
		70 dBm0 to -40 dBm0	25		37	ms
	DPSK	-70 dBm0 to -6 dBm0	7		17	ms
		-70 dBm0 to -40 dBm0	7		17	ms
	QAM	-70 dBm0 to -6 dBm0	25		37	ms
		-70 dBm0 to -40 dBm0	25		37	ms
Hold Time	FSK	-6 dBm0 to -70 dBm0	25		37	ms
		-40 dBm0 to -70 dBm0	15		30	ms
	DPSK	-6 dBm0 to -70 dBm0	20		29	ms
		-40 dBm0 to -70 dBm0	14		21	ms
	QAM	-6 dBm0 to -70 dBm0	25		32	ms
		-40 dBm0 to -70 dBm0	8		28	ms
Special Tone Detectors						
Detect Level		See definitions for D0 of Tone Register	-48		-43	dBm0
Delay and Hold Time						
2225 or 2100 Hz answer tone		Call INIT mode 2225 ± 10 Hz 2100 ± 21 Hz	6		50	ms
900 Hz SCT Receive V.23 main channel		Tone Accuracy ±9 Hz	10		45	ms
Hysteresis			2			dB
Pattern Detectors		DPSK Mode				
S1 Pattern						
Delay Time		For signals from -6 to -40 dBm0, Demod Mode	10		55	ms
Hold Time			10		45	ms
Unscrambled Mark						
Delay Time		For signals from -6 to -40 Demod or call Init Mode	10		45	ms
Hold Time			10		45	ms
Receive Level Indicator						
Detect On			-22		-28	dBm0
Valid after Carrier Detect		DPSK Mode	1	4	7	ms

SSI 73K324L
CCITT V.22bis, V.22, V.21, V.23, Bell 212A
Single-Chip Modem

DYNAMIC CHARACTERISTICS AND TIMING (continued)

PARAMETER	CONDITION	MIN	NOM	MAX	UNIT
Output Smoothing Filter					
Output Impedance	TXA pin		200	300	Ω
Output Load	TXA pin; FSK Single	10			k Ω
	Tone out for THD = -50 dB in 0.3 to 3.4 kHz range			50	pF
Maximum Transmitted Energy	4 kHz, Guard Tones off			-35	dBm0
	10 kHz, Guard Tones off			-55	dBm0
	12 kHz, Guard Tones off			-65	dBm0
Anti Alias Low Pass Filter					
Maximum allowed Out-of-Band Signal Energy (Defines Hybrid Trans-Hybrid loss requirements)	Scrambled data at 2400 bit/s in opposite band		-14		dBm
	Sinusoids out of band		-9		dBm
Transmit Attenuator					
Range of Transmit Level	1111-0000 Default ATT = 0100 (-10 dBm0)	-21		-6	dBm0
Step Accuracy		-0.15		+0.15	dB
Clock Noise	TXA pin; 153.6 kHz		1.5		mV rms
Carrier Offset					
Capture Range	Originate or Answer		± 5		Hz
Recovered Clock					
Capture Range	% of data rate originate or answer	-0.02		+0.02	%
Guard Tone Generator					
Tone Accuracy	550 Hz		+1.2		%
Tone Level (Below QAM/DPSK Output)	1800 Hz		-0.8		%
	550 Hz	-4.5	-3.0	-1.5	dB
	1800 Hz	-7.5	-6.1	-4.5	dB
Harmonic Distortion (700 to 2900 Hz)	550 or 1800 Hz			-50	dB

SSI 73K324L
CCITT V.22bis, V.22, V.21, V.23, Bell 212A
Single-Chip Modem

DYNAMIC CHARACTERISTICS AND TIMING (continued)

PARAMETER	CONDITION	MIN	NOM	MAX	UNIT
Timing (Refer to Timing Diagrams)					
Parallel Mode:					
TAL	$\overline{CS}/\text{Addr. setup before ALE Low}$	30			ns
TLA	$\overline{CS}/\text{Addr. hold after ALE Low}$	6			ns
TLC	ALE Low to $\overline{RD}/\overline{WR}$ Low	40			ns
TCL	$\overline{RD}/\overline{WR}$ Control to ALE High	10			ns
TRD	Data out from \overline{RD} Low			90	ns
TLL	ALE width	25			ns
TRDF	Data float after \overline{RD} High			40	ns
TRW	\overline{RD} width	70			ns
TWW	\overline{WR} width	70			ns
TDW	Data setup before \overline{WR} High	70			ns
TWD	Data hold after \overline{WR} High	20			ns
Serial Mode:					
TRCK	Clock high after \overline{RD}	250		T1	ns
TAR	Address setup before \overline{RD} low	0			ns
TRA	Address hold after \overline{RD} low	350			ns
TRD	\overline{RD} to data valid			110	ns
TRDF	Data float after \overline{RD} high			50	ns
TCKDR	Read data out after falling edge of EXCLK			300	ns
TWW	\overline{WR} width	350			ns
TAW	Address setup before \overline{WR}	50			ns
TWA	Address hold after rising edge of \overline{WR}	50			ns
TCKDW	Write data hold after falling edge of EXCLK	200			ns
TCKW	\overline{WR} high after falling edge of EXCLK	330		T1 & T2	ns
TDCK	Data setup before falling edge of EXCLK	50			ns
T1, T2	Minimum period	500			ns
Note: T1 and T2 are the low/high periods, respectively, of EXCLK in Serial mode.					

NOTE: Asserting ALE, \overline{CS} , and \overline{RD} or \overline{WR} concurrently can cause unintentional register accesses. When using non-8031 compatible processors, care must be taken to prevent this from occurring when designing the interface logic.

SSI 73K324L

CCITT V.22bis, V.22, V.21, V.23, Bell 212A

Single-Chip Modem

TIMING DIAGRAMS

BUS TIMING DIAGRAM (PARALLEL VERSION)

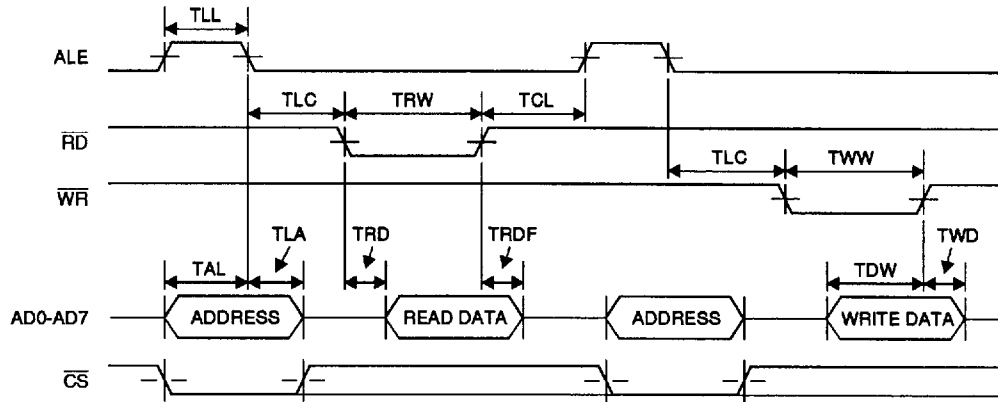

READ TIMING DIAGRAM (SERIAL VERSION)

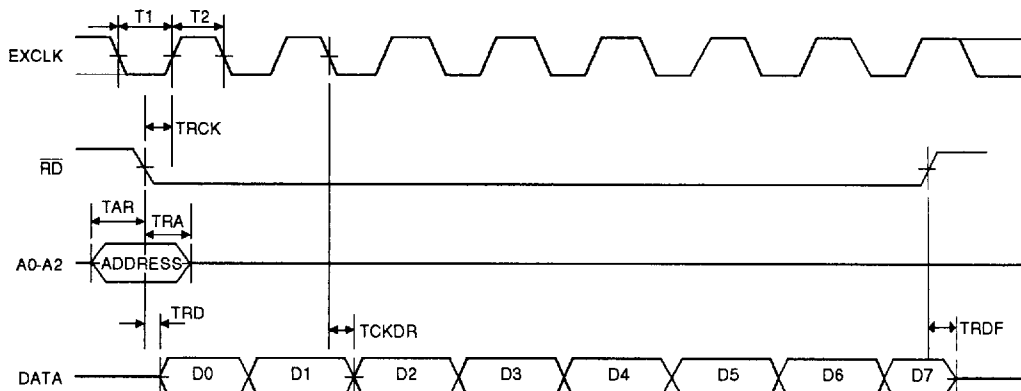

WRITE TIMING DIAGRAM (SERIAL VERSION)

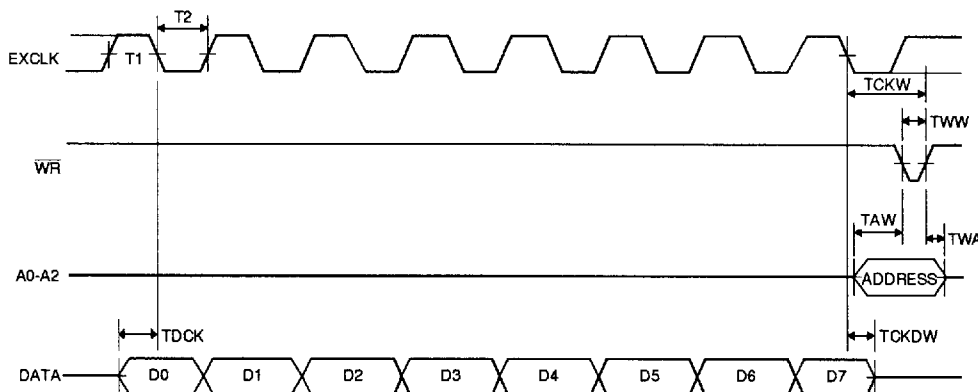

SSI 73K324L

CCITT V.22bis, V.22, V.21, V.23, Bell 212A

Single-Chip Modem

APPLICATIONS INFORMATION

GENERAL CONSIDERATIONS

Figures 1 and 2 show basic circuit diagrams for K-Series modem integrated circuits. K-Series products are designed to be used in conjunction with a control processor, a UART or RS-232 serial data interface, and a DAA phone line interface to function as a typical intelligent modem. The K-Series ICs interface directly with Intel 8048 and 80C51 microprocessors for control and status monitoring purposes. Two typical DAA arrangements are shown: one for a split ± 5 or ± 12 volt design and one for a single 5 volt design. These diagrams are for reference only and do not represent production-ready modem designs.

K-Series devices are available with two control interface versions: one for a parallel multiplexed address/data interface, and one for a serial interface. The parallel version is intended for use with 8039/48 or 8031/51 microcontrollers from Intel or many other manufacturers. The serial interface 22-pin version can be used with other microcontrollers or in applications where only a limited number of port lines are available or the application does not lend itself to a multiplexed address/data interface. The parallel versions may also be used in the Serial mode, as explained in the data sheet pin description.

In most applications the controller will monitor the serial data for commands from the DTE and the received data for break signals from the far end modem. In this way, commands to the modem are sent over the same line as the transmitted data. In other applications the RS-232 interface handshake lines are used for modem control.

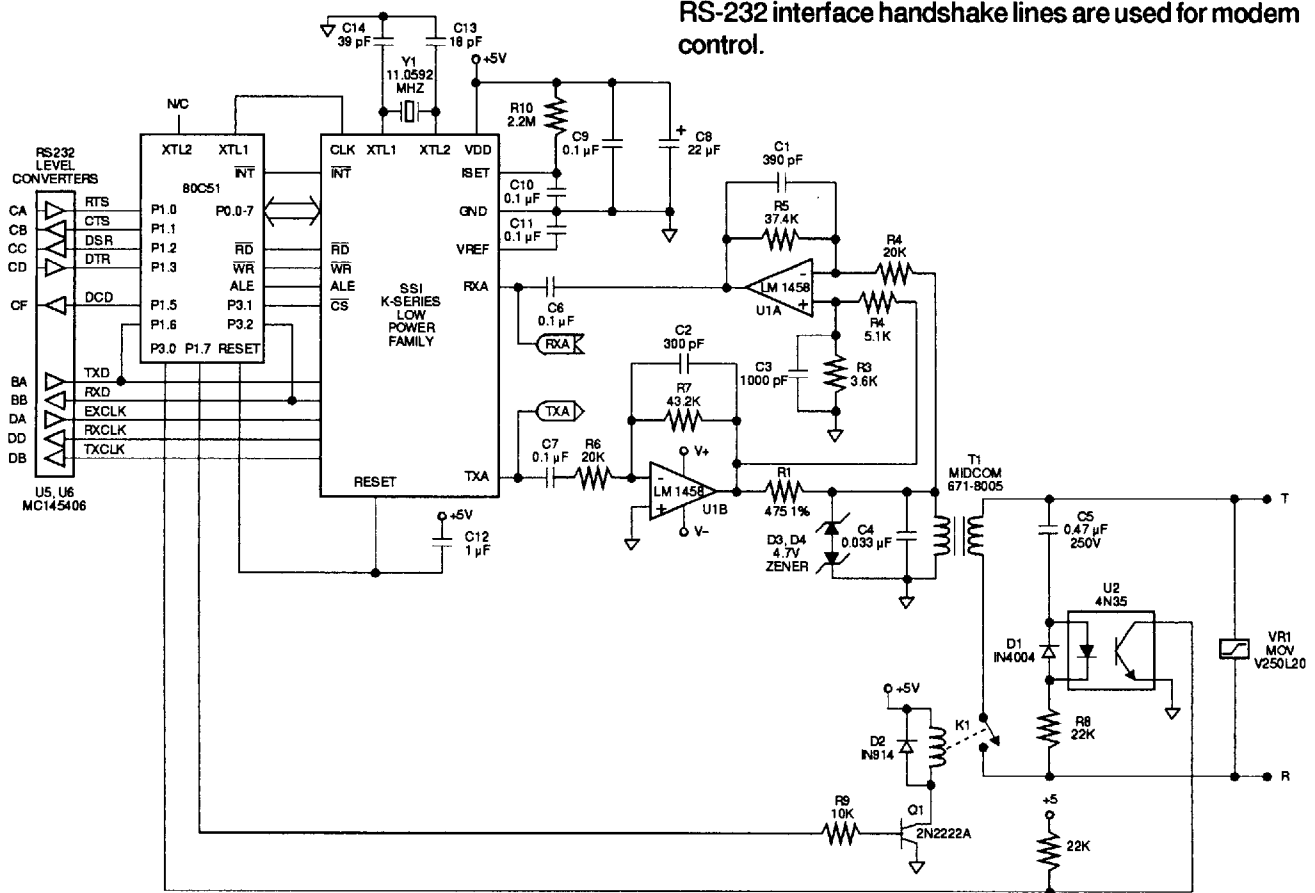

FIGURE 1: Basic Box Modem with Dual-Supply Hybrid

SSI 73K324L

CCITT V.22bis, V.22, V.21, V.23, Bell 212A

Single-Chip Modem

DIRECT ACCESS ARRANGEMENT (DAA)

The telephone line interfaces show two examples of how the "hybrid" may be implemented. The split supply design (Figure 1) is a typical two op-amp hybrid. The receive op-amp serves two purposes. It supplies gain to amplify the receive signal to the proper level for the modem's detectors and demodulator, and it removes the transmitted signal from the receive signal present at the transformer. This is done by supplying a portion of the transmitted signal to the non-inverting input of the receive op-amp at the same amplitude as the signal appearing at the transformer, making the transmit signal Common mode.

The single-supply hybrid is more complex than the dual-supply version described above, but its use eliminates the need for a second power supply. This circuit (Figure 2) uses a bridged drive to allow undistorted signals to be sent with a single 5 volt supply. Because DTMF tones utilize a higher amplitude than data, these

signals will clip if a single-ended drive approach is used. The bridged driver uses an extra op-amp (U1A) to invert the signal coming from the gain setting op-amp (U1B) before sending it to the other leg of the transformer. Each op-amp then supplies half the drive signal to the transformer. The receive amplifier (U1C) picks off its signal at the junction of the impedance matching resistor and the transformer. Because the bottom leg of the transformer is being driven in one direction by U1A and the resistor is driven in the opposite direction at the same time by U1B, the junction of the transformer and resistor remains relatively constant and the receive signal is unaffected.

DESIGN CONSIDERATIONS

Silicon Systems' 1-chip modem products include all basic modem functions. This makes these devices adaptable for use in a variety of applications, and as easy to control as conventional digital bus peripherals.

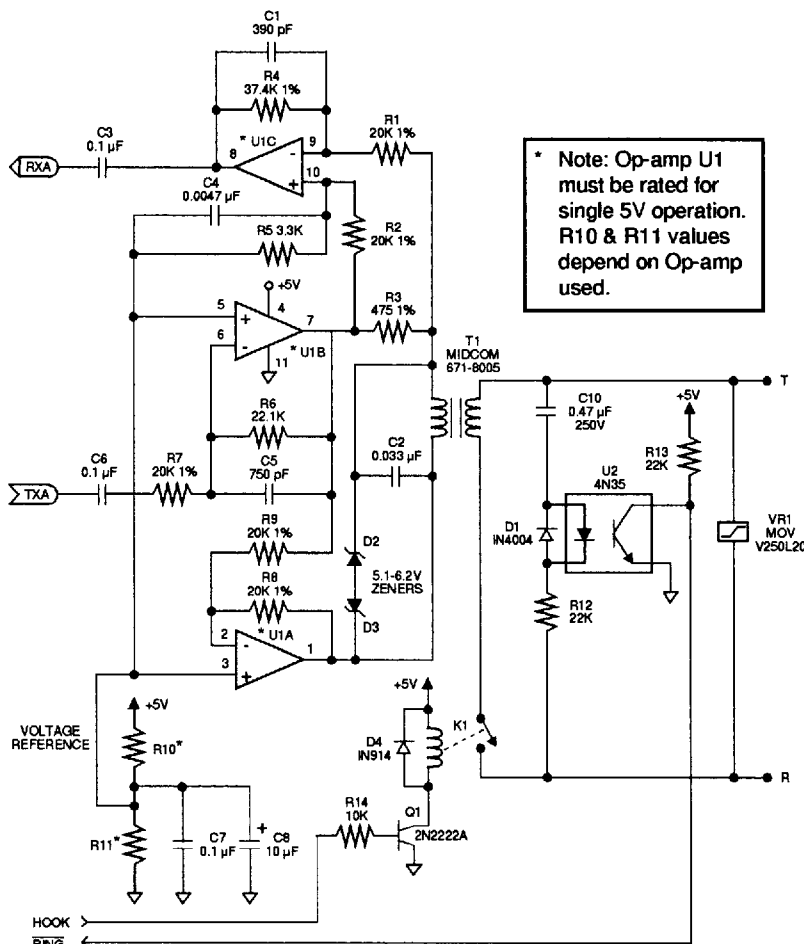

FIGURE 2: Single 5V Hybrid Version

SSI 73K324L CCITT V.22bis, V.22, V.21, V.23, Bell 212A Single-Chip Modem

Unlike digital logic circuitry, modem designs must properly contend with precise frequency tolerances and very low level analog signals, to ensure acceptable performance. Using good analog circuit design practices will generally result in a sound design. Following are additional recommendations which should be taken into consideration when starting new designs.

CRYSTAL OSCILLATOR

The K-Series crystal oscillator requires a Parallel mode (antiresonant) crystal which operates at 11.0592 MHz. It is important that this frequency be maintained to within $\pm 0.01\%$ accuracy.

In order for a Parallel mode crystal to operate correctly and to specification, it must have a load capacitor connected to the junction of each of the crystal and internal inverter connections, terminated to ground. The values of these capacitors depend primarily on the crystal's characteristics, and to a lesser degree on the internal inverter circuit. The values used affect the accuracy and start up characteristics of the oscillator.

LAYOUT CONSIDERATIONS

Good analog/digital design rules must be used to control system noise in order to obtain highest performance in modem designs. The more digital circuitry present on the PC board, the more this attention to noise control is needed. The modem should be treated as a high impedance analog device. A 22 μF electrolytic capacitor in parallel with a 0.22 μF ceramic capacitor between VDD and GND is recommended. Liberal use of ground planes and larger traces on power and ground are also highly favored. High speed digital circuits tend to generate a significant amount of EMI (Electro-Magnetic Interference) which must be minimized in order to meet regulatory agency limitations. To accomplish this, high speed digital devices should be locally bypassed, and the telephone line interface and K-Series device should be located close to each other near the area of the board where the phone line connection is accessed. To avoid problems, power supply and ground traces should be routed separately to the analog and digital functions on the board, and digital signals should not be routed near low level or high impedance analog traces. The analog and digital grounds should only connect at one point near the K-Series device ground pin to avoid ground loops. The K-Series modem IC's should have both high frequency and low frequency bypassing as close to the package as possible. The ISET resistor and bypass capacitor need to be as close to device as possible.

MODEM PERFORMANCE CHARACTERISTICS

The curves presented here define modem IC performance under a variety of line conditions while inducing disturbances that are typical of those encountered during data transmission on public service telephone lines. Test data was taken using an AEA Electronics' "Autotest I" modem test set and line simulator, operating under computer control. All tests were run full-duplex, using a Hayes 2400 Smartmodem™ as the reference modem. A 511 pseudo-random-bit pattern was used for each data point. Noise was C-message weighted and all signal-to-noise (S/N) ratios reflect total power measurements similar to the CCITT V.56 measurement specification. The individual tests are defined as follows.

BER vs. S/N

This test measures the ability of the modem to operate over noisy lines with a minimum of data-transfer errors. Since some noise is generated in the best of dial-up lines, the modem must operate with the lowest S/N ratio possible. Better modem performance is indicated by test curves that are closest to the BER axis. A narrow spread between curves representing the four line parameters indicates minimal variation in performance while operating over a range of aberrant operating conditions. Typically, a modem will exhibit better BER-performance test curves receiving in the low band than in the high band.

BER vs. Receive Level

This test measures the dynamic range of the modem. Because signal levels vary widely over dial-up lines, the widest possible dynamic range is desirable. The minimum Bell specification calls for 36 dB of dynamic range. S/N ratios are held constant at the indicated values while the receive level is lowered from a very high to very low signal levels. The width of the "bowl" of these curves, taken at the BER point, is the measure of dynamic range.

SSI 73K324L

CCITT V.22bis, V.22, V.21, V.23, Bell 212A

Single-Chip Modem

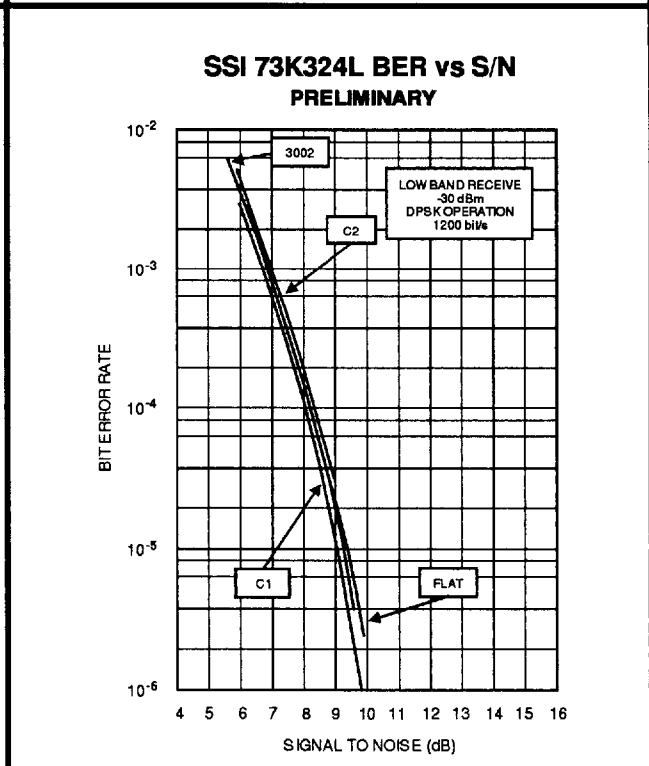
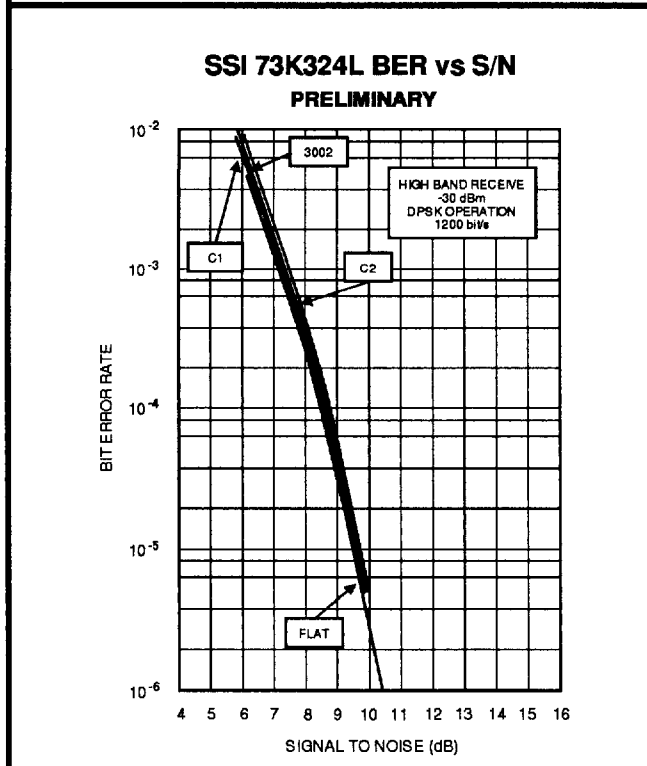
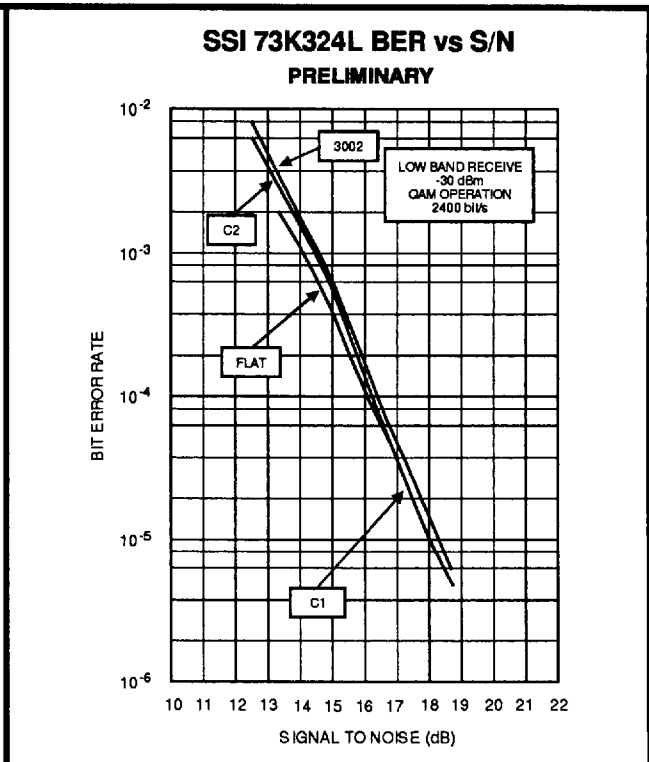
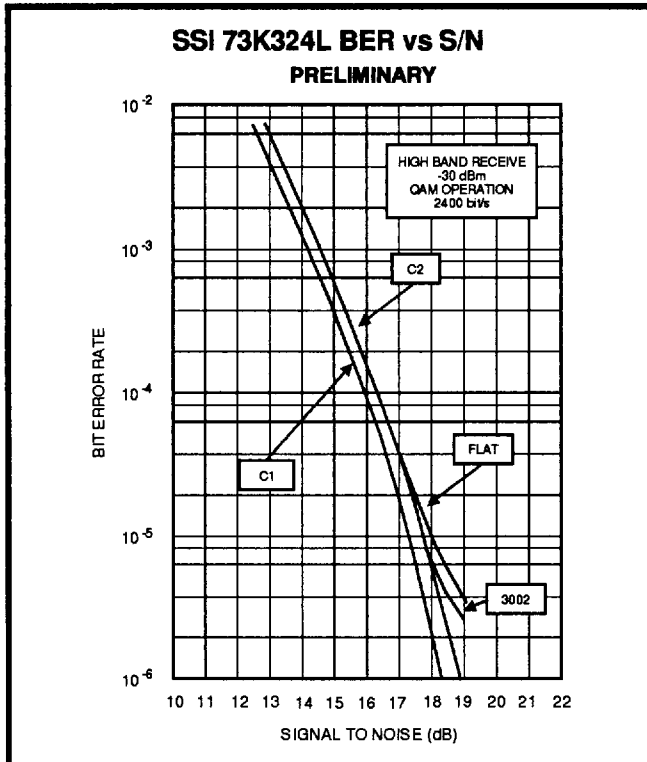

SSI 73K324L CCITT V.22bis, V.22, V.21, V.23, Bell 212A Single-Chip Modem

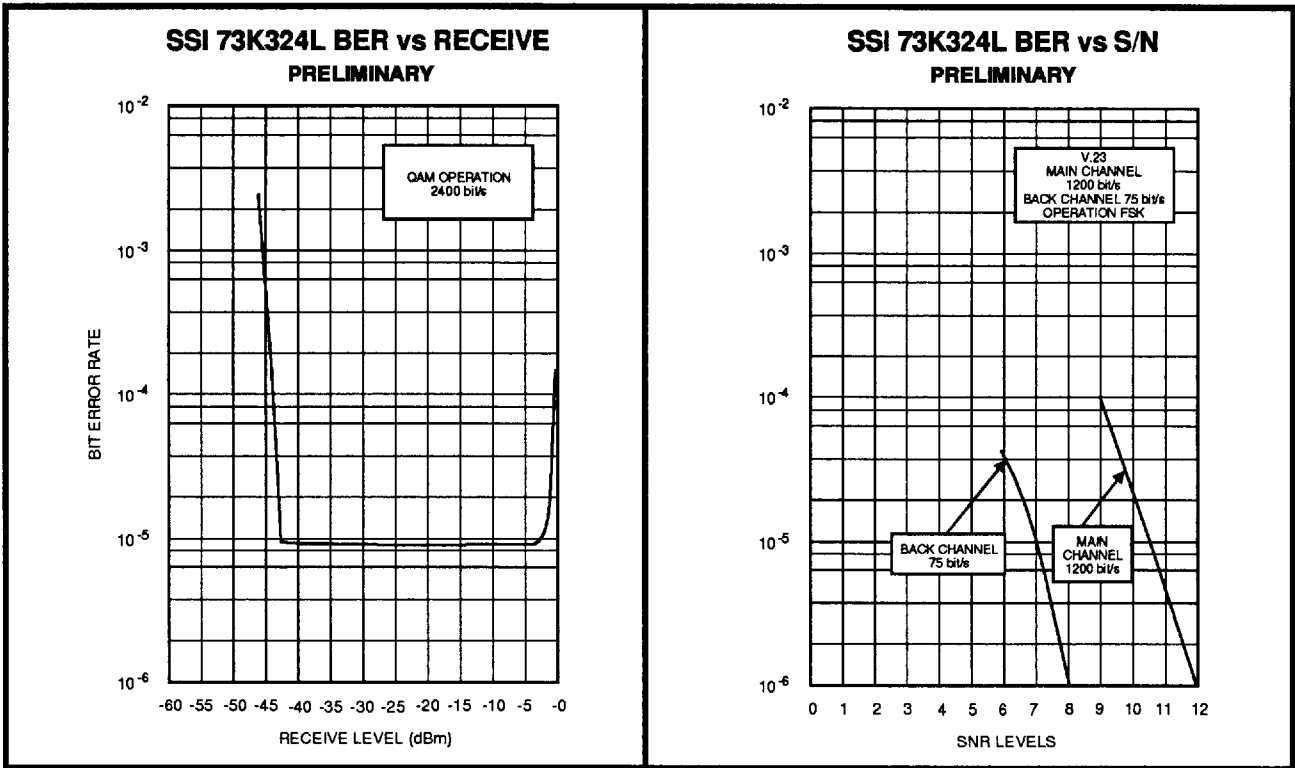

SSI 73K324L

CCITT V.22bis, V.22, V.21, V.23, Bell 212A

Single-Chip Modem

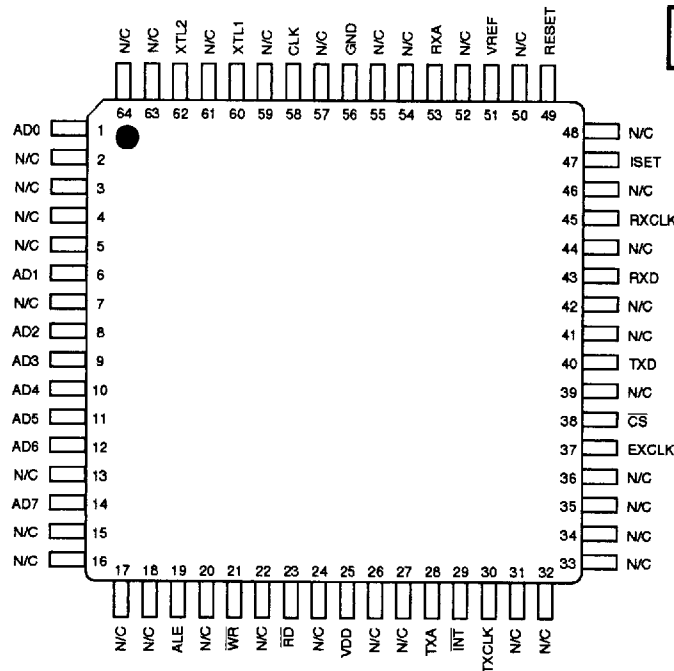

CAUTION: Use handling procedures necessary for a static sensitive component.

64-Lead TQFP

ORDERING INFORMATION

PART DESCRIPTION	ORDER NO.	PKG. MARK
SSI 73K324L		
22-Pin Plastic Dual-In-Line	73K324LS-IP	73K324LS-IP
SSI 73K324L		
28-Pin Plastic Dual-In-Line	73K324L-IP	73K324L-IP
28-Pin Plastic Leaded Chip Carrier	73K324L-28IH	73K324L-28IH
32-Pin Plastic Leaded Chip Carrier	73K324L-32IH	73K324L-32IH
44-Pin Plastic Leaded Chip Carrier	73K324L-IH	73K324L-IH
52-Pin Quad Flat Pack Package	73K324L-IG	73K324L-IG
64-Lead Thin Quad Flat Pack Package	73K324L-IGT	73K324L-IGT

No responsibility is assumed by Silicon Systems for use of this product nor for any infringements of patents and trademarks or other rights of third parties resulting from its use. No license is granted under any patents, patent rights or trademarks of Silicon Systems. Silicon Systems reserves the right to make changes in specifications at any time without notice. Accordingly, the reader is cautioned to verify that the data sheet is current before placing orders.

Silicon Systems, Inc., 14351 Myford Road, Tustin, CA 92680-7022, (714) 573-6000, FAX: (714) 573-6914

Protected by the following patents: (4,777,453)
(4,789,995) (4,870,370) (4,847,868) (4,866,739)