



0.56 Inch (14mm) 4 Digit CLOCK STICK DISPLAY

Plug in replacement for applications using 2 X double digits; where the second display is inserted up-side-down to enable the two assemblies to emulate a clock display - no matching required

AllnGaP Red (630nm) MSQC6H10W
AllnGaP Red (642nm) MSQC6R10W
AllnGaP Yellow MSQC6Y10W

PACKAGE DIMENSIONS	FEATURES
<p>NOTES:</p> <ul style="list-style-type: none"> •Dimensions are in inches (mm) •Tolerances are +/- 0.010 (0.25) unless otherwise stated. 	<ul style="list-style-type: none"> •Bright Bold Segments •Common Anode/Cathode •Low Power Consumption •Low Current Capability •Neutral Segments •Grey Face •Epoxy Encapsulated PCB •High Performance •High Reliability
	APPLICATIONS
	<ul style="list-style-type: none"> •Appliances •Automotive •Instrumentation •Process Control

MODELS AVAILABLE			
Part Number	Colour	Description	Special
MSQC6H10W	AllnGaP 630nm	Clock, RHDP, Common Anode	Low Current Capability
MSQC6H40W	AllnGaP 630nm	Clock, RHDP, Common Cathode	Low Current Capability
MSQC6R10W	AllnGaP 642nm	Clock, RHDP, Common Anode	Low Current Capability
MSQC6R40W	AllnGaP 642nm	Clock, RHDP, Common Cathode	Low Current Capability
MSQC5Y10W	AllnGaP Yellow	Clock, RHDP, Common Anode	Low Current Capability
MSQC6Y40W	AllnGaP Yellow	Clock, RHDP, Common Cathode	Low Current Capability

(For other colour options, contact your local area Sales Manager)



0.56 Inch (14mm) 4 Digit CLOCK STICK DISPLAY

ABSOLUTE MAXIMUM RATINGS⁽¹⁾ ($T_A = 25^\circ\text{C}$, unless otherwise specified)

Part Number	MSQC6H1XW	MSQC6H1XW	MSQC6Y1XW	Units
Parameter				
Continuous Forward Current (each segment)	25	25	25	mA
Peak Forward Current ($F = 10\text{KHz}$, $D/F = 1/10$)	100	100	100	mA
Power Dissipation (P_D)	60	60	60	mW
*Derate Linearly from 25°C	0.36	0.36	0.36	mW
Reverse Voltage per Die				5 Volts
Operating and Storage Temperature Range				-40°C to $+85^\circ\text{C}$
Lead soldering time (1/16 inch from standoffs)				5 seconds @ 230°C

ELECTRO-OPTICAL CHARACTERISTICS⁽¹⁾ ($T_A = 25^\circ\text{C}$, unless otherwise specified)

Part Number	MSQC6H1XW	MSQC6R1XW	MSQC6Y1XW	Units	Test Condition
Parameter					
Luminous intensity⁽²⁾ (I_V)					
Minimum (Standard Current)	6000	4000	8000	ucd	$I_F = 10\text{mA}$
Typical (Standard Current)	7800	5800	12800	ucd	$I_F = 10\text{mA}$
Minimum (Low Current)	510	510	510	ucd	$I_F = 2\text{mA}$
Typical (Low Current)	1000	1000	1000	ucd	$I_F = 2\text{mA}$
Forward Voltage (V_F)					
Typical (Standard Current)	2.05	2.05	2.05	Volts	$I_F = 10\text{mA}$
Maximum (Standard Current)	2.40	2.40	2.40	Volts	$I_F = 10\text{mA}$
Typical (Low Current)	1.80	1.80	1.80	Volts	$I_F = 2\text{mA}$
Maximum (Low Current)	2.20	2.20	2.20	Volts	$I_F = 2\text{mA}$
Peak Wavelength	632	639	591	nm	$I_F = 10\text{mA}$
Dominant Wavelength	624	631	585	nm	$I_F = 10\text{mA}$
Spectral Line 1/2 Width	20	20	20	nm	$I_F = 10\text{mA}$
Reverse B⁽³⁾.Voltage (V_R)	5	5	5	Volts	$I_R = 100\mu\text{A}$

NOTES:

- (1) Data per individual LED element
- (2) Luminous intensity (ucd) = average light output per segment
- (3) B = breakdown

PIN ORIENTATION, SEGMENT IDENTIFICATION, AND PRODUCT MARKING

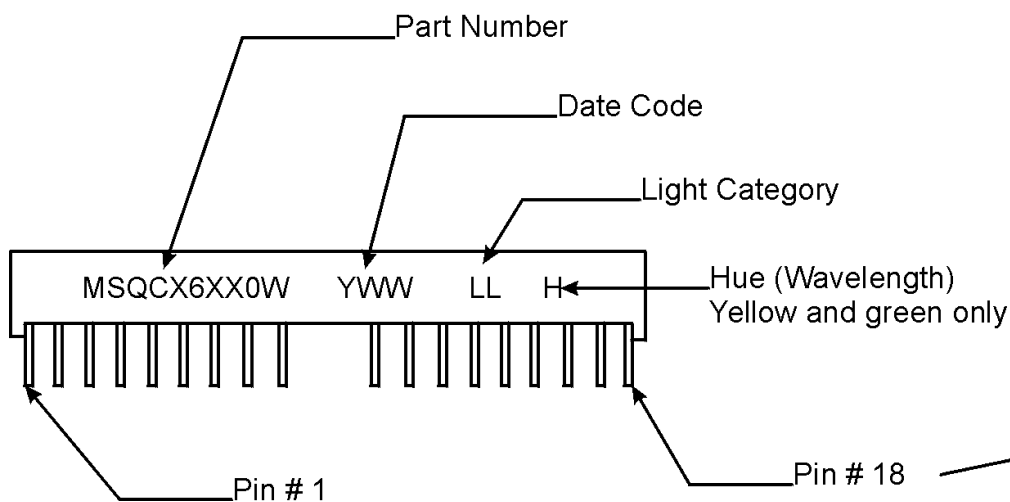
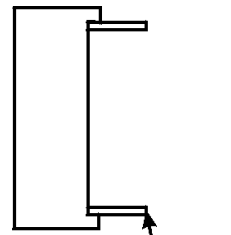
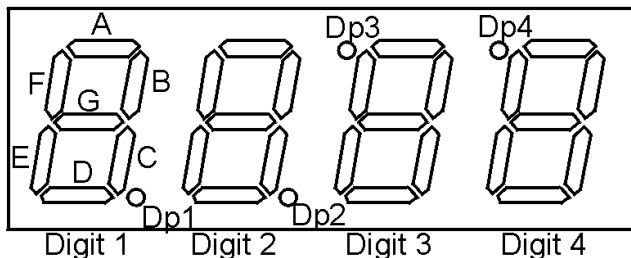

SCHEMATICS

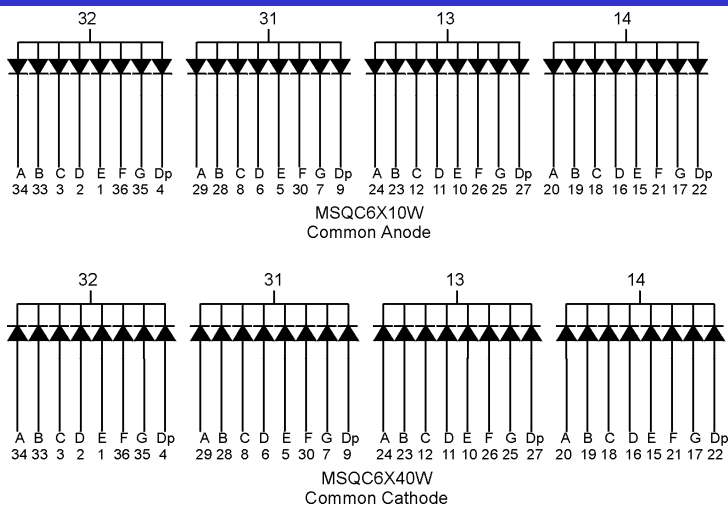

GRAPHICAL DATA AllnGaP 630nm ($T_A = 25^\circ\text{C}$, unless otherwise specified)

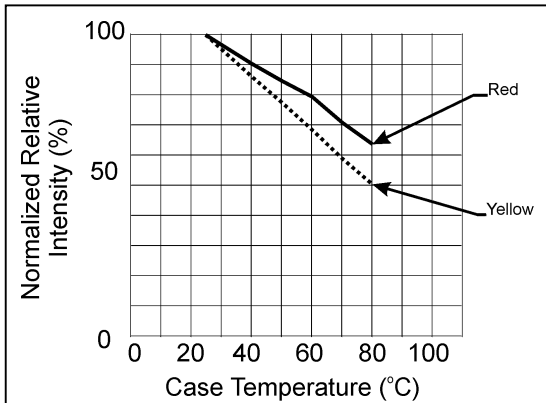

Relative Intensity vs Case Temp.

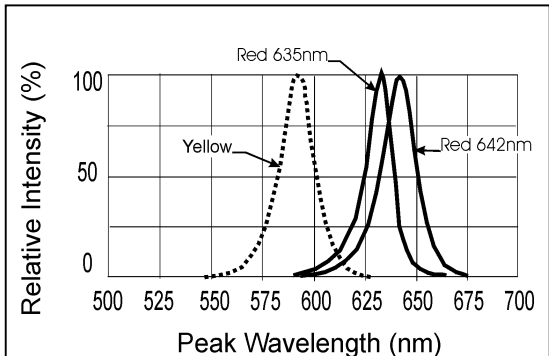

Spectral Response

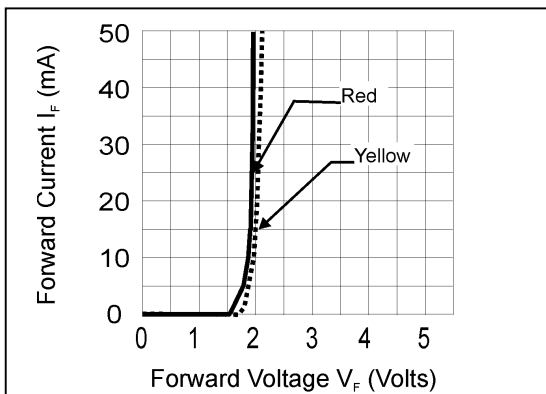

Forward Current vs Forward Voltage

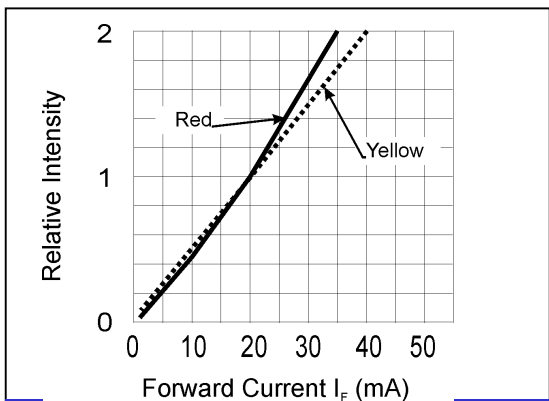

Luminous Intensity vs Duty Cycle

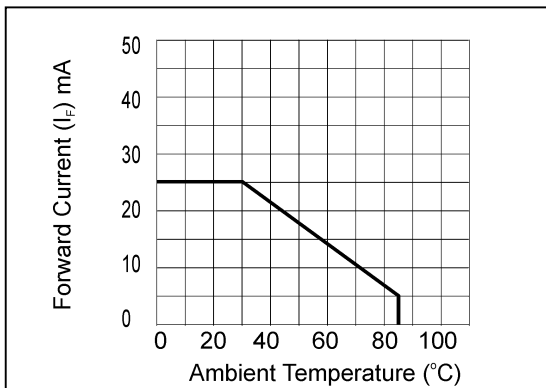

Maximum Forward Current vs Ambient Temperature

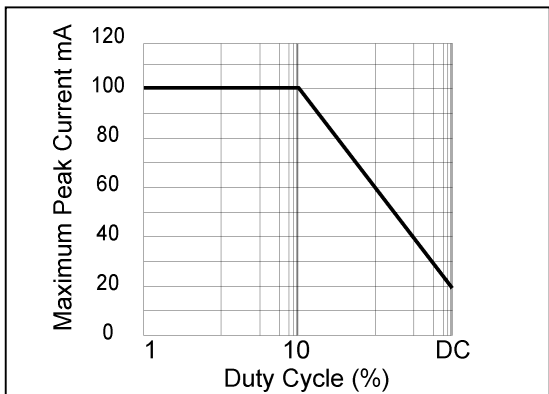

Maximum Peak Current vs Duty Cycle